

Appendix 9A

Stormwater Facility Maintenance Schedules

INSTRUCTIONS FOR USE OF MAINTENANCE CHECKLISTS

The following pages contain maintenance needs for most of the components that are part of your drainage system, as well as for some components that you may not have. Let the county know if there are any components that are missing from these pages. Ignore the requirements that do not apply to your system. You should plan to complete a checklist for all system components on the following schedule:

- (M) Monthly from October through April.
- (A) Once in late summer (preferably September)
- (S) After any major storm (use 1 inch in 24 hours as a guideline).

Use photocopies of these pages and check off the problems you looked for each time you did an inspection. Add comments on problems found and actions taken. Keep these "checked" sheets in your files, as they will be your proof of completing the required inspections and maintenance. Some items do not need to be looked at every time an inspection is done. Use the suggested frequency at the left of each item as a guideline for your inspection.

The facility-specific maintenance standards contained in this section are intended to be conditions for determining if maintenance actions are required as identified through inspection. They are not intended to be measures of the facility's required condition at all times between inspections. In other words, exceedance of these conditions at any time between inspections and/or maintenance does not automatically constitute a violation of these standards. However, based upon inspection observations, the inspection and maintenance schedules shall be adjusted to minimize the length of time that a facility is in a condition that requires a maintenance action.

#1 – Maintenance Checklist for Detention Ponds

Frequency	Drainage System Feature	Date				Problem	Conditions to Check For	Maintenance Activities and Conditions That Should Exist
		✓	✓	✓	✓			
M,S	General					Trash and Debris	Any trash and debris which exceed 5 cubic feet per 1,000 square feet (this is about equal to the amount of trash it would take to fill up one 32 gallon garbage can). In general, there should be no visual evidence of dumping. If less than threshold all trash and debris will be removed as part of next scheduled maintenance.	Trash and debris cleared from site.
A	General					Poisonous Vegetation and noxious weeds	Any poisonous or nuisance vegetation which may constitute a hazard to maintenance personnel or the public. Any evidence of noxious weeds as defined in the Kitsap County Noxious Weeds List. (Apply requirements of adopted integrated pest management policies for the use of herbicides.)	No danger of poisonous vegetation where maintenance personnel or the public might normally be. Complete eradication of noxious weeds may not be possible. Compliance with state or local eradication policies required
M,S	General					Contaminants and Pollution	Any evidence of oil, gasoline, contaminants or other pollutants	No contaminants or pollutants present. (Coordinate removal/cleanup with Department of Ecology Spill Response 800-424-8802.)
M	General					Rodent Holes	If the facility is constructed with a dam or berm, look for rodent holes or any evidence of water piping through the dam or berm.	Rodents removed and dam or berm repaired. (Coordinate h Ecology Dam Safety Office if pond exceeds 10 acre-feet.)
M	General					Beaver Dams	Beaver dam results in an adverse change in the functioning of the facility.	Facility is returned to design function. (Contact WDFW Region 6 to identify the appropriate Nuisance Wildlife Control Operator)
A	General					Insects	When insects such as wasps and hornets interfere with maintenance activities.	Insects destroyed or removed from site. Apply insecticides in compliance with adopted integrated pest management policies.
A	General					Tree Growth and Dense Vegetation	Tree growth and dense vegetation which impedes inspection, maintenance access or interferes with maintenance activity (i.e., slope mowing, silt removal, vactoring, or equipment movements).	Trees and vegetation that does not hinder inspection or maintenance activities. Harvested trees should be recycled into mulch or other beneficial uses (e.g., alders for firewood).

Frequency	Drainage System Feature	Date				Problem	Conditions to Check For	Maintenance Activities and Conditions That Should Exist
		✓	✓	✓	✓			
A	General					Hazard Trees	If dead, diseased, or dying trees are identified (Use a certified Arborist to determine health of tree or removal requirements)	Remove hazard trees
S	General					Performance	Check crest gauge against design expectations (see maintenance plan)	Record reading. Notify county if not meeting design performance.
M, S	Crest Gauge					Crest Gauge Missing/Broken	Crest gage is not functioning properly, has been vandalized, or is missing.	Repair/replace
M	Side Slopes of Pond					Erosion	Erosion damage over 2 inches deep where cause of damage is still present or where there is potential for continued erosion.	Slopes should be stabilized using appropriate erosion control measure(s); e.g., rock reinforcement, planting of grass, compaction.
M, S	Side Slopes of Pond					Erosion	Any erosion observed on a compacted berm embankment.	If erosion is occurring on compacted berms a licensed civil engineer should be consulted to resolve source of erosion.
M	Storage Area					Sediment	Accumulated sediment that exceeds 10 percent of the designed pond depth unless otherwise specified or affects inletting or outletting condition of the facility.	Sediment cleaned out to designed pond shape and depth; pond reseeded if necessary to control erosion. (If sediment contamination is a potential problem, sediment should be tested regularly to determine leaching potential prior to disposal.)
M	Storage Area					Liner (If Applicable)	Liner is visible and has more than three one-fourth inch holes in it.	Liner repaired or replaced. Liner is fully covered.
A	Pond Berms (Dikes)					Settlements	Any part of berm which has settled 4 inches lower than the design elevation. If settlement is apparent, measure berm to determine amount of settlement. Settling can be an indication of more severe problems with the berm or outlet works. A licensed civil engineer should be consulted to determine the source of the settlement.	Dike is built back to the design elevation.
A	Pond Berms Over 4 ft in height (Dikes)					Tree Growth	Tree growth on berms over 4 feet in height may lead to piping through the berm which could lead to failure of the berm	Trees should be removed. If root system is small (base less than 4 inches) the root system may be left in place. Otherwise the roots should be removed and the berm restored. A licensed civil engineer should be consulted for proper berm/spillway restoration.

Frequency	Drainage System Feature	Date				Problem	Conditions to Check For	Maintenance Activities and Conditions That Should Exist
		✓	✓	✓	✓			
A	Pond Berms (Dikes)					Piping	Discernable water flow through pond berm. Ongoing erosion with potential for erosion to continue. (Recommend a Geotechnical engineer be called in to inspect and evaluate condition and recommend repair of condition.)	Piping eliminated. Erosion potential eliminated.
A	Emergency Overflow/ Spillway					Tree Growth	Tree growth on emergency spillways creates blockage problems and may cause failure of the berm due to uncontrolled overtopping.	Trees should be removed. If root system is small (base less than 4 inches) the root system may be left in place. Otherwise the roots should be removed and the berm restored. A licensed civil engineer should be consulted for proper berm/spillway restoration.
A	Emergency Overflow/ Spillway					Rock Missing	Only one layer of rock exists above native soil in area 5 square feet or larger, or any exposure of native soil at the top of out flow path of spillway. (Riprap on inside slopes need not be replaced.)	Rocks and pad depth are restored to design standards.
A	Emergency Overflow/ Spillway					Erosion	Erosion damage over 2 inches deep where cause of damage is still present or where there is potential for continued erosion. Any erosion observed on a compacted berm embankment.	Slopes should be stabilized using appropriate erosion control measure(s); e.g., rock reinforcement, planting of grass, compaction. If erosion is occurring on compacted berms a licensed civil engineer should be consulted to resolve source of erosion.

If you are unsure whether a problem exists, please contact a professional engineer.

Key:

- (M) Monthly from October through April.
- (A) Once in late summer (preferably September)
- (S) After any major storm (use 1 inch in 24 hours as a guideline).

#2 – Maintenance Checklist for Infiltration Facilities

Frequency	Drainage System Feature	Date				Problem	Conditions to Check For	Maintenance Activities and Conditions That Should Exist
		✓	✓	✓	✓			
M,S	General					Trash and Debris	Any trash and debris which exceed 5 cubic feet per 1,000 square feet (this is about equal to the amount of trash it would take to fill up one 32 gallon garbage can). In general, there should be no visual evidence of dumping. If less than threshold all trash and debris will be removed as part of next scheduled maintenance.	Trash and debris cleared from site.
A	General					Poisonous Vegetation and noxious weeds	Any poisonous or nuisance vegetation which may constitute a hazard to maintenance personnel or the public. Any evidence of noxious weeds as defined in the Kitsap County Noxious Weeds List	No danger of poisonous vegetation where maintenance personnel or the public might normally be. Complete eradication of noxious weeds may not be possible. Compliance with state or local eradication policies required
M,S	General					Contaminants and Pollution	Any evidence of oil, gasoline, contaminants or other pollutants	No contaminants or pollutants present. (Coordinate removal/cleanup with Department of Ecology Spill Response 800-424-8802.)
M	General					Rodent Holes	If the facility is constructed with a dam or berm, look for rodent holes or any evidence of water piping through the dam or berm.	Rodents removed and dam or berm repaired. (Coordinate with Ecology Dam Safety Office if pond exceeds 10 acre-feet.)
M	General					Beaver Dams	Beaver dam results in an adverse change in the functioning of the facility.	Facility is returned to design function. (Contact WDFW Region 6 to identify the appropriate Nuisance Wildlife Control Operator)
A	General					Insects	When insects such as wasps and hornets interfere with maintenance activities.	Insects destroyed or removed from site. Apply insecticides in compliance with adopted integrated pest management policies.
S	General					Performance	Check crest gauge against design expectations (see maintenance plan)	Record reading. Notify county if not meeting design performance.
M, S	Crest Gage					Crest Gage Missing/Broken	Crest gage is not functioning properly, has been vandalized, or is missing.	Repair/replace

Frequency	Drainage System Feature	Date				Problem	Conditions to Check For	Maintenance Activities and Conditions That Should Exist
		✓	✓	✓	✓			
M	Storage Area					Water Not Infiltrating	Water ponding in infiltration pond after rainfall ceases and appropriate time allowed for infiltration (24 hours or design infiltration time). (A percolation test pit or test of facility indicates facility is only working at 90 percent of its designed capabilities. If 2 inches or more sediment is present, remove).	Sediment is removed and/or facility is cleaned so that infiltration system works according to design.
M	Filter Bags (if applicable)					Filled with Sediment and Debris	Sediment and debris fill bag more than one-half full.	Filter bag is replaced or system is redesigned.
M,S	Rock Filters					Sediment and Debris	By visual inspection, little or no water flows through filter during heavy rain storms.	Gravel in rock filter is replaced.
A,S	Trenches					Observation Well (Use surface of trench if well is not present)	Water ponds at surface during storm events. Less than 90 percent of design infiltration rate.	Remove and Replace/Clean rock and geomembrane.
M	Ponds					Vegetation	Exceeds 18 inches.	Mow
M	Ponds					Vegetation	Bare spots.	Revegetate and stabilize immediately.
M	Side Slopes of Pond					Erosion	Erosion damage over 2 inches deep where cause of damage is still present or where there is potential for continued erosion.	Slopes should be stabilized using appropriate erosion control measure(s); e.g., rock reinforcement, planting of grass, compaction.
A	Pond Berms (Dikes)					Settlements	Any part of berm which has settled 4 inches lower than the design elevation. If settlement is apparent, measure berm to determine amount of settlement. Settling can be an indication of more severe problems with the berm or outlet works. A licensed civil engineer should be consulted to determine the source of the settlement.	Dike is built back to the design elevation.
A	Pond Berms (Dikes)					Piping	Discernable water flow through pond berm. Ongoing erosion with potential for erosion to continue. (Recommend a Geotechnical engineer be called in to inspect and evaluate condition and recommend repair of condition.	Piping eliminated. Erosion potential eliminated.

Frequency	Drainage System Feature	Date				Problem	Conditions to Check For	Maintenance Activities and Conditions That Should Exist
		✓	✓	✓	✓			
A	General					Hazard Trees	If dead, diseased, or dying trees are identified (Use a certified Arborist to determine health of tree or removal requirements)	Remove hazard trees
A	General					Tree Growth and Dense Vegetation	Tree growth and dense vegetation which impedes inspection, maintenance access or interferes with maintenance activity (i.e., slope mowing, silt removal, vactoring, or equipment movements).	Trees and vegetation that does not hinder inspection or maintenance activities. Harvested trees should be recycled into mulch or other beneficial uses (e.g., alders for firewood).
A	Pond Berms (Dikes)					Tree Growth	Tree growth on berms over 4 feet in height may lead to piping through the berm which could lead to failure of the berm.	Trees should be removed. If root system is small (base less than 4 inches) the root system may be left in place. Otherwise the roots should be removed and the berm restored. A licensed civil engineer should be consulted for proper berm/spillway restoration.
A	Emergency Overflow/ Spillway					Tree Growth	Tree growth on emergency spillways creates blockage problems and may cause failure of the berm due to uncontrolled overtopping.	Trees should be removed. If root system is small (base less than 4 inches) the root system may be left in place. Otherwise the roots should be removed and the berm restored. A licensed civil engineer should be consulted for proper berm/spillway restoration.
A	Emergency Overflow/ Spillway					Rock Missing	Only one layer of rock exists above native soil in area 5 square feet or larger, or any exposure of native soil at the top of out flow path of spillway. (Riprap on inside slopes need not be replaced.)	Rocks and pad depth are restored to design standards.
A	Emergency Overflow/ Spillway					Erosion	Erosion damage over 2 inches deep where cause of damage is still present or where there is potential for continued erosion. Any erosion observed on a compacted berm embankment.	Slopes should be stabilized using appropriate erosion control measure(s); e.g., rock reinforcement, planting of grass, compaction. If erosion is occurring on compacted berms a licensed civil engineer should be consulted to resolve source of erosion.
M	Presettling Ponds and Vaults					Facility or sump filled with Sediment and/or debris	6 inches or designed sediment trap depth of sediment.	Sediment is removed.

If you are unsure whether a problem exists, please contact a professional engineer.

Key:

- (M) Monthly from October through April.
- (A) Once in late summer (preferably September)
- (S) After any major storm (use 1 inch in 24 hours as a guideline).

#3 – Maintenance Checklist for Closed Detention Systems (Tanks/Vaults)

Frequency	Drainage System Feature	Date				Problem	Conditions to Check For	Maintenance Activities and Conditions That Should Exist
		✓	✓	✓	✓			
M	Storage Area					Plugged Air Vents	One-half of the cross-section of a vent is blocked at any point or the vent is damaged.	Vents open and functioning.
M	Storage Area					Debris and Sediment	Accumulated sediment depth exceeds 10 percent of the diameter of the storage area for one-half length of storage vault or any point depth exceeds 15 percent of diameter. (Example: 72-inch storage tank would require cleaning when sediment reaches depth of 7 inches for more than one-half length of tank.)	All sediment and debris removed from storage area.
A	Storage Area					Joints Between Tank/Pipe Section	Any openings or voids allowing material to be transported into facility. (Will require engineering analysis to determine structural stability.)	All joint between tank/pipe sections are sealed.
A	Storage Area					Tank Pipe Bent Out of Shape	Any part of tank/pipe is bent out of shape more than 10 percent of its design shape. (Review required by engineer to determine structural stability.)	Tank/pipe repaired or replaced to design.
A	Storage Area					Vault Structure Includes Cracks in Wall, Bottom, Damage to Frame and/or Top Slab	Cracks wider than one-half inch and any evidence of soil particles entering the structure through the cracks, or maintenance/inspection personnel determines that the vault is not structurally sound.	Vault replaced or repaired to design specifications and is structurally sound.
A	Storage Area					Vault Structure Includes Cracks in Wall, Bottom, Damage to Frame and/or Top Slab	Cracks wider than one-half inch at the joint of any inlet/outlet pipe or any evidence of soil particles entering the vault through the walls	No cracks more than one-fourth inch wide at the joint of the inlet/outlet pipe.
M, S	Crest Gage					Crest Gage Missing/Broken	Crest gage is not functioning properly, has been vandalized, or is missing.	Repair/replace
A	Manhole					Cover Not in Place	Cover is missing or only partially in place. Any open manhole requires maintenance.	Manhole is closed.

Frequency	Drainage System Feature	Date				Problem	Conditions to Check For	Maintenance Activities and Conditions That Should Exist
		✓	✓	✓	✓			
A	Manhole					Locking Mechanism Not Working	Mechanism cannot be opened by one maintenance person with proper tools. Bolts into frame have less than one-half inch of thread (may not apply to self-locking lids).	Mechanism opens with proper tools.
A	Manhole					Cover Difficult to Remove	One maintenance person cannot remove lid after applying normal lifting pressure. Intent is to keep cover from sealing off access to maintenance.	Cover can be removed and reinstalled by one maintenance person.
A	Manhole					Ladder Rungs Unsafe	Ladder is unsafe due to missing rungs, misalignment, not securely attached to structure wall, rust, or cracks.	Ladder meets design standards. Allows maintenance person safe access.

If you are unsure whether a problem exists, please contact a professional engineer.

Tanks and vaults are a confined space. Visual inspections should be performed aboveground. If entry is required it should be performed by qualified personnel.

Key:

- (M) Monthly from October through April.
- (A) Once in late summer (preferably September).
- (S) After any major storm (use 1 inch in 24 hours as a guideline).

Typical Detention Tank

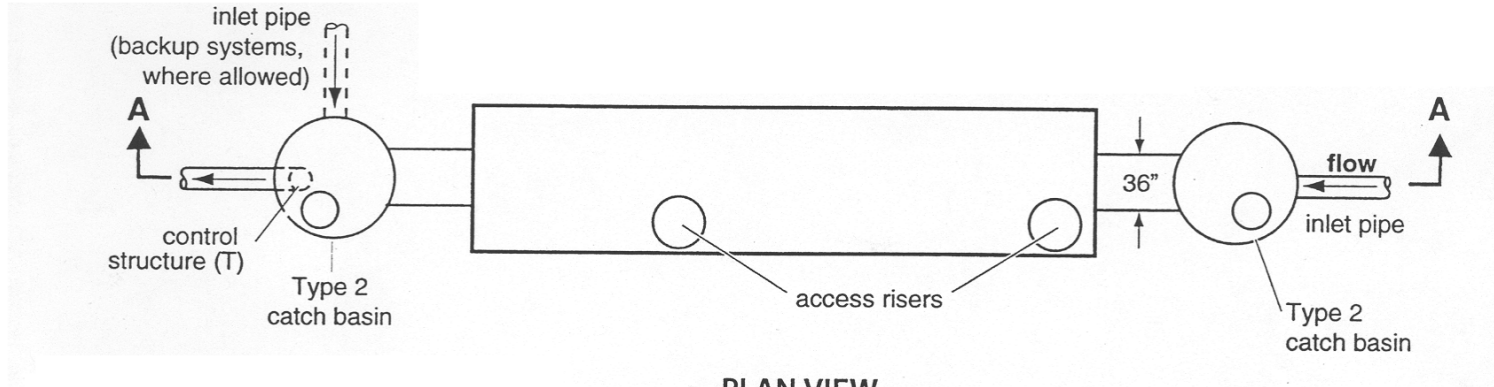

PLAN VIEW
not to scale

“Flow through” system shown solid.
Designs for “flow backup” system and
parallel tanks shown dashed

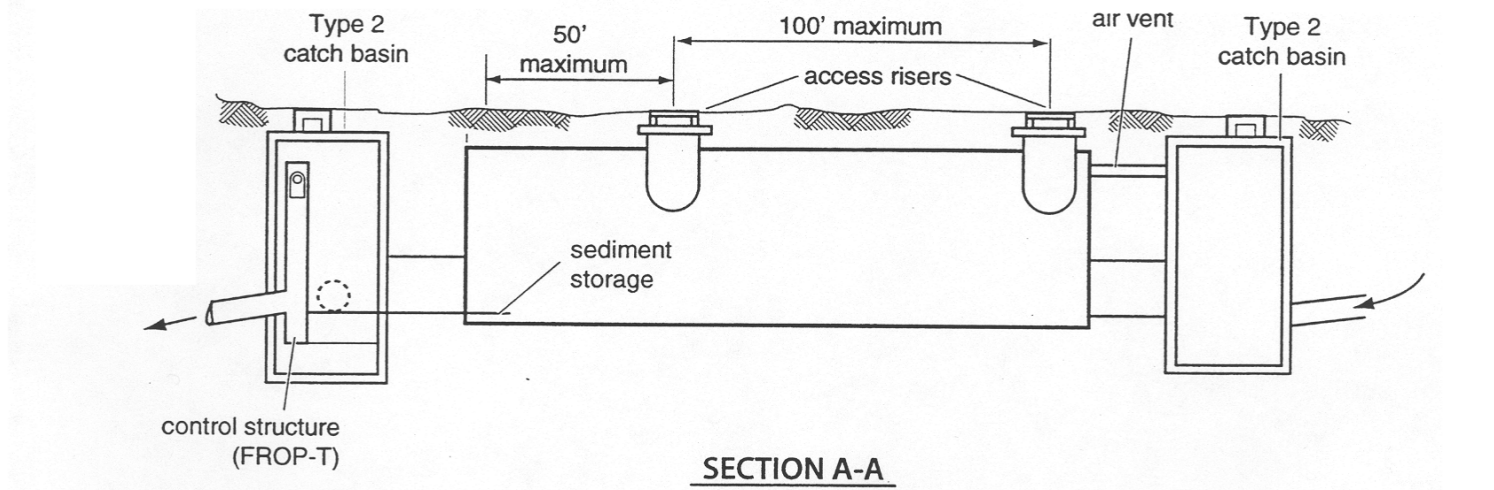

SECTION A-A
not to scale

“Flow through” system shown solid.

#4 – Maintenance Checklist for Control Structure/Flow Restrictor

Frequency	Drainage System Feature	Date				Problem	Conditions to Check For	Maintenance Activities and Conditions That Should Exist
		✓	✓	✓	✓			
M	General					Trash and Debris (Includes Sediment)	Material exceeds 25 percent of sump depth or 1 foot below orifice plate.	Control structure orifice is not blocked. All trash and debris removed.
A	General					Structural Damage	Structure is not securely attached to manhole wall.	Structure securely attached to wall and outlet pipe.
A	General					Structural Damage	Structure is not in upright position (allow up to 10 percent from plumb).	Structure in correct position.
A	General					Structural Damage	Connections to outlet pipe are not watertight and show signs of rust.	Connections to outlet pipe are water tight; structure repaired or replaced and works as designed.
A	General					Structural Damage	Any holes—other than designed holes—in the structure.	Structure has no holes other than designed holes.
A	Cleanout Gate					Damaged or Missing	Cleanout gate is not watertight or is missing.	Gate is watertight and works as designed.
A	Cleanout Gate					Damaged or Missing	Gate cannot be moved up and down by one maintenance person.	Gate moves up and down easily and is watertight.
A	Cleanout Gate					Damaged or Missing	Chain/rod leading to gate is missing or damaged.	Chain is in place and works as designed.
A	Cleanout Gate					Damaged or Missing	Gate is rusted over 50 percent of its surface area.	Gate is repaired or replaced to meet design standards.
A	Orifice Plate					Damaged or Missing	Control device is not working properly due to missing, out of place, or bent orifice plate.	Plate is in place and works as designed.
M,S	Orifice Plate					Obstructions	Any trash, debris, sediment, or vegetation blocking the plate.	Plate is free of all obstructions and works as designed.
M,S	Overflow Pipe					Obstructions	Any trash or debris blocking (or having the potential of blocking) the overflow pipe.	Pipe is free of all obstructions and works as designed.
A	Manhole					Cover Not in Place	Cover is missing or only partially in place. Any open manhole requires maintenance.	Manhole is closed.

Frequency	Drainage System Feature	Date				Problem	Conditions to Check For	Maintenance Activities and Conditions That Should Exist
		✓	✓	✓	✓			
A	Manhole					Locking Mechanism Not Working	Mechanism cannot be opened by one maintenance person with proper tools. Bolts into frame have less than one-half inch of thread (may not apply to self-locking lids).	Mechanism opens with proper tools.
A	Manhole					Cover Difficult to Remove	One maintenance person cannot remove lid after applying normal lifting pressure. Intent is to keep cover from sealing off access to maintenance.	Cover can be removed and reinstalled by one maintenance person.
A	Manhole					Ladder Rungs Unsafe	Ladder is unsafe due to missing rungs, misalignment, not securely attached to structure wall, rust, or cracks.	Ladder meets design standards. Allows maintenance person safe access.

If you are unsure whether a problem exists, please contact a professional engineer.

Control structures are usually considered a confined space. Visual inspections should be performed aboveground. If entry is required it should be performed by qualified personnel.

Key:

- (M) Monthly from October through April.
- (A) Once in late summer (preferably September)
- (S) After any major storm (use 1 inch in 24 hours as a guideline).

Flow Restrictor (T-Section)

(Found in Type 2 Catch Basins)

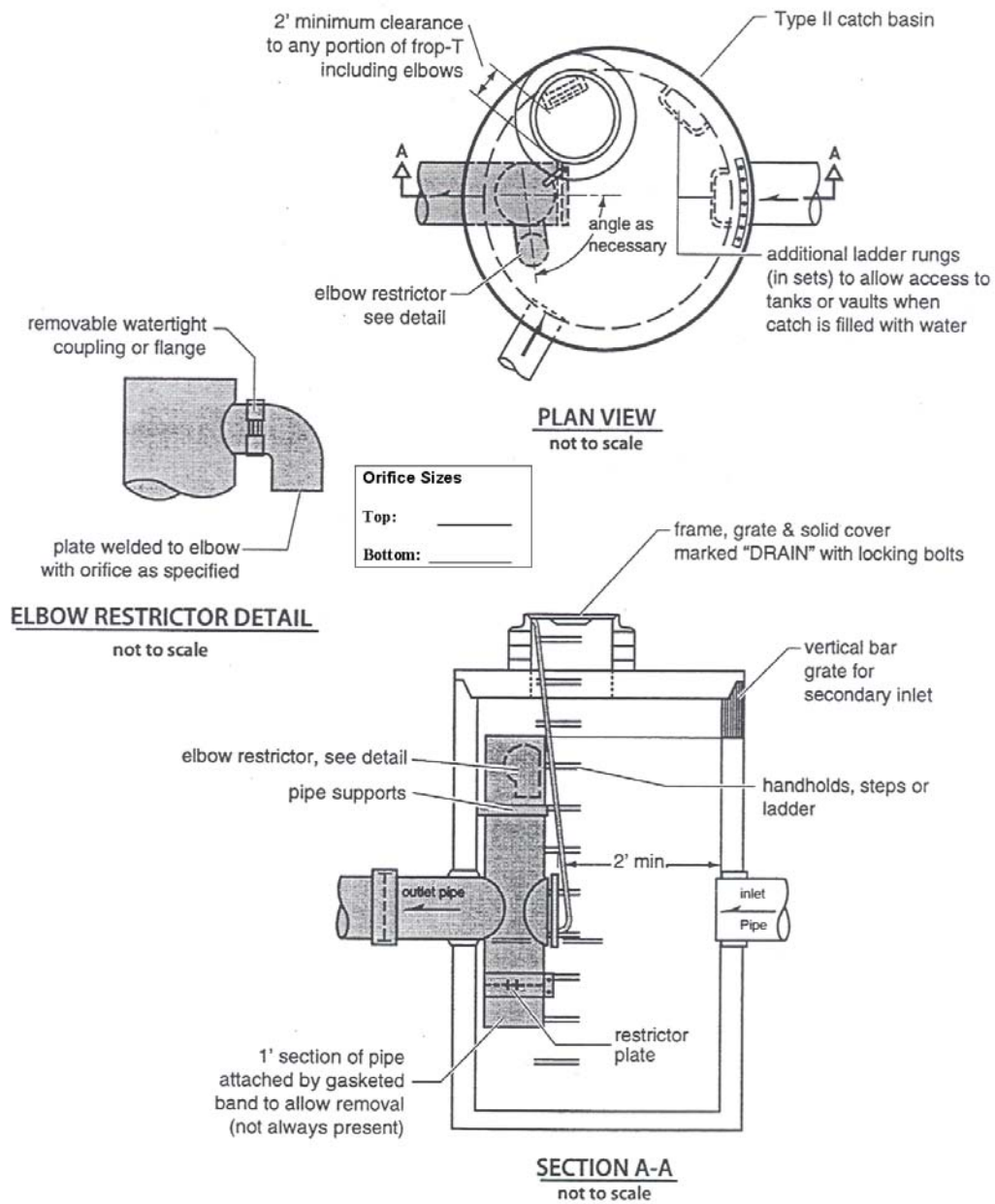

#5 – Maintenance Checklist for Catch Basins

Frequency	Drainage System Feature	Date				Problem	Conditions to Check For	Maintenance Activities and Conditions That Should Exist
		✓	✓	✓	✓			
A	General					"Dump no pollutants" Stencil or stamp not visible	Stencil or stamp should be visible and easily read	Warning signs (e.g., "Dump No Waste-Drains to Stream") shall be painted or embossed on or adjacent to all storm drain inlets.
M,S	General					Trash and Debris	Trash or debris which is located immediately in front of the catch basin opening or is blocking inletting capacity of the basin by more than 10 percent.	No trash or debris located immediately in front of catch basin or on grate opening.
M	General					Trash and Debris	Trash or debris (in the basin) that exceeds 60 percent of the sump depth as measured from the bottom of basin to invert of the lowest pipe into or out of the basin, but in no case less than a minimum of 6 inches clearance from the debris surface to the invert of the lowest pipe.	No trash or debris in the catch basin.
M	General					Trash and Debris	Trash or debris in any inlet or outlet pipe blocking more than one-third of its height.	Inlet and outlet pipes free of trash or debris.
M	General					Trash and Debris	Dead animals or vegetation that could generate odors that could cause complaints or dangerous gases (e.g., methane).	No dead animals or vegetation present within the catch basin.
M	General					Sediment	Sediment (in the basin) that exceeds 60 percent of the sump depth as measured from the bottom of basin to invert of the lowest pipe into or out of the basin, but in no case less than a minimum of 6 inches clearance from the sediment surface to the invert of the lowest pipe.	No sediment in the catch basin
A	General					Structure Damage to Frame and/or Top Slab	Top slab has holes larger than 2 square inches or cracks wider than one-fourth inch (intent is to make sure no material is running into basin).	Top slab is free of holes and cracks.
A	General					Structure Damage to Frame and/or Top Slab	Frame not sitting flush on top slab, i.e., separation of more than three-fourth inch of the frame from the top slab. Frame not securely attached.	Frame is sitting flush on the riser rings or top slab and firmly attached.

Frequency	Drainage System Feature	Date				Problem	Conditions to Check For	Maintenance Activities and Conditions That Should Exist
		✓	✓	✓	✓			
A	General					Fractures or Cracks in Basin Walls/ Bottom	Maintenance person judges that structure is unsound.	Basin replaced or repaired to design standards.
A	General					Fractures or Cracks in Basin Walls/ Bottom	Grout fillet has separated or cracked wider than one-half-inch and longer than 1 foot at the joint of any inlet/outlet pipe or any evidence of soil particles entering catch basin through cracks.	Pipe is regouted and secure at basin wall.
A	General					Settlement/ Misalignment	If failure of basin has created a safety, function, or design problem.	Basin replaced or repaired to design standards.
M	General					Vegetation	Vegetation growing across and blocking more than 10 percent of the basin opening.	No vegetation blocking opening to basin.
M	General					Vegetation	Vegetation growing in inlet/outlet pipe joints that is more than 6 inches tall and less than 6 inches apart.	No vegetation or root growth present.
M	General					Contamination and Pollution	Any evidence of oil, gasoline, contaminants or other pollutants.	No contaminants or pollutants present. (Coordinate removal/cleanup with Department of Ecology Spill Response 800-424-8802.)
A	Catch Basin Cover					Cover Not in Place	Cover is missing or only partially in place.	Any open catch basin requires maintenance. Catch basin cover is closed
A	Catch Basin Cover					Locking Mechanism Not Working	Mechanism cannot be opened by one maintenance person with proper tools. Bolts into frame have less than one-half-inch of thread.	Mechanism opens with proper tools.
A	Catch Basin Cover					Cover Difficult to Remove	One maintenance person cannot remove lid after applying normal lifting pressure. (Intent is keep cover from sealing off access to maintenance.)	Cover can be removed by one maintenance person.
A	Ladder					Ladder Rungs Unsafe	Ladder is unsafe due to missing rungs, not securely attached to basin wall, misalignment, rust, cracks, or sharp edges.	Ladder meets design standards and allows maintenance person safe access.
	Grates					Grate opening Unsafe	Grate with opening wider than seven-eighths of an inch.	Grate opening meets design standards.

Frequency	Drainage System Feature	Date				Problem	Conditions to Check For	Maintenance Activities and Conditions That Should Exist
		✓	✓	✓	✓			
M,S	Grates					Trash and Debris	Trash and debris that is blocking more than 20 percent of grate surface inletting capacity.	Grate free of trash and debris.
A	Grates					Damaged or Missing.	Grate missing or broken member(s) of the grate.	Grate is in place and meets design standards.

If you are unsure whether a problem exists, please contact a professional engineer.

Key:

- (M) Monthly from October through April.
- (A) Once in late summer (preferably September)
- (S) After any major storm (use 1 inch in 24 hours as a guideline).

Type I Catch Basin

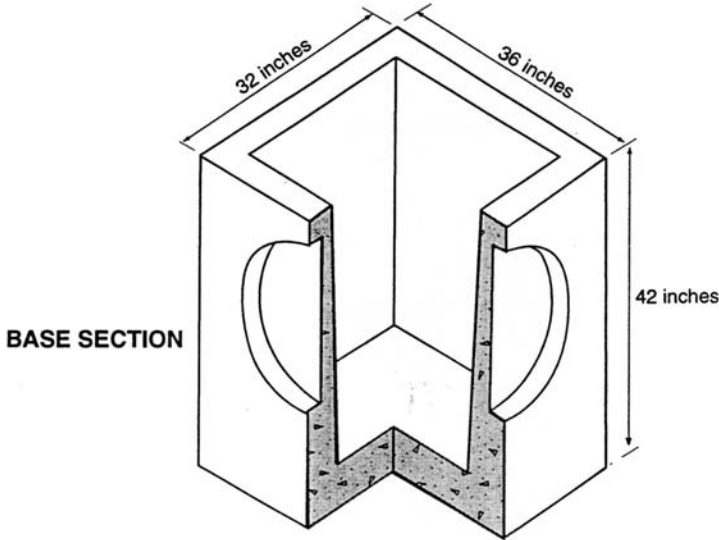
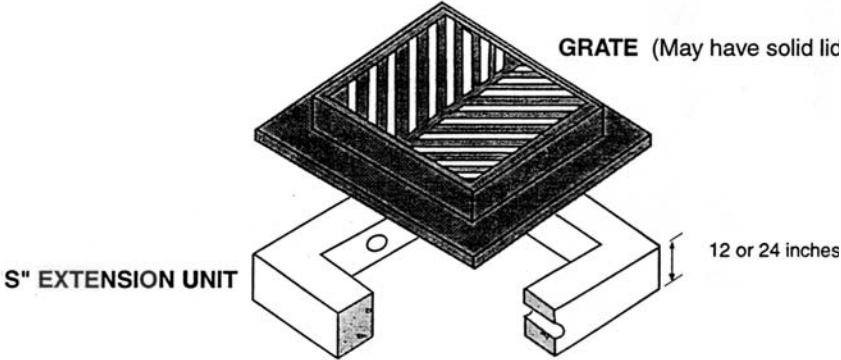

Type II Catch Basin (Round concrete structure)

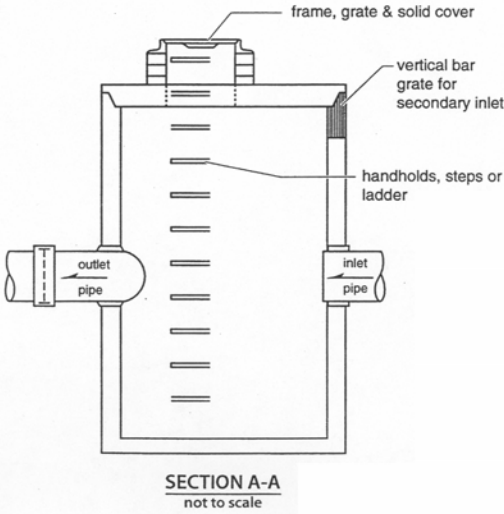
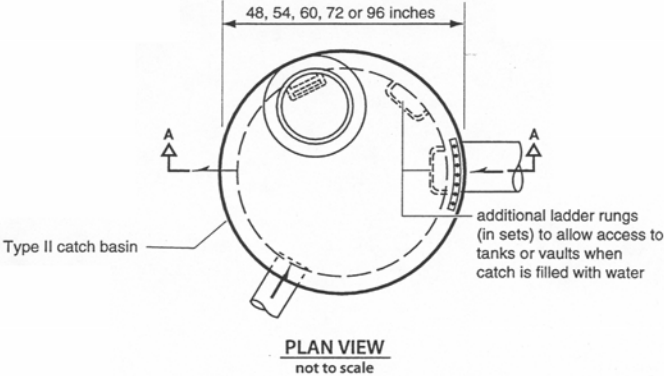

#6 – Maintenance Checklist for Debris Barriers (e.g., Trash Racks)

Frequency	Drainage System Feature	Date				Problem	Conditions to Check For	Maintenance Activities and Conditions That Should Exist
		✓	✓	✓	✓			
M, S	General					Trash and Debris	Trash or debris that is plugging more than 20 percent of the openings in the barrier.	Barrier cleared to design flow capacity.
A	General					Damaged/Missing Bars.	Bars are bent out of shape more than 3 inches.	Bars in place with no bends more than three-fourth inch.
A	General					Damaged/Missing Bars.	Bars are missing or entire barrier missing.	Bars in place according to design.
A	General					Damaged/Missing Bars.	Bars are loose and rust is causing 50 percent deterioration to any part of barrier.	Barrier replaced or repaired to design standards.
A	General					Inlet/Outlet Pipe	Debris barrier missing or not attached to pipe.	Barrier firmly attached to pipe.

If you are unsure whether a problem exists, please contact a professional engineer.

Key:

- (M) Monthly from October through April.
- (A) Once in late summer (preferably September)
- (S) After any major storm (use 1 inch in 24 hours as a guideline).

#7 – Maintenance Checklist for Energy Dissipaters

Frequency	Drainage System Feature	Date				Problem	Conditions to Check For	Maintenance Activities and Conditions That Should Exist
		✓	✓	✓	✓			
External:								
M	Rock Pad					Missing or Moved Rock	Only one layer of rock exists above native soil in area 5 square feet or larger, or any exposure of native soil.	Rock pad replaced to design standards.
M	Rock Pad					Erosion	Soil erosion in or adjacent to rock pad.	Rock pad replaced to design standards.
M	Dispersion Trench					Pipe Plugged with Sediment	Accumulated sediment that exceeds 20 percent of the design depth.	Pipe cleaned/flushed so that it matches design.
M	Dispersion Trench					Not Discharging Water Properly	Visual evidence of water discharging at concentrated points along trench (normal condition is a "sheet flow" of water along trench). Intent is to prevent erosion damage.	Trench redesigned or rebuilt to standards.
M	Dispersion Trench					Perforations Plugged	Over one-half of perforations in pipe are plugged with debris and sediment.	Perforated pipe cleaned or replaced.
M	Dispersion Trench					Water Flows Out Top of "Distributor" Catch Basin.	Maintenance person observes or receives credible report of water flowing out during any storm less than the design storm or its causing or appears likely to cause damage.	Facility rebuilt or redesigned to standards.
M	Dispersion Trench					Receiving Area Over-Saturated	Water in receiving area is causing or has potential of causing landslide problems.	No danger of landslides.
Internal:								
M	Manhole/ Chamber					Worn or Damaged Post, Baffles, Side of Chamber	Structure dissipating flow deteriorates to one-half of original size or any concentrated worn spot exceeding 1 square foot which would make structure unsound	Structure replaced to design standards.

Frequency	Drainage System Feature	Date				Problem	Conditions to Check For	Maintenance Activities and Conditions That Should Exist
		✓	✓	✓	✓			
M	Manhole/ Chamber					Trash and Debris	Trash or debris (in the basin) that exceeds 60 percent of the sump depth as measured from the bottom of basin to invert of the lowest pipe into or out of the basin, but in no case less than a minimum of 6 inches clearance from the debris surface to the invert of the lowest pipe.	No trash or debris in the catch basin.
M	Manhole/ Chamber					Trash and Debris	Trash or debris in any inlet or outlet pipe blocking more than one-third of its height.	Inlet and outlet pipes free of trash or debris.
M	Manhole/ Chamber					Trash and Debris	Dead animals or vegetation that could generate odors that could cause complaints or dangerous gases (e.g., methane).	No dead animals or vegetation present within the catch basin.
M	Manhole/ Chamber					Sediment	Sediment (in the basin) that exceeds 60 percent of the sump depth as measured from the bottom of basin to invert of the lowest pipe into or out of the basin, but in no case less than a minimum of 6 inches clearance from the sediment surface to the invert of the lowest pipe.	No sediment in the catch basin.
A	Manhole/ Chamber					Structure Damage to Frame and/or Top Slab	Top slab has holes larger than 2 square inches or cracks wider than one-fourth inch (intent is to make sure no material is running into basin).	Top slab is free of holes and cracks.
A	Manhole/ Chamber					Structure Damage to Frame and/or Top Slab	Frame not sitting flush on top slab, i.e., separation of more than three-fourth inch of the frame from the top slab. Frame not securely attached	Frame is sitting flush on the riser rings or top slab and firmly attached.
A	Manhole/ Chamber					Fractures or Cracks in Basin Walls/ Bottom	Maintenance person judges that structure is unsound.	Basin replaced or repaired to design standards.
A	Manhole/ Chamber					Fractures or Cracks in Basin Walls/ Bottom	Grout fillet has separated or cracked wider than one-half-inch and longer than 1 foot at the joint of any inlet/outlet pipe or any evidence of soil particles entering catch basin through cracks.	Pipe is regouted and secure at basin wall.
A	Manhole/ Chamber					Settlement/ Misalignment	If failure of basin has created a safety, function, or design problem.	Basin replaced or repaired to design standards.
M	Manhole/ Chamber					Contamination and Pollution	Any evidence of oil, gasoline, contaminants or other pollutants.	No contaminants or pollutants present. (Coordinate removal/cleanup Department of Ecology Spill Response 800-424-8802.)

Frequency	Drainage System Feature	Date				Problem	Conditions to Check For	Maintenance Activities and Conditions That Should Exist
		✓	✓	✓	✓			
A	Catch Basin Cover					Cover Not in Place	Cover is missing or only partially in place.	Any open catch basin requires maintenance. Catch basin cover is closed.
A	Catch Basin Cover					Locking Mechanism Not Working	Mechanism cannot be opened by one maintenance person with proper tools. Bolts into frame have less than one-half-inch of thread.	Mechanism opens with proper tools.
A	Catch Basin Cover					Cover Difficult to Remove	One maintenance person cannot remove lid after applying normal lifting pressure. (Intent is keep cover from sealing off access to maintenance.)	Cover can be removed by one maintenance person.

If you are unsure whether a problem exists, please contact a professional engineer.

Key:

- (M) Monthly from October through April.
- (A) Once in late summer (preferably September)
- (S) After any major storm (use 1 inch in 24 hours as a guideline).

#8 – Maintenance Checklist for Typical Biofiltration Swale

Frequency	Drainage System Feature	Date				Problem	Conditions to Check For	Maintenance Activities and Conditions That Should Exist
		✓	✓	✓	✓			
M	General					Sediment Accumulation on Grass	Sediment depth exceeds 2 Inches or inhibits vegetation growth in 10 percent or more of swale.	Remove sediment deposits on grass treatment area of the bioswale. When finished, swale should be level from side to side and drain freely toward outlet. There should be no areas of standing water once inflow has ceased.
M	General					Standing Water	When water stands in the swale between storms and does not drain freely.	Any of the following may apply: remove sediment or trash blockages, improve grade from head to foot of swale, remove clogged check dams, add underdrains or convert to a wet biofiltration swale.
M	General					Flow spreader	Flow spreader uneven or clogged so that flows are not uniformly distributed through entire swale width.	Level the spreader and clean so that flows are spread evenly over entire swale width.
M	General					Constant Baseflow	When small quantities of water continually flow through the swale, even when it has been dry for weeks, and an eroded, muddy channel has formed in the swale bottom.	Add a low-flow pea-gravel drain the length of the swale or by-pass the baseflow around the swale.
M	General					Poor Vegetation Coverage	When grass is sparse or bare or eroded patches occur in more than 10 percent of the swale bottom.	Determine why grass growth is poor and correct that condition. Re-plant with plugs of grass from the upper slope: plant in the swale bottom at 8-inch intervals. Or re-seed into loosened, fertile soil.
M	General					Vegetation	When the grass becomes excessively tall (greater than 10 inches); when nuisance weeds and other vegetation starts to take over.	Mow vegetation or remove nuisance vegetation so that flow not impeded. Grass should be mowed to a height of 3 to 4 inches. Remove grass clippings.
M	General					Excessive Shading	Grass growth is poor because sunlight does not reach swale.	If possible, trim back over-hanging limbs and remove brushy vegetation on adjacent slopes.
M	General					Inlet/Outlet	Inlet/outlet areas clogged with sediment and/or debris.	Remove material so that there is no clogging or blockage in the inlet and outlet area.

Frequency	Drainage System Feature	Date				Problem	Conditions to Check For	Maintenance Activities and Conditions That Should Exist
		✓	✓	✓	✓			
M	General					Trash and Debris Accumulation	Trash and debris accumulated in the bioswale.	Remove leaves, litter, and oily materials, and re-seed or resod, and regrade, as needed. Clean curb cuts and level spreaders as needed.
M	General					Erosion/Scouring	Eroded or scoured swale bottom due to flow channelization, or higher flows.	For ruts or bare areas less than 12 inches wide, repair the damaged area by filling with crushed gravel. If bare areas are large, generally greater than 12 inches wide, the swale should be re-graded and re-seeded. For smaller bare areas, overseed when bare spots are evident, or take plugs of grass from the upper slope and plant in the swale bottom at 8-inch intervals.

If you are unsure whether a problem exists, please contact a professional engineer.

Key:

- (M) Monthly from October through April.
- (A) Once in late summer (preferably September)
- (S) After any major storm (use 1 inch in 24 hours as a guideline).

Typical Bioswale

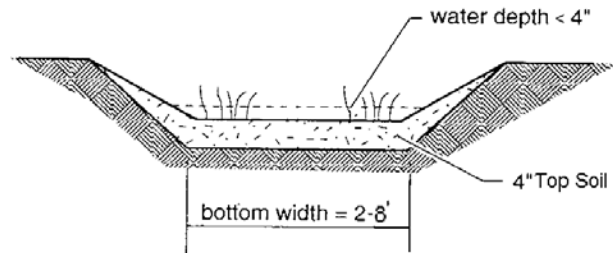

BIOSWALE SECTION
not to scale

Underdrain for Slopes < 1%

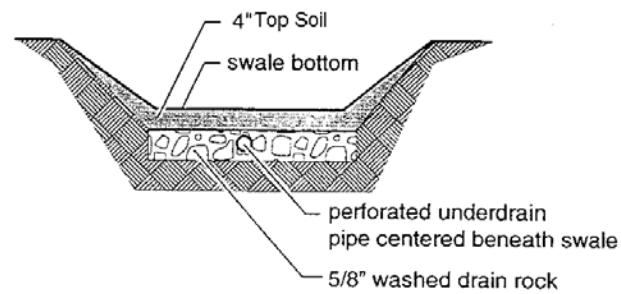

NOTE: Underdrain must infiltrate or drain freely to an acceptable discharge point.

BIOSWALE WITH UNDERDRAIN SECTION
not to scale

#9 – Maintenance Checklist for Wet Biofiltration Swales

Frequency	Drainage System Feature	Date				Problem	Conditions to Check For	Maintenance Activities and Conditions That Should Exist
		✓	✓	✓	✓			
M	General					Sediment Accumulation	Sediment depth exceeds 2 inches in 10 percent of the swale treatment area.	Remove sediment deposits in treatment area.
M	General					Water Depth	Water not retained to a depth of about 4 inches during the wet season.	Build up or repair outlet berm so that water is retained in the wet swale.
M	General					Wetland Vegetation	Vegetation becomes sparse and does not provide adequate filtration, OR vegetation is crowded out by very dense clumps of cattail, which do not allow water to flow through the clumps.	Determine cause of lack of vigor of vegetation and correct. Replant as needed. For excessive cattail growth, cut cattail shoots back and compost offsite. Note: normally wetland vegetation does not need to be harvested unless die-back is causing oxygen depletion in downstream waters.
M	General					Inlet/Outlet	Inlet/outlet area clogged with sediment and/or debris.	Remove clogging or blockage in the inlet and outlet areas.
M	General					Trash and Debris Accumulation	Any trash and debris which exceed 5 cubic feet per 1,000 square feet (this is about equal to the amount of trash it would take to fill up one 32 gallon garbage can). In general, there should be no visual evidence of dumping. If less than threshold all trash and debris will be removed as part of next scheduled maintenance.	Remove trash and debris from wet swale.
M	General					Erosion/Scouring	Swale has eroded or scoured due to flow channelization, or higher flows.	Check design flows to assure swale is large enough to handle flows. By-pass excess flows or enlarge swale. Replant eroded areas with fibrous-rooted plants such as Juncus effusus (soft rush) in wet areas or snowberry (Symphoricarpos albus) in dryer areas.

If you are unsure whether a problem exists, please contact a professional engineer.

Key:

- (M) Monthly from October through April.
- (A) Once in late summer (preferably September)
- (S) After any major storm (use 1 inch in 24 hours as a guideline).

#10 – Maintenance Checklist for Filter Strips

Frequency	Drainage System Feature	Date				Problem	Conditions to Check For	Maintenance Activities and Conditions That Should Exist
		✓	✓	✓	✓			
M	General					Sediment Accumulation on Grass	Sediment depth exceeds 2 inches.	Remove sediment deposits, re-level so slope is even and flows pass evenly through strip.
M	General					Vegetation	When the grass becomes excessively tall (greater than 10 inches); when nuisance weeds and other vegetation starts to take over.	Mow grass, control nuisance vegetation, such that flow not impeded. Grass should be mowed to a height between 3-4 inches.
M	General					Trash and Debris Accumulation	Trash and debris accumulated on the filter strip.	Remove trash and Debris from filter.
M	General					Erosion/Scouring	Eroded or scoured areas due to flow channelization, or higher flows.	For ruts or bare areas less than 12 inches wide, repair the damaged area by filling with crushed gravel. The grass will creep in over the rock in time. If bare areas are large, generally greater than 12 inches wide, the filter strip should be re-graded and re-seeded. For smaller bare areas, overseed when bare spots are evident.
M	General					Flow spreader	Flow spreader uneven or clogged so that flows are not uniformly distributed through entire filter width.	Level the spreader and clean so that flows are spread evenly over entire filter width

If you are unsure whether a problem exists, please contact a professional engineer.

Key:

- (M) Monthly from October through April.
- (A) Once in late summer (preferably September)
- (S) After any major storm (use 1 inch in 24 hours as a guideline).

#11 – Maintenance Checklist for Wet Ponds

Frequency	Drainage System Feature	Date				Problem	Conditions to Check For	Maintenance Activities and Conditions That Should Exist
		✓	✓	✓	✓			
M	General					Water level	First cell is empty, doesn't hold water.	Line the first cell to maintain at least 4 feet of water. Although the second cell may drain, the first cell must remain full to control turbulence of the incoming flow and reduce sediment resuspension.
M						Trash and Debris	Accumulation that exceeds 1 cubic foot per 1000 square feet of pond area.	Trash and debris removed from pond
M						Inlet/Outlet Pipe	Inlet/Outlet pipe clogged with sediment and/or debris material	No clogging or blockage in the inlet and outlet piping.
M						Sediment Accumulation in Pond Bottom	Sediment accumulations in pond bottom that exceeds the depth of sediment zone plus 6 inches, usually in the first cell.	Sediment removed from pond bottom. (If sediment contamination is a potential problem, sediment should be tested regularly to determine leaching potential prior to disposal.)
M						Oil Sheen on Water	Prevalent and visible oil sheen.	Oil removed from water using oil- absorbent pads or vacor truck. Source of oil located and corrected. If chronic low levels of oil persist, plant wetland plants such as Juncus effusus (soft rush) which can uptake small concentrations of oil.
A						Erosion	Erosion of the pond's side slopes and/or scouring of the pond bottom that exceeds 6 inches, or where continued erosion is prevalent.	Slopes stabilized using proper erosion control measures and repair methods.
A						Settlement of Pond Dike/Berm	Any part of these components that has settled 4 inches or lower than the design elevation, or inspector determines dike/berm is unsound.	Dike/berm is repaired to specifications
A						Internal Berm	Berm dividing cells should be level.	Berm surface is leveled so that water flows evenly over entire length of berm.
A						Overflow Spillway	Rock is missing and soil is exposed at top of spillway or outside slope.	Rocks replaced to specifications.

If you are unsure whether a problem exists, please contact a professional engineer.

Key:

- (M) Monthly from October through April.
- (A) Once in late summer (preferably September)
- (S) After any major storm (use 1 inch in 24 hours as a guideline).

#11 – Maintenance Checklist for Treatment Wetlands

Frequency	Drainage System Feature	Date				Problem	Conditions to Check For	Maintenance Activities and Conditions That Should Exist
		✓	✓	✓	✓			
B	General					Trash and Debris	Any trash and debris accumulations which exceed 5 cubic feet per 1,000 square feet (this is a little more than the amount of trash it would take to fill up one standard 32 gallon garbage can). In general, there should be no visual evidence of dumping. If there is less than the threshold, remove all trash and debris as part of the next scheduled maintenance.	Trash and debris cleared from site.
B	General					Poisonous Vegetation and Noxious Weeds	Any poisonous or nuisance vegetation which may constitute a hazard to maintenance personnel or the public. Any evidence of noxious weeds as defined in the Kitsap County Noxious Weeds List.	No danger of poisonous vegetation where maintenance personnel or the public might have contact. (Coordinate with Kitsap County Noxious Weed Coordinator.) Complete eradication of noxious weeds may not be possible, however compliance with state or local eradication policies are required.
B	General					Oil Sheen on Water	Prevalent and visible oil sheen.	Oil removed from water using oil- absorbent pads or vactor truck. Source of oil located and corrected. If chronic low levels of oil persist, plant emergent wetland plants such as Juncus effusus (soft rush) which can assist filtering small concentrations of oil.
B, S	General					Inlet/Outlet Pipe	Inlet/Outlet pipe clogged with sediment and/or debris material or damaged.	No clogging or blockage in the inlet and outlet piping.
B	General					Rodent Holes	If the facility is constructed with a dam or berm, look for rodent holes or any evidence of water piping through the dam or berm.	Rodents removed and dam or berm repaired. (Coordinate with Ecology Dam Safety Office if pond exceeds 10 acre-feet.)
B	General					Beaver Dams	Beaver dam results in an adverse change in the functioning of the facility.	Facility is fully functioning. Evaluate using beaver deceiver and leveler devices. If beaver removal is necessary, contact WDFW Region 6 to coordinate with a Nuisance Wildlife Control Operator.

Frequency	Drainage System Feature	Date				Problem	Conditions to Check For	Maintenance Activities and Conditions That Should Exist
		✓	✓	✓	✓			
B	General					Tree Growth and Hazard Trees	Tree growth that impedes maintenance access.	Trees do not hinder maintenance activities. Harvested trees should be recycled into mulch or other beneficial uses (e.g., firewood or construction).
B	General					Tree Growth and Hazard Trees	If dead, diseased, or dying trees are identified, use a certified Arborist to determine the health of tree and whether removal is required.	Remove hazard trees.
B	General					Liner	Liner is visible and has more than three one-fourth inch holes in it.	Liner is repaired or replaced. Liner is fully covered.
B	Forebay					Sediment Accumulation	Sediment accumulation in forebay exceeds the design depth of the sediment zone plus 6 inches.	Accumulated sediment is removed from forebay bottom to the design depth of the sediment zone.
B	Side Slopes of Wetland					Erosion	Erosion damage over 2 inches deep where cause of damage is still present or where there is potential for continued erosion.	Slopes should be stabilized using appropriate erosion control measure(s) such as rock reinforcement, planting of grass, or additional compaction.
B, S	Side Slopes of Wetland					Erosion	Any erosion observed on a compacted berm embankment.	If erosion is occurring on compacted berms a licensed civil engineer should be consulted to resolve source of erosion.
B	Wetland Cell					Wetland Vegetation	20 percent or more of the constructed wetland area has dead or dying vegetation, as measured by stem counts relative to the design plant coverage.	Dead or dying vegetation is replaced by like species, unless recommended otherwise by the Wetlands Consultant and approved by the county. (Watering, physical support, mulching, and weed removal may be required on a regular basis especially during the first 3 years.)
B	Wetland Cell					Wetland Vegetation	Percent vegetated cover of constructed wetland bottom area, excluding exotic and invasive species, is less than 50 percent after 2 years.	Remove exotic/invasive species provide additional plantings may be required
B	Wetland Cell					Wetland Vegetation	Decaying vegetation produces foul odors.	Decaying vegetation is removed, preferably in late summer.
C	Wetland Cell					Wetland Vegetation	Wetland vegetation is blocking flow paths causing flow back-up and flooding.	Areas of blocking vegetation are cut back sufficient to allow design flows and prevent flooding.

Frequency	Drainage System Feature	Date				Problem	Conditions to Check For	Maintenance Activities and Conditions That Should Exist
		✓	✓	✓	✓			
A	Wetland Cell					Wetland Vegetation	Water quality monitoring indicates that wetland vegetation is contributing phosphorus and metals to downstream waters rather than sequestering them.	To maximize removal of wetland pollutants, wetland vegetation must be periodically harvested, particularly with respect to phosphorus and metals removal. Harvesting should occur by mid-summer before plants begin to transfer phosphorus from the aboveground foliage to subsurface roots, or begin to lose metals that desorb during plant die off. Every 3 to 5 years the entire plant mass including roots should be harvested because the below ground biomass constitutes a significant reservoir (as much as half) of the nutrients and metals that are removed from stormwater by plants.
B	Wetland Cell					Sediment Accumulation	Sediment accumulation inhibits growth of wetland plants or reduces wetland volume (greater than 1 feet of sediment accumulation).	Dredge.
A	Wetland Berms (Dikes)					Settlements	Any part of berm which has settled 4 inches lower than the design elevation. If settlement is apparent, measure berm to determine amount of settlement. Settling can be an indication of more severe problems with the berm or outlet works. A licensed civil engineer should be consulted to determine the source of the settlement.	Dike restored to the design elevation.
A	Wetland Berms (Dikes)					Piping	Discernable water flow through pond berm. Ongoing erosion with potential for erosion to continue. (Recommend a geotechnical engineer be called in to inspect and evaluate condition and recommend repairs.	Piping eliminated. Erosion potential eliminated.
A	Wetland Berms Over 4 ft in height (Dikes)					Tree Growth	Tree growth on berms over 4 feet in height may lead to piping through the berm which could lead to failure of the berm	Trees should be removed. If root system is small (base less than 4 inches) the root system may be left in place. Otherwise the roots should be removed and the berm restored. A licensed civil engineer should be consulted for proper berm/spillway restoration.

Frequency	Drainage System Feature	Date				Problem	Conditions to Check For	Maintenance Activities and Conditions That Should Exist
		✓	✓	✓	✓			
A	Emergency Overflow/ Spillway					Obstruction	Tree growth or other blockage on emergency spillways may cause failure of the berm due to uncontrolled overtopping.	Obstruction should be removed. A licensed civil engineer should be consulted for proper berm/spillway restoration.
A	Emergency Overflow/ Spillway					Rock Missing	Only one layer of rock exists above native soil in an area 5 square feet or larger, or any exposure of native soil at the top of out flow path of spillway. (Riprap on inside slopes need not be replaced.)	Rocks and pad depth are restored to design standards.
A	Emergency Overflow/ Spillway					Erosion	Erosion damage over 2 inches deep where cause of damage is still present or where there is potential for continued erosion. Any erosion observed on a compacted berm embankment.	Slopes should be stabilized using appropriate erosion control measure(s); e.g., rock reinforcement, planting of grass, compaction. If erosion is occurring on compacted berms a licensed civil engineer should be consulted to resolve source of erosion.

If you are unsure whether a problem exists, please contact a professional engineer.

Key:

- (M) Monthly from October through April.
- (A) Once in late summer (preferably September)
- (B) Biannually (once during growing season, once during non-growing season)
- (C) Once in mid summer (late July or early August)
- (S) After any major storm (use 1 inch in 24 hours as a guideline).

#12 – Maintenance Checklist for Wet Vaults

Frequency	Drainage System Feature	Date				Problem	Conditions to Check For	Maintenance Activities and Conditions That Should Exist
		✓	✓	✓	✓			
M	General					Trash/Debris Accumulation	Trash and debris accumulated in vault, pipe or inlet/outlet (includes floatables and non-floatables).	Remove trash and debris from vault.
M	General					Sediment Accumulation in Vault	Sediment accumulation in vault bottom exceeds the depth of the sediment zone plus 6 inches.	Remove sediment from vault. (If sediment contamination is a potential problem, sediment should be tested regularly to determine leaching potential prior to disposal.)
A	General					Damaged Pipes	Inlet/outlet piping damaged or broken and in need of repair.	Pipe repaired and/or replaced.
A	General					Access Cover Damaged/Not Working	Cover cannot be opened or removed, especially by one person.	Pipe repaired or replaced to proper working specifications.
M	General					Ventilation	Ventilation area blocked or plugged.	Blocking material removed or cleared from ventilation area. A specified percentage of the vault surface area must provide ventilation to the vault interior (see design specifications).
A	Vault Structure					Damage - Includes Cracks in Walls Bottom, Damage to Frame and/or Top Slab	Maintenance/inspection personnel determine that the vault is not structurally sound	Vault replaced or repairs made so that vault meets design specifications and is structurally sound.
A	Vault Structure					Damage - Includes Cracks in Walls Bottom, Damage to Frame and/or Top Slab	Cracks wider than one-half-inch at the joint of any inlet/outlet pipe or evidence of soil particles entering through the cracks.	Vault repaired so that no cracks exist wider than one-fourth inch at the joint of the inlet/outlet pipe.
A	Vault Structure					Baffles	Baffles corroding, cracking, warping and/or showing signs of failure as determined by maintenance/inspection staff.	Baffles repaired or replaced to specifications.

Frequency	Drainage System Feature	Date				Problem	Conditions to Check For	Maintenance Activities and Conditions That Should Exist
		✓	✓	✓	✓			
A	Access Ladder					Damage	Ladder is corroded or deteriorated, not functioning properly, not attached to structure wall, missing rungs, has cracks and/or misaligned. Confined space warning sign missing.	Ladder replaced or repaired to specifications, and is safe to use as determined by inspection personnel. Replace sign warning of confined space entry requirements.

If you are unsure whether a problem exists, please contact a professional engineer.

A vault is a confined space. Visual inspections should be performed aboveground. If entry is required it should be performed by qualified personnel.

Key:

- (M) Monthly from October through April.
- (A) Once in late summer (preferably September)
- (S) After any major storm (use 1 inch in 24 hours as a guideline).

Typical Wet Vault

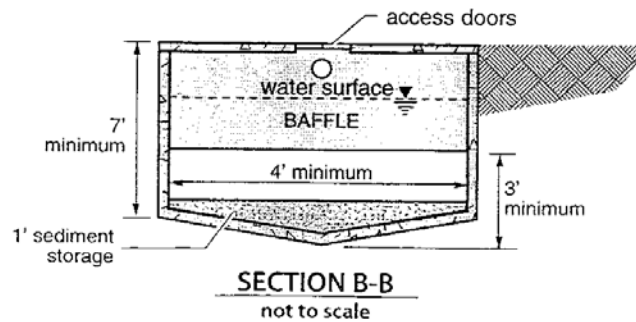
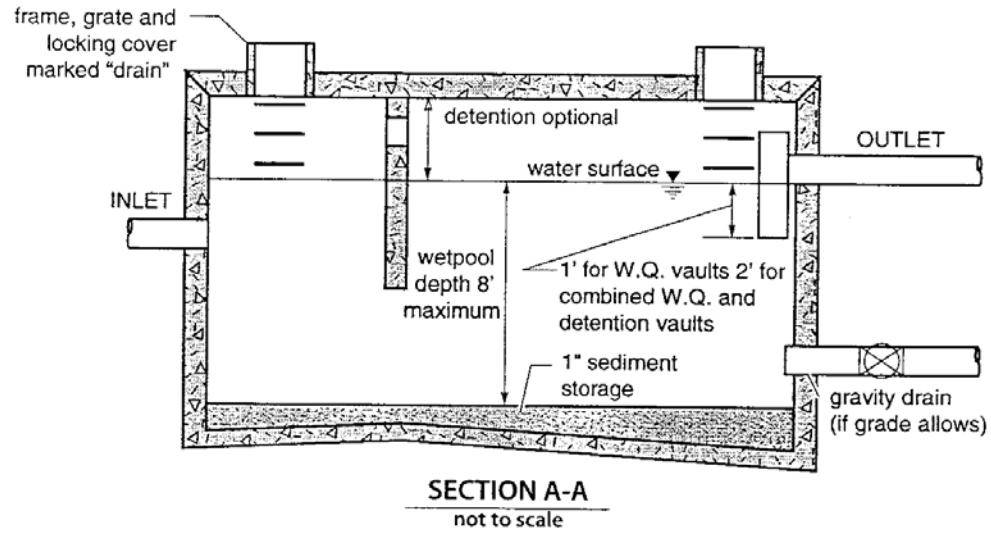
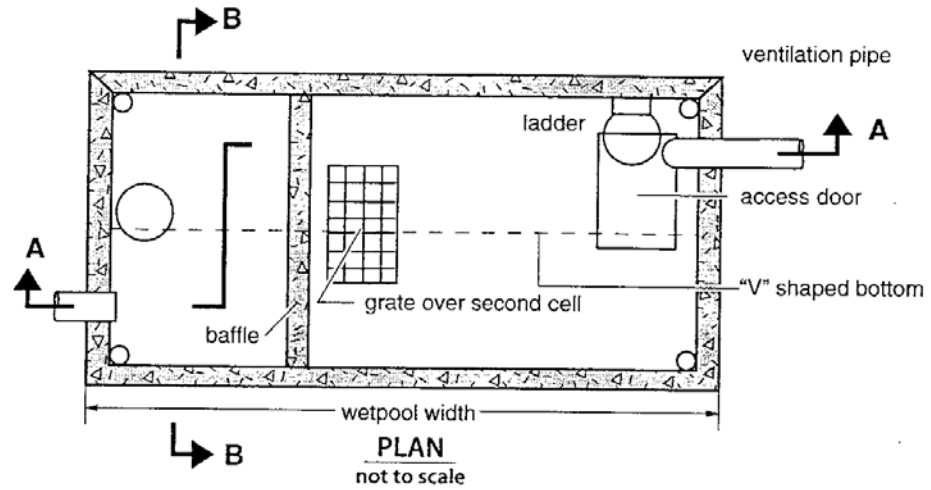

#13 – Maintenance Checklist for Sand Filters (aboveground/open)

Frequency	Drainage System Feature	Date				Problem	Conditions to Check For	Maintenance Activities and Conditions That Should Exist
		✓	✓	✓	✓			
M	Above ground (open sand filter)					Sediment Accumulation on top layer	Sediment depth exceeds one-half inch.	No sediment deposit on grass layer of sand filter that would impede permeability of the filter section.
M	Above ground (open sand filter)					Trash and Debris Accumulations	Trash and debris accumulated on sand filter bed.	Trash and debris removed from sand filter bed.
M	Above ground (open sand filter)					Sediment/ Debris in Clean-Outs	When the clean-outs become full or partially plugged with sediment and/or debris.	Sediment removed from clean-outs.
M	Above ground (open sand filter)					Sand Filter Media	Drawdown of water through the sand filter media takes longer than 24-hours, and/or flow through the overflow pipes occurs frequently.	Top several inches of sand are scraped. May require replacement of entire sand filter depth depending on extent of plugging (a sieve analysis is helpful to determine if the lower sand has too high a proportion of fine material). Other options include removal of thatch, aerating the filter surface, tilling the filter surface, replacing the top 4 inches of filter media, and inspecting geotextiles for clogging.
M	Above ground (open sand filter)					Prolonged Flows	Sand is saturated for prolonged periods of time (several weeks) and does not dry out between storms due to continuous base flow or prolonged flows from detention facilities. (Consider 4-8 hour drawdown tests)	Low, continuous flows are limited to a small portion of the facility by using a low wooden divider or slightly depressed sand surface.
M	Above ground (open sand filter)					Short Circuiting	Drawdown greater than 12 inches per hour. When flows become concentrated over one section of the sand filter rather than dispersed. (Consider 4-8 hour drawdown tests)	Flow and percolation of water through sand filter is uniform and dispersed across the entire filter area.

Frequency	Drainage System Feature	Date				Problem	Conditions to Check For	Maintenance Activities and Conditions That Should Exist
		✓	✓	✓	✓			
M	Above ground (open sand filter)					Erosion Damage to Slopes	Erosion over 2 inches deep where cause of damage is prevalent or potential for continued erosion is evident.	Slopes stabilized using proper erosion control measures.
A	Above ground (open sand filter)					Rock Pad Missing or Out of Place	Soil beneath the rock is visible.	Rock pad replaced or rebuilt to design specifications.
M	Above ground (open sand filter)					Flow Spreader	Flow spreader uneven or clogged so that flows are not uniformly distributed across sand filter. Rills and gullies on the surface of the filter can indicate improper function of the inlet flow spreader.	Spreader leveled and cleaned so that flows are spread evenly over sand filter.
M	Above ground (open sand filter)					Damaged Pipes	Any part of the piping that is crushed or deformed more than 20 percent or any other failure to the piping.	Pipe repaired or replaced.

If you are unsure whether a problem exists, please contact a professional engineer.

Key:

- (M) Monthly from October through April.
- (A) Once in late summer (preferably September)
- (S) After any major storm (use 1 inch in 24 hours as a guideline).

#14 – Maintenance Checklist for Sand Filters (below ground/enclosed)

Frequency	Drainage System Feature	Date				Problem	Conditions to Check For	Maintenance Activities and Conditions That Should Exist
		✓	✓	✓	✓			
M	Below Ground Vault					Sediment Accumulation on Sand Media Section	Sediment depth exceeds one-half inch.	No sediment deposits on sand filter section that which would impede permeability of the filter section.
M	Below Ground Vault					Sediment Accumulation in Presettling Portion of Vault	Sediment accumulation in vault bottom exceeds the depth of the sediment zone plus 6 inches.	No sediment deposits in first chamber of vault.
M	Below Ground Vault					Trash/Debris Accumulation	Trash and debris accumulated in vault, or pipe inlet/outlet, floatables and non-floatables.	Trash and debris removed from vault and inlet/outlet piping.
M	Below Ground Vault					Sediment in Drain Pipes/Cleanouts	When drain pipes, cleanouts become full with sediment and/or debris.	Sediment and debris removed.
M	Below Ground Vault					Clogged Sand Filter Media	Drawdown of water through the sand filter media takes longer than 24-hours, and/or flow through the overflow pipes occurs frequently. (Consider 4-8 hour drawdown tests.)	Top several inches of sand are scraped. May require replacement of entire sand filter depth depending on extent of plugging (a sieve analysis is helpful to determine if the lower sand has too high a proportion of fine material). Other options include removal of thatch, aerating the filter surface, tilling the filter surface, and replacing the top 4 inches of filter media.
M	Below Ground Vault					Short Circuiting	Drawdown greater than 12 inches per hour. When seepage/flow occurs along the vault walls and corners. Sand eroding near inflow area. (Consider 4-8 hour drawdown tests.)	Sand filter media section re-laid and compacted along perimeter of vault to form a semi-seal. Erosion protection added to dissipate force of incoming flow and curtail erosion.
A	Below Ground Vault					Damaged Pipes	Inlet or outlet piping damaged or broken and in need of repair.	Pipe repaired and/or replaced.
M	Below Ground Vault					Flow Spreader	Flow spreader uneven or clogged so that flows are not uniformly distributed across sand filter.	Spreader leveled and cleaned so that flows are spread evenly over sand filter.

Frequency	Drainage System Feature	Date				Problem	Conditions to Check For	Maintenance Activities and Conditions That Should Exist
		✓	✓	✓	✓			
M	Below Ground Vault					Ventilation	Ventilation area blocked or plugged	Blocking material removed or cleared from ventilation area. A specified percentage of the vault surface area must provide ventilation to the vault interior (see design specifications).
A	Below Ground Vault					Access Cover Damaged/Not Working	Cover cannot be opened, corrosion/deformation of cover. Maintenance person cannot remove cover using normal lifting pressure.	Cover repaired to proper working specifications or replaced.
A	Below Ground Vault					Vault Structure Damaged; Includes Cracks in Walls, Bottom, Damage to Frame and/or Top Slab.	Cracks wider than one-half inch or evidence of soil particles entering the structure through the cracks, or maintenance/inspection personnel determine that the vault is not structurally sound.	Vault replaced or repairs made so that vault meets design specifications and is structurally sound.
A	Below Ground Vault					Vault Structure Damaged; Includes Cracks in Walls, Bottom, Damage to Frame and/or Top Slab.	Cracks wider than one-half inch at the joint of any inlet/outlet pipe or evidence of soil particles entering through the cracks.	Vault repaired so that no cracks exist wider than one-fourth inch at the joint of the inlet/outlet pipe.
A	Below Ground Vault					Baffles/Internal walls	Baffles or walls corroding, cracking, warping and/or showing signs of failure as determined by maintenance/inspection person.	Baffles repaired or replaced to specifications.
A	Below Ground Vault					Access Ladder	Damaged Ladder is corroded or deteriorated, not functioning properly, not securely attached to structure wall, missing rungs, cracks, and misaligned.	Ladder replaced or repaired to specifications, and is safe to use as determined by inspection personnel.

If you are unsure whether a problem exists, please contact a professional engineer.

A below ground enclosed sand filter is a confined space. Visual inspections should be performed aboveground. If entry is required it should be performed by qualified personnel.

Key:

- (M) Monthly from October through April.
- (A) Once in late summer (preferably September)
- (S) After any major storm (use 1 inch in 24 hours as a guideline).

#15 – Maintenance Checklist for Stormfilter™ Cast-In-Place, Precast, Linear Stormfilter Units and Catch Basin Units by Contech Stormwater Solutions. Also check DOE website and manufacturer guidelines for updates to O&M requirements.

Frequency	Drainage System Feature	Date				Problem	Conditions to Check For	Maintenance Activities and Conditions That Should Exist
		✓	✓	✓	✓			
M	Media filter vault					Sediment accumulation on top of filter cartridges	Sediment accumulation exceeds 0.25 inches on top of cartridges.	No sediment deposits on top of cartridges. Sediment on cartridges likely indicates that cartridges are plugged and require maintenance.
M	Media filter vault					Sediment accumulation in vault	Sediment accumulation in vault exceeds 0.5 inches. Look for other indicators of clogged cartridges or overflow.	Sediment in vault should be removed. Cartridges should be checked and replaced or serviced as needed.
M	Media filter vault					Trash and floatable debris accumulation	Trash and floatable debris accumulation in vault	No trash or other floatable debris in filter vault.
S	Media filter vault					Filter cartridges submerged	Filter vault does not drain within 24 hours following storm. Look for evidence of submergence due to backwater or excessive hydrocarbon loading.	Filter media checked and replaced if needed. If cartridges are plugged with oil additional treatment or source control BMP may be needed.
M	Forebay					Sediment accumulation	Sediment accumulation exceeds 6 inches or one-third of the of available sump.	Sediment accumulation less than 6 inches.
M	Forebay					Trash and floatable debris accumulation	Trash and/or floatable debris accumulation.	Trash and/or floatable debris should be removed during monthly inspections. Significant oil accumulation may indicate the need for additional treatment or source control.
A	Drain Pipes/ Cleanouts					Sediment in Drain Pipes/Clean-Outs	When drain pipes, clean-outs, become full with sediment and/or debris.	Sediment and debris removed.
A	Below ground vault					Access cover Damaged/ Not working	One maintenance person cannot remove lid after applying 80 pounds of lift, corrosion of deformation of cover.	Cover repaired to proper working specifications or replaced.
A	Below ground vault					Damaged Pipes	Any part of the pipes are crushed or damaged due to corrosion and/or settlement.	Pipe repaired or replaced.

Frequency	Drainage System Feature	Date				Problem	Conditions to Check For	Maintenance Activities and Conditions That Should Exist
		✓	✓	✓	✓			
A	Below ground vault					Vault structure has cracks in wall, bottom, and damage to frame and/or top slab.	Cracks wider than one-half inch or evidence of soil particles entering the structure through the cracks, or maintenance/inspection personnel determine that the vault is not structurally sound.	Vault repaired or replaced so that vaults meets design specifications and is structurally sound.
A	Below ground vault					Vault structure has cracks in wall, bottom, and damage to frame and/or top slab.	Cracks wider than 0.5 inch at the joint of any inlet/outlet pipe or evidence of soil particles entering through the cracks	Vault repaired so that no cracks exist wider than 0.25 inch at the joint of inlet/outlet pipe.
A	Below ground vault					Baffles	Baffles corroding, cracking , warping, and/or showing signs of failure as determined by maintenance/inspection person	Baffles repaired or replaced to design specifications.
A	Below ground vault					Ladder rungs unsafe	Maintenance person judges that ladder is unsafe due to missing rungs, misalignment, rust, or cracks. Ladder must be fixed or secured immediately.	Ladder meets design standards and allows maintenance persons safe access.
S	Below Ground Cartridge Type					Compost Media	Drawdown of water through the media takes longer than 1 hour, and/or overflow occurs frequently.	Media cartridges replaced.
S	Below Ground Cartridge Type					Short Circuiting	Flows do not properly enter filter cartridges.	Filter cartridges replaced.

If you are unsure whether a problem exists, please contact a professional engineer.

A vault is a confined space. Visual inspections should be performed aboveground. If entry is required it should be performed by qualified personnel.

Key:

- (M) Monthly from October through April.
- (A) Once in late summer (preferably September)
- (S) After any major storm (use 1 inch in 24 hours as a guideline).

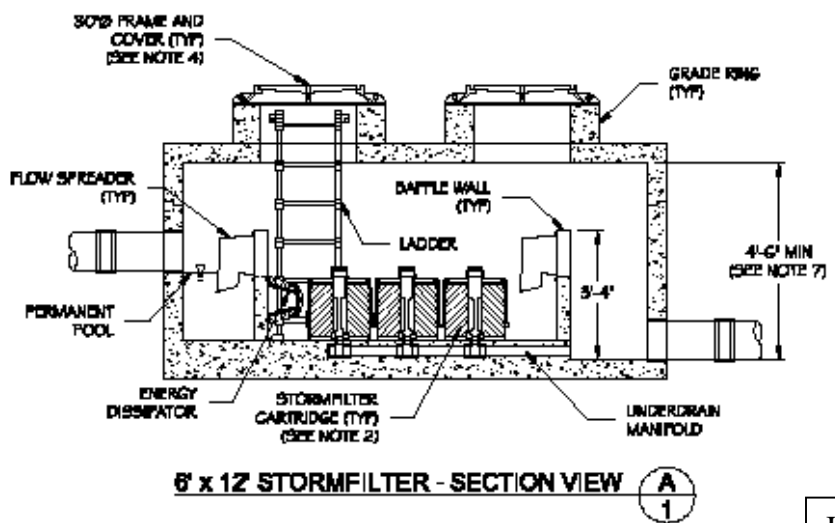
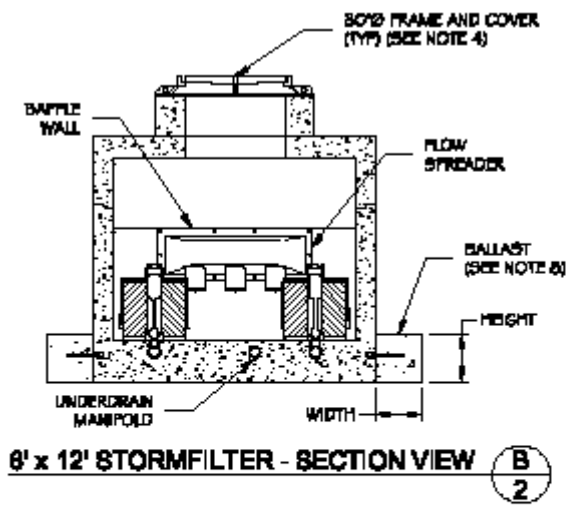
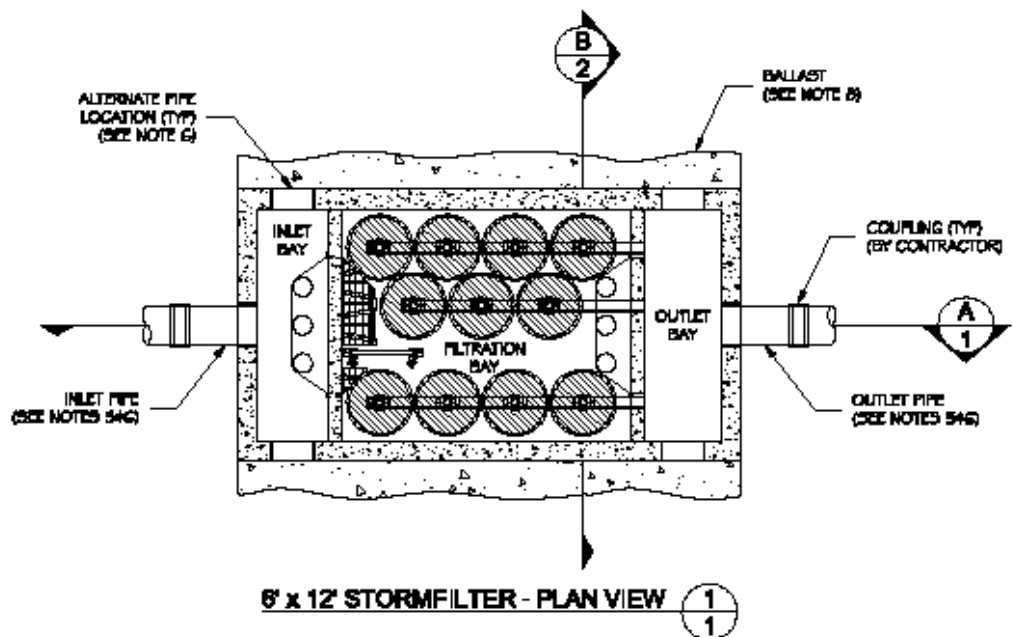

Images copyrighted by Contech Stormwater Solutions Inc.

#16 – Maintenance Checklist for Baffle Oil/Water Separators (American Petroleum Institute [API] Type)

Frequency	Drainage System Feature	Date				Problem	Conditions to Check For	Maintenance Activities and Conditions That Should Exist
		✓	✓	✓	✓			
M,S	Monitoring					Inspection of discharge water for obvious signs of poor water quality.	Sheen, obvious oil present	Effluent discharge from vault should be clear with out thick visible sheen.
M,S	Monitoring					Sediment Accumulation	Sediment depth in bottom of vault exceeds 6 inches in depth.	No sediment deposits on vault bottom that would impede flow through the vault and reduce separation efficiency.
M,S	Monitoring					Trash and Debris Accumulation	Trash and debris accumulation in vault, or pipe inlet/outlet, floatables and non-floatables.	Trash and debris removed from vault, and inlet/outlet piping.
M,S	Monitoring					Oil Accumulation	Oil accumulations that exceed 1 inch, at the surface of the water or 6 inches of sludge in the sump.	Extract oil/sludge from vault by vactoring. Disposal in accordance with state and local rules and regulations.
A	Structure					Damaged Pipes	Inlet or outlet piping damaged or broken and in need of repair.	Pipe repaired or replaced.
A	Structure					Access Cover Damaged/Not Working	Cover cannot be opened, corrosion/deformation of cover.	Cover repaired to proper working specifications or replaced.
A	Structure					Vault Structure Damage Includes Cracks in Walls Bottom, Damage to Frame and/or Top Slab	Maintenance person judges that structure is unsound.	Vault replaced or repairs made so that vault meets design specifications and is structurally sound.
A	Structure					Vault Structure Damage Includes Cracks in Walls Bottom, Damage to Frame and/or Top Slab	Cracks wider than one-half inch at the joint of any inlet/outlet pipe or evidence of soil particles entering through the cracks.	Vault repaired so that no cracks exist wider than one-fourth inch at the joint of the inlet/outlet pipe.
A	Structure					Baffles	Baffles corroding, cracking, warping and/or showing signs of failure as determined by maintenance/inspection person.	Baffles repaired or replaced to specifications.

Frequency	Drainage System Feature	Date				Problem	Conditions to Check For	Maintenance Activities and Conditions That Should Exist
		✓	✓	✓	✓			
A	Structure					Access Ladder Damaged	Ladder is corroded or deteriorated, not functioning properly, not securely attached to structure wall, missing rungs, cracks, and misaligned.	Ladder replaced or repaired and meets specifications, and is safe to use as determined by inspection personnel.

If you are unsure whether a problem exists, please contact a professional engineer.

An oil/water separator vault is a confined space. Visual inspections should be performed aboveground. If entry is required it should be performed by qualified personnel.

Key:

- (M) Monthly from October through April.
- (A) Once in late summer (preferably September)
- (S) After any major storm (use 1 inch in 24 hours as a guideline).

#17 – Maintenance Checklist for Coalescing Plate Oil/Water Separators

Frequency	Drainage System Feature	Date				Problem	Conditions to Check For	Maintenance Activities and Conditions That Should Exist
		✓	✓	✓	✓			
M,S	General					Monitoring	Inspection of discharge water for obvious signs of poor water quality.	Effluent discharge from vault should be clear with no thick visible sheen.
M,S	General					Sediment Accumulation	Sediment depth in bottom of vault exceeds 6 inches in depth and/or visible signs of sediment on plates.	No sediment deposits on vault bottom and plate media, which would impede flow through the vault and reduce separation efficiency.
M,S	General					Trash and Debris Accumulation	Trash and debris accumulated in vault, or pipe inlet/outlet, floatables and non-floatables.	Trash and debris removed from vault, and inlet/outlet piping.
M,S	General					Oil Accumulation	Oil accumulation that exceeds 1 inch at the water surface.	Oil is extracted from vault using vactoring methods. Dispose of in accordance with state and local rules and regulations. Coalescing plates are cleaned by thoroughly rinsing and flushing. Direct wash-down effluent to the sanitary sewer system where permitted. Should be no visible oil depth on water.
A	Structure					Damaged Coalescing Plates	Plate media broken, deformed, cracked and/or showing signs of failure.	A portion of the media pack or the entire plate pack is replaced depending on severity of failure.
A	Structure					Damaged Pipes	Inlet or outlet piping damaged or broken and in need of repair.	Pipe repaired and or replaced.
A	Structure					Baffles	Baffles corroding, cracking, warping and/or showing signs of failure as determined by maintenance/inspection person.	Baffles repaired or replaced to specifications.
A	Structure					Vault Structure Damage - Includes Cracks in Walls, Bottom, Damage to Frame and/or Top Slab	Cracks wider than one-half inch or evidence of soil particles entering the structure through the cracks, or maintenance/inspection personnel determine that the vault is not structurally sound.	Vault replaced or repairs made so that vault meets design specifications and is structurally sound.

Frequency	Drainage System Feature	Date				Problem	Conditions to Check For	Maintenance Activities and Conditions That Should Exist
		✓	✓	✓	✓			
A	Structure					Vault Structure Damage - Includes Cracks in Walls, Bottom, Damage to Frame and/or Top Slab	Cracks wider than one-half inch at the joint of any inlet/outlet pipe or evidence of soil particles entering through the cracks.	Vault repaired so that no cracks exist wider than one-fourth inch at the joint of the inlet/outlet pipe.
A	Structure					Access Ladder Damaged	Ladder is corroded or deteriorated, not functioning properly, not securely attached to structure wall, missing rungs, cracks, and misaligned.	Ladder replaced or repaired and meets specifications, and is safe to use as determined by inspection personnel.

If you are unsure whether a problem exists, please contact a professional engineer.

An oil/water separator vault is a confined space. Visual inspections should be performed aboveground. If entry is required it should be performed by qualified personnel.

Key:

- (M) Monthly from October through April.
- (A) Once in late summer (preferably September)
- (S) After any major storm (use 1 inch in 24 hours as a guideline).

#19 – Maintenance Checklist for Fencing/Shrubbery Screen/Other Landscaping

Frequency	Drainage System Feature	Date				Problem	Conditions to Check For	Maintenance Activities and Conditions That Should Exist
		✓	✓	✓	✓			
M	General					Missing or broken parts/dead shrubbery	Any defect in the fence or screen that permits easy entry to a facility.	Fence is mended or shrubs replaced to form a solid barrier to entry.
M,S	General					Erosion	Erosion has resulted in an opening under a fence that allows entry by people or pets.	Replace soil under fence so that no opening exceeds 4 inches in height.
M	General					Unruly Vegetation	Shrubbery is growing out of control or is infested with weeds. See also Kitsap County Noxious weeds list.	Shrubbery is trimmed and weeded to provide appealing aesthetics. Do not use chemicals to control weeds.
A	Fences					Damaged Parts	Posts out of plumb more than 6 inches.	Posts plumb to within 1.5 inches of plumb.
A	Fences					Damaged Parts	Top rails bent more than 6 inches.	Top rail free of bends greater than 1 inch.
A	Fences					Damaged Parts	Any part of fence (including posts, top rails, and fabric) more than 1 foot out of design alignment.	Fence is aligned and meets design standards.
A	Fences					Damaged Parts	Missing or loose tension wire.	Tension wire in place and holding fabric.
A	Fences					Damaged Parts	Missing or loose barbed wire that is sagging more than 2.5 inches between posts.	Barbed wire in place with less than three-fourth inch sag between posts.
A	Fences					Damaged Parts	Extension arm missing, broken, or bent out of shape more than 1.5 inches.	Extension arm in place with no bends larger than three-fourth inch.
A	Fences					Deteriorated Paint or Protective Coating	Part or parts that have a rusting or scaling condition that has affected structural adequacy.	Structurally adequate posts or parts with a uniform protective coating.
M	Fences					Openings in Fabric	Openings in fabric are such that an 8-inch diameter ball could fit through.	No openings in fabric.

If you are unsure whether a problem exists, please contact a professional engineer.

Key:

- (M) Monthly from October through April.
- (A) Once in late summer (preferably September)
- (S) After any major storm (use 1 inch in 24 hours as a guideline).

#20 – Maintenance Checklist for Gates

Frequency	Drainage System Feature	Date				Problem	Conditions to Check For	Maintenance Activities and Conditions That Should Exist
		✓	✓	✓	✓			
M	General					Damaged or Missing Components	Gate is broken, jammed, or missing.	Pond has a functioning gate to allow entry of people and maintenance equipment such as mowers and backhoe. If a lock is used, make sure the county field staff have a key.
M	General					Damaged or Missing Components	Broken or missing hinges such that gate cannot be easily opened and closed by one maintenance person.	Hinges intact and lubed. Gate is working freely.
A	General					Damaged or Missing Components	Gate is out of plumb more than 6 inches and more than 1 foot out of design alignment.	Gate is aligned and vertical.
A	General					Damaged or Missing Components	Missing stretcher bands, and ties.	Stretcher bar, bands, and ties in place.

If you are unsure whether a problem exists, please contact a professional engineer.

Key:

- (M) Monthly from October through April.
- (A) Once in late summer (preferably September)
- (S) After any major storm (use 1 inch in 24 hours as a guideline).

#21 – Maintenance Checklist for Grounds (Landscaping)

Frequency	Drainage System Feature	Date				Problem	Conditions to Check For	Maintenance Activities and Conditions That Should Exist
		✓	✓	✓	✓			
M	General					Weeds (nonpoisonous)	Weeds growing in more than 20 percent of the landscaped area (trees and shrubs only). See also Kitsap County Noxious weeds list.	Weeds present in less than 5 percent of the landscaped area.
M	General					Insect Hazard	Any presence of poison ivy or other poisonous vegetation or insect nests.	No poisonous vegetation or insect nests present in landscaped area.
M,S	General					Trash or Litter	See Ponds Checklist.	See Ponds Checklist.
M,S	General					Erosion of Ground Surface	Noticeable rills are seen in landscaped areas.	Causes of erosion are identified and steps taken to slow down/spread out the water. Eroded areas are filled, contoured, and seeded.
A	Trees and shrubs					Damage	Limbs or parts of trees or shrubs that are split or broken which affect more than 25 percent of the total foliage of the tree or shrub.	Trim trees/shrubs to restore shape. Replace trees/shrubs with severe damage.
M	Trees and shrubs					Damage	Trees or shrubs that have been blown down or knocked over.	Replant tree, inspecting for injury to stem or roots. Replace if severely damaged.
A	Trees and shrubs					Damage	Trees or shrubs which are not adequately supported or are leaning over, causing exposure of the roots.	Place stakes and rubber-coated ties around young trees/shrubs for support.

If you are unsure whether a problem exists, please contact a professional engineer.

Key:

- (M) Monthly from October through April.
- (A) Once in late summer (preferably September)
- (S) After any major storm (use 1 inch in 24 hours as a guideline).

#22 – Maintenance Checklist for Media Filter Drain (Formerly known as the WSDOT Ecology Embankment)

Frequency	Drainage System Feature	Date				Problem	Conditions to Check For	Maintenance Activities and Conditions That Should Exist
		✓	✓	✓	✓			
M	No Vegetation Zone adjacent to pavement					Erosion, Scour, or Vehicular Damage	No vegetation zone uneven or clogged so that flows are not uniformly distributed.	Level the area and clean so that flows are spread evenly.
M	No Vegetation Zone adjacent to pavement					Sediment Accumulation on Edge of Pavement	Flows no longer sheeting off of roadway. Sediment accumulation on pavement edge exceeds top of pavement elevation.	Remove sediment deposits such that flows can sheet off of roadway.
M	Vegetated Filter					Sediment Accumulation on Grass	Sediment depth exceeds 2 inches.	Remove sediment deposits, re-level so slope is even and flows pass evenly through Ecology Embankment.
M	Vegetated Filter					Excessive Vegetation or Undesirable Species	When the grass becomes excessively tall; when nuisance weeds and other vegetation starts to take over or shades out desirable vegetation growth characteristics. See also Kitsap County Noxious weeds list.	Mow grass, control nuisance vegetation, such that flow not impeded. Grass should be mowed to a height that encourages dense even herbaceous growth.
M	Vegetated Filter					Erosion, Scour, or Vehicular Damage	Eroded or scoured areas due to flow channelization, high flows or vehicular damage.	For ruts or bare areas less than 12 inches wide, repair the damaged area by filling with suitable topsoil. The grass will creep in over the rock in time. If bare areas are large, generally greater than 12 inches wide, the filter strip should be re-graded and re-seeded. For smaller bare areas, overseed when bare spots are evident.
M	Media Bed					Erosion, Scour, or Vehicular Damage	Eroded or scoured areas due to flow channelization, high flows or vehicular damage.	For ruts or areas less than 12 inches wide, repair the damaged area by filling with suitable media. If bare areas are large, generally greater than 12 inches wide, the media bed should be re-graded.

Frequency	Drainage System Feature	Date				Problem	Conditions to Check For	Maintenance Activities and Conditions That Should Exist
		✓	✓	✓	✓			
M	Media Bed					Sediment Accumulation on Media Bed	Sediment depth inhibits free infiltration of water.	Remove sediment deposits, re-level so slope is even and flows pass freely through Media Bed.
M	Underdrains					Sediment	Depth of sediment within perforated pipe exceeds one-half inch.	Flush underdrains through access ports and collect flushed sediment.
M	General					Trash and Debris Accumulation	Trash and debris which exceed 5 cubic feet per 1,000 square feet (this is about equal to the amount of trash it would take to fill up one 32 gallon garbage can). In general, there should be no visual evidence of dumping. If less than threshold all trash and debris will be removed as part of next scheduled maintenance.	Remove trash and debris.
M	General					Flows are Bypassing Ecology Embankment	Evidence of significant flows downslope (rills, sediment, vegetation damage, etc.) of Ecology Embankment.	Remove sediment deposits, re-level so slope is even and flows pass evenly through Ecology Embankment. If Ecology Embankment is completely clogged it may require a more extensive repair or replacement.

If you are unsure whether a problem exists, please contact a professional engineer.

Key:

- (M) Monthly from October through April.
- (A) Once in late summer (preferably September)
- (S) After any major storm (use 1 inch in 24 hours as a guideline).

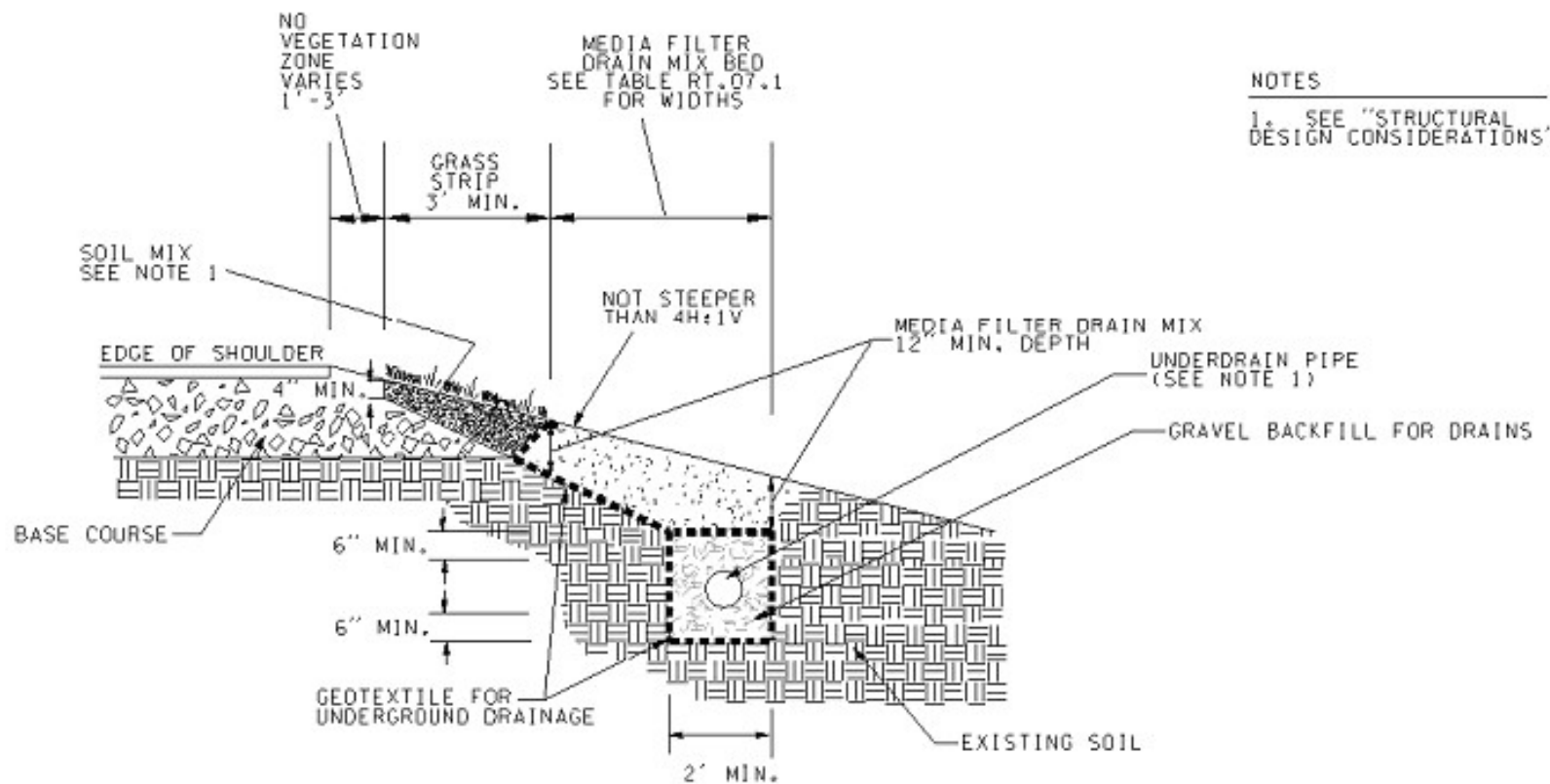

NOTES
 1. SEE "STRUCTURAL DESIGN CONSIDERATIONS"

MEDIA FILTER DRAIN
 SIDE SLOPE APPLICATION WITH UNDERDRAIN

NTS

THIS DRAWING IS ONLY A TEMPLATE AND SHOULD BE MODIFIED TO FIT EACH PROJECT APPLICATION

#23 – Maintenance Checklist for Vortechs Stormwater Treatment System by Contech Stormwater Solutions. Also check DOE website and manufacturer guidelines for updates to O&M requirements.

Frequency	Drainage System Feature	Date				Problem	Conditions to Check For	Maintenance Activities and Conditions That Should Exist
		✓	✓	✓	✓			
M,S	General					Sediment accumulation	Sediment depth is within 6 inches of dry weather water surface elevation.	Accumulated sediment should be removed.
M,S	General					Trash and Debris Accumulation	Trash and debris accumulated in vault, or pipe inlet/outlet, floatables and non-floatables.	Trash and debris removed from vault, and inlet/outlet piping.
M,S	General					Oil Accumulation	Oil accumulation that exceeds 1 inch at the water surface.	Oil is extracted from vault using vactoring methods. Coalescing plates are cleaned by thoroughly rinsing and flushing. Should be no visible oil depth on water.
A	Structure					Damaged Pipes	Inlet or outlet piping damaged or broken and in need of repair.	Pipe repaired and or replaced.
A	Structure					Baffles	Baffles corroding, cracking, warping and/or showing signs of failure as determined by maintenance/inspection person.	Baffles repaired or replaced to specifications.
A	Structure					Vault Structure Damage - Includes Cracks in Walls, Bottom, Damage to Frame and/or Top Slab	Cracks wider than one-half inch or evidence of soil particles entering the structure through the cracks, or maintenance/inspection personnel determine that the vault is not structurally sound.	Vault replaced or repairs made so that vault meets design specifications and is structurally sound.
A	Structure					Vault Structure Damage - Includes Cracks in Walls, Bottom, Damage to Frame and/or Top Slab	Cracks wider than one-half inch at the joint of any inlet/outlet pipe or evidence of soil particles entering through the cracks.	Vault repaired so that no cracks exist wider than one-fourth inch at the joint of the inlet/outlet pipe.

If you are unsure whether a problem exists, please contact a professional engineer.

A vault is a confined space. Visual inspections should be performed aboveground. If entry is required it should be performed by qualified personnel.

Key:

A=Annual (March or April preferred)

M=Monthly (see schedule)

S=After major storms (use 1 inch in 24 hours as a guideline)

#24 – Maintenance Checklist for Stormceptor System. Also check DOE website and manufacturer guidelines for updates to O&M requirements.

Frequency	Drainage System Feature	Date				Problem	Conditions to Check For	Maintenance Activities and Conditions That Should Exist
		✓	✓	✓	✓			
M	Settling chamber					Excessive sediment Accumulation	Capacities vary depending on model number. See Table Below.	Sediments should be removed.
M	Settling chamber					Trash and Floatable Debris Accumulation	Excessive trash and floatable debris accumulation.	Minimal trash or other floatable debris.
M	Settling chamber					Excessive Oil Accumulation	Oil exceeds 6 inches in depth or evidence of a spill	Oil should be cleaned out.
M	Manhole Cover					Cover Damaged/ Not Working	One maintenance person cannot remove lid after applying 80 pounds of lift, corrosion of deformation of cover.	Cover repaired to proper working specifications or replaced.
M	Disk Insert					Disk Insert Inlet/ Outlet Obstructed	Inlet or outlet piping obstructed	Disk insert inlet/outlet free from obstructions.
A	Structure					Structure has Cracks in wall, Bottom, and Damage to Frame and/or Top Slab.	Cracks wider than one-half inch or evidence of soil particles entering the structure through the cracks, or maintenance/inspection personnel determine that the vault is not structurally sound.	Vault repaired or replaced so that vaults meets design specifications and is structurally sound.
A	Structure					Structure has Cracks at the Joint of any Inlet/ Outlet Pipe.	Cracks wider than one-half inch at the joint of any inlet/outlet pipe or evidence of soil particles entering through the cracks	Vault repaired so that no cracks exist wider than one-fourth inch at the joint of inlet/outlet pipe.

If you are unsure whether a problem exists, please contact a professional engineer or the manufacturer's representative.

Comments:

Sediment Depths Indicating Required Servicing	
Model	Sediment Depth
STC 450i	8"
STC 900	8"
STC 1200	10"
STC 1800	15"
STC 2400	12"
STC 3600	17"
STC 4800	15"
STC 6000	18"
STC 7200	15"
STC 11000	15"
STC 13000	18"
STC 16000	15"

Key:

- (M) Monthly from October through April.
- (A) Once in late summer (preferably September).
- (S) After any major storm (use 1 inch in 24 hours as a guideline).

STC 450i Precast Concrete Stormceptor[®]
(450 U.S. Gallon Capacity)

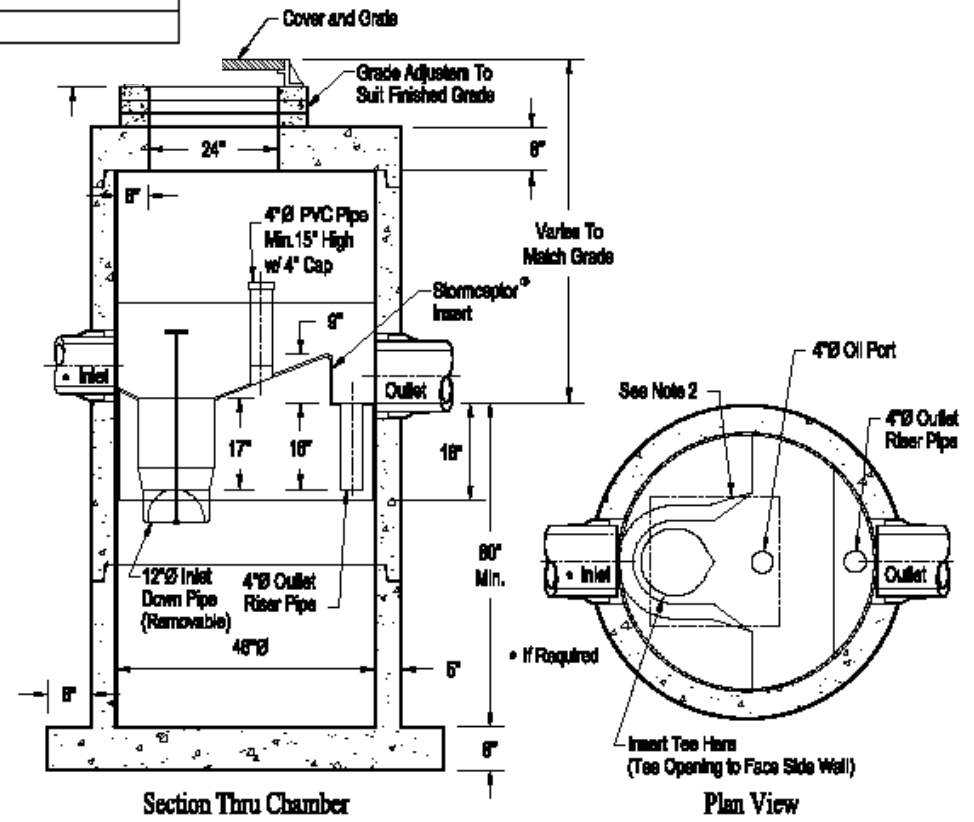

#26 – Maintenance Checklist for Filterra. Also check DOE website and manufacturer guidelines for updates to O&M requirements.

Frequency	Drainage System Feature	Date				Problem	Conditions to Check For	Maintenance Activities and Conditions That Should Exist
		✓	✓	✓	✓			
M	Inlet					Excessive Sediment or Trash Accumulation	Accumulated sediments or trash impair free flow of water into Filterra	Inlet should be free of obstructions allowing free distributed flow of water into Filterra. Sediments and/or trash should be removed.
M	Mulch Cover					Trash and Floatable Debris Accumulation	Excessive trash and/or debris accumulation.	Minimal trash or other debris on mulch cover. Trash and debris should be removed and mulch cover raked level.
M	Mulch Cover					Ponding of Water on Mulch Cover.	Ponding in unit could be indicative of clogging due to excessive fine sediment accumulation or spill of petroleum oils.	Stormwater should drain freely and evenly through mulch cover. Recommend contact manufacturer and replace mulch or soil if necessary.
M	Vegetation					Plants not Growing or in Poor Condition.	Soil/ mulch too wet, evidence of spill. Incorrect plant selection. Pest infestation. Vandalism to plants.	Plants should be healthy and pest free. Contact manufacturer for advice.
M	Vegetation					Plant Growth Excessive	Plants should be appropriate to the species and location of Filterra.	Trim/prune plants in accordance with manufacturers recommendations.
A	Structure					Structure has Cracks in Wall, Bottom, and Damage to Frame and/or Top Slab.	Cracks wider than one-half inch or evidence of soil particles entering the structure through the cracks, or maintenance/inspection personnel determine that the vault is not structurally sound.	Vault repaired or replaced so that vaults meets design specifications and is structurally sound.
A	Structure					Structure has Cracks at the Joint of any Inlet/ Outlet Pipe.	Cracks wider than one-half inch at the joint of any inlet/outlet pipe or evidence of soil particles entering through the cracks	Vault repaired so that no cracks exist wider than one-fourth inch at the joint of inlet/outlet pipe.

If you are unsure whether a problem exists, please contact a professional engineer or the manufacturer's representative.

Comments:

Key:

- (M) Monthly from October through April.
- (A) Once in late summer (preferably September).
- (S) After any major storm (use 1 inch in 24 hours as a guideline).

#27 – Maintenance Checklist for CDS Media Filtration System (MFS)® by Contech Stormwater Solutions. Also check DOE website and manufacturer guidelines for updates to O&M requirements.

Frequency	Drainage System Feature	Date				Problem	Conditions to Check For	Maintenance Activities and Conditions That Should Exist
		✓	✓	✓	✓			
M	Media filter vault					Sediment Accumulation on Top of Filter Cartridges	Sediment accumulation exceeds one-half inch on top of cartridges.	Minimal sediment deposits on top of cartridges. Excess sediment on cartridges likely indicates that cartridges are plugged and require maintenance.
M	Media filter vault					Sediment Accumulation in Vault	Sediment accumulation in vault exceeds 6 inches.	Sediment in vault should be removed.
M	Media filter vault					Trash and Floatable Debris Accumulation	Excessive trash and floatable debris accumulation in vault.	Minimal trash or other floatable debris in filter vault.
M	Media filter cartridges					Filter Cartridges Full	Filter cartridge media appears dark. Check should be performed on a dry day. Requires entry to vault. See comments below.	Filter media checked and replaced if needed. If cartridges are plugged with oil additional treatment or source control BMP may be needed.
M	Media filter cartridges					Filter Cartridges Full	Area around cartridges has standing water and cartridges are submerged 24 hours after a storm.	Filter media checked and replaced if needed. If cartridges are plugged with oil additional treatment or source control BMP may be needed.
M	Media filter cartridges					Filter Cartridges Full	Water flowing over the head control box during light storm events and more than 1 inch of floatables has accumulated in the cartridge vent pipe.	Filter media checked and replaced if needed. If cartridges are plugged with oil additional treatment or source control BMP may be needed.
M	Access Cover					Access Cover Damaged/ Not Working	One maintenance person cannot remove lid after applying 80 pounds of lift, corrosion of deformation of cover.	Cover repaired to proper working specifications or replaced.
A	Collector manifold					Damaged Piping	Any part of the pipes are crushed or damaged due to corrosion and/or settlement.	Pipe repaired or replaced.

Frequency	Drainage System Feature	Date				Problem	Conditions to Check For	Maintenance Activities and Conditions That Should Exist
		✓	✓	✓	✓			
A	Vault					Vault Structure has Cracks in Wall, Bottom, and Damage to Frame and/or Top Slab.	Cracks wider than one-half inch or evidence of soil particles entering the structure through the cracks, or maintenance/inspection personnel determine that the vault is not structurally sound.	Vault repaired or replaced so that vaults meets design specifications and is structurally sound.
A	Vault					Structure has Cracks at the Joint of any Inlet/ Outlet Pipe.	Cracks wider than one-half inch at the joint of any inlet/outlet pipe or evidence of soil particles entering through the cracks	Vault repaired so that no cracks exist at the joint of inlet/outlet pipe.
A	Baffles					Baffles	Baffles corroding, cracking, warping, and/or showing signs of failure as determined by maintenance/inspection person.	Baffles repaired or replaced to design specifications.
A	Access Ladder					Ladder Rungs Unsafe	Maintenance person judges that ladder is unsafe due to missing rungs, misalignment, rust, or cracks. Ladder must be fixed or secured immediately.	Ladder meets design standards and allows maintenance persons safe access.

If you are unsure whether a problem exists, please contact a professional engineer.

Comments:

CDS MFS system vault is a confined space. Visual inspections should be performed aboveground. If entry is required it should be performed by qualified personnel.

Default maintenance is annual.

Configuration options include precast or cast in place concrete vaults or precast manhole structures.

Key:

- (M) Monthly from October through April.
- (A) Once in late summer (preferably September).
- (S) After any major storm (use 1 inch in 24 hours as a guideline).

#28 – Maintenance Checklist for Aqua Shield Aqua-Swirl. Also check DOE website and manufacturer guidelines for updates to O&M requirements.

Frequency	Drainage System Feature	Date				Problem	Conditions to Check For	Maintenance Activities and Conditions That Should Exist
		✓	✓	✓	✓			
M	Sediment Storage area					Excessive Sediment Accumulation	Sediment accumulation within 36 inches of water surface	Sediments should be removed.
M	Aqua Swirl Chamber					Trash and Floatable Debris Accumulation	Excessive trash and floatable debris accumulation swirl chamber.	Minimal trash or other floatable debris.
M	Manhole Cover					Cover Damaged/ Not Working	One maintenance person cannot remove lid after applying 80 pounds of lift, corrosion of deformation of cover.	Cover repaired to proper working specifications or replaced.
A	Structure					Vault Structure has Cracks in Wall, Bottom, and Damage to Frame and/or Top Slab.	Cracks wider than one-half inch or evidence of soil particles entering the structure through the cracks, or maintenance/inspection personnel determine that the vault is not structurally sound.	Vault repaired or replaced so that vaults meets design specifications and is structurally sound.
A	Structure					Vault Structure has Cracks at the Joint of any Inlet/ Outlet Pipe.	Cracks wider than one-half inch at the joint of any inlet/outlet pipe or evidence of soil particles entering through the cracks	Vault repaired so that no cracks exist wider than one-fourth inch at the joint of inlet/outlet pipe.
A	Baffles					Baffles	Baffles corroding, cracking, warping, and/or showing signs of failure as determined by maintenance/inspection person.	Baffles repaired or replaced to design specifications.

If you are unsure whether a problem exists, please contact a professional engineer or the manufacturer’s representative.

Comments:

Key:

- (M) Monthly from October through April.
- (A) Once in late summer (preferably September).
- (S) After any major storm (use 1 inch in 24 hours as a guideline).

#29 – Bioretention (Swales and Planters)

Frequency	Drainage System Feature	Date				Problem	Conditions to Check For	Maintenance Activities and Conditions That Should Exist
		✓	✓	✓	✓			
B	Ponding Area					Cracks or Failure in concrete planter reservoir	Cracks wider than ½ inch or maintenance/inspection personnel determine that the vault is not structurally sound	Vault repaired or replaced so that vaults meets design specifications and is structurally sound.
B	Ponding Area					Failure in earthen reservoir (embankments, dikes, berms, and side slopes)	Erosion (gullies/rills) greater than 2 inches around inlets, outlet, and along side slopes.	Eliminate source of erosion and stabilize damaged area (regrade, rock, vegetation, erosion control blanket)
B	Ponding Area					Failure in earthen reservoir embankments, dikes, berms, and side slopes)	Settlement greater than 4 inches (relative to undisturbed sections of berm)	Restore to design height
A	Ponding Area					Failure in earthen reservoir (embankments, dikes, berms, and side slopes)	Downstream face of berm or embankment wet, seeps or leaks evident	Plug holes. Contact geotechnical engineer ASAP.
A	Ponding Area					Failure in earthen reservoir (embankments, dikes, berms, and side slopes)	Any evidence of rodent holes or water piping around holes if facility acts as dam or berm	Eradicate rodents/repair holes (fill and compact)
Q	Ponding Area					Sediment or debris accumulation	Accumulation of sediment or debris	Remove excess sediment or debris. Identify and control the sediment source, if feasible. Facility should be free of material. May contain standing water.
A	Ponding Area					Rockery reservoir or walls	Rock walls are insecure.	Stabilize walls
B	Ponding Area					Basin inlet via surface flow	Soil is exposed or signs of erosion are visible.	Repair and control erosion sources

Frequency	Drainage System Feature	Date				Problem	Conditions to Check For	Maintenance Activities and Conditions That Should Exist
		✓	✓	✓	✓			
B	Ponding Area					Basin inlet via concentrated flow (e.g., curb cuts)	Sediment, vegetation, or debris partially or fully blocking inlet structure.	Clear the blockage. Identify the source of the blockage and take actions to prevent future blockages.
B	Ponding Area					Basin inlet splash block failure	Water splashes adjacent buildings.	Reconfigure/repair blocks
B	Ponding Area					Basin inlet splash block failure	Water disrupts soil media.	Reconfigure/repair blocks
B	Ponding Area					Inlet/outlet pipe failure	Pipe is damaged.	Repair/replace
B	Ponding Area					Inlet/outlet pipe failure	Pipe is clogged.	Remove roots or debris
B	Ponding Area					Outlet pipe/structure failure	Sediment, vegetation, or debris partially or fully blocking inlet structure	Clear the blockage. Identify the source of the blockage and take actions to prevent future blockages.
B	Ponding Area					Trash rack failure	Trash or debris present on trash rack.	Clean and dispose trash
B	Ponding Area					Trash rack failure	Bar screen damaged or missing.	Replace
B	Ponding Area					Check dams and Weirs failures	Sediment, vegetation, or debris partially or fully blocking check dam or weir.	Clear the blockage. Identify the source of the blockage and take actions to prevent future blockages.
B	Ponding Area					Check dams and Weirs failures	Erosion and/or undercutting is present	Repair and take preventative measures to prevent future erosion and/or undercutting
B	Ponding Area					Flow Spreader problems	Sediment blocks 35% or more of ports/notches or, sediment fills 35% or more of sediment trap.	Remove and dispose
B	Ponding Area					Flow Spreader problems	Grade board/baffle damaged or not level.	Remove and reinstall to level position
B	Ponding Area					Overflow/emergency spillway	Overflow spillway is partially or fully plugged with sediment or debris.	Remove/dispose
B	Ponding Area					Overflow/emergency spillway	Native soil is exposed or other signs of erosion damage are present.	Repair erosion and stabilize surface of spillway
B	Ponding Area					Overflow/emergency spillway	Spillway armament is missing.	Replace armament

Frequency	Drainage System Feature	Date				Problem	Conditions to Check For	Maintenance Activities and Conditions That Should Exist
		✓	✓	✓	✓			
B	Ponding Area					Bioretention soil	Water remains in the basin 48 hours or longer after the end of a storm.	Ensure that under drain (if present) is not clogged. If necessary, clear under drain. If this is not the problem, the bioretention soil is likely clogged. Remove upper 2 to 3 inches of soil and replace with imported bioretention soil. Identify sources of clogging and correct.
B	Vegetation					Bottom swale vegetation	Less than 80% of swale bottom is covered with healthy wetland vegetation.	Plant additional vegetation. Ideally, planting should be performed in the fall or winter.
B	Vegetation					Upland slope vegetation	Less than 70% of upland slopes are covered with healthy vegetation.	Plant additional vegetation. Ideally, planting should be performed in the fall or winter.
A	Vegetation					Trees and shrubs	Large trees and shrubs interfere with operation of the basin or access for maintenance.	Prune or remove large trees and shrubs
A	Vegetation					Trees and shrubs	Standing dead vegetation is present.	Remove standing dead vegetation when covering greater than 10% of basin area. Replace dead vegetation annually or immediately if necessary to control erosion (e.g., on a steep slope).
A	Vegetation					Mulch	Bare spots (without much cover) are present or mulch covers less than 3 inches deep for compost or 4 inches deep for course woody mulch.	Replenish mulch to cover bare spots and augment to minimum depth.
As needed	Vegetation					Clippings	Grass or other vegetation clippings accumulate to 2 inches or greater in depth.	Remove clippings
M	Vegetation					Noxious weeds	Listed noxious vegetation is present. See Kitsap County noxious weed list.	By law, noxious weeds must be removed and disposed immediately. It is strongly encouraged that herbicides and pesticides not be used in order to protect water quality.
Q	Vegetation					Weeds	Weeds are present (unless on edge and providing erosion control)	Remove and dispose of weed material. It is strongly encouraged that herbicides and pesticides not be used in order to protect water quality.

Frequency	Drainage System Feature	Date				Problem	Conditions to Check For	Maintenance Activities and Conditions That Should Exist
		✓	✓	✓	✓			
Based on manufacturer instructions	Irrigation					Irrigation system (if any)	Irrigation system present.	Follow manufacturer's instructions for O&M
Weekly (May – September)	Irrigation					Plant watering	Plant establishment period (1-3 years).	Water weekly during periods of no rain to ensure plant establishment
As Needed	Irrigation					Plant watering	Longer term period (3+ years).	Water during drought conditions or more often if necessary to maintain plant cover
Ongoing	Spill Prevention and Response					Spill prevention	Storage or use of potential contaminants in the vicinity of facility.	Exercise spill prevention measures whenever handling or storing potential contaminants
As needed	Spill Prevention and Response					Spill response	Release of pollutants. Call to report any spill to the Washington Dept of Emergency Management 1-800-258-5990	Cleanup spills as soon as possible to prevent contamination of stormwater
At startup	Training and Documentation					Training / written guidance	Training / written guidance is required for proper O&M.	Provide property owners and tenants with proper training and a copy of the O&M manual and Landscape and Maintenance Manual.
A	Safety					Safety (slopes)	Erosion of sides causes slope to exceed 1:4 or otherwise becomes a hazard.	Take actions to eliminate the hazard
A	Safety					Safety (hydraulic structures)	Hydraulic structures (pipes, culverts, vaults, etc.) become a hazard to children playing in and around the facility.	Take actions to eliminate the hazard (such as covering and securing any openings)
A	Safety					Line of sight	Vegetation causes some visibility (line of sight) or driver safety issues.	Prune
A	Aesthetics					Aesthetics	Damage/vandalism/debris accumulation.	Restore facility to original aesthetic conditions
A	Aesthetics					Grass/vegetation	Less than 75% of planted vegetation is healthy with a generally good appearance.	Take appropriate maintenance actions. (e.g., remove/replace plants, amend soil, etc.)
A	Aesthetics					Edging	Grass is starting to encroach on swale.	Repair edging

Frequency	Drainage System Feature	Date				Problem	Conditions to Check For	Maintenance Activities and Conditions That Should Exist
		✓	✓	✓	✓			
B	Pest Control					Mosquitoes	Standing water remains in the basin for more than three days following storms.	Identify the cause of the standing water and take appropriate actions to address the problem (see Bioretention Soil above)
A	Pest Control					Rodents	Rodent holes are present near the facility.	Fill and compact soil around the holes (refer to integrated pest management?)

If you are unsure whether a problem exists, please contact a professional engineer.

Comments:

Key:

- (M) Monthly from November through April.
- (A) Annually, once in late summer (preferable September)
- (S) After any major storm (use 1-inch in 24 hours as a guideline).
- (B) Biannually (spring and fall)
- (Q) Quarterly

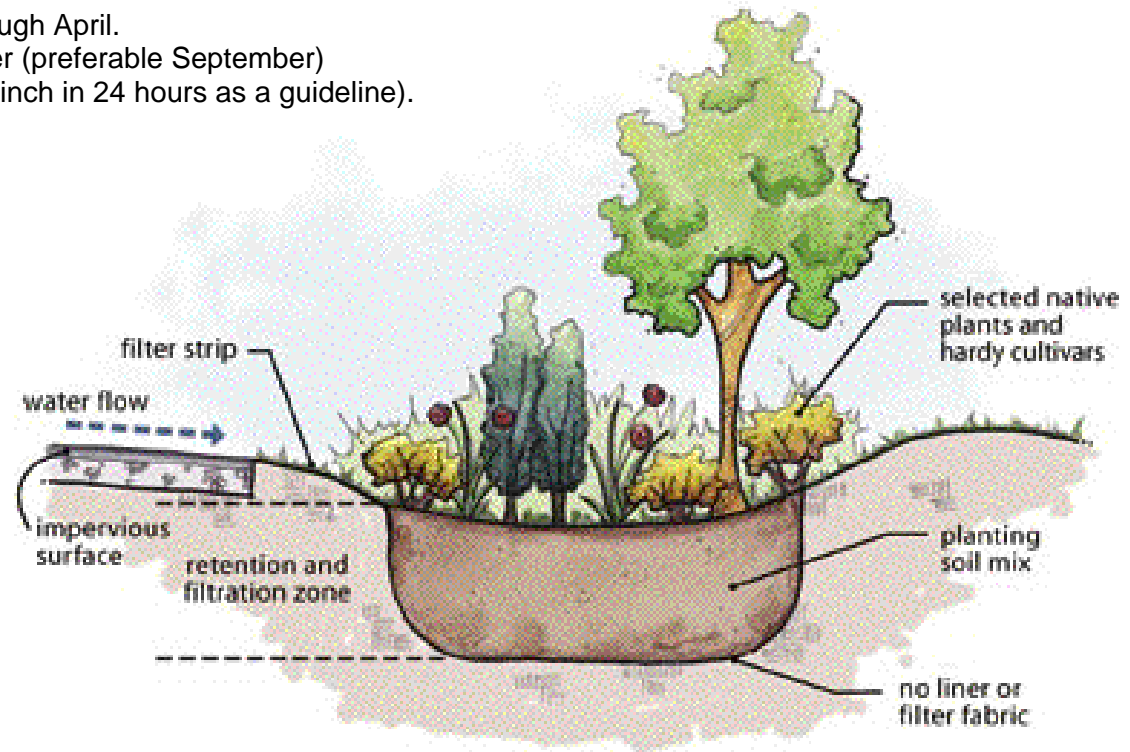

#30 – Cistern

Frequency	Drainage System Feature	Date				Problem	Conditions to Check For	Maintenance Activities and Conditions That Should Exist
		✓	✓	✓	✓			
B	Collection Facilities					Roof	Debris has accumulated.	Remove debris
B	Collection Facilities					Gutter	Debris has accumulated.	Clean gutters (the most critical cleaning is in mid- to late-spring to flush the pollen deposits from surrounding trees)
A	Collection Facilities					Screens at the top of downspout and cistern inlet	Screen has deteriorated.	Replace
M	Collection Facilities					Screens at the top of downspout and cistern inlet	None. Preventative maintenance..	Clear screen of any accumulated debris
M	Collection Facilities					Low flow orifice	None. Preventative maintenance.	Clean low flow orifice
B	Collection Facilities					Overflow pipe	Pipe is damaged.	Repair/replace
B	Collection Facilities					Overflow pipe	Pipe is clogged.	Remove debris
A	Collection Facilities					Cistern	Debris has accumulated at bottom of tank	Remove debris
At startup	Training and Documentation					Training / written guidance	Training / written guidance is required for proper O&M.	Provide property owners and tenants with proper training and a copy of the O&M manual.
Ongoing	Safety					Access and Safety	Access to cistern required for maintenance or cleaning.	Any cistern detention systems opening that could allow the entry of people must be marked: "DANGER—CONFINED SPACE"
B	Pest Control					Mosquitoes	Standing water remains for more than three days following storms.	Ensure cause of standing water is corrected. Also ensure all inlets, overflows, and other openings are protected with mosquito screens.

If you are unsure whether a problem exists, please contact a professional engineer.

Comments:

Key:

- (M) Monthly from November through April.
- (A) Annually, once in late summer (preferable September)
- (S) After any major storm (use 1-inch in 24 hours as a guideline).
- (B) Biannually (spring and fall)
- (Q) Quarterly

#31 – Compost Amended Soil

Frequency	Drainage System Feature	Date				Problem	Conditions to Check For	Maintenance Activities and Conditions That Should Exist
		✓	✓	✓	✓			
A	General Facility Requirements					Soil media (maintain high organic soil content)	Vegetation not fully covering ground surface.	Re-mulch landscape beds with 2-3 inches of mulch until the vegetation fully closes over the ground surface
Ongoing	General Facility Requirements					Soil media (maintain high organic soil content)	None. Preventative maintenance	Return leaf fall and shredded woody materials from the landscape to the site as mulch.
Ongoing	General Facility Requirements					Soil media (maintain high organic soil content)	None. Preventative maintenance	On turf areas, "grasscycle" (mulch-mow or leave the clippings) to build turf health
Ongoing	General Facility Requirements					Soil media (maintain high organic soil content)	None. Preventative maintenance	Avoiding broadcast use of pesticides (bug and weed killers) like "weed & feed," which damage the soil life.
A	General Facility Requirements					Soil media (maintain high organic soil content)	None. Preventative maintenance	Where fertilization is needed (mainly turf and annual flower beds), a moderate fertilization program which relies on natural organic fertilizers (like compost) or slow release synthetic balanced fertilizers.
A	General Facility Requirements					Compaction	Soils become waterlogged, do not appear to be infiltrating.	To remediate, aerate soil, till or further amend soil. If drainage is still slow, consider investigating alternative causes (e.g., high wet-season groundwater levels, low permeability soils). Also consider land use and protection from compacting activities. If areas are turf, aerate compacted areas and top dress them with ¼-½ inch of compost to renovate them.
A	General Facility Requirements					Erosion/scouring	Areas of potential erosion are visible.	Take steps to repair or prevent erosion. Identify and address the causes of erosion.

Frequency	Drainage System Feature	Date				Problem	Conditions to Check For	Maintenance Activities and Conditions That Should Exist
		✓	✓	✓	✓			
A	General Facility Requirements					Grass/vegetation	Less than 75% of planted vegetation is healthy with a generally good appearance.	Take appropriate maintenance actions (e.g., remove/replace plants)
M	General Facility Requirements					Noxious weeds	Listed noxious vegetation is present. See Kitsap County noxious weed list.	By law, noxious weeds must be removed and disposed immediately. It is strongly encouraged that herbicides and pesticides not be used in order to protect water quality.
Q	General Facility Requirements					Weeds	Weeds are present.	Remove and dispose of weed material. It is strongly encouraged that herbicides and pesticides not be used in order to protect water quality.

If you are unsure whether a problem exists, please contact a professional engineer.

Comments:

Key:

- (M) Monthly from November through April.
- (A) Annually, once in late summer (preferable September)
- (S) After any major storm (use 1-inch in 24 hours as a guideline).
- (B) Biannually (spring and fall)
- (Q) Quarterly

#32 – Vegetated Roof

Frequency	Drainage System Feature	Date				Problem	Conditions to Check For	Maintenance Activities and Conditions That Should Exist
		✓	✓	✓	✓			
A	Soil / Growth Medium					Growth medium	Water does not permeate growth media (runs off soil surface).	Aerate or replace media
B	Soil / Growth Medium					Fallen leaves/debris	Fallen leaves or debris are present.	Remove/dispose
A	Soil / Growth Medium					Erosion/scouring	Areas of potential erosion are visible	Take steps to repair or prevent erosion. Stabilize with additional soil substrate/growth medium and additional plants.
A	System Structural Components					General	Structural components are present.	Inspect structural components for deterioration or failure. Repair/replace as necessary.
B	System Structural Components					Inlet pipe	Sediment, vegetation, or debris blocks 35% or more of inlet structure	Clear blockage. Identify and correct any problems that led to blockage.
A	System Structural Components					Inlet pipe	Inlet pipe is in poor conditions	Repair/replace
A	System Structural Components					Inlet pipe	Pipe is clogged.	Remove roots or debris.
B	Vegetation					Coverage	Vegetative coverage falls below 75% (unless design specifications stipulate less than 75% coverage).	Install more vegetation
M	Vegetation					Noxious weeds	Listed noxious vegetation is present. See Kitsap County noxious weed list.	By law, noxious weeds must be removed and disposed immediately. It is strongly encouraged that herbicides and pesticides not be used in order to protect water quality.

Frequency	Drainage System Feature	Date				Problem	Conditions to Check For	Maintenance Activities and Conditions That Should Exist
		✓	✓	✓	✓			
Q	Vegetation					Weeds	Weeds are present	Remove and dispose of weed material. It is strongly encouraged that herbicides and pesticides not be used in order to protect water quality.
A	Vegetation					Plants	Dead vegetation is present.	Remove dead vegetation when covering greater than 10% of basin area. Replace dead vegetation annually or immediately if necessary to control erosion.
Based on manufacturer's instructions	Irrigation					Irrigation system (if any)	Irrigation system present.	Follow manufacturer's instructions for O&M
Weekly (May – September)	Irrigation					Plant watering	Plant establishment period (1-3 years).	Water weekly during periods of no rain to ensure plant establishment
As Needed	Irrigation					Plant watering	Longer term period (3+ years).	Water during drought conditions or more often if necessary to maintain plant cover
Ongoing	Spill Prevention and Response					Spill prevention	Storage or use of potential contaminants in the vicinity of facility.	Exercise spill prevention measures whenever handling or storing potential contaminants
As needed	Spill Prevention and Response					Spill response	Release of pollutants. Call to report any spill to the Washington Dept of Emergency Management 1-800-258-5990	Cleanup spills as soon as possible to prevent contamination of stormwater
At startup	Training and Documentation					Training / written guidance	Training / written guidance is required for proper O&M.	Provide property owners and tenants with proper training and a copy of the O&M manual and Landscape and Maintenance Manual.
A	Safety					Access and Safety	Egress and Ingress routes	Maintain egress and ingress routes to design standards and fire codes
A	Aesthetics					Aesthetics	Damage/vandalism/debris accumulation.	Restore facility to original aesthetic conditions

Frequency	Drainage System Feature	Date				Problem	Conditions to Check For	Maintenance Activities and Conditions That Should Exist
		✓	✓	✓	✓			
A	Aesthetics					Grass/vegetation	Less than 75% of planted vegetation is healthy with a generally good appearance.	Take appropriate maintenance actions. (e.g., remove/replace plants, amend soil, etc.)
B	Pest Control					Mosquitoes	Standing water remains for more than three days following storms.	Remove standing water. Identify the cause of the standing water and take appropriate actions to address the problem (improve drainage).

If you are unsure whether a problem exists, please contact a professional engineer.

Comments:

Key:

- (M) Monthly from November through April.
- (A) Annually, once in late summer (preferable September)
- (S) After any major storm (use 1-inch in 24 hours as a guideline).
- (B) Biannually (spring and fall)
- (Q) Quarterly

#33 – Pervious Pavement

Frequency	Drainage System Feature	Date				Problem	Conditions to Check For	Maintenance Activities and Conditions That Should Exist
		✓	✓	✓	✓			
B	Surface					Pervious asphalt or cement concrete	None. Maintenance to prevent clogging with fine sediment.	Use conventional street sweepers equipped with vacuums, water, and brushes or pressure washer to restore permeability. Vacuum or pressure wash the pavement two to three times annually.
Ongoing	Surface					Pervious asphalt or cement concrete	None. Maintenance to prevent clogging with fine sediment.	Prohibit use of sand and sealant application and protect from construction runoff.
A	Surface					Pervious asphalt or cement concrete	Major cracks or trip hazards.	Fill with patching mixes. Large cracks and settlement may require cutting and replacing the pavement section.
As needed	Surface					Pervious asphalt or cement concrete	Utility cuts.	Any damage or change due to utility cuts must be replaced in kind.
B	Surface					Fallen leaves / debris	Fallen leaves or debris.	Remove/dispose.
B	Surface					Interlocking concrete paver blocks	Interlocking paving block missing or damaged.	Replace damaged paver block.
A	Surface					Interlocking concrete paver blocks	Settlement of surface.	May require resetting
B	Surface					Interlocking concrete paver blocks	Sediment or debris accumulation between paver blocks.	Remove/dispose
A	Surface					Interlocking concrete paver blocks	Loss of void material between paver blocks.	Refill per manufacturer's recommendations.
Varies	Surface					Interlocking concrete paver blocks	Varied conditions.	Perform O&M per manufacturer's recommendations.
B	Surface					Open-celled paving grid with gravel	Sediment or debris accumulation in grid voids.	Remove/dispose

Frequency	Drainage System Feature	Date				Problem	Conditions to Check For	Maintenance Activities and Conditions That Should Exist
		✓	✓	✓	✓			
A	Surface					Open-celled paving grid with gravel	Loss of soil and/or grass material in grid.	Refill and/or replant per manufacturer's recommendations.
Varies	Surface					Open-celled paving grid with gravel	Varied conditions.	Perform O&M per manufacturer's recommendations.
B	Surface					Open-celled paving grid with grass	Sediment or debris accumulation in grid voids.	Remove/dispose
A	Surface					Open-celled paving grid with grass	Loss of soil and/or grass material in grid.	Refill and/or replant per manufacturer's recommendations.
Varies	Surface					Open-celled paving grid with grass	Varied conditions.	Perform O&M per manufacturer's recommendations.
Ongoing	Spill Prevention and Response					Spill prevention	Storage or use of potential contaminants in the vicinity of facility.	Exercise spill prevention measures whenever handling or storing potential contaminants
As needed	Spill Prevention and Response					Spill response	Release of pollutants. Call to report any spill to the Washington Dept of Emergency Management 1-800-258-5990	Cleanup spills as soon as possible to prevent contamination of stormwater.

If you are unsure whether a problem exists, please contact a professional engineer.

Comments:

Key:

- (M) Monthly from November through April.
- (A) Annually, once in late summer (preferable September)
- (S) After any major storm (use 1-inch in 24 hours as a guideline).
- (B) Biannually (spring and fall)
- (Q) Quarterly