



**Issued For Bid**

01-2023

**KITSAP COUNTY**

# SILVERDALE CONVEYANCE SYSTEM AND PUMP STATION 4 UPGRADES SCHEDULES A, B, AND C

**JANUARY 2023**

**LOCATION MAPS**

NTS

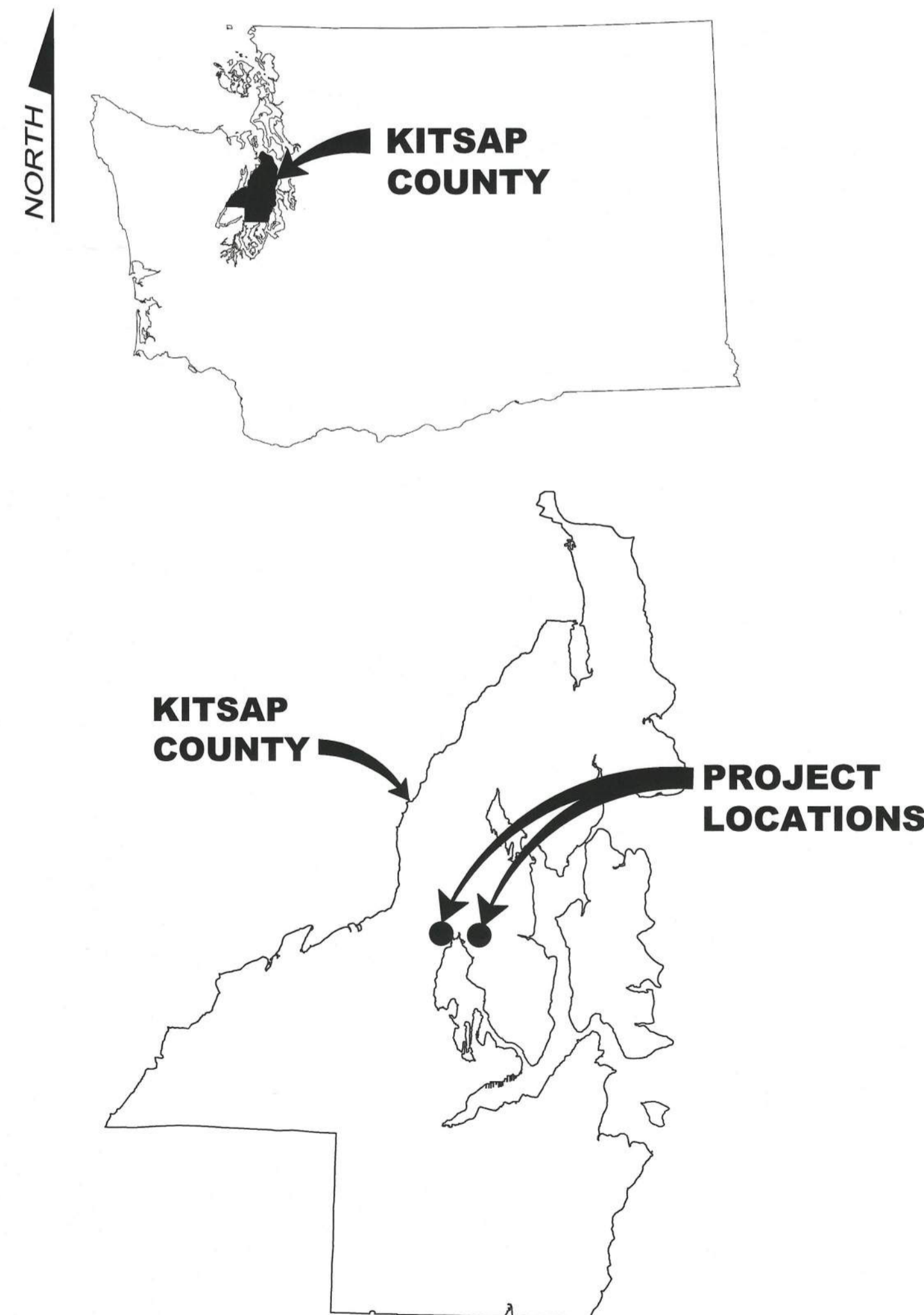

**VICINITY MAP**

NTS

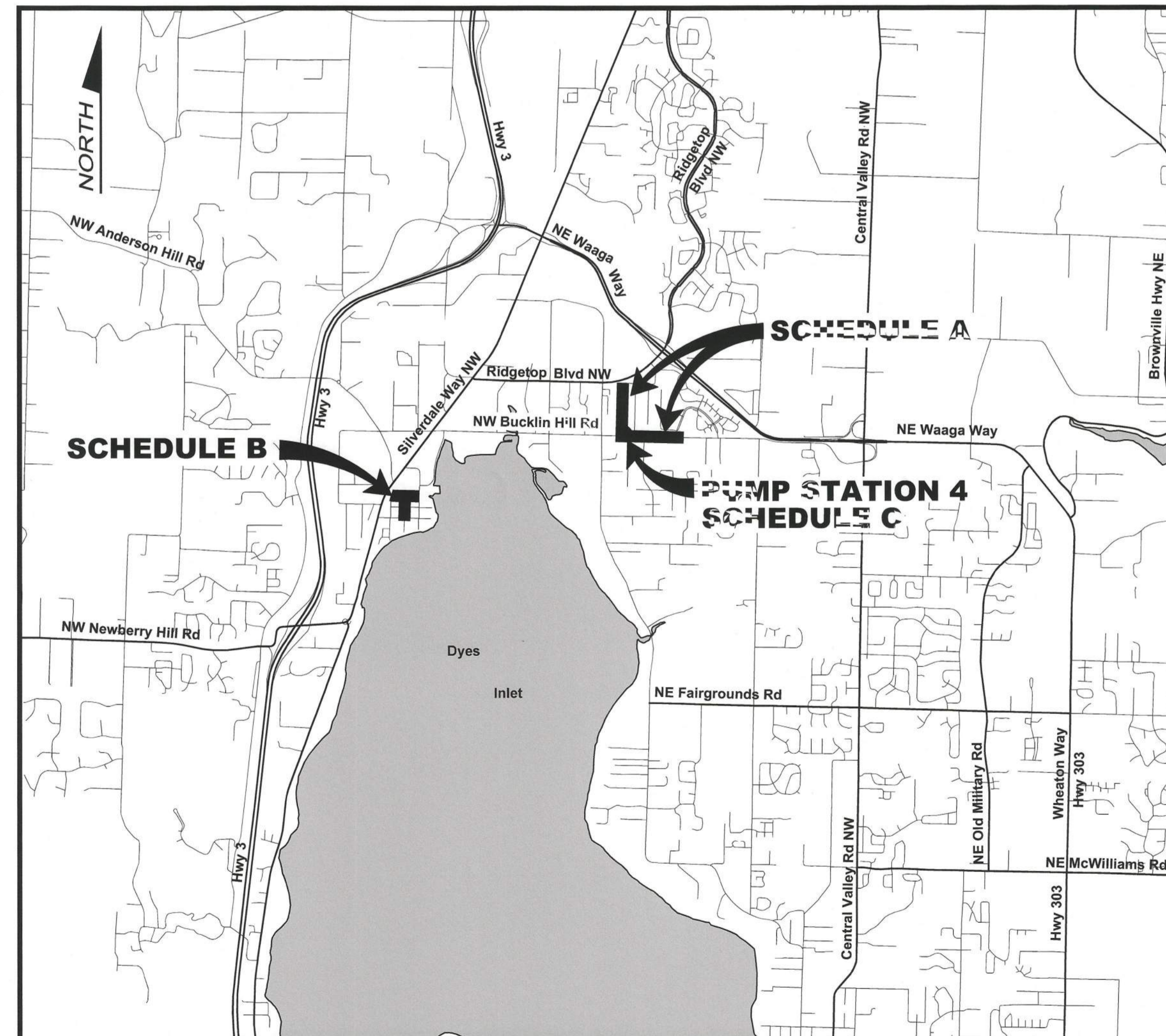

**COUNTY COMMISSIONERS**

- Robert Gelder - District #1
- Charlotte Garrido - District #2
- Katherine Walters - District #3

**APPROVED BY**

1-10-23 DATE  DAVE TUCKER ASST. DIRECTOR OF PUBLIC WORKS

1/9/23 DATE  JOE RUTAN COUNTY ROADS ENGINEER

**PREPARED BY**

**bhc** CONSULTANTS  
**BHC Consultants, LLC**  
 1601 Fifth Avenue, Suite 500  
 Seattle, Washington 98101  
 206.505.3400  
 206.505.3406 (fax)  
 www.bhcconsultants.com

**IN ASSOCIATION WITH**

- Geotechnical & Environmental - Landau Associates, Inc.
- Survey - AES Consulting, Inc.
- HVAC - FSi Engineers
- Traffic - Traffic Engineering Northwest



**LEGEND**

EXISTING	PROPOSED
RIGHT OF WAY	TEMPORARY CONSTRUCTION EASEMENT
CENTERLINE	PROPOSED UTILITY EASEMENT
PROPERTY LINE	CONSTRUCTION LIMIT DELINEATION FENCE
EASEMENT	FILTER FABRIC FENCE
STREAM BUFFER	LIMITS OF CLEARING
BENCHMARK	WETLAND BUFFER BOUNDARY
SURVEY MONUMENT	TO BE REMOVED OR ABANDONED
CONTOUR MAJOR	GEOTEXTILE
CONTOUR MINOR	CHAINLINK FENCE
SPOT ELEVATION	SEWER FACILITY/PIPING
DITCH, STREAM, EDGE OF WATER	SANITARY SEWER MANHOLE OR STRUCTURE
200' SHORELINE JURISDICTION	SANITARY SEWER - GRAVITY
ORDINARY HIGH WATER MARK	SANITARY SEWER - FORCE MAIN
STORM DRAIN	WATER
WATER	ELECTRICAL
SANITARY SEWER - GRAVITY	CLEANOUT
SANITARY SEWER - FORCE MAIN	VALVE BOX
OVERHEAD POWER	CATCH BASIN
BURIED POWER	CONCRETE THRUST BLOCK
OVERHEAD TELEPHONE	FLANGE FITTING
BURIED TELEPHONE	MECHANICAL JOINT FITTING (RESTRAINED FOR ALL PRESSURE PIPE)
BURIED COMMUNICATIONS	FLEXIBLE COUPLING (RESTRAINED FOR ALL PRESSURE PIPE)
BURIED GAS	WIRE TRACER AND HAND HOLE
EDGE OF GRAVEL	CATCH BASIN INSERT
FENCE	SLOPE (PROFILE)
HIGHWAY GUARDRAIL	DIRECTION OF FLOW (PLAN)
BORING	HMA OVERLAY PAVEMENT (PLAN & SECTION)
SANITARY SEWER MANHOLE	HMA TRENCH PATCH
SEWER VALVE BOX	HMA FULL DEPTH REPLACEMENT
CATCH BASIN	GRAVEL SURFACE (PLAN)
STORM MANHOLE	PRECAST CONCRETE
STREET OR YARD LAMP	FOUNDATION MATERIAL
JUNCTION BOX	PIPE BEDDING
UTILITY POLE	CSTC
POLE ANCHOR	CSBC
TELEPHONE PEDESTAL	DRAIN MATERIAL
GAS METER	UNDISTURBED NATIVE
WATER METER AND BOX	TRENCH BACKFILL, SELECT BORROW
WATER VALVE	SAND
FIRE HYDRANT	GROUT
SIGN	CDF
POST	TOP SOIL
MAILBOX	
ROCKERY	
TREE	
HEDGE, BRUSH LINE	
DENSE TREES	
CONCRETE (PLAN)	
GRAVEL SURFACE (PLAN)	
HMA (PLAN)	

**ABBREVIATIONS**

AASHTO	AMERICAN ASSOC. OF STATE HIGHWAY TRANSPORTATION OFFICIALS	JB	JUNCTION BOX
AB	ANCHOR BOLT	JT	JOINT
AC	ASPHALT CONCRETE, ASBESTOS CEMENT	KW	KILOWATT
ACP	ASPHALT CONCRETE PAVEMENT	L	LENGTH OR METAL ANGLE
ADDN	ADDITION, ADDITIONAL	LB	POUND
ADS	POLYETHYLENE PIPE ABOVE FINISHED FLOOR	LF	LINEAR FEET
AFF	ALUMINUM	LT	LEFT
AL	ALUMINUM	MAP	MAPLE
ALD	ALDER	MAX	MAXIMUM
APPROX	APPROXIMATE	MB	MAIL BOX
APWA	AMERICAN PUBLIC WORKS ASSOCIATION	MDD	MAXIMUM DRY DENSITY
ARCH	ARCHITECT, ARCHITECTURAL	MFR	MANUFACTURER
AVE	AVENUE	MH	MANHOLE
AWWA	AMERICAN WATER WORKS ASSOCIATION	MIN	MINIMUM
BLDG	BUILDING	MJ	MECHANICAL JOINT
BC	BURIED CABLE	MON	MONUMENT
BF	BLIND FLANGE	MW	MONITORING WELL
BH	BORE HOLE	N	NORTH, NORTHING
BLT	BOLT	NAD	NORTH AMERICAN DATUM
BM	BENCH MARK, BEAM	NE	NORTHEAST
BMPS	BEST MANAGEMENT PRACTICES	NG	NATURAL GAS
BSP	BLACK STEEL PIPE	NGVD	NATIONAL GEODETIC VERTICAL DATUM
CB	CATCH BASIN, CORNER BAR	NIC	NOT IN CONTRACT
CC	CENTER TO CENTER	NO. OR #	NUMBER
CDF	CONTROLLED DENSITY FILL	NPDES	NATIONAL POLLUTION DISCHARGE ELIMINATION SYSTEM
CF	CLEARING LIMIT FENCE, CUBIC FEET	NPT	NATIONAL PIPE THREAD
CFM	CUBIC FEET PER MINUTE	NPW	NON-POTABLE WATER
CHLK	CHAIN LINK	NTS	NOT TO SCALE
CIP	CAST IN PLACE	NW	NORTHWEST
C/L, CL	CENTERLINE	OC	ON CENTER
CLR	CLEAR, CLEARANCE	OD	OUTSIDE DIAMETER
CMP	CORRUGATED METAL PIPE	OH	OVERHEAD
CMS	CHANGEABLE MESSAGE SIGN	OHW	ORDINARY HIGH WATER
CO	CLEANOUT	OP	OVERHEAD POWER
CONC	CONCRETE	OPNG	OPENING
CONCRT	CONSTRUCTION CONTINUOUS	P	POWER
CONT	CORRUGATED POLYETHYLENE	PE	PLAIN END, POLYETHYLENE
CPE	CORRUGATED POLYETHYLENE PIPE	PG	PERFORMANCE GRADE
CPEP	CORRUGATED POLYETHYLENE PIPE	PK	POINT KNOWN
CPLG	COUPLING	PL	PLATE
CSBC	CRUSHED SURFACING BASE COURSE	PS	PUMP STATION
CSTC	CRUSHED SURFACING TOP COURSE	PSF	POUNDS PER SQUARE FOOT
CULV	CULVERT	PVC	POLYVINYL CHLORIDE
D	DEPTH	PVMT	PAVEMENT
DBH	DIAMETER BREAST HEIGHT	PWR	POWER
DI	DUCTILE IRON	R	RADIUS
DIA OR Ø	DIAMETER	RCP	REINFORCED CONCRETE PIPE
DIP	DUCTILE IRON PIPE	RD	ROAD, ROOF DRAIN
DIPS	DUCTILE IRON PIPE SIZE	RED	REDUCER
DIST	DISTANCE	REINF	REINFORCEMENT
DOE	DEPARTMENT OF ECOLOGY	REQ'D	REQUIRED
DR	DRIVE	RET	RETAINING
DTREE	DECIDUOUS TREE	RFCA	RESTRAINED FLANGED COUPLING ADAPTER
DWG	DRAWING	RJ	RESTRAINED JOINT
E	EAST, EASTING, ELECTRICAL	ROW, R/W	RIGHT OF WAY
EA	EACH	RPBA	REDUCED PRESSURE BACKFLOW ASSEMBLY
EL, ELEV	ELEVATION, ELBOW	RPM	REVOLUTIONS PER MINUTE
ELEC, ELECT	ELECTRICAL	RRC	RED REBAR AND CAP
EOP	EDGE OF PAVEMENT	RT	RIGHT
EQ	EQUAL	S	SOUTH, SLOPE, SEWER
ESC	EROSION AND SEDIMENT CONTROL	SCH	SCHEDULE
ESMT	EASEMENT	SD	STORM DRAIN
EW	EACH WAY	SDMH	STORM DRAIN MANHOLE
EX	EXISTING	SDR	STANDARD DIMENSION RATIO
FF	FINISHED FLOOR	SE	SOUTHEAST
FG	FINISH GRADE	SERV	SERVICE
FL	FLANGE	SF	SILT FENCE, SQUARE FEET
FM	FORCE MAIN	SOC	SPACED ON CENTER
FMCO	FORCE MAIN CLEANOUT	SPEC	SPECIFICATION
FRP	FIBER REINFORCED PLASTIC	SQ	SQUARE
FT	FOOT, FEET	SSFM	SANITARY SEWER FORCE MAIN
G	GAS	SSMH	SEWER MANHOLE
GA	GAUGE	SS	SANITARY SEWER
GALV	GALVANIZED	SST	STAINLESS STEEL
GE	GROOVED END	ST	STREET
GL	GRAVITY LATERAL	STA	STATION
GP	GUARD POST	STD	STANDARD
GPM	GALLONS PER MINUTE	STL	STEEL
GRAV	GRAVEL	STRUCT	STRUCTURAL
GSP	GALVANIZED STEEL PIPE	SW	SOUTHWEST
GV	GATE VALVE	SWPPP	STORMWATER POLLUTION PREVENTION PLAN
HDPE	HIGH DENSITY POLYETHYLENE	T	TELEPHONE
HMA	HOT MIX ASPHALT	T&B	TEMPORARY BENCHMARK
HORIZ OR H	HORIZONTAL	TDH	TOP AND BOTTOM
HP	HIGH POINT, HORSEPOWER	TELJB	TELEPHONE JUNCTION BOX
HT	HUB AND TACK, HEIGHT	TELR	TELEPHONE RISER
HYD	HYDRANT	TESC	TEMPORARY EROSION AND SEDIMENT CONTROL
ID	INSIDE DIAMETER	TOC	TOP OF CONCRETE
IE	INVERT ELEVATION		
IN, OR "	INCH		
IPS	IRON PIPE SIZE		

TOW	TOP OF WALL
TV	TELEVISION (CABLE)
TVR	TELEVISION (CABLE) RISER
TYP	TYPICAL
UGP	UNDERGROUND POWER
UNO	UNLESS NOTED OTHERWISE
VAC	VACUUM
VERT OR V	VERTICAL
W/	WITH
W	WATER, WEST, WIDTH
WM	WATER METER
WSDOT	WASHINGTON STATE DEPARTMENT OF TRANSPORTATION
WS	WATER SERVICE

**DESIGNATIONS**

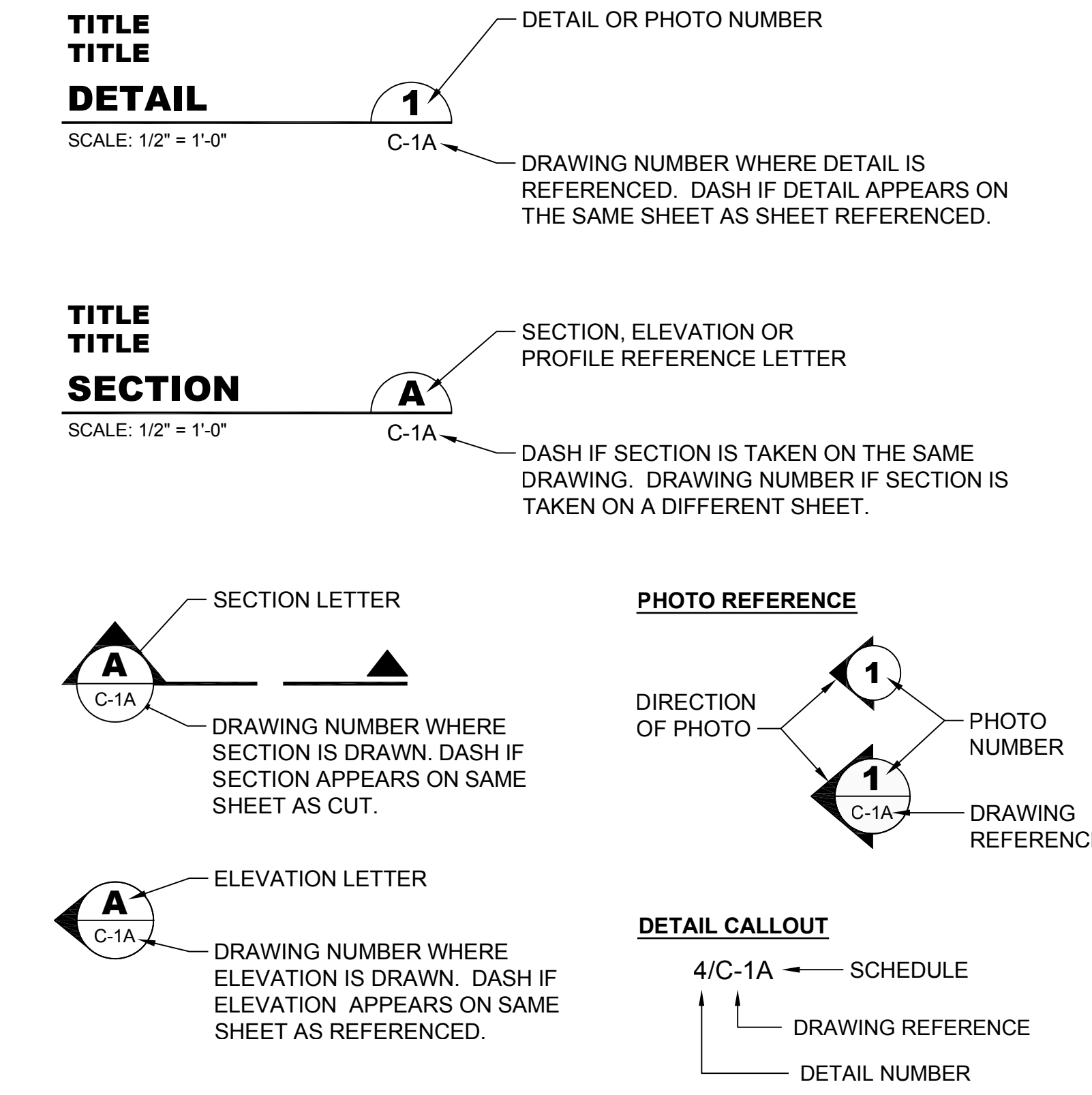

**PIPING DESIGNATIONS**

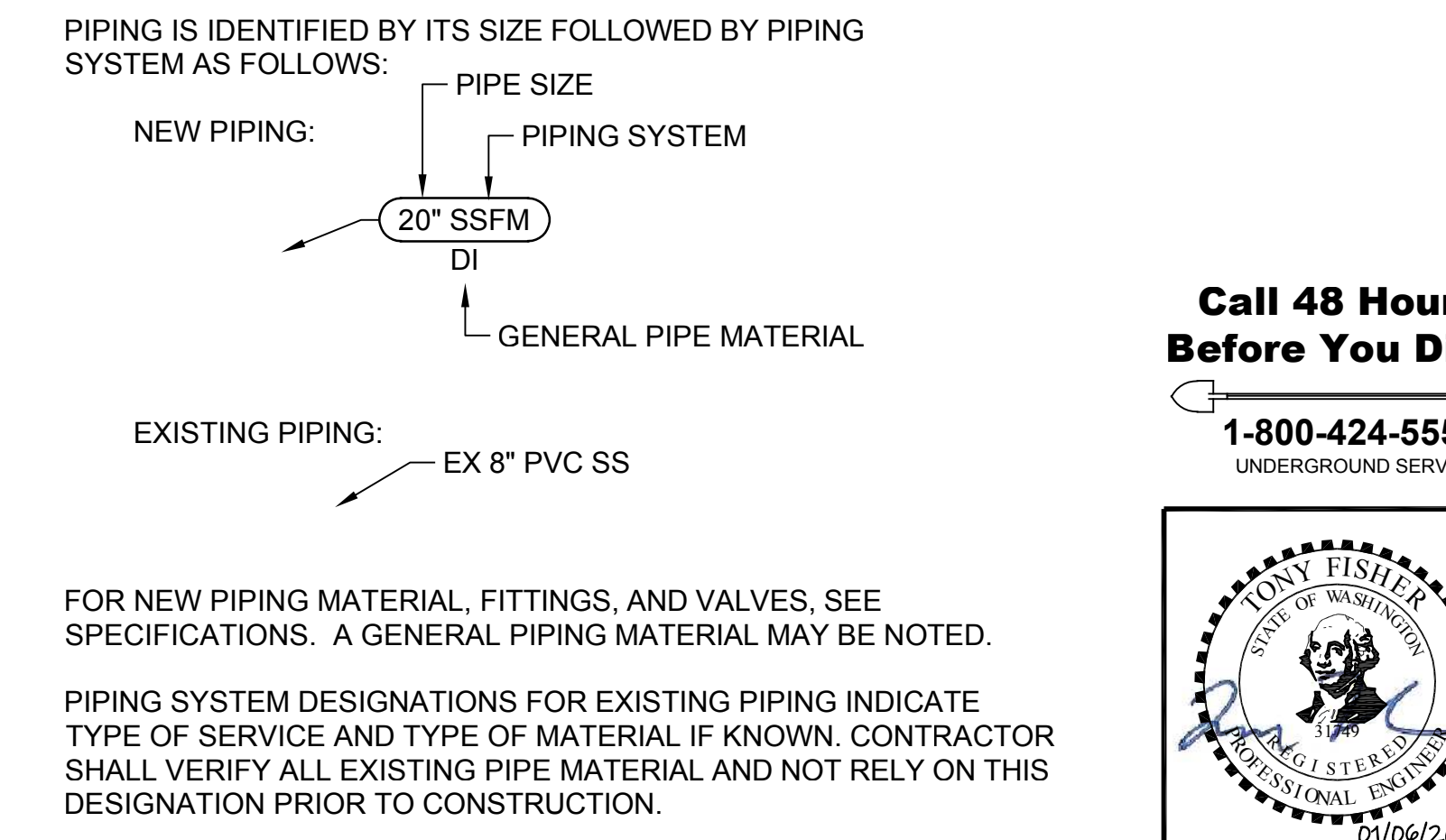

**Call 48 Hours Before You Dig**  
1-800-424-5555  
UNDERGROUND SERVICE

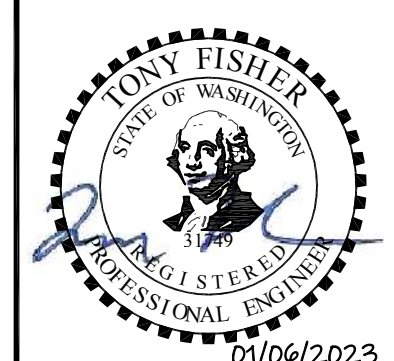

Path: S:\Cadd\Kitsap County\21-10530 Silverdale Conveyance-PS 4 UprgtDesign.dwg File name: P21-10530\_G-3 Plot date: Jan 05, 2023 08:49:24am CAD User: solsoe  
Xref File name: I:\21-10530\_TB\1\Fisher\1\Dan\1\Palmaier\1

No.	Revision	Date	By	App'd
	ISSUED FOR BID	01-2023	TF	RAD

**bhc CONSULTANTS**  
BHC Consultants, LLC  
1601 Fifth Avenue, Suite 500  
Seattle, Washington 98101  
206.505.3400  
206.505.3406 (fax)  
www.bhcconsultants.com

Designed: T. Fisher, P.E.	Scale: N/A
Drawn: P. Simon	One Inch at Full Scale If Not One Inch Scale Accordingly
Checked: R. Dorn, P.E.	

**Kitsap County Public Works**  
614 Division Street, MS 26  
Port Orchard, WA 98366

**SILVERDALE CONVEYANCE SYSTEM AND PUMP STATION 4 UPGRADES**  
**LEGEND, ABBREVIATIONS, AND DESIGNATIONS**

Drawing:	<b>G-3</b>
Sheet:	<b>3</b> of <b>117</b>
File:	P21-10530-PS4_G-3
Date:	January 2023

**GENERAL NOTES**

- ALL WORK AND MATERIALS SHALL BE IN ACCORDANCE WITH THE 2022 EDITION OF THE STANDARD SPECIFICATIONS FOR ROAD, BRIDGE, AND MUNICIPAL CONSTRUCTION (REFERRED TO HEREIN AS THE STANDARD SPECIFICATIONS), PREPARED BY THE WASHINGTON STATE DEPARTMENT OF TRANSPORTATION AND THE WASHINGTON STATE CHAPTER OF THE APWA; KITSAP COUNTY DEPARTMENT OF PUBLIC WORKS STANDARD FOR SANITARY SEWER EXTENSIONS; AND KITSAP COUNTY'S ROAD STANDARDS AND SPECIFICATIONS, AS SUPPLEMENTED BY THE DRAWINGS AND CONTRACT DOCUMENTS.
- CONTRACTOR SHALL VERIFY ALL DIMENSIONS BEFORE STARTING WORK AND IMMEDIATELY NOTIFY THE ENGINEER OF ANY DISCREPANCIES.
- THE CONTRACTOR SHALL EMPLOY THE PROPER STANDARD OF CARE FOR ALL WORK AROUND EXISTING OVERHEAD AND UNDERGROUND UTILITIES. THE CONTRACTOR SHALL BE FULLY RESPONSIBLE FOR THE PROTECTION OF ALL EXISTING UTILITIES AND SHALL VERIFY ALL UTILITY LOCATIONS PRIOR TO CONSTRUCTION BY CALLING THE ONE CALL AT 1-800-424-5555, KITSAP COUNTY PUBLIC WORKS AT (360) 337-5777 AND THE WSDOT, A MINIMUM OF 48 HOURS PRIOR TO ANY EXCAVATION.
- IT SHALL BE THE RESPONSIBILITY OF THE CONTRACTOR TO HAVE A COPY OF THE APPROVED CONSTRUCTION PLANS ON THE CONSTRUCTION SITE AT ALL TIMES.
- ALL PIPING SHALL BE CLEANED AND TESTED PRIOR TO PAVING IN CONFORMANCE WITH THE SPECIFICATIONS.
- PRIOR TO BACKFILL, ALL PIPES AND APPURTENANCES SHALL BE INSPECTED BY THE COUNTY. INSPECTION SHALL NOT RELIEVE THE CONTRACTOR OF CORRECTION OF ANY DEFICIENCIES AND/OR FAILURES AS DETERMINED BY SUBSEQUENT TESTING AND INSPECTION.
- CONTRACTOR SHALL COORDINATE WITH THE COUNTY CONSTRUCTION MANAGER REGARDING TEMPORARY CONSTRUCTION EASEMENTS PRIOR TO CONSTRUCTION ON EASEMENTS.
- CONTRACTOR SHALL DEVELOP A SANITARY SEWER TEMPORARY BYPASS PLAN PRIOR TO DISRUPTING ANY LIVE SEWERS, INCLUDING MAIN LINES, FORCE MAINS, OR SIDE SEWERS. PLAN SHALL ADDRESS COUNTY COORDINATION NEEDS. SUBMIT PLAN TO THE COUNTY CONSTRUCTION MANAGER FOR APPROVAL PRIOR TO CONSTRUCTION.
- PHYSICAL CONNECTIONS TO THE EXISTING SEWER SYSTEM SHALL NOT BE MADE UNTIL AUTHORIZED BY THE COUNTY CONSTRUCTION MANAGER. SUCH AUTHORIZATION WILL NOT BE GIVEN UNTIL THE CONTRACTOR HAS SATISFIED THE COUNTY CONSTRUCTION MANAGER THAT THE NEW GRAVITY SEWER OR FORCE MAIN IS READY TO BE PLACED INTO SERVICE.
- CONTRACTOR SHALL DEVELOP A WATER LINE TEMPORARY BYPASS PLAN PRIOR TO DISRUPTING ANY LIVE WATER LINES, INCLUDING MAIN LINES OR WATER SERVICE LINES. PLAN SHALL ADDRESS WATER PURVEYOR AND PROPERTY OWNER COORDINATION. SUBMIT PLAN TO THE COUNTY CONSTRUCTION MANAGER FOR APPROVAL PRIOR TO CONSTRUCTION.
- CONTRACTOR SHALL BE SOLELY RESPONSIBLE FOR VERIFYING ACCURACY OF ALL UTILITY LOCATIONS SHOWN ON DRAWINGS AND TO FURTHER DISCOVER AND AVOID ALL UTILITIES, SHOWN OR NOT SHOWN, THAT MAY BE IMPACTED BY THE CONTRACTOR'S WORK.
- CONTRACTOR SHALL ADJUST ALL MAINTENANCE HOLE RIMS, DRAINAGE STRUCTURES, LIDS, VALVE BOXES, UTILITY ACCESS STRUCTURES, AND MONUMENT COVERS TO FINISH GRADE WITHIN AREAS AFFECTED BY THE CONTRACTOR'S WORK.
- LIFT STATION 4 SHALL HAVE TWO POWER SOURCES AT ALL TIMES -- UTILITY POWER AND TEMPORARY OR PERMANENT GENERATOR POWER. THE PRIMARY POWER SOURCE AT NIGHT -- 5 PM TO 7 AM -- SHALL BE UTILITY POWER.
- THE OWNER'S TELEMETRY SYSTEM MUST BE OPERATIONAL AT ALL TIMES.
- CONTRACTOR SHALL RE-ESTABLISH ALL DISTURBED SURVEYING MARKERS OR MONUMENTS USING A LICENSED LAND SURVEYOR IN ACCORDANCE WITH THE SPECIFICATIONS AND GOVERNING REGULATIONS.
- NO CONSTRUCTION RELATED ACTIVITY SHALL CONTRIBUTE TO THE DEGRADATION OF THE ENVIRONMENT, ALLOW MATERIAL TO ENTER SURFACE OR GROUND WATERS, OR ALLOW PARTICULATE EMISSIONS TO THE ATMOSPHERE, WHICH EXCEED STATE OR FEDERAL STANDARDS. ANY ACTIONS THAT POTENTIALLY ALLOW A DISCHARGE TO STATE WATERS MUST HAVE PRIOR APPROVAL OF THE WASHINGTON STATE DEPARTMENT OF ECOLOGY.
- CONTRACTOR SHALL BALANCE ALL HVAC SYSTEMS IN ACCORDANCE WITH THE WASHINGTON STATE ENERGY CODE, GENERALLY ACCEPTED ENGINEERING STANDARDS, AND IN ACCORDANCE WITH THE CONTRACT DOCUMENTS.
- PROVIDE CONTROLS IN COMPLIANCE WITH THE WASHINGTON STATE ENERGY CODE, AND THE CONTRACT DOCUMENTS.

**EROSION AND SEDIMENT CONTROL NOTES**

- THE OWNER HAS PREPARED A DRAFT SWPPP. CONTRACTOR MAY MODIFY THE DRAFT SWPPP INCLUDED AS AN APPENDIX TO THE SPECIFICATIONS TO ADDRESS THE CONTRACTOR'S MEANS AND METHODS OR PREPARE A NEW SWPPP AS REQUIRED BY THE PERMIT. THE CONTRACTOR SHALL THEN BE RESPONSIBLE FOR OBTAINING COVERAGE UNDER DOE'S CONSTRUCTION STORMWATER GENERAL PERMIT AND SHALL FOLLOW ALL CONSTRUCTION STORMWATER GENERAL PERMIT REQUIREMENTS.
- DISTURBED AREAS SHALL BE STABILIZED WITH TESC BEST MANAGEMENT PRACTICES. CONTRACTOR SHALL PREVENT EROSION OR SEDIMENT TRANSPORT IN ALL DISTURBED AREAS UNTIL FINAL RESTORATION HAS BEEN ACCOMPLISHED.
- FINAL RESTORATION SHALL NOT LAG MORE THAN 2,000 FEET BEHIND THE FINAL TRENCHING OPERATION OR MORE THAN TWO WEEKS BEYOND SUCCESSFUL TESTING OF THE PIPELINE WITHOUT THE WRITTEN APPROVAL OF THE COUNTY CONSTRUCTION MANAGER.
- CONTRACTOR SHALL BE RESPONSIBLE AT ALL TIMES FOR PREVENTING SILT AND DEBRIS LADEN RUNOFF FROM LEAVING THE PROJECT SITE, ENTERING THE DRAINAGE SYSTEM, OR VIOLATING APPLICABLE WATER QUALITY STANDARDS. FAILURE BY THE CONTRACTOR TO PREVENT SILT OR DEBRIS LADEN RUNOFF OR SEDIMENT FROM BEING TRANSPORTED FROM THE PROJECT SITE MAY RESULT IN A FINE. THE DESIGNATED CONTACT PERSON SHALL BE AVAILABLE BY TELEPHONE ON A 24 HOUR PER DAY BASIS THROUGHOUT CONSTRUCTION AND UNTIL THE PROJECT HAS BEEN COMPLETED AND ACCEPTED BY THE OWNER.
- TESC MEASURES SHOWN ON THE PLANS AND IDENTIFIED IN THE CONTRACTOR'S SWPPP ARE CONSIDERED BASIC REQUIREMENTS FOR THE ANTICIPATED SITE CONDITIONS. DURING CONSTRUCTION, ADDITIONAL PROVISIONS MAY BE NECESSARY TO MAINTAIN WATER QUALITY. MINOR DEPARTURES FROM THE TESC MEASURES SHOWN ON THE PLANS MAY BE PERMITTED SUBJECT TO THE APPROVAL OF THE COUNTY CONSTRUCTION MANAGER. HOWEVER, EXCEPT FOR EMERGENCY SITUATIONS, MAJOR DEVIATIONS MUST BE APPROVED BY THE ENGINEER. DOCUMENTATION AND RECORD KEEPING OF THESE ACTIVITIES SHALL BE IN ACCORDANCE WITH THE CONTRACTOR'S SWPPP.
- TESC MEASURES SHALL BE INSPECTED BY THE CONTRACTOR AS DEFINED IN THE SPECIFICATIONS AND IMMEDIATELY AFTER EACH RAINFALL, AND SHALL BE MAINTAINED AS NECESSARY TO INSURE THEIR CONTINUED FUNCTION. ALL SEDIMENT SHALL BE REMOVED FROM SILT FENCES, STRAW BALES, SEDIMENT PONDS, CATCH BASIN INSERTS, ETC. PRIOR TO THE SEDIMENT REACHING APPROXIMATELY ONE-HALF OF THE MAXIMUM POTENTIAL DEPTH.
- AT NO TIME SHALL CONCRETE, CONCRETE BY-PRODUCTS, VEHICLE FLUIDS, PAINT, CHEMICALS, OR OTHER POLLUTING MATTER BE PERMITTED TO DISCHARGE TO THE TEMPORARY OR PERMANENT DRAINAGE SYSTEM OR TO DISCHARGE FROM THE PROJECT SITE.
- PERMANENT DETENTION/RETENTION PONDS, PIPES, TANKS, OR VAULTS MAY ONLY BE USED FOR SEDIMENT CONTAINMENT WHEN SPECIFICALLY INDICATED ON THESE PLANS OR OTHERWISE APPROVED BY THE OWNER.
- SEDIMENT DEPOSITS REMAINING IN PLACE AFTER THE TESC MEASURES ARE NO LONGER REQUIRED, SHALL BE REMOVED OR DRESSED TO CONFORM TO THE EXISTING GRADE AND SEEDED.
- BARE EARTH AREAS WHERE NO FURTHER WORK IS ANTICIPATED FOR A PERIOD OF 15 DAYS SHALL BE IMMEDIATELY STABILIZED WITH APPROVED TESC MEASURES.
- TESC MEASURES ON INACTIVE SITES SHALL BE INSPECTED AND MAINTAINED AS NECESSARY.
- CONTRACTOR SHALL KEEP ALL PAVED SURFACES IN THE RIGHT OF WAY CLEAN BY SWEEPING.

**CONSTRUCTION SCHEDULE CONSTRAINTS**

- CONTRACTOR SHALL ATTEND A PRECONSTRUCTION CONFERENCE PRIOR TO COMMENCING CONSTRUCTION.
- TEMPORARY EROSION AND SEDIMENT CONTROLS SHALL BE IN PLACE PRIOR TO ANY GROUND DISTRIBUTING ACTIVITIES.
- DURING BYPASS MODE, THE TEMPORARY PUMPING SYSTEM SHALL BE CONNECTED TO THE COUNTY'S TELEMETRY SYSTEM FOR ALL STATION STATUS AND ALARM INDICATIONS. ALARM INDICATIONS SHALL BE AS LISTED IN SECTION 406196 PROGRAMMING WASTEWATER PUMP STATIONS.
- THE NEW SEWER SYSTEM SHALL NOT BE CONNECTED TO THE EXISTING SEWER SYSTEM UNTIL THE NEW SEWER SYSTEM HAS BEEN CLEANED AND SUCCESSFULLY PASSED THE PRESSURE TEST.
- CLOSING ANY LANES OUTSIDE THE NORMAL WORK HOURS OR FOR MORE THAN 12 HOURS REQUIRES THE APPROVAL OF THE KITSAP COUNTY COUNCIL. THE APPROVAL PROCESS MAY TAKE 6 TO 8 WEEKS TO COMPLETE AND APPROVAL IS NOT GUARANTEED. THE CONTRACTING AGENCY SHALL NOT BE RESPONSIBLE FOR ANY DELAYS OR COSTS ASSOCIATED WITH THE CONTRACTOR'S REQUEST TO CLOSE ROADS OR LANES. SEE THE SPECIAL PROVISIONS FOR ADDITIONAL INFORMATION.
- THE CONTRACTOR IS NOTIFIED THAT UPGRADES TO THE COUNTY'S LIFT STATION 4, LOCATED AT THE INTERSECTION OF BUCKLIN HILL ROAD AND FREDRICKSON ROAD NW MAY BE OCCURRING SIMULTANEOUSLY WITH CONSTRUCTION OF THE PIPELINE UPGRADES ALONG THOSE SAME ROADS. THE CONTRACTOR SHALL COORDINATE HIS/HER WORK TO AVOID OR MINIMIZE CONFLICTS WITH THE PUMP STATION CONTRACTOR.
- PUMP STATION MAY BE OPERATED ON GENERATOR POWER ONLY DURING WEEK DAYS FROM 7 AM TO 6 PM. GENERATORS SHALL BE NOISE ATTENUATED TO NOT EXCEED 70 DB AT 23 FEET. UTILITY POWER SHALL BE USED TO OPERATE THE STATIONS AT ALL TIMES OUTSIDE THOSE HOURS UNLESS APPROVED OTHERWISE BY THE COUNTY CONSTRUCTION MANAGER.

**PUMP STATION 4 DESIGN CRITERIA**

PUMP TYPE	SUBMERSIBLE
PUMP MANUFACTURER	FLYGT
FORCE MAIN DIAMETER	20-INCH
NO. OF PUMPS	3 (2-DUTY, 1-STANDBY)
PUMP MODEL	NP 3315 MT 3 ~458
RATED CAPACITY, EACH PUMP	3,665 GPM @ 113' TDH
RATED PUMP SPEED	1,185 RPM
MOTOR HP, EACH PUMP	140 HP
MOTOR SPEED	1,185 RPM
VOLTAGE/PHASES/HERTZ	460/3/60
SPEED CONTROL	VFD
FIRM PUMPING CAPACITY	5,575 GPM @ 127' TDH
STANDBY DIESEL GENERATOR	500 kW (PRE-PURCHASED BY OWNER)

**CONCEPTUAL CONSTRUCTION SEQUENCE**

- INSTALL TESC MEASURES.
- INSTALL NEW SSFM WITHIN BUCKLIN HILL ROAD, INCLUDING THE BYPASS CONNECTION ONSITE.
  - CONNECTIONS TO THE EXISTING SYSTEM SHALL BE MADE BETWEEN 12:30 A.M. AND 5:00 A.M.
  - COUNTY CAN USE TANKER TRUCKS TO BYPASS FLOWS FOR ABOUT 3 TO 4 HOURS DURING THAT TIMEFRAME.
- SETUP TEMPORARY CONTROL SYSTEM (TCS). CONNECT TCS TO EXISTING UTILITY POWER AND USE EXISTING RTU TO TRANSMIT THE FOLLOWING ALARM CONDITIONS.
  - UTILITY POWER LOSS.
  - HIGH WET WELL, LOW WET WELL.
  - PUMP FAIL, GENERATOR FAIL, VFD FAIL.
  - PUMP 1 RUN, PUMP 2 RUN, PUMP 3 RUN.
- RELOCATE EXISTING GENERATOR AND CONNECT TO TCS. NOTE - TWO SOURCE OF POWER SUPPLY TO THE STATION SHALL BE PROVIDED AT ALL TIMES. THIS MAY REQUIRE A TEMPORARY DIESEL PUMP OR DIESEL GENERATOR TO BE MOBILIZED DURING THIS WORK.
- DEMOLISH EXISTING CONTROL BUILDING, EXISTING WET WELL LID, AND EXISTING DRY WELL LID WHILE MAINTAINING UTILITY POWER TO EXISTING PUMPS FROM EXISTING TRANSFORMER.
  - PROVIDE LATERAL SUPPORT FOR WET WELL/DRY WELL WALLS.
  - PROVIDE TEMPORARY SHELTER OVER ALL EXPOSED OPENINGS INTO EXISTING WET WELL/DRY WELL.
- INSTALL TEMPORARY BYPASS PUMPING SYSTEM (TBPS) IN EXISTING WET WELL AND CONNECT TO TCS.
  - AVERAGE FLOWS ~ 1,200 GPM, PEAK FLOWS ~ 2,000 GPM.
  - TWO PUMPS MINIMUM OPERATING WITH VARIABLE FREQUENCY DRIVES.
- REMOVE EXISTING PUMPS, PIPING, AND VALVES FROM DRY WELL. CONSTRUCT NEW WET WELL/DRY WELL AND INSTALL NEW SUBMERSIBLE PUMPS, PIPING, AND VALVES.
- CONSTRUCT CONTROL BUILDING AND INSTALL POWER, CONTROL, AND TELEMETRY PANELS.
- CONSTRUCT ONSITE PIPING.
- INSTALL NEW GENERATOR AND CONNECT TO NEW CONTROL SYSTEM.
- RELOCATE UTILITY POWER POLE, INSTALL NEW TRANSFORMER AND CONNECT TO NEW CONTROL BUILDING PANELS. NOTE - ELECTRICAL UTILITY WORK MAY BE COMPLETED AT ANY TIME PRIOR TO TESTING AND STARTUP AS LONG AS THE NEW UTILITY POWER SERVICE IS FULLY OPERATIONAL PRIOR TO STARTUP AND TESTING OF THE NEW PUMPING SYSTEM.
- SUCCESSFULLY TEST NEW PUMPING SYSTEM USING THE NEW UTILITY POWER SERVICE AND CLEAN WATER.
- DIVERT FLOWS TO NEW WET WELL, TRANSFER OPERATIONS TO NEW PUMPING SYSTEM, AND DISMANTLE TBPS AND TCS.
- REHABILITATE EXISTING WET WELL.
- CONSTRUCT BIOFILTRATION BED, RETAINING WALLS, DRIVEWAYS, AND SIDEWALK IMPROVEMENTS.
- INSTALL PERIMETER FENCING AND COMPLETE ALL RESTORATION.

Path: S:\Cadd\Kitsap County\21-10530 Silverdale Convey-PS 4 Uprgr\Design\Drawings\21-10530\_G-4 Plot.dwg; Jan 05, 2023 08:54:58am CAD User: solace; Xref Filename: I:\21-10530\_TB\1\Fisher\Dan\1\Final.dwg

ISSUED FOR BID	01-2023	TF	RAD
No.	Revision	Date	By App'd

**bhc**  
CONSULTANTS

**BHC Consultants, LLC**  
1601 Fifth Avenue, Suite 500  
Seattle, Washington 98101  
206.505.3400  
206.505.3406 (fax)  
www.bhcconsultants.com

Designed: T. Fisher, P.E.  
Drawn: P. Simon  
Checked: R. Dorn, P.E.

Scale:  
N/A  
One Inch at Full Scale  
If Not One Inch Scale Accordingly



**Kitsap County Public Works**  
614 Division Street, MS 26  
Port Orchard, WA 98366

**SILVERDALE CONVEYANCE SYSTEM AND PUMP STATION 4 UPGRADES**

**NOTES AND DESIGN CRITERIA**

**Call 48 Hours Before You Dig**  
1-800-424-5555  
UNDERGROUND SERVICE

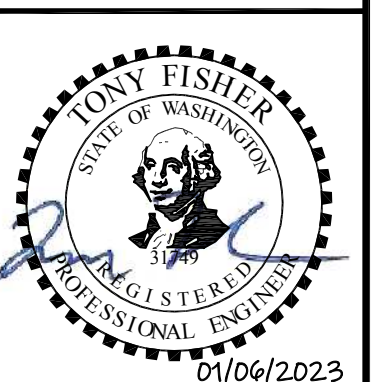

Drawing: **G-4**  
Sheet: **4** of **117**  
File: P21-10530\_G-4  
Date: January 2023

Path: S:\Cadd\Kitsap County\21-10530 Silverdale Conveyance\PS 4 Uprgt\Design\Drawings\G-5 Plot date: Jan 05, 2023 01:50:40pm CAD User: scsae  
 Xref Filename: I\Fisher\1\21-10530-SCU\_Ext\Topo Old Town\1\21-10530\_TB\Drawn\Palmer

NORTH

**SURVEY NOTES**

1. THE LOCATION OF UNDERGROUND UTILITIES SHOWN IS APPROXIMATE ONLY AND HAVE BEEN LOCATED FROM VISIBLE EVIDENCE, AS-BUILT MAPS AND PAINT MARKS BY APPLIED PROFESSIONAL SERVICES, INC. AES CONSULTANTS, INC. MAKES NO GUARANTEE THAT THE UNDERGROUND UTILITIES SHOWN ARE IN THE EXACT LOCATION SHOWN OR COMPRISE ALL SUCH UTILITIES IN THE AREA, EITHER IN SERVICE OR ABANDONED. THE LOCATION OF CRITICAL UNDERGROUND UTILITIES SHOULD BE EXPOSED AND VERIFIED PRIOR TO DESIGN OR CONSTRUCTION. PLEASE NOTIFY ONE CALL AT 1-800-424-5555 AND ARRANGE FOR FIELD LOCATION OF EXISTING FACILITIES BEFORE ANY CONSTRUCTION.
2. SANITARY SEWER MANHOLES WERE NOT ENTERED DURING THIS SURVEY. PIPE SIZES AND MATERIALS WERE OBSERVED FROM THE OUTSIDE OF THE MANHOLE AND ARE ESTIMATED.
3. HORIZONTAL CONTROL DATUM IS WASHINGTON STATE PLAN, NORTH ZONE NAD83(11), US SURVEY FOOT. CONTROL WAS DEVELOPED UTILIZING LEICA GPS RRTK POSITIONING WITH TIES TO WASHINGTON STATE REFERENCE NETWORK. CONTROL WAS DEVELOPED THROUGHOUT THE SITE USING THIS METHOD BY TAKING MULTIPLE OCCUPATIONAL READINGS AND AVERAGING POSITIONS. GROUND TRAVERSE BETWEEN GPS STATIONS WERE PERFORMED FOR CROSS TIES.
4. VERTICAL DATUM IS NAVD 88 PER GPS OBSERVATIONS.
5. IF DISTURBED, REPLACE MONUMENTS AND BENCHMARKS PER WASHINGTON STATE DNR PERMIT TO DESTROY OR REPLACE SURVEY MONUMENTS.

**RIGHT OF WAY CALCULATIONS**

**BUCKLIN HILL ROAD**  
 THE RIGHT OF WAY FOR BUCKLIN HILL ROAD IS CENTERED ON THE SOUTH LINE OF SECTIONS 15 AND 16, TOWNSHIP 25 NORTH, RANGE 1 EAST, W.M. THE CENTERLINE WAS ESTABLISHED BY LOCATING THE SOUTH 1/4 CORNER OF BOTH SECTIONS 15 AND 16 AND THE SECTION CORNER COMMON TO SECTIONS 15, 16, 21 AND 22. THE SECTION CORNER CREATES AN ANGLE POINT IN THE CENTERLINE ALIGNMENT.

**FREDERICKSON ROAD**  
 THE CENTERLINE OF FREDERICKSON ROAD IS CALCULATED BY SUBDIVIDING THE SOUTHEAST QUARTER OF THE SOUTHEAST QUARTER OF SECTION 16, TOWNSHIP 25 NORTH, RANGE 1 EAST, W.M., AND TAKING THE RIGHT OF WAY FROM BOTH SIDES OF THIS SUBDIVISION LINE.

**CARLTONS, LOWELL AND MCCONNELL**  
 THE RIGHT OF WAY FOR THESE STREETS IS BASED ON THE EXISTING CENTERLINE MONUMENTATION WHICH WAS INSTALLED AS PART OF KITSAP COUNTY'S C.R.I.D. NO. 11 PROJECT. REFER TO RECORD OF SURVEY RECORDED IN VOLUME 30, PAGE 195 FOR MONUMENT PLACEMENT.

**SURVEY CONTROL**

PT #	SURVEY PT #	DESCRIPTION	NORTHING	EASTING	ELEVATION
7	38	"MAG" NAIL WITH ID WASHER	243072.24	1186560.11	146.81
8	40	"MAG" NAIL WITH ID WASHER	242752.87	1186549.02	135.23
9	41	CAP ON REBAR	242677.42	1186559.46	133.88
10	42	"MAG" NAIL WITH ID WASHER	243664.06	1186592.98	156.70
11	45	RED ID CAP ON REBAR	242703.90	1187393.79	191.55
12	46	RED ID CAP ON REBAR	242642.91	1187998.17	223.38
13	53	RED ID CAP ON REBAR	241193.09	1180830.89	35.40
14	54	RED ID CAP ON REBAR	241241.73	1181159.07	29.66
15	55	RED ID CAP ON REBAR	241231.56	1181416.70	21.01
16	60	"MAG" NAIL WITH ID WASHER	240441.50	1181261.50	13.86
17	61	"MAG" NAIL WITH ID WASHER	240617.10	1181378.76	15.28
18	3306	"MAG" NAIL WITH ID WASHER	240564.88	1181116.16	14.12

NORTH

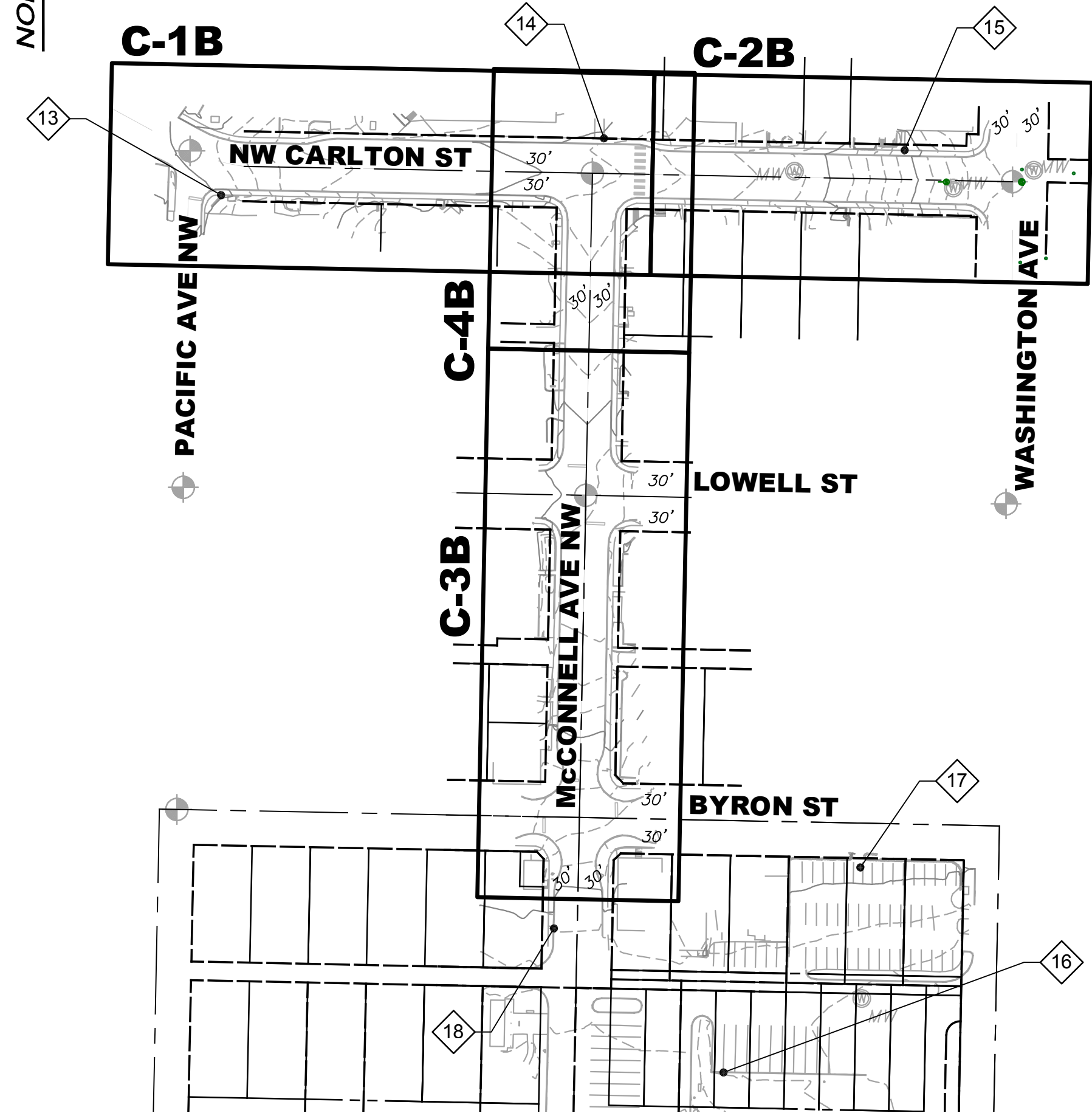

**DRAWING/SCHEDULE INDEX**

DRAWING NO.	SCHEDULE
C-#A	A
C-#B	B
C-#C	C

**Call 48 Hours Before You Dig**

**1-800-424-5555**  
 UNDERGROUND SERVICE

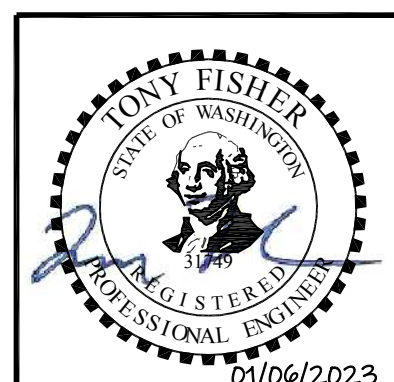

Drawing: **G-5**  
 Sheet: **5** of **117**  
 File: P21-10530\_G-5  
 Date: January 2023

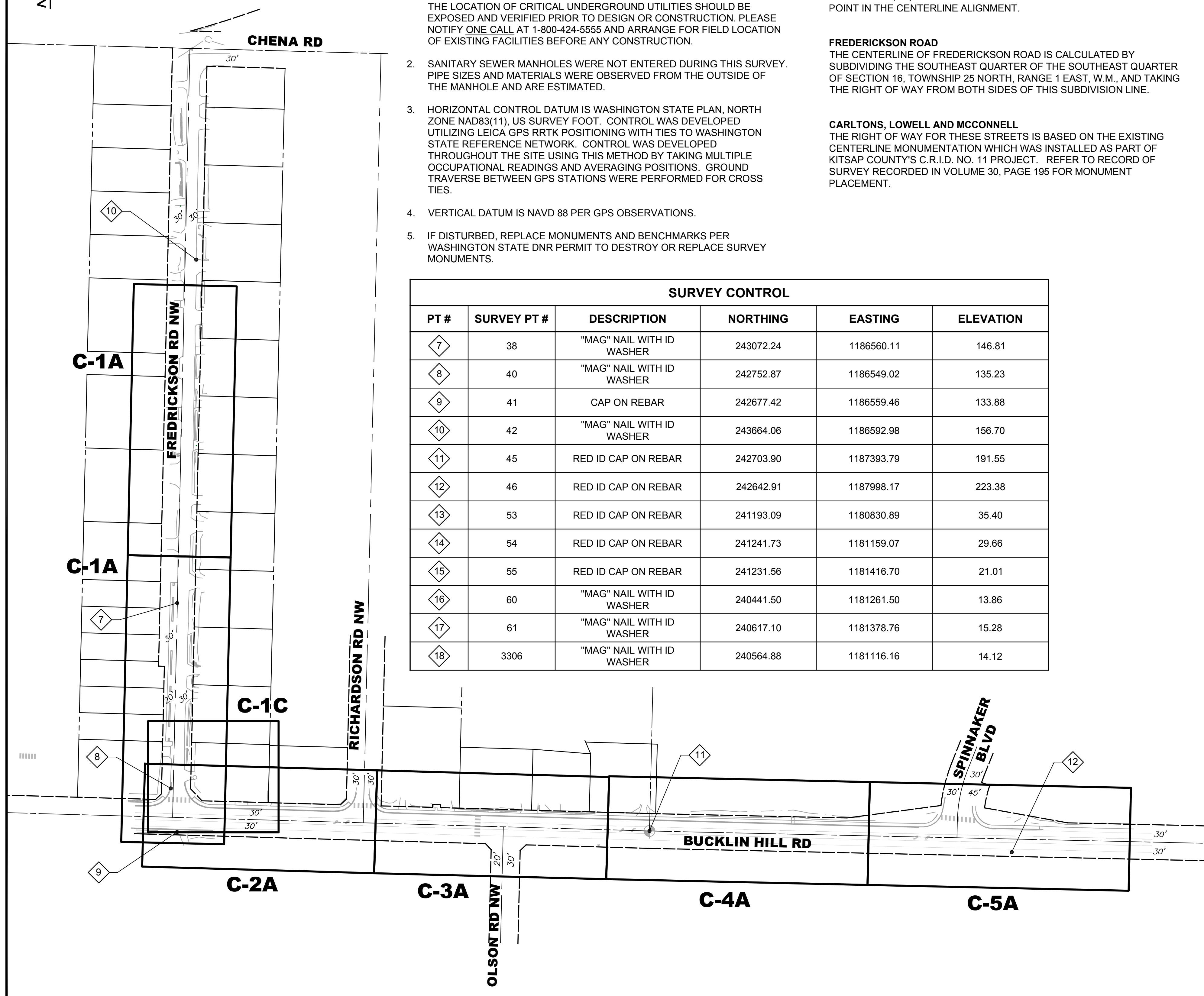

**BHC Consultants, LLC**  
 1601 Fifth Avenue, Suite 500  
 Seattle, Washington 98101  
 206.505.3400  
 206.505.3406 (fax)  
 www.bhcconsultants.com

Designed: T. Fisher, P.E.  
 Drawn: P. Simon  
 Checked: R. Dorn, P.E.

Scale:  
 As Shown  
 One Inch at Full Scale  
 If Not One Inch Scale Accordingly



**Kitsap County Public Works**  
 614 Division Street, MS 26  
 Port Orchard, WA 98366

**SILVERDALE CONVEYANCE SYSTEM AND PUMP STATION 4 UPGRADES**

**OVERALL KEY MAPS AND SURVEY CONTROL**

No.	Revision	Date	By	App'd
	ISSUED FOR BID	01-2023	TF	RAD

Path: S:\Cadd\Kitsap County\21-10530 Silverdale Conveyance-PS 4 UprgtDesign.d File Name: P21-10530\_C-1 Plot Date: Jan 06, 2023 02:00:30pm CAD User: solisee  
 Xref File Name: 1\21-10530\_TB | Fisher | Dan | Palmieri |

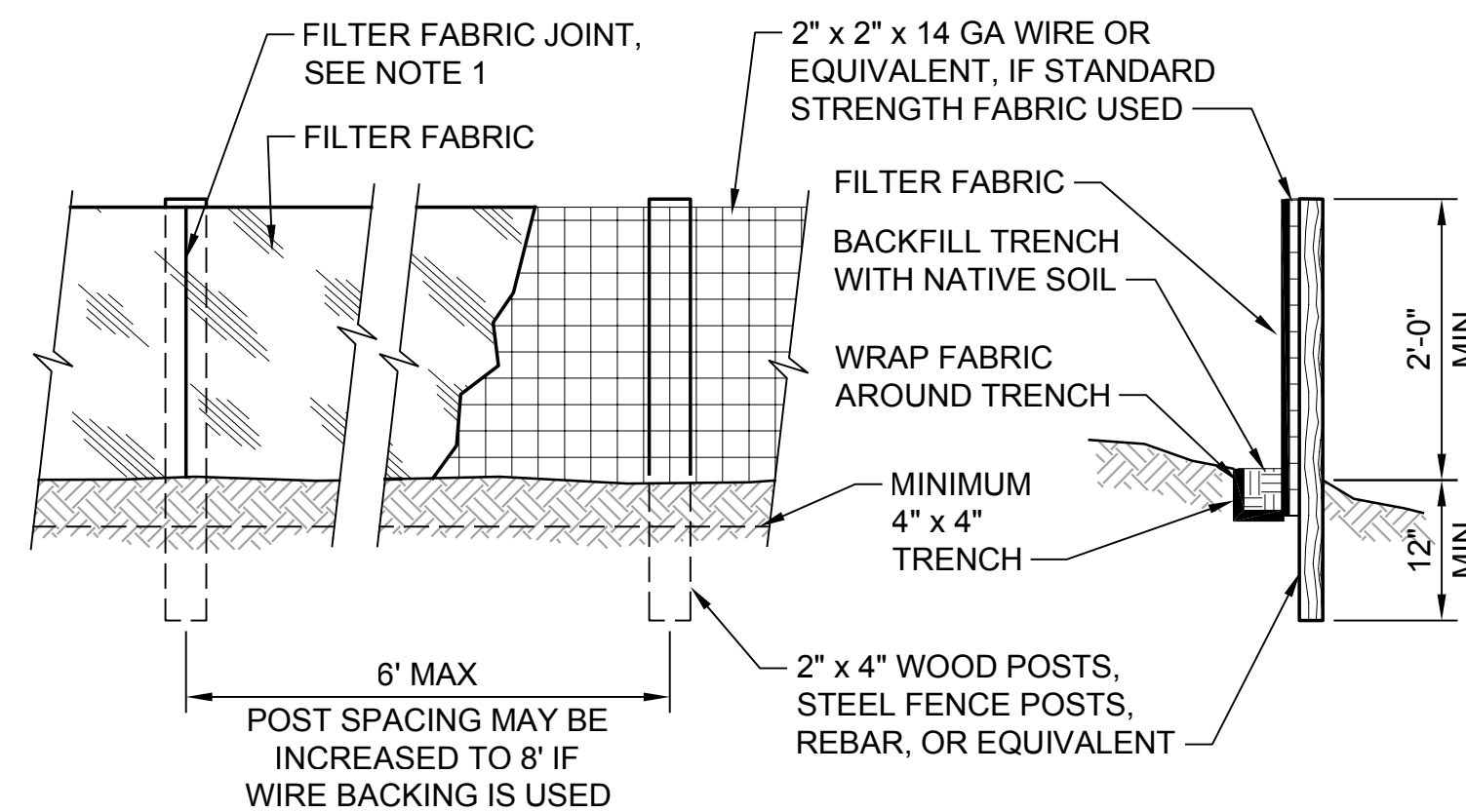

- NOTES:**
1. FILTER FABRIC FENCES SHALL BE INSTALLED ALONG CONTOUR WHENEVER POSSIBLE. JOINTS IN FILTER FABRIC SHALL BE SPLICED AT POSTS. USE STAPLES, WIRE RINGS, OR EQUIVALENT TO ATTACH FABRIC TO POSTS. INSTALL FILTER FABRIC ACCORDING TO THE MANUFACTURER'S SPECIFICATIONS.
  2. FILTER FABRIC FENCE TO BE USED WHERE NEEDED IN ACCORDANCE WITH THE CONTRACT DOCUMENTS.

**FILTER FABRIC FENCE  
DETAIL**

NTS TYP **1**

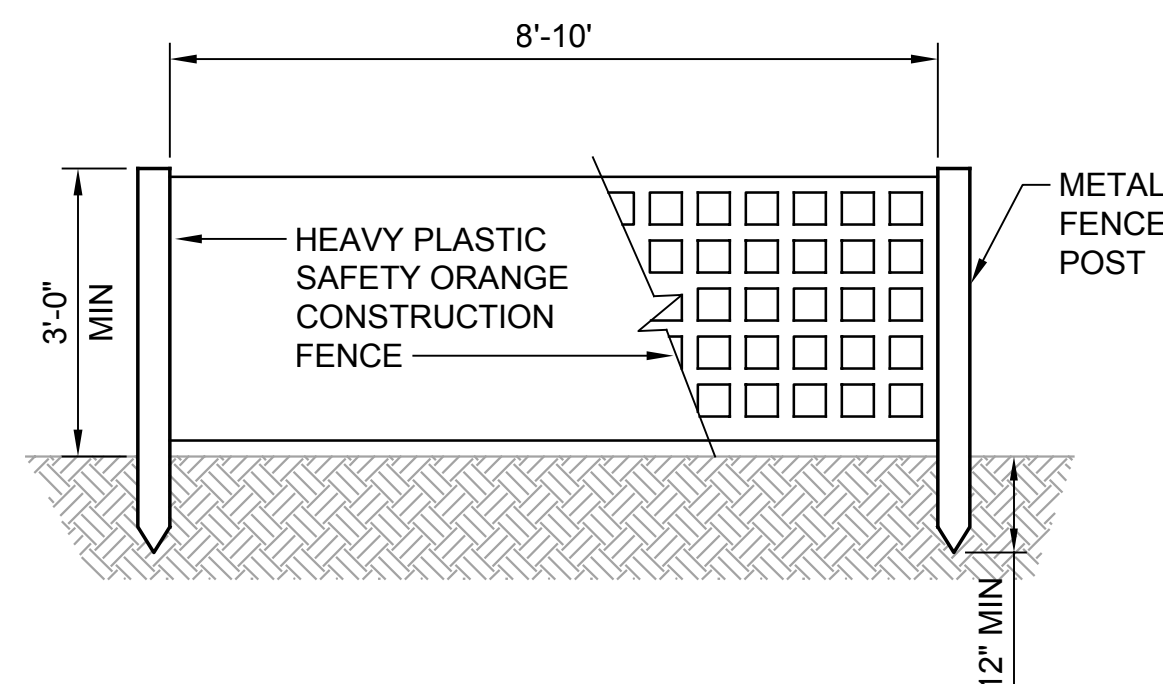

- NOTE:**
- FENCE TO BE USED WHERE CONSTRUCTION OR REMEDIATION ACTIVITIES ARE ONGOING AND SHALL BE INSTALLED ALONG THE PROJECT CLEARING LIMITS TO DELINEATE WORK ZONE.

**CLEARING LIMIT/WORK ZONE  
DELINEATION FENCE  
DETAIL**

NTS TYP **2**

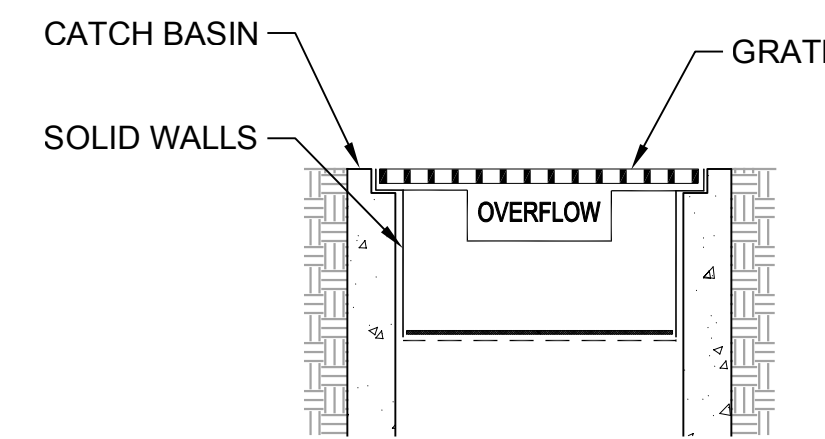

- NOTE:**
- THIS DETAIL IS ONLY SCHEMATIC. ANY INSERT IS ALLOWED THAT HAS A MINIMUM 0.5 CF OF STORAGE, THE MEANS TO DEWATER THE STORED SEDIMENT, HAS AN OVERFLOW, AND CAN BE EASILY MAINTAINED.

**CATCH BASIN INSERT  
DETAIL**

NTS TYP **3**

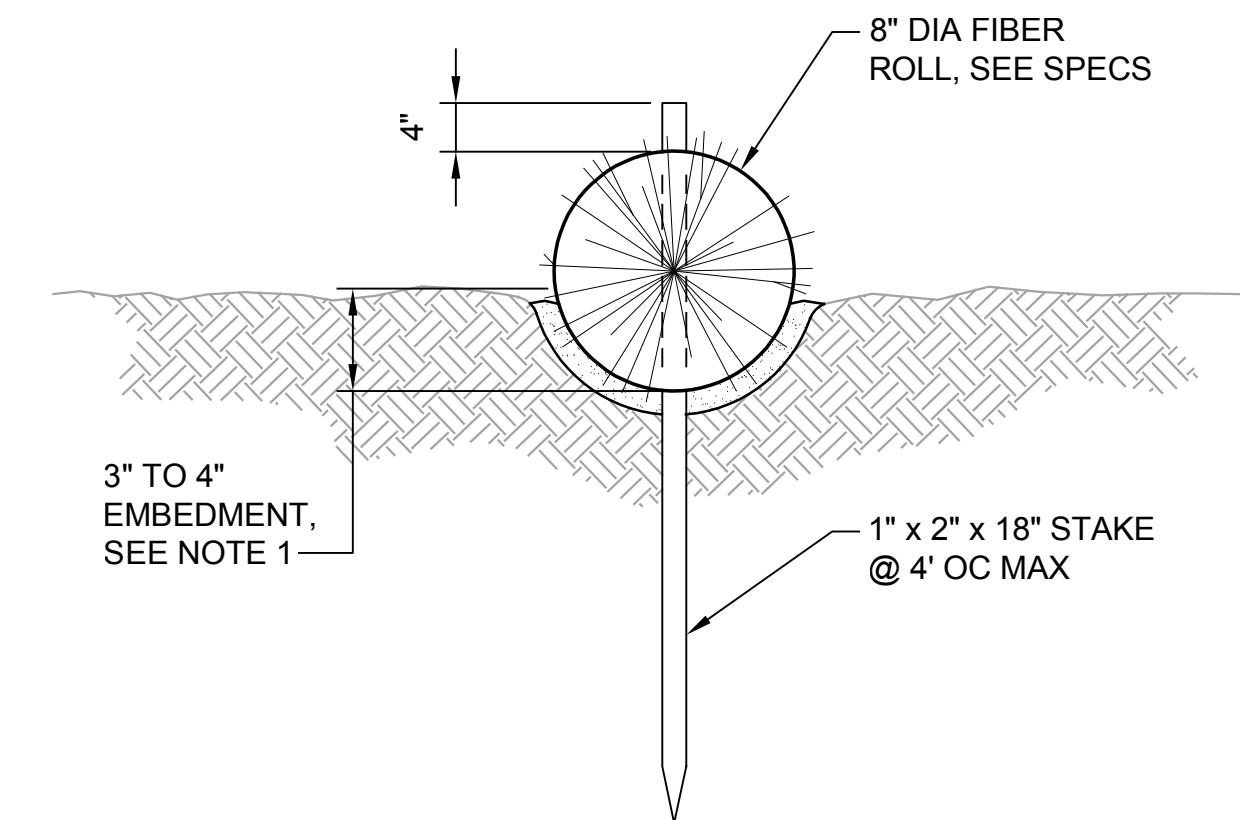

- NOTES:**
1. DISPOSE OF USED FIBER ROLLS OFFSITE.

**FIBER ROLL  
DETAIL**

NTS TYP **4**

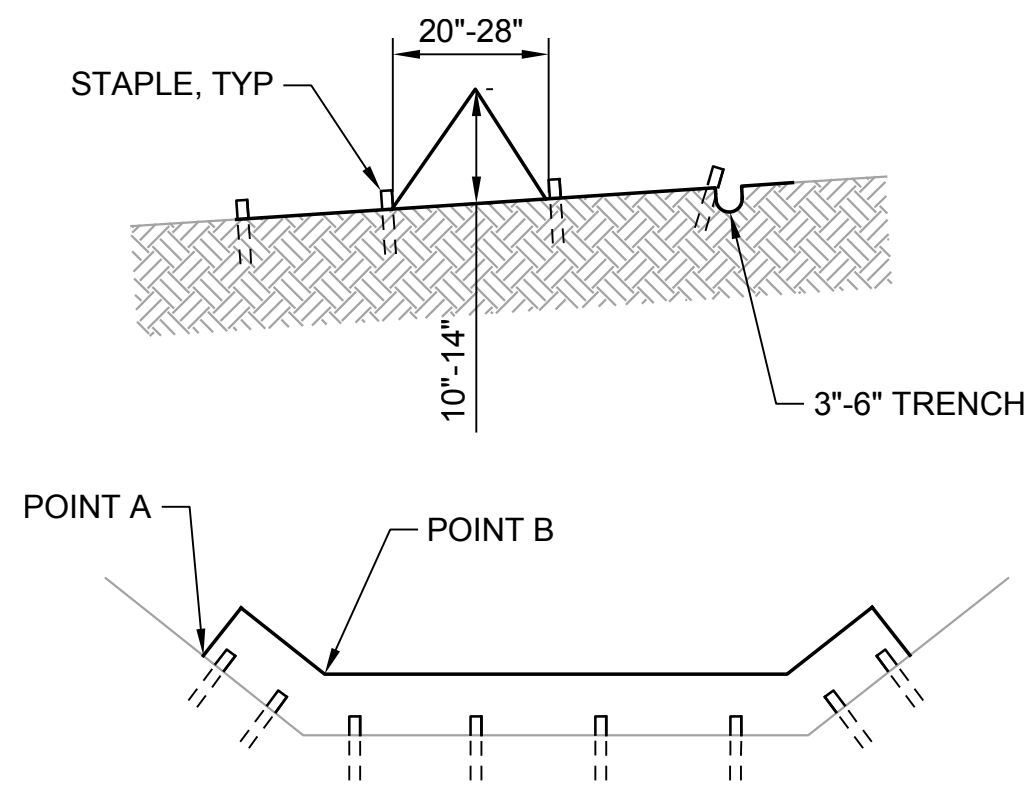

- NOTES:**
1. TRIANGULAR SILT DIKE SHALL BE URETHANE FOAM SEWN INTO A WOVEN GEOSYNTHETIC FABRIC.
  2. A 2' MINIMUM APRON SHALL EXTEND ON EITHER SIDE OF THE TRIANGULAR SECTION.
  3. STAPLES SHALL BE NO. 11 GAUGE WIRE, 8"-12" IN LENGTH, INSTALLED 3' ON CENTER AND WHERE DIKE UNITS OVERLAP.
  4. THE LEADING EDGE SHALL BE SECURED WITH SANDBAGS OR KEYED INTO NATIVE GROUND.
  5. SEDIMENT SHALL BE REMOVED WHEN IT REACHES ONE HALF THE HEIGHT OF THE DAM.
  6. POINT A SHALL BE HIGHER THAN POINT B.

**SILT DIKE  
DETAIL**

NTS TYP **5**

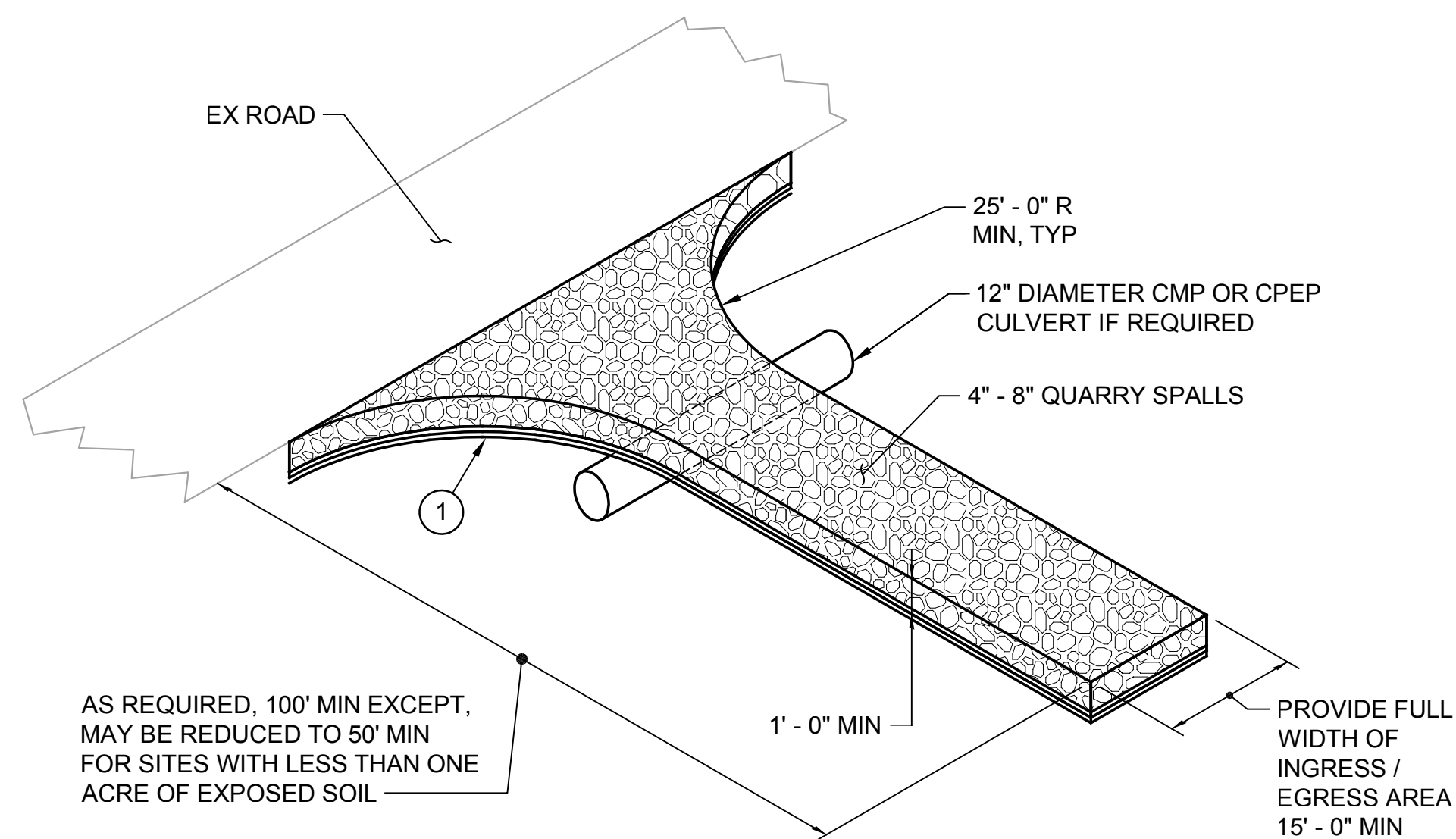

AS REQUIRED, 100' MIN EXCEPT, MAY BE REDUCED TO 50' MIN FOR SITES WITH LESS THAN ONE ACRE OF EXPOSED SOIL

- 1** PLACE CONSTRUCTION GEOTEXTILE FOR SOIL STABILIZATION AND A MINIMUM OF 0.15' CRUSHED ROCK UNDER THE SPALLS FOR THE FULL LENGTH AND WIDTH OF THE ENTRANCE.

**ISOMETRIC VIEW**

**STABILIZED CONSTRUCTION  
ENTRANCE  
DETAIL**

NTS TYP **6**

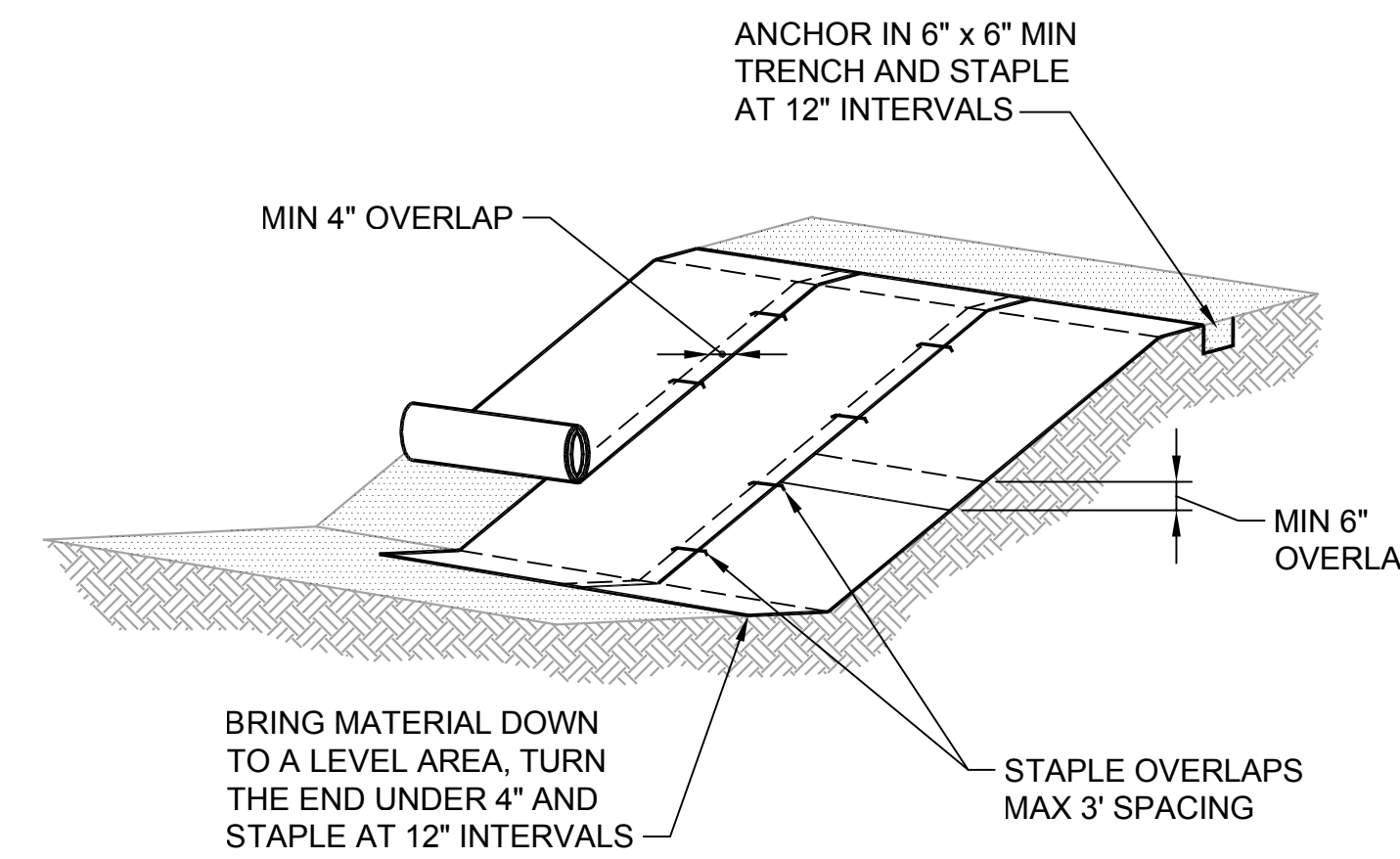

- NOTES:**
1. SLOPE SURFACE SHALL BE SMOOTH BEFORE PLACEMENT FOR PROPER SOIL CONTACT.
  2. STAPLING PATTERN AS PER MANUFACTURER'S RECOMMENDATIONS.
  3. DO NOT STRETCH BLANKETS/MATTINGS TIGHT - ALLOW THE ROLLS TO MOLD TO ANY IRREGULARITIES.
  4. FOR SLOPE LESS THAN 3H:1V, ROLLS MAY BE PLACED IN HORIZONTAL STRIPS.
  5. IF THERE IS A BERM AT THE TOP OF SLOPE, ANCHOR UPSLOPE OF THE BERM.
  6. LIME, FERTILIZE AND SEED BEFORE INSTALLATION. PLANTING OF SHRUBS, TREES, ETC. SHOULD OCCUR AFTER INSTALLATION.
  7. EROSION CONTROL BLANKETS SHALL BE BIODEGRADABLE.

**EROSION CONTROL  
BLANKET  
DETAIL**

NTS TYP **7**

**Call 48 Hours  
Before You Dig**

**1-800-424-5555**  
UNDERGROUND SERVICE



**BHC Consultants, LLC**  
1601 Fifth Avenue, Suite 500  
Seattle, Washington 98101  
206.505.3400  
206.505.3406 (fax)  
www.bhcconsultants.com

Designed: T. Fisher, P.E.  
Drawn: P. Simon  
Checked: R. Dorn, P.E.

Scale:  
NTS  
One Inch at Full Scale  
If Not One Inch  
Scale Accordingly



**Kitsap County Public Works**  
614 Division Street, MS 26  
Port Orchard, WA 98366

**SILVERDALE CONVEYANCE SYSTEM AND PUMP STATION 4 UPGRADES**

**EROSION CONTROL  
DETAILS AND NOTES**

Drawing: **C-1**  
Sheet: **6** of **117**  
File: P21-10530\_C-1  
Date: January 2023

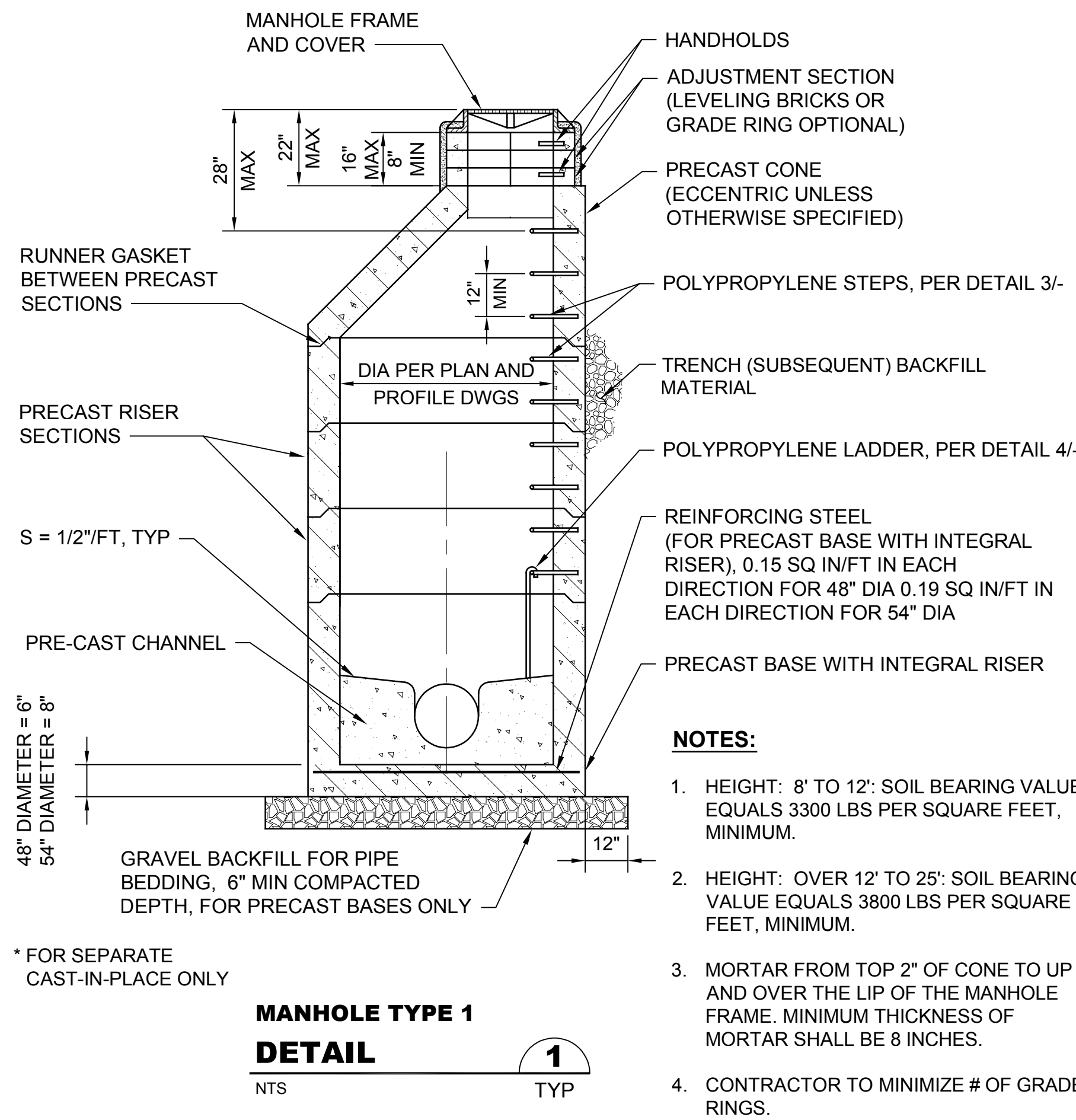

**MANHOLE TYPE 1  
DETAIL**  
NTS TYP

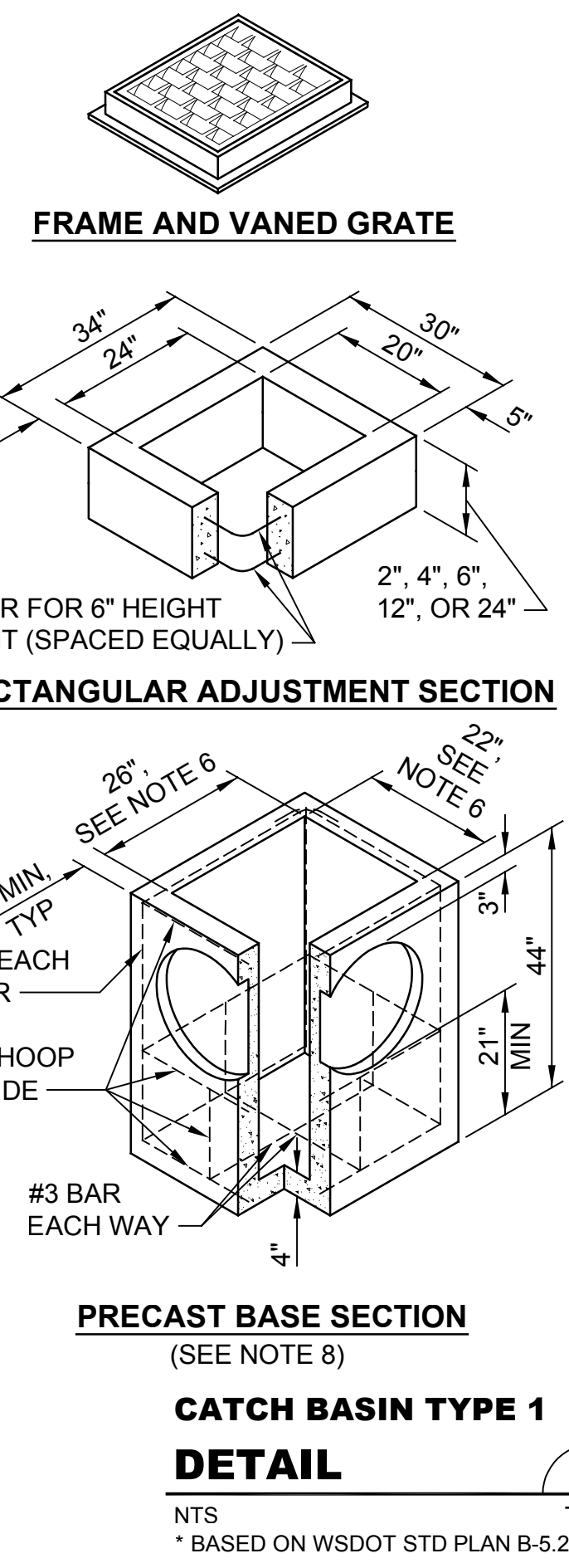

**RECTANGULAR ADJUSTMENT SECTION**  
**PRECAST BASE SECTION**  
(SEE NOTE 8)  
**CATCH BASIN TYPE 1  
DETAIL**  
NTS TYP  
\* BASED ON WSDOT STD PLAN B-5.20-01

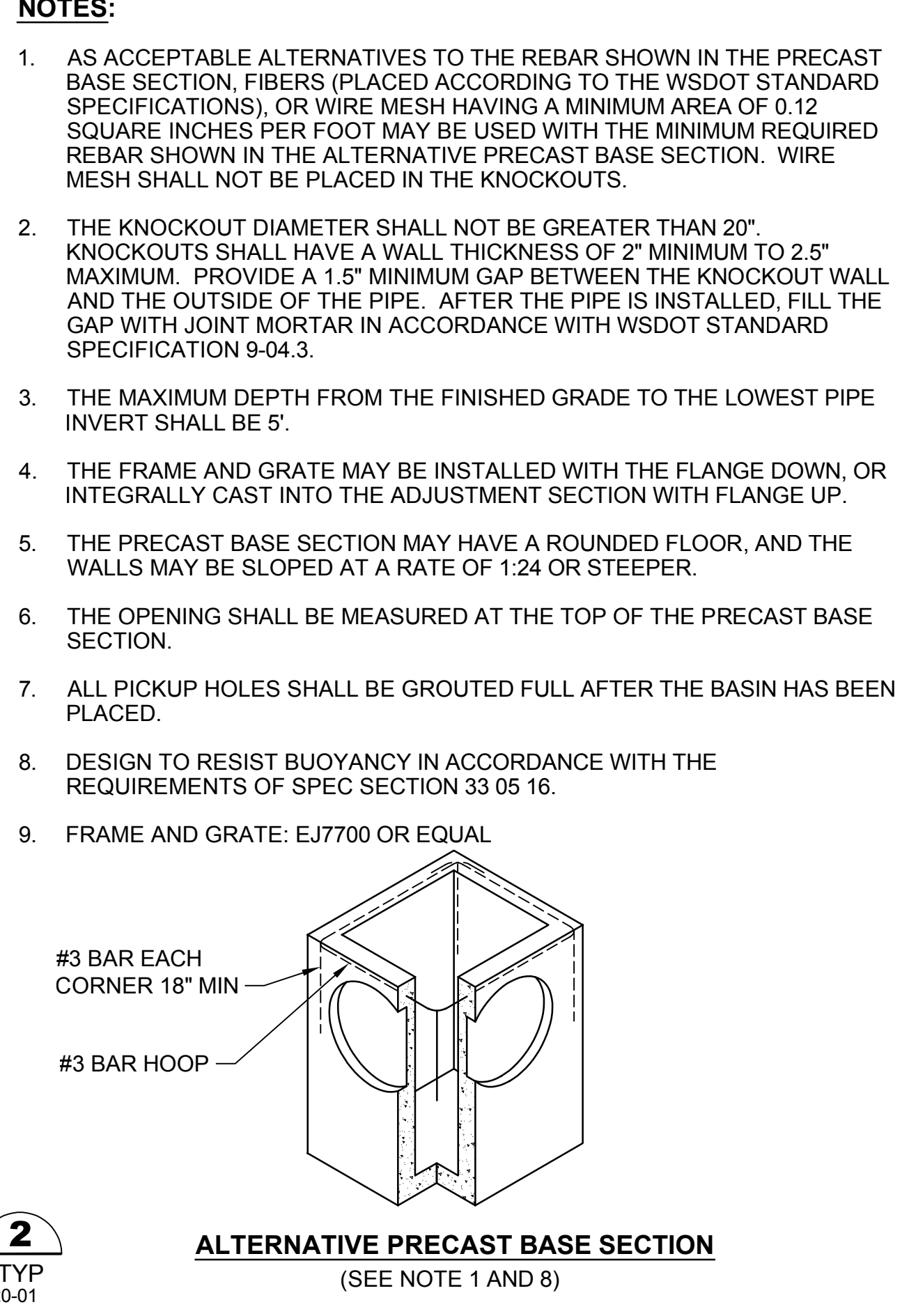

**ALTERNATIVE PRECAST BASE SECTION**  
(SEE NOTE 1 AND 8)

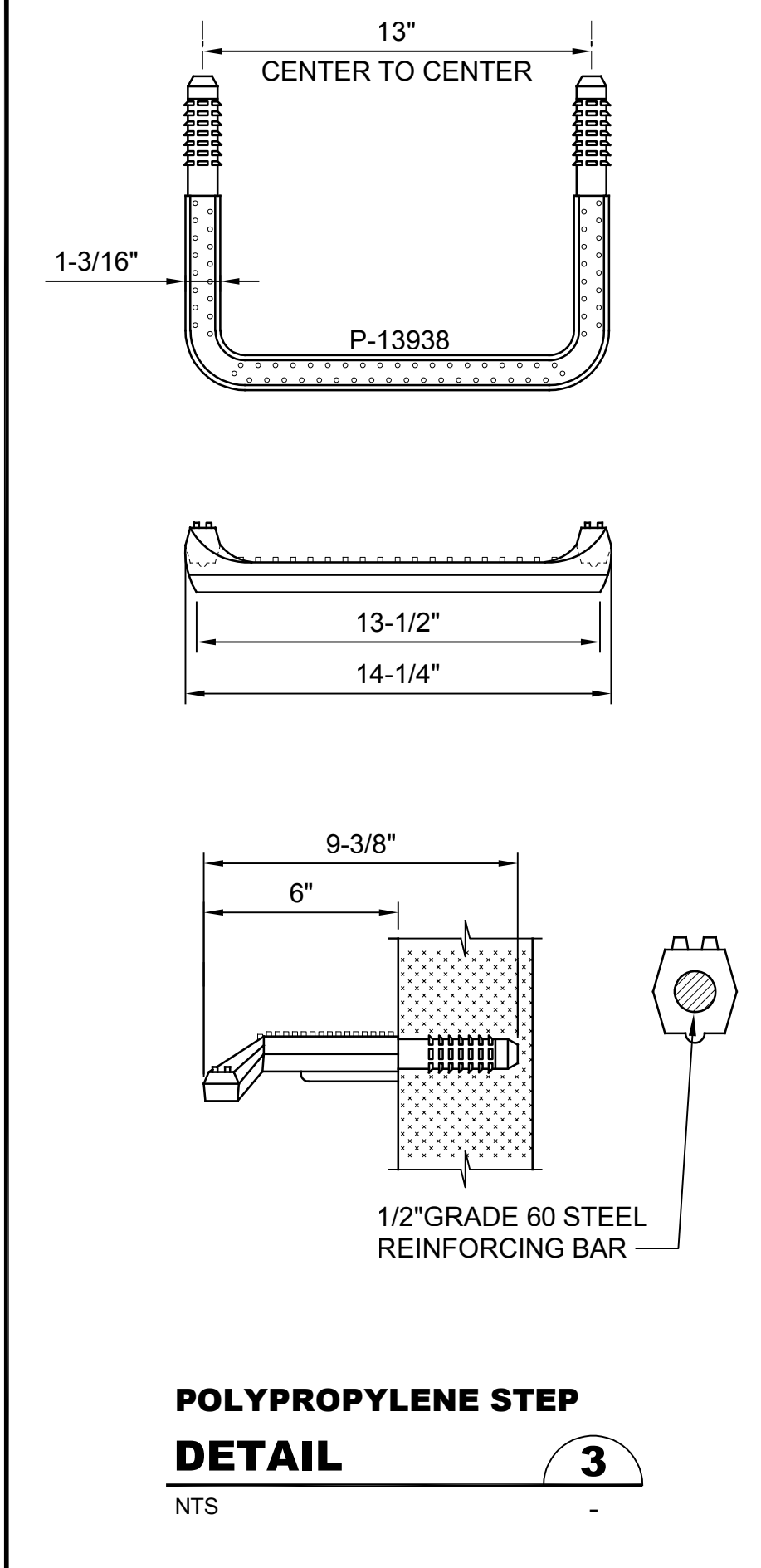

**POLYPROPYLENE STEP  
DETAIL**  
NTS

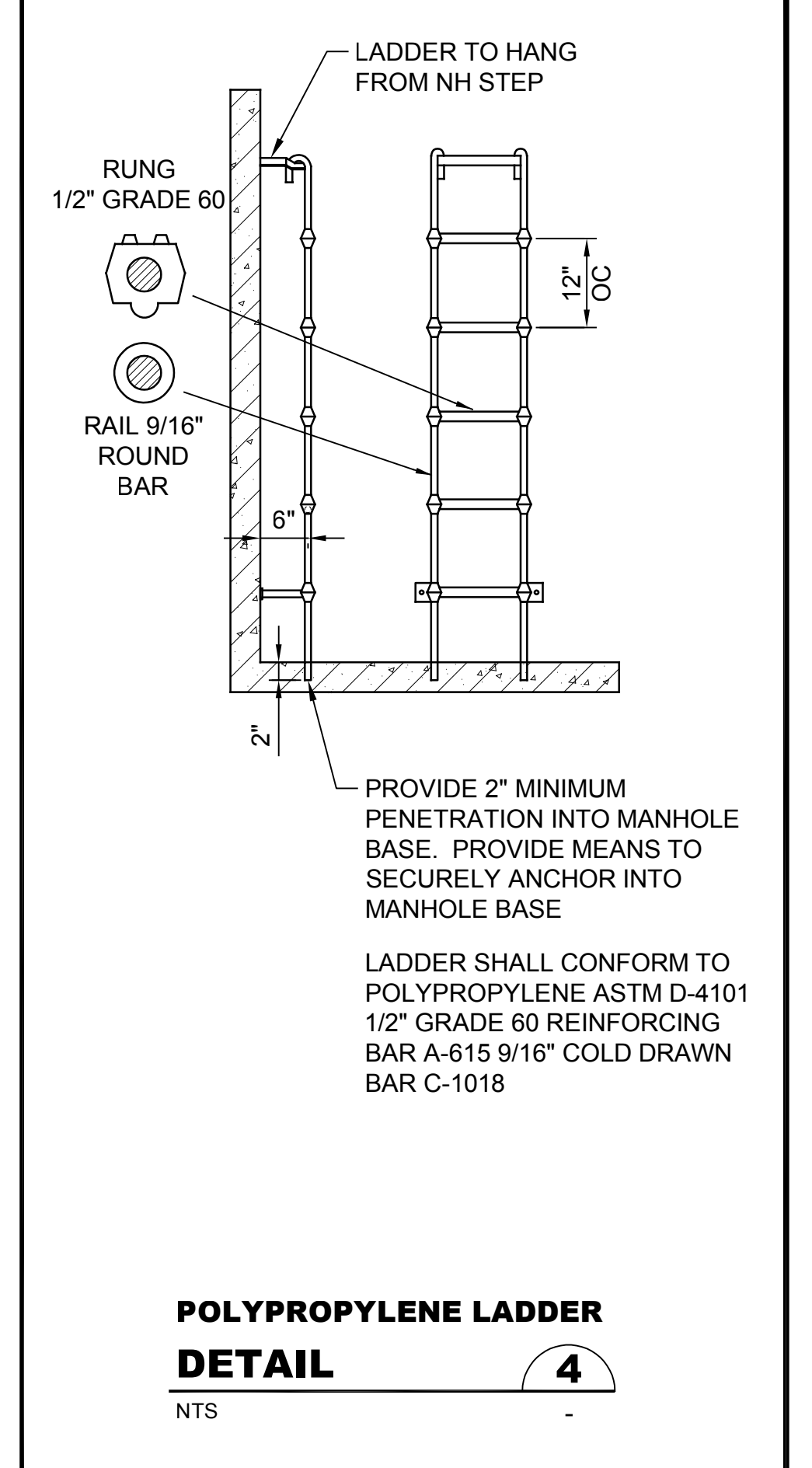

**POLYPROPYLENE LADDER  
DETAIL**  
NTS

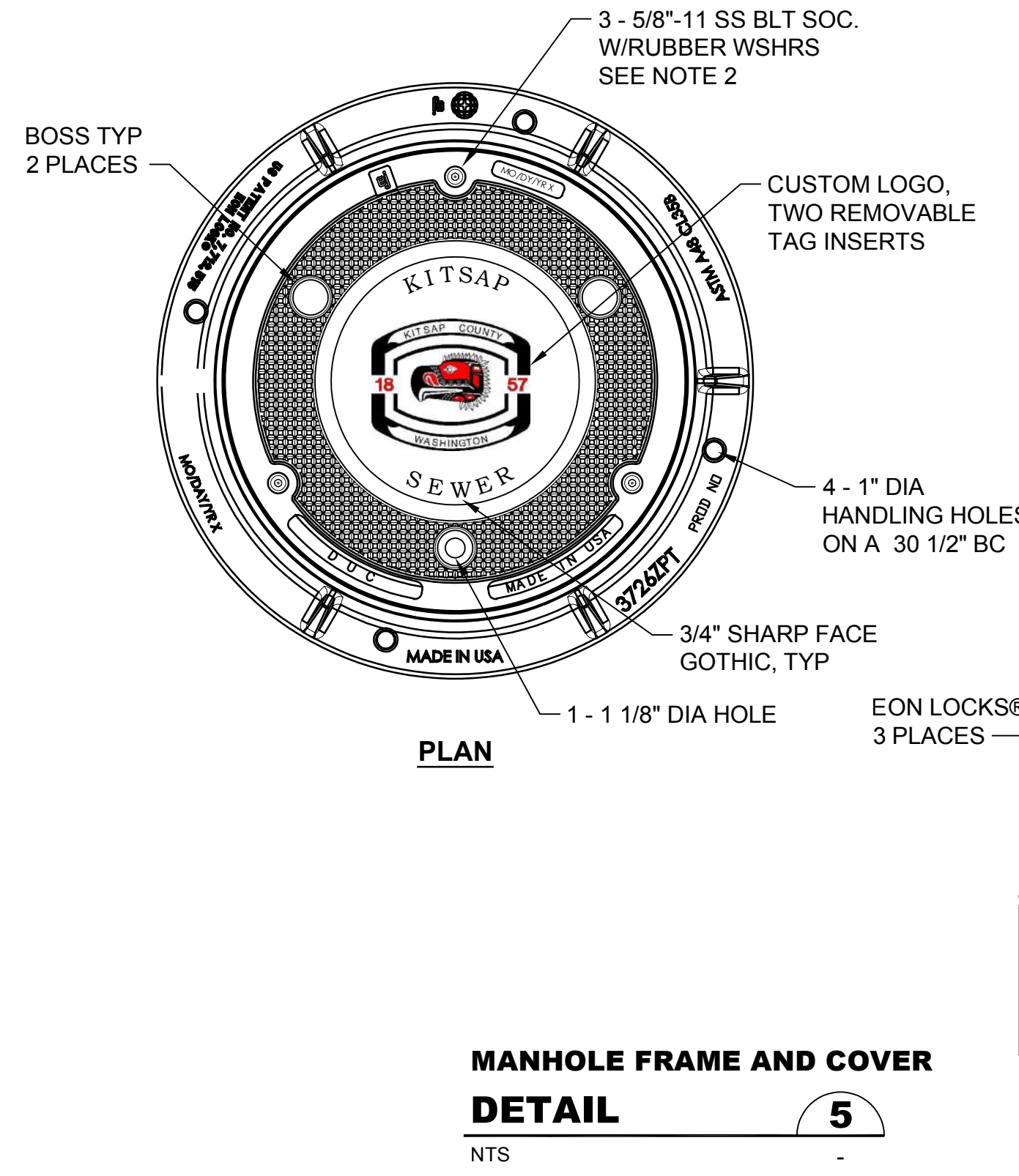

**MANHOLE FRAME AND COVER  
DETAIL**  
NTS

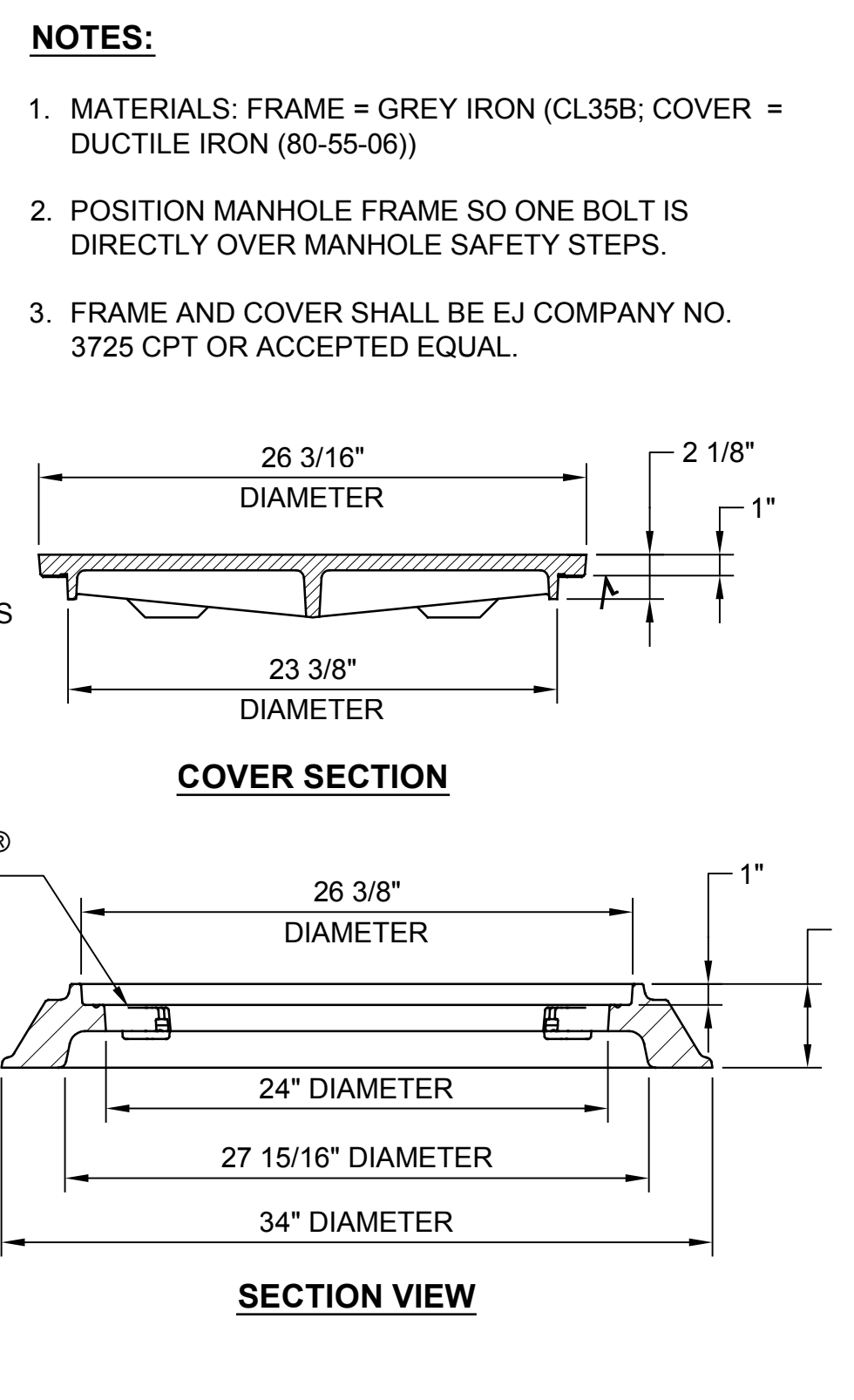

**COVER SECTION**  
**SECTION VIEW**

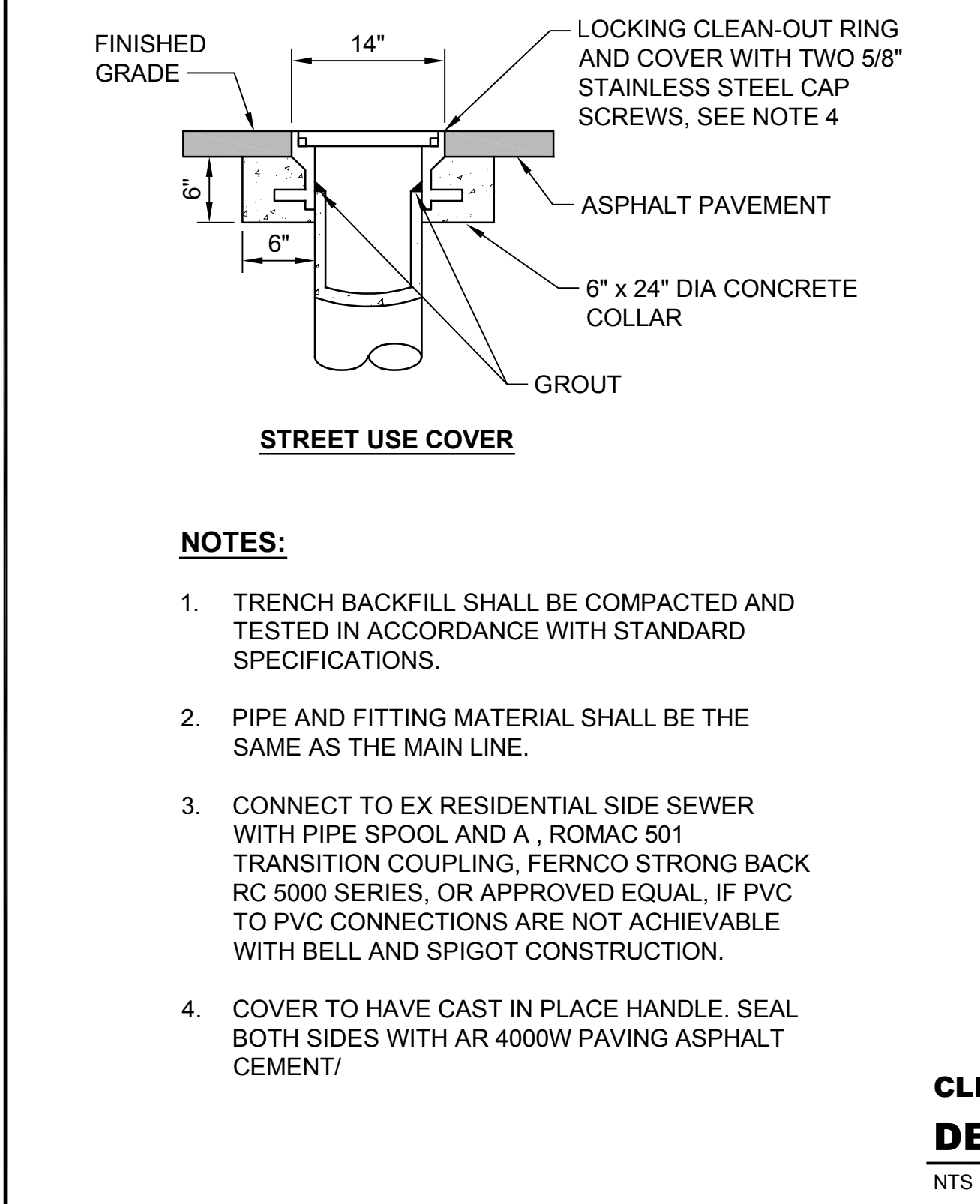

**STREET USE COVER**  
**NOTES:**  
1. TRENCH BACKFILL SHALL BE COMPACTED AND TESTED IN ACCORDANCE WITH STANDARD SPECIFICATIONS.  
2. PIPE AND FITTING MATERIAL SHALL BE THE SAME AS THE MAIN LINE.  
3. CONNECT TO EX RESIDENTIAL SIDE SEWER WITH PIPE SPOOL AND A ROMAC 501 TRANSITION COUPLING. FERNCO STRONG BACK RC 5000 SERIES, OR APPROVED EQUAL, IF PVC TO PVC CONNECTIONS ARE NOT ACHIEVABLE WITH BELL AND SPIGOT CONSTRUCTION.  
4. COVER TO HAVE CAST IN PLACE HANDLE. SEAL BOTH SIDES WITH AR 4000W PAVING ASPHALT CEMENT/

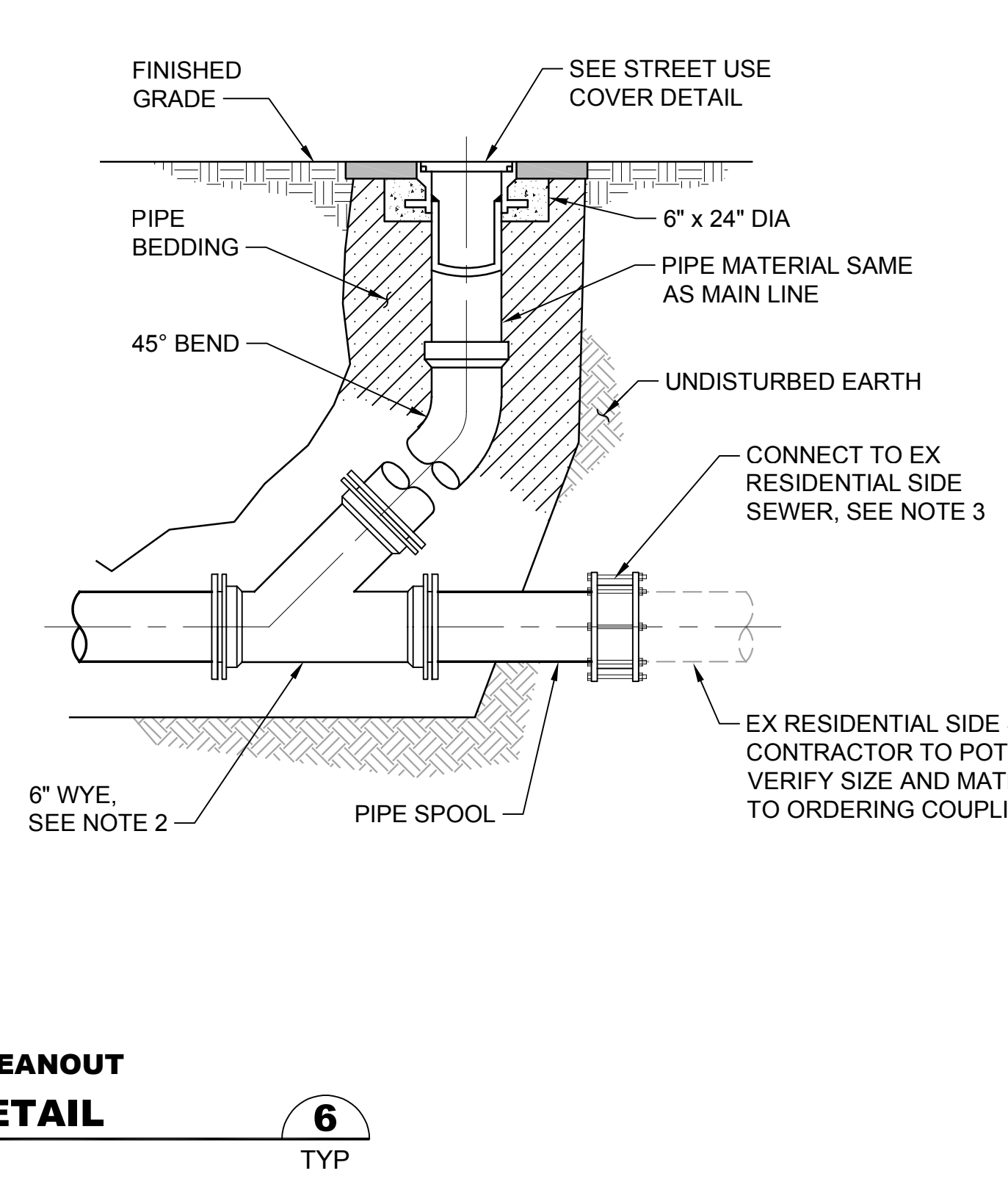

**CLEANOUT  
DETAIL**  
NTS TYP

**Call 48 Hours  
Before You Dig**  
1-800-424-5555  
UNDERGROUND SERVICE



Path: S:\Cadd\Kitsap County\21-10530 Silverdale Conveyance-PS 4 Uppgr\Design\Drawings\21-10530\_C-2\_Plot.dwg Plot date: Jan 06, 2023 02:17:09pm CAD User: solsoe  
Xref Filename: | Fisher | X21-10530\_TB | Dah | Palmtier |

No.	Revision	Date	By	App'd
	ISSUED FOR BID	01-2023	TF	RAD

**bhc**  
CONSULTANTS  
BHC Consultants, LLC  
1601 Fifth Avenue, Suite 500  
Seattle, Washington 98101  
206.505.3400  
206.505.3406 (fax)  
www.bhcconsultants.com

Designed: T. Fisher, P.E.  
Drawn: P. Simon  
Checked: R. Dorn, P.E.  
Scale: NTS  
One Inch at Full Scale  
If Not One Inch Scale Accordingly

**Kitsap County Public Works**  
614 Division Street, MS 26  
Port Orchard, WA 98366

**SILVERDALE CONVEYANCE SYSTEM AND PUMP STATION 4 UPGRADES**  
**MANHOLE, CATCH BASIN, AND CONNECTION DETAILS**

Drawing: **C-2**  
Sheet: **7** of **117**  
File: P21-10530\_C-2  
Date: January 2023

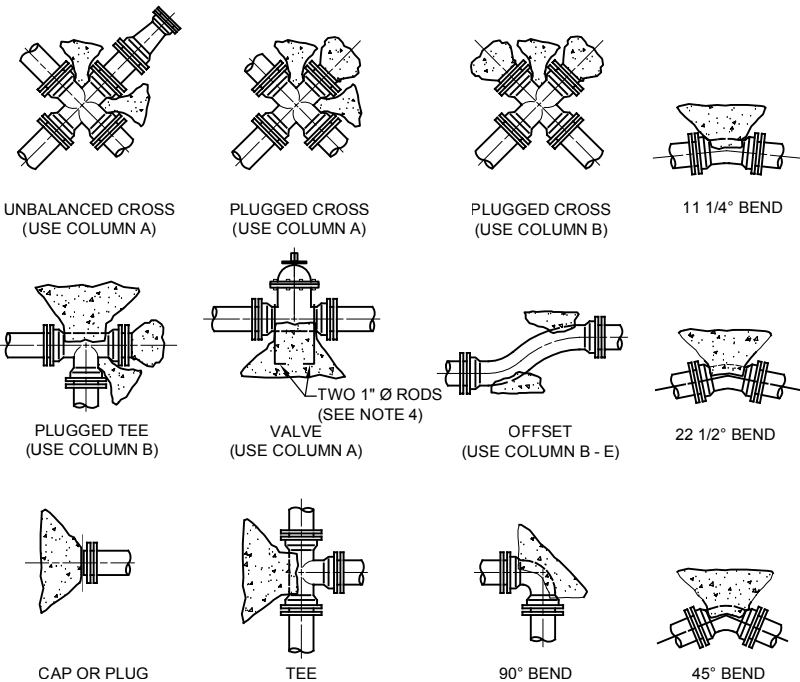

**THRUST BLOCKS  
DETAIL**

NTS 1 TYP

THRUST AT FITTINGS IN POUNDS													
SIZE (IN)	TEST PRESSURE (PSI)	A TEE AND DEAD ENDS		B 90° BEND		C 45° BEND		D 22.5° BEND		E 11.25° BEND		F DIAMETER RESTRAINT ROD	G ALLOWABLE THRUST PER RESTRAINT ROD (LBS)
		THRUST (PSI)	CONC VOL (CF)	THRUST (PSI)	CONC VOL (CF)	THRUST (PSI)	CONC VOL (CF)	THRUST (PSI)	CONC VOL (CF)	THRUST (PSI)	CONC VOL (CF)		
4	120	1,510	16	1,510	16	1,070	11	508	6	295	3	5/8"	3,450
6	120	3,395	34	3,395	34	2,405	25	1,300	13	665	7	3/4"	5,150
8	120	6,035	61	6,035	61	4,270	43	2,310	24	1,180	12	3/4"	5,150
10	120	9,425	95	9,425	95	6,665	67	3,610	37	1,840	19	7/8"	7,150
12	120	13,575	136	13,575	136	9,600	96	5,195	52	2,650	27	7/8"	7,150
14	120	18,475	185	18,475	185	13,065	131	7,075	71	3,605	37	1"	9,350
16	120	24,130	242	24,130	242	17,065	171	9,235	93	4,710	48	1"	9,350
18	120	30,540	306	30,540	306	21,600	216	11,690	117	5,960	60	1 1/8"	11,800
20	120	37,700	377	37,700	377	26,660	267	14,430	145	7,355	74	1 1/8"	11,800
24	120	54,290	543	54,290	543	38,390	384	20,780	208	10,595	106	1 1/4"	15,000
30	120	84,825	849	84,825	849	59,985	600	32,465	325	16,550	166	1 1/4"	15,000

SOIL TYPE	SAFE BEARING LOAD PSF
MUCK, PEAT, ETS.	0
SOFT CLAY	1,000
SAND	2,000
SAND AND GRAVEL	3,000
SAND AND GRAVEL CEMENTED WITH CLAY	4,000
HARD SHALE	10,000

**NOTES:**

- CONTRACTOR TO PROVIDE BLOCKING ADEQUATE TO WITHSTAND FULL TEST PRESSURE.
- DIVIDE THRUST BY SAFE BEARING LOAD TO DETERMINE REQUIRED AREA (IN SQUARE FEET) OF CONCRETE TO DISTRIBUTE LOAD.
- AREAS TO BE ADJUSTED FOR OTHER PRESSURE CONDITIONS.
- RESTRAINT RODS, NUTS, WASHERS AND APPURTENANCES SHALL BE CONSTRUCTED OF 304 SST. RODS SHALL BE ALL-THREAD DESIGN.
- JOINTS USING RODS FOR RESTRAINT SHALL NOT EXCEED ALLOWABLE THRUST PER RESTRAINT ROD AS SHOWN IN COLUMN G. IN NO CASE SHALL LESS THAN 2 RODS BE USED.

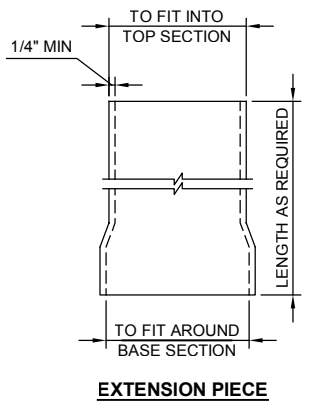
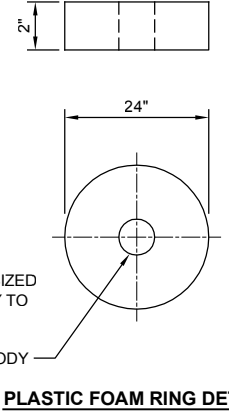
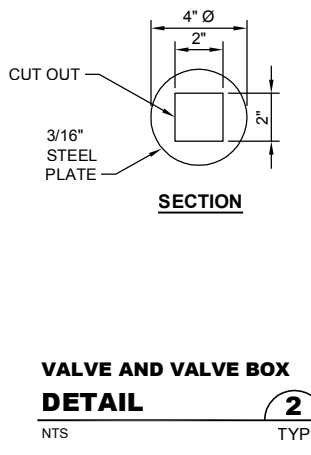
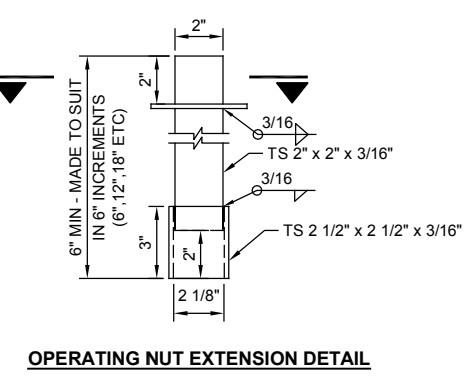
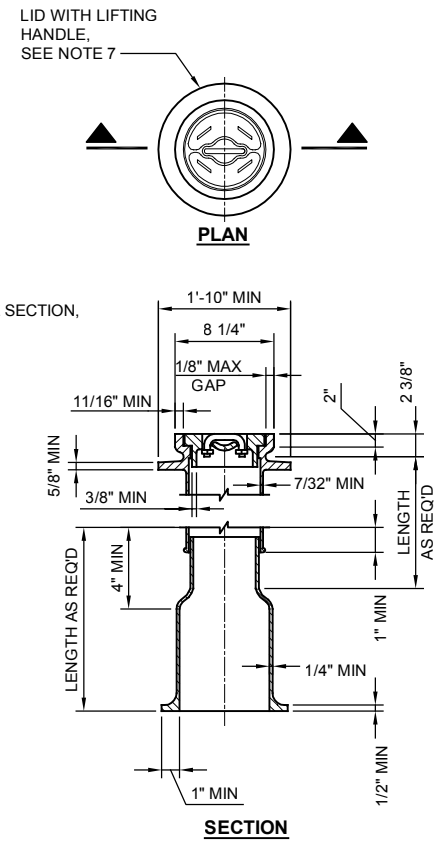
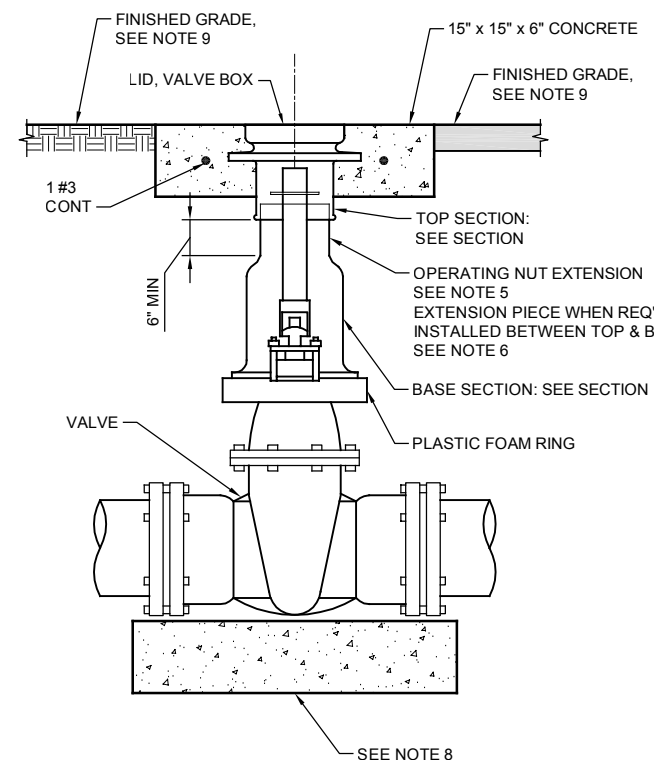

**NOTES:**

- FRAME AND COVER SHALL BE TESTED FOR ACCURACY OF FIT AND SHALL BE MARKED IN SETS FOR DELIVERY.
- CASTINGS AND EXTENSIONS SHALL BE HOT-DIPPED IN ASPHALTIC VARNISH ROYSTON ROSKOTE #612XM OR 2 COATS OF MASTIC ROYSTON INSIDE AND OUT.
- VALVE BOXES SHALL BE RICH #045: TOP SECTION, LID AND BASE; OR OLYMPIC FOUNDRY: LID #1908-33, TOP SECTION #1106-33, BASE SECTION #1301-33 OR APPROVED EQUAL.
- ALL CASTINGS SHALL BE DUCTILE OR GREY CAST IRON.
- AN OPERATING NUT EXTENSION SHALL BE INSTALLED WHEN THE GROUND SURFACE IS MORE THAN 2'-6" ABOVE THE VALVE OPERATING NUT. THE OPERATING NUT EXTENSION SHALL EXTEND INTO THE TOP SECTION OF THE STANDARD VALVE BOX AND SHALL CLEAR THE BOTTOM OF THE LID BY 6" MINIMUM.
- EXTENSION PIECES (WHEN USED) SHALL CONFORM TO MINIMUM THICKNESS REQUIREMENTS AND SHALL FIT INTO THE TOP SECTION AND OVER THE BOTTOM SECTION.
- LID SHALL BE STAMPED "SEWER".
- PLACE 16" - 24" GATE VALVES ON COMMERCIAL CLASS CONCRETE PAD. (12" D x 42" W x 30" L).
- SURFACE RESTORATION SHALL BE IN ACCORDANCE WITH LOCAL REGULATORY REQUIREMENTS AND AS SHOWN ON THE SITE RESTORATION DRAWINGS.

Path: S:\Cadd\Kitsap County\21-10530 Silverdale Conveyance PS 4 Upgh\Design\Drawings\PS 4 Upgh\Drawings\21-10530\_C-3\_Plot.dwg; Plot date: Mar 20, 2023 02:14:44pm; CAD User: solsoe; Xref Filename: | Fisher | X21-10530\_TB | Dahl | Palmalter |

No.	Revision	Date	By	App'd
	ISSUED FOR BID	01-2023	TF	RAD

**bhc**  
CONSULTANTS

**BHC Consultants, LLC**  
1601 Fifth Avenue, Suite 500  
Seattle, Washington 98101  
206.505.3400  
206.505.3406 (fax)  
www.bhcconsultants.com

Designed: T. Fisher, P.E.  
Drawn: P. Simon  
Checked: R. Dorn, P.E.

Scale:  
NTS  
One Inch at Full Scale  
If Not One Inch Scale Accordingly



**Kitsap County Public Works**  
614 Division Street, MS 26  
Port Orchard, WA 98366

**SILVERDALE CONVEYANCE SYSTEM AND PUMP STATION 4 UPGRADES**

**THRUST BLOCK AND VALVE BOX  
DETAILS**

**Call 48 Hours  
Before You Dig**  
1-800-424-5555  
UNDERGROUND SERVICE



Drawing: **C-3**  
Sheet: **8** of **117**  
File: P21-10530-PS4\_C-3  
Date: January 2023



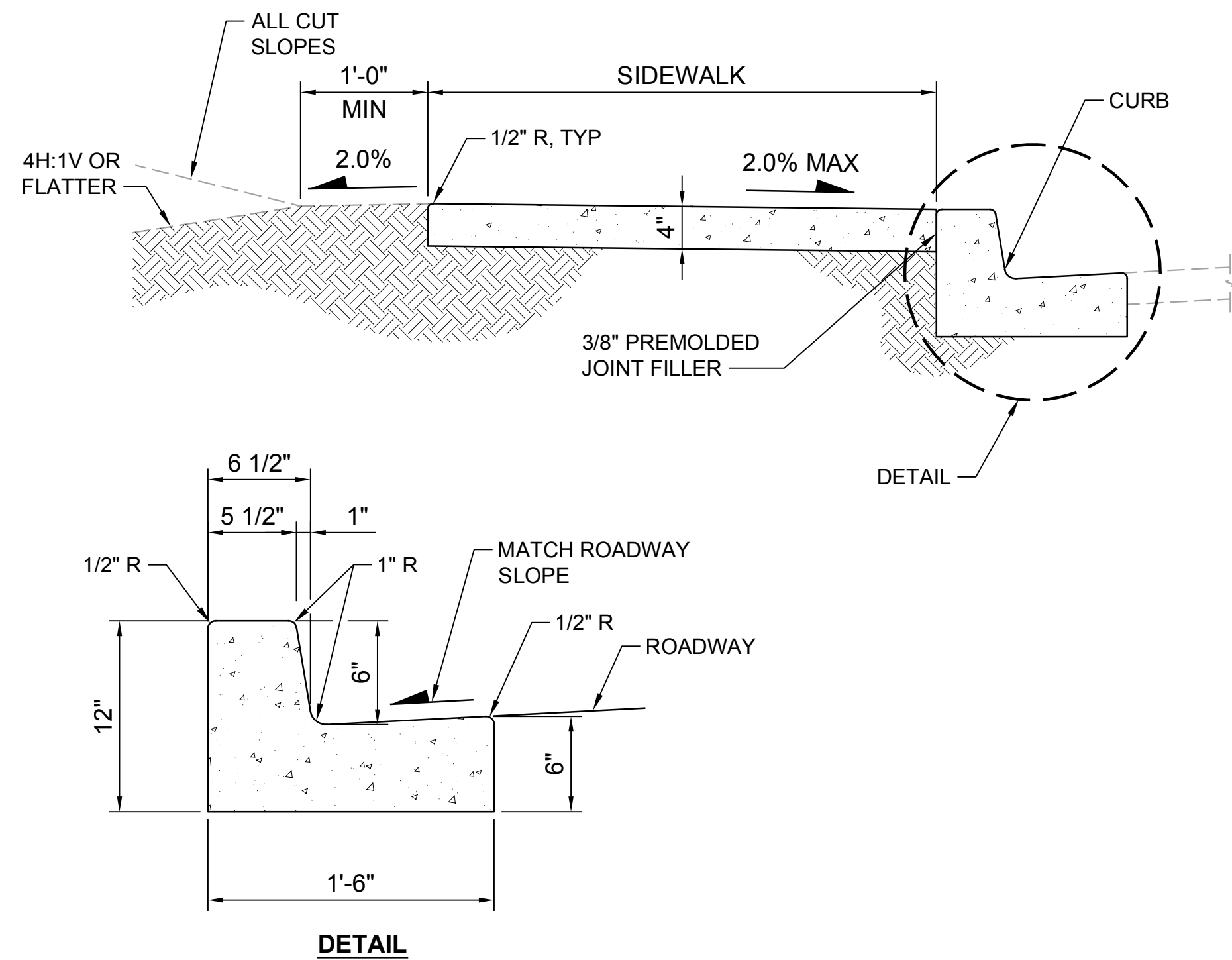

**SURFACE RESTORATION TYPE 1  
DETAIL**  
NTS 1 TYP

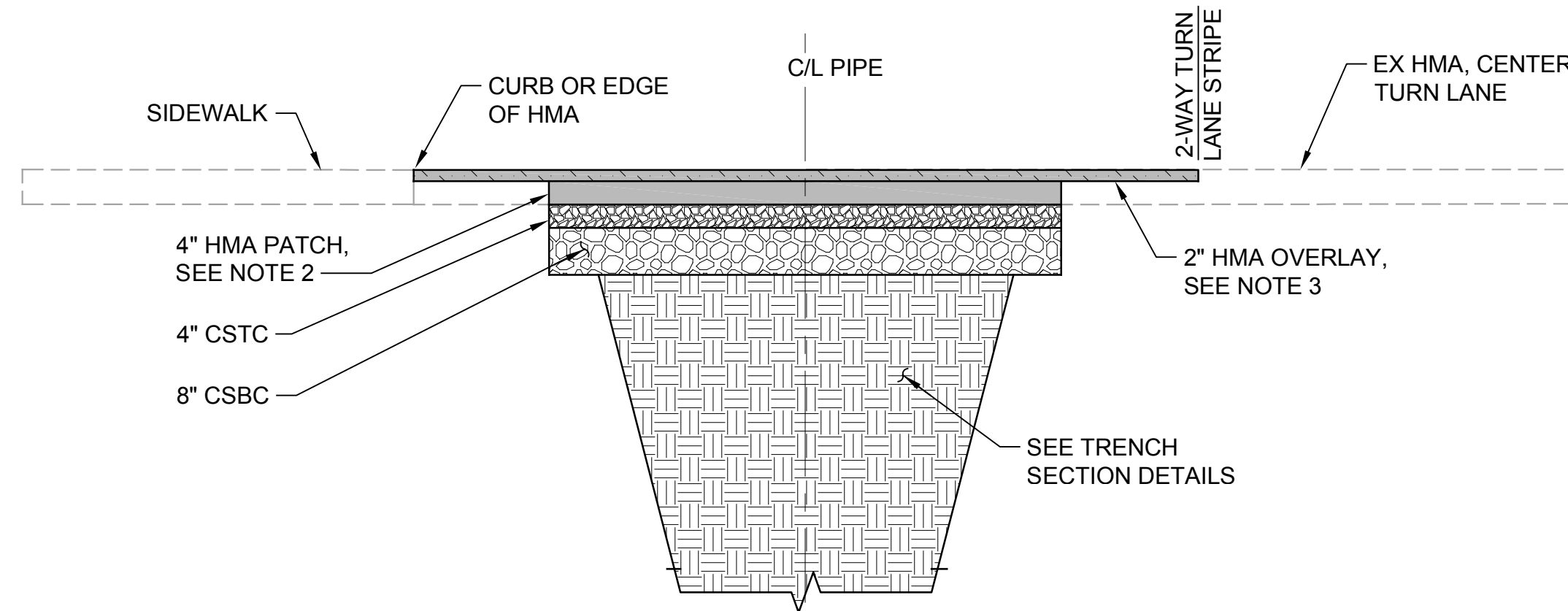

**NOTES:**

1. SAW CUT EXISTING AC PAVEMENT 12" WIDER THAN TOP OF TRENCH. CUT SHALL BE STRAIGHT AND FULL DEPTH. REMOVE AND DISPOSE OF EXISTING AC OVER TRENCH. CLEAN, HEAT, AND TACK EDGES OF EXISTING AC WITH SEALER PRIOR TO INSTALLING NEW HMA PATCH.
2. SAW CUT EXISTING AC PAVEMENT AT EDGE OF 2-WAY TURN LANE. GRIND AND REMOVE EXISTING AC TO FACILITATE HMA OVERLAY. CUTS SHALL BE STRAIGHT AND VERTICAL. CLEAN, HEAT, AND TACK EDGES WITH SEALER. PROVIDE SMOOTH TRANSITION BETWEEN EXISTING ROADWAY AND NEW HMA OVERLAY.
3. EXISTING AC MAY BE GROUND AND REUSED IN LIEU OF CSBC.
4. GRIND TRANSITION ZONES AT LIMITS OF PAVING PERPENDICULAR TO THE CENTERLINE.
5. ALL JOINTS SHALL BE SEALED WITH A 12" WIDE STRIP OF AR2000 ASPHALT SEALER CENTERED ON JOINT.
6. MATCH ELEVATIONS OF EXISTING PAVEMENT, DRIVEWAYS, SHOULDERS, AND OTHER SURFACE FEATURES.
7. RESTORE ALL DISTURBED PAVEMENT MARKINGS.

**SURFACE RESTORATION TYPE 2  
DETAIL**  
NTS 2 TYP

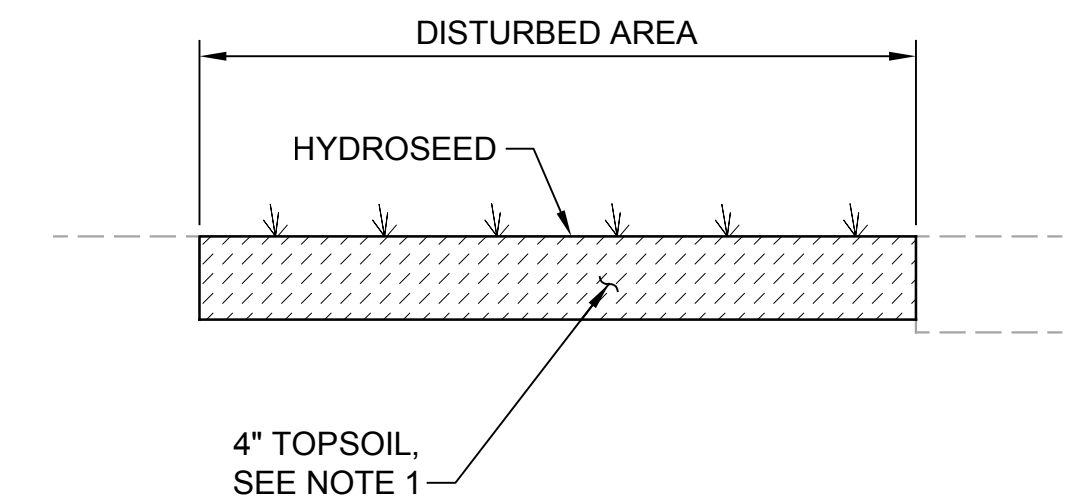

**NOTES:**

1. REGRADE DISTURBED AREAS TO ORIGINAL CONTOURS LESS DEPTH OF NEW TOPSOIL PRIOR TO INSTALLING NEW TOPSOIL. RESTORE ORIGINAL GRADE AND ELEVATIONS AFTER INSTALLATION OF TOPSOIL.

**SURFACE RESTORATION TYPE 3  
DETAIL**  
NTS 3 TYP

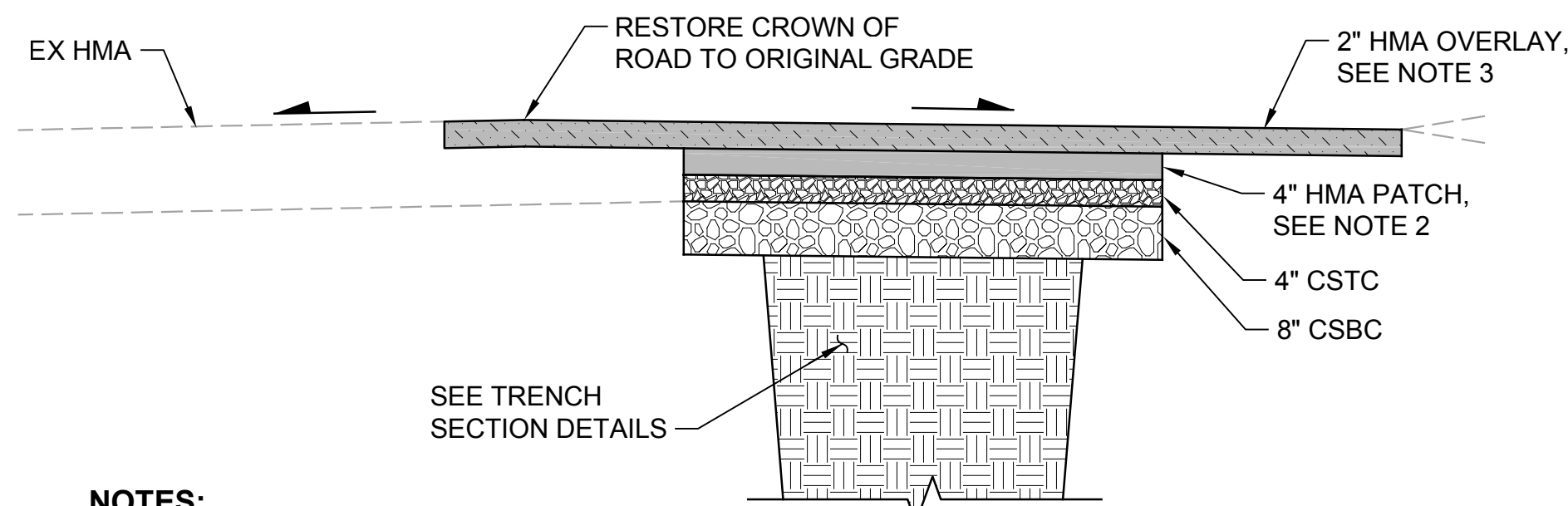

**NOTES:**

1. REFERENCE CROWN OF STREET PRIOR TO CUTTING EXISTING AC PAVEMENT.
2. SAW CUT EXISTING AC PAVEMENT 12" WIDER THAN TOP OF TRENCH. CUT SHALL BE STRAIGHT AND FULL DEPTH. REMOVE AND DISPOSE OF EXISTING AC OVER TRENCH. CLEAN, HEAT, AND TACK EDGES OF EXISTING AC WITH SEALER PRIOR TO INSTALLING NEW HMA PATCH.
3. SAWCUT EXISTING AC PAVEMENT AT EDGE OF OVERLAY AS SHOWN ON PLAN VIEW. GRIND AND REMOVE EXISTING AC TO FACILITATE NEW HMA OVERLAY. HMA OVERLAY TO MATCH EXISTING CROWN OF ROAD, CURB LINES, AND DRIVEWAY ELEVATIONS. CLEAN, HEAT, AND TACK EDGES OF EXISTING AC WITH SEALER PRIOR TO INSTALLING NEW HMA OVERLAY. PROVIDE SMOOTH TRANSITION BETWEEN EXISTING ROADWAYS/ DRIVEWAYS AND NEW HMA OVERLAY.
4. EXISTING AC MAY BE GROUND AND REUSED IN LIEU OF CSBC.
5. ALL JOINTS SHALL SEALED WITH A 12" WIDE STRIP OF AR2000 ASPHALT SEALER CENTERED ON JOINT.
6. RESTORE CENTERLINE STRIPE, FOG LINE AND ALL OTHER PAVEMENT MARKINGS THAT EXISTED PRIOR TO CONSTRUCTION.

**SURFACE RESTORATION TYPE 4  
DETAIL**  
NTS 4 TYP

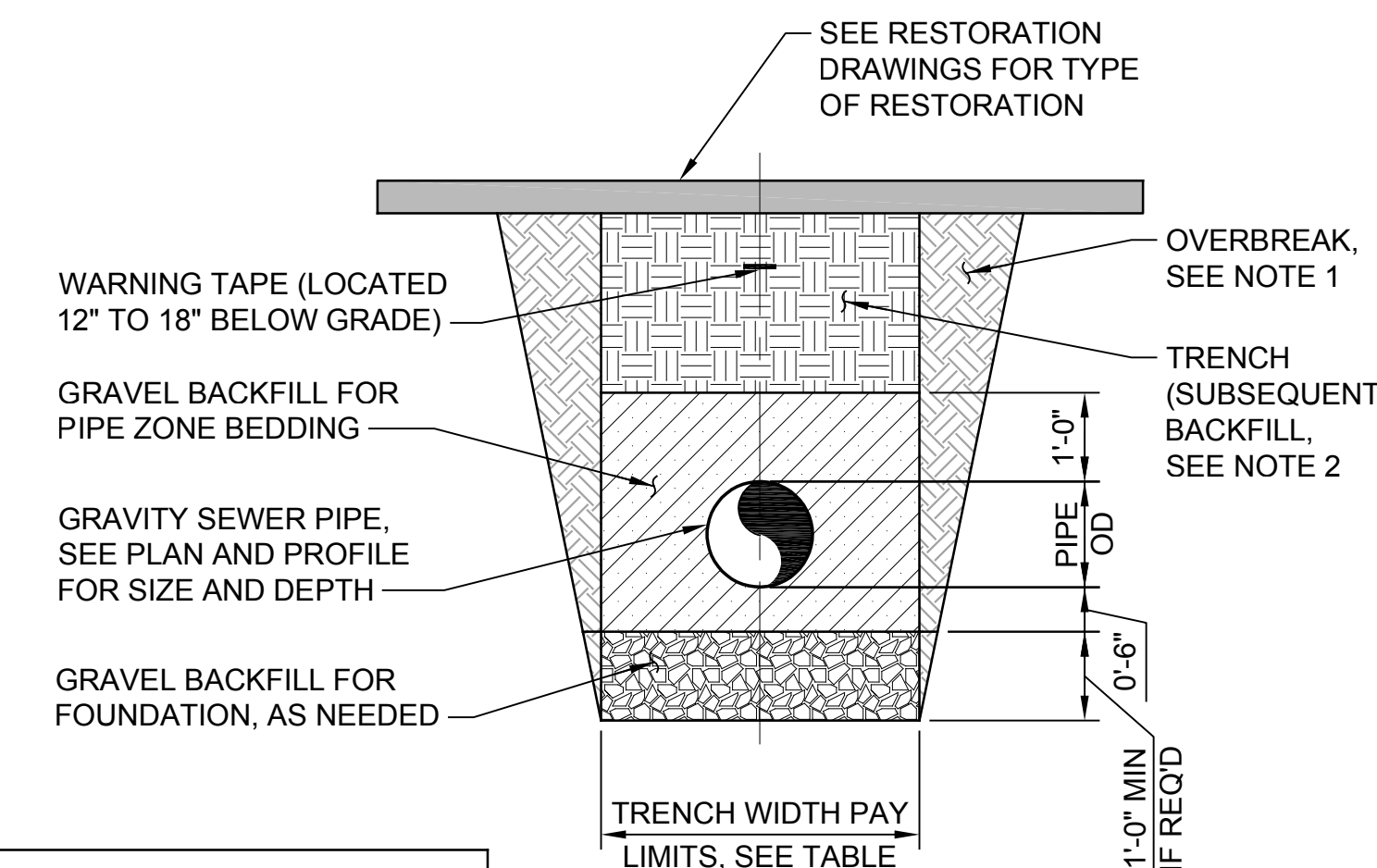

**TRENCH WIDTH PAY LIMITS**

PIPE	MAX TRENCH WIDTH PAY LIMIT
8" SS	3'-0"
15" SS	3'-6"
18" SS	4'-0"
20" SS	4'-0"

**NOTES:**

1. EXCAVATION AND BACKFILL BEYOND THE TRENCH WIDTH PAY LIMITS SHALL BE TREATED ON OVER BREAK AND SHALL BE THE CONTRACTOR'S RESPONSIBILITIES.
2. ALL EXCAVATION OVER 4' IN DEPTH SHALL HAVE A TRENCH SUPPORT SYSTEM AS REQUIRED BY STATE AND FEDERAL LAW.

**TRENCH TYPE 1 GRAVITY SEWER MAIN  
DETAIL**  
NTS 5 TYP

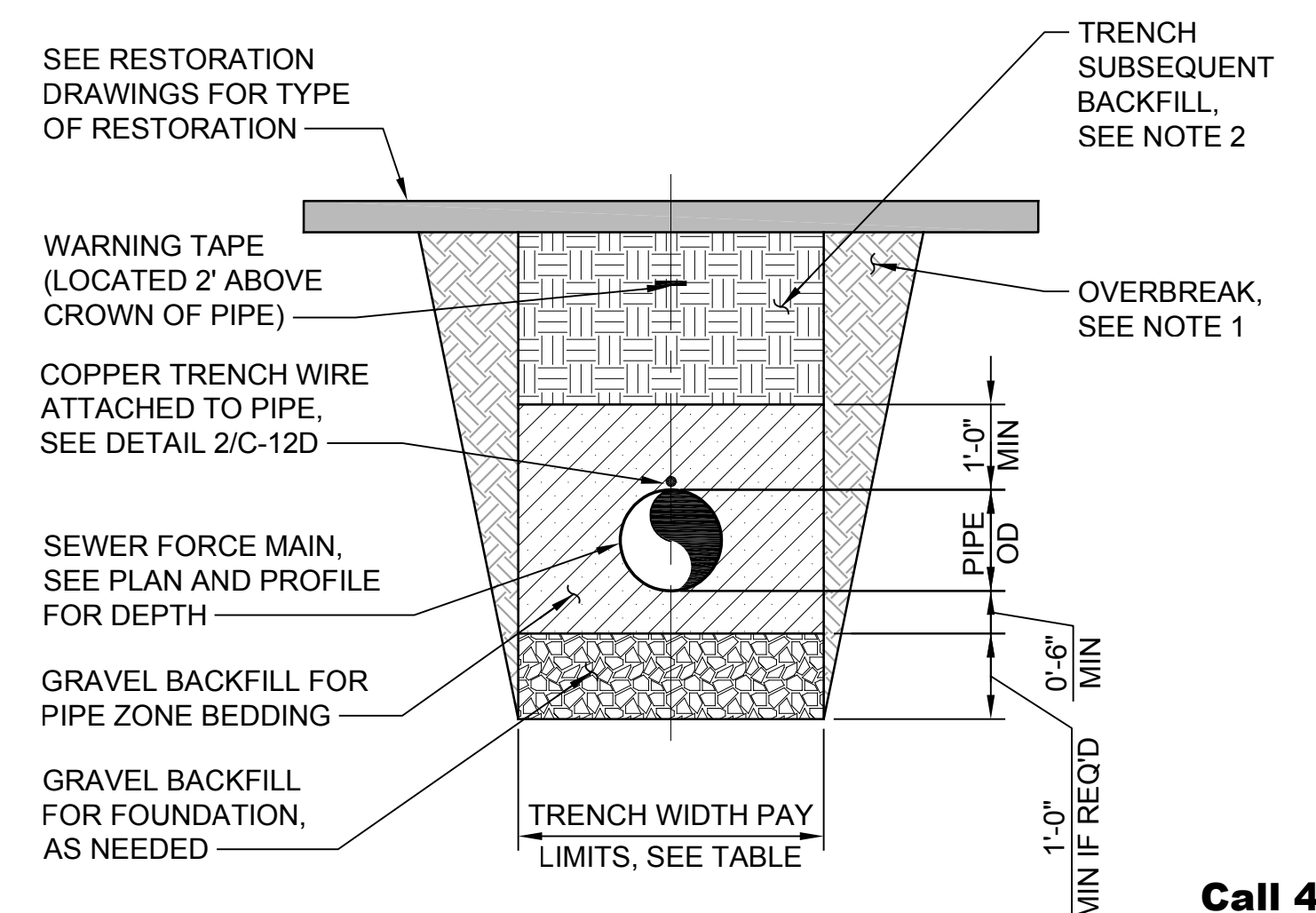

**TRENCH WIDTH PAY LIMITS**

PIPE	MAX TRENCH WIDTH PAY LIMIT
12" FM	3'-0"
14" FM	3'-6"
20" FM	4'-0"

**TRENCH TYPE 2 SEWER FORCE MAIN  
DETAIL**  
NTS 6 TYP

**Call 48 Hours Before You Dig**  
1-800-424-5555  
UNDERGROUND SERVICE

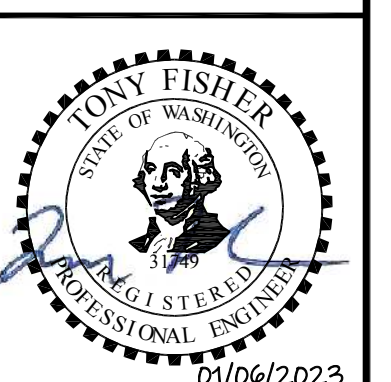

Path: S:\Cadd\Kitsap County\21-10530 Silverdale Conveyance-PS 4 Uprg\Design\Drawings\21-10530\_C-4 Plot date: Jan 06, 2023 02:26:39pm CAD User: soisee  
Xref Filename: I\Fisher\1\21-10530\_1B\1\Detail1.rvt

No.	Revision	Date	By	App'd
	ISSUED FOR BID	01-2023	TF	RAD

**bhc** CONSULTANTS  
BHC Consultants, LLC  
1601 Fifth Avenue, Suite 500  
Seattle, Washington 98101  
206.505.3400  
206.505.3406 (fax)  
www.bhcconsultants.com

Designed: T. Fisher, P.E.  
Drawn: P. Simon  
Checked: R. Dorn, P.E.

Scale: N/A  
One Inch at Full Scale  
If Not One Inch Scale Accordingly

**Kitsap County Public Works**  
614 Division Street, MS 26  
Port Orchard, WA 98366

**SILVERDALE CONVEYANCE SYSTEM AND PUMP STATION 4 UPGRADES**  
**TRENCH AND SURFACE RESTORATION DETAILS**

Drawing: **C-4**  
Sheet: **9** of **117**  
File: P21-10530\_C-4  
Date: January 2023

Path: S:\Cadd\Kitsap County\21-10530 Silverdale Conveyance\PS 4 Uprgh\Design\Drawings\21-10530\_C-5\_Plot.dwg; File: 21-10530\_C-5\_Plot.dwg; Date: Mar 20, 2023 02:18:20pm; CAD User: solsoe; Xref File: 21-10530\_TB | Dahj | Palmtail |

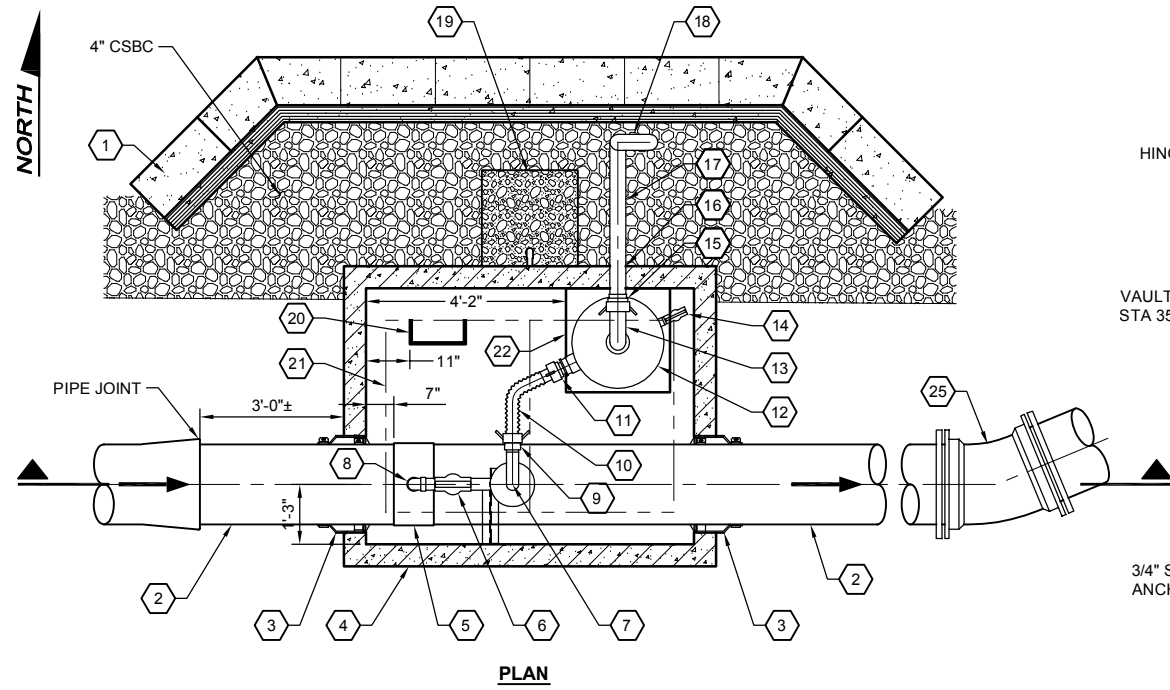

**PLAN**

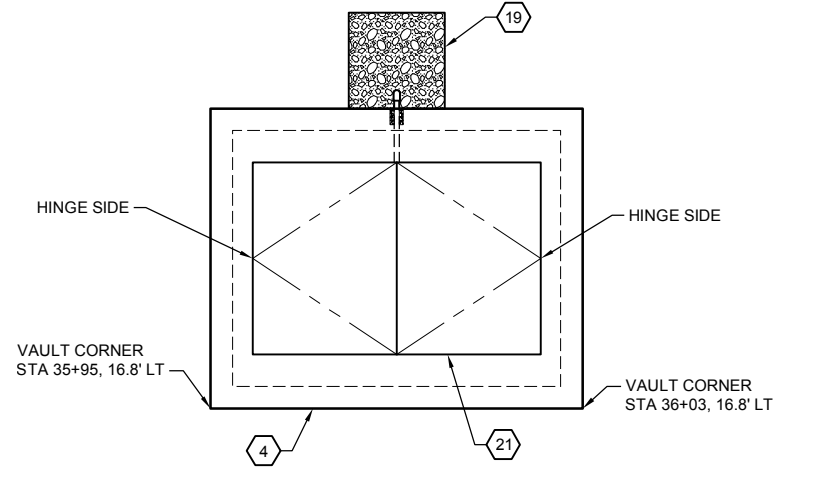

**ACCESS HATCH PLAN**

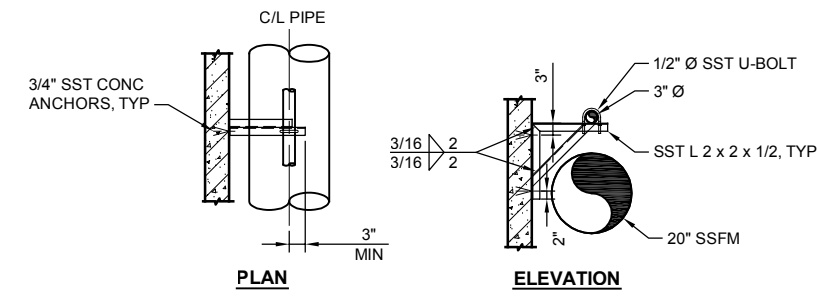

**AIR VAC PIPE SUPPORT**

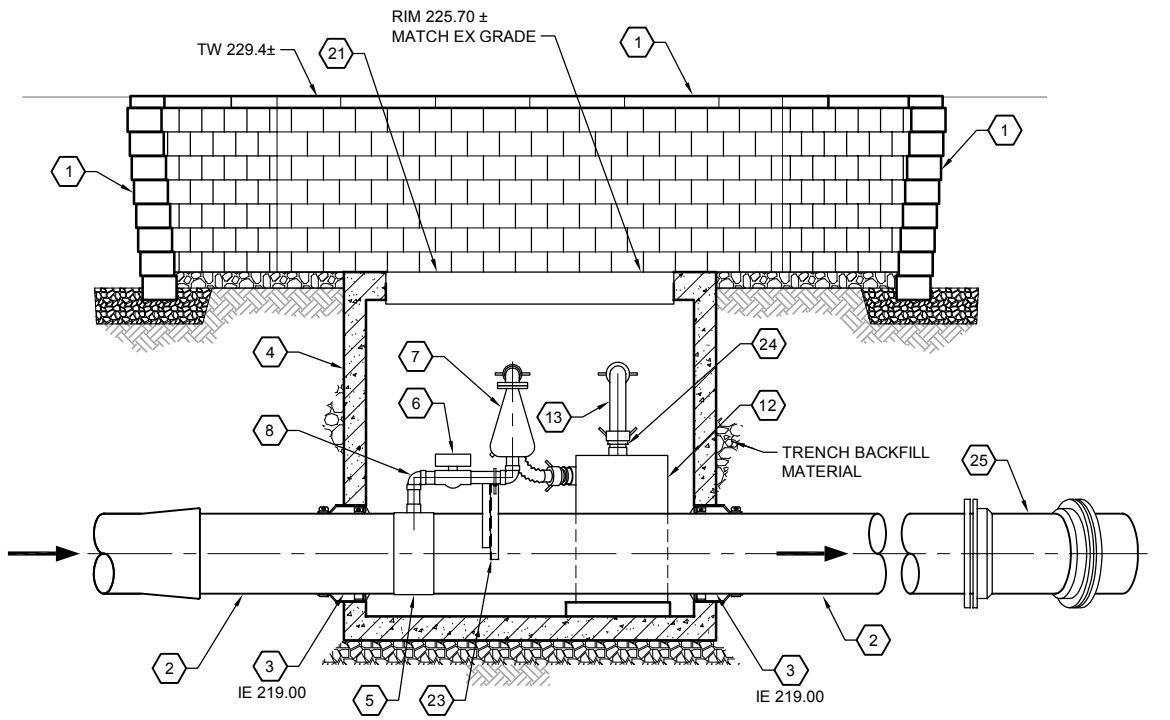

**SECTION A-A**

**AIR/VACUUM VAULT ASSEMBLY DETAIL**

NTS **1** C-1A

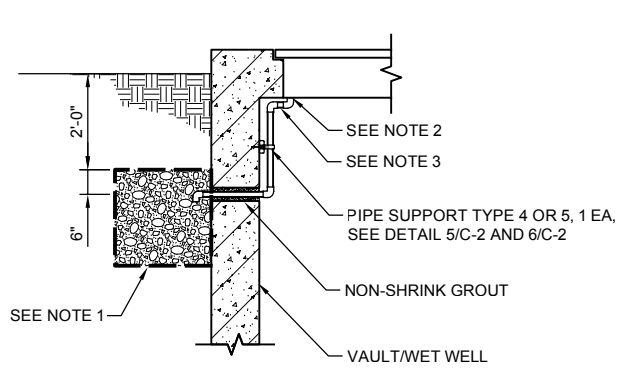

**NOTES:**

- 2' x 2' x 2' SUMP FILLED WITH GEOTEXTILE WRAPPED DRAIN ROCK.
- CONNECT TO HATCH DRAIN PER MANUFACTURER'S RECOMMENDATIONS.
- SCH 80 PVC PIPE SIZED PER HATCH MANUFACTURERS RECOMMENDATIONS, MAINTAIN 2% MINIMUM SLOPE.

**HATCH DRAIN DETAIL**

NTS **2** TYP

**NOTES:**

- ROUTE FLEX HOSE FROM AIR/VACUUM VALVE DISCHARGE TO CARBON CANISTER INTAKE, DEFLECTING VERTICALLY AND HORIZONTALLY AS NECESSARY.
- VAULT WALLS SHALL BE FULL WIDTH THICKNESS AT ALL PIPE PENETRATIONS.

**AIR/VACUUM VAULT ASSEMBLY COMPONENTS:**

- |  |  |
|--|--|
| 1 RETAINING WALL, PER DETAIL 3/-   | 13 4" FLEXIBLE URETHANE HOSE WITH TYPE C CAMLOCK ADAPTORS ON BOTH ENDS   |
| 2 20" C905 PVC PIPE  | 14 2" DRAIN WITH PVC BALL VALVE  |
| 3 WALL PENETRATION TYPE 1 PER DETAIL 7/C-9D  | 15 4" TYPE A ADAPTOR (ALUM CAM/GROOVE x FIPT)  |
| 4 PRECAST CONCRETE VAULT (7'-0" L x 5'-6" W x 6'-0" H, INSIDE DIM), SEE NOTE 2   | 16 CORE HOLE FOR PIPE, FILL ANNULAR SPACE WITH NON-SHRINK GROUT  |
| 5 20" x 3" SST SERVICE SADDLE  | 17 4" SCH 80 PVC PIPE (THREADED x PE), 4" SCH 80 PVC 90° ELBOW (SOCKET x SOCKET), 4" SCH 80 PVC PIPE (PE x PE) |
| 6 3" PVC BALL VALVE W/ 3" SCH 80 NIPPLE (PE x PE, LENGTH AS REQ'D)   | 18 4" PVC GOOSE NECK WITH BUG SCREEN   |
| 7 3" ARI D-020 OR D-025 COMBINATION AIR/VACUUM VALVE, THREADED   | 19 HATCH DRAIN, PER DETAIL 2/-   |
| 8 3" SCH 80 PVC 90° ELBOW (FIPT x FIPT) W/ ONE 3" SCH 80 PVC NIPPLE (THREADED x PE, LENGTH AS REQ'D) & ONE 3" SCH 80 PVC NIPPLE (PE x PE, LENGTH AS REQ'D) | 20 ALUMINUM LADDER ATTACHED TO SIDE FRAME OF HATCH   |
| 9 3" TYPE F ADAPTOR (ALUM CAM/GROOVE x MALE NPT)   | 21 72" x 48" DOUBLE LEAF ALUM ACCESS HATCH, H-30 RATED   |
| 10 3" FLEXIBLE URETHANE HOSE WITH TYPE C CAMLOCK ADAPTORS ON BOTH ENDS, SEE NOTE 2   | 22 26" x 26" x 3.5" CONCRETE PAD   |
| 11 4" x 3" SST NIPPLE (MIPT x MIPT), 3" TYPE A ADAPTOR (ALUM CAM/GROOVE x FIPT)  | 23 AIR VAC PIPE SUPPORT. SEE DETAIL  |
| 12 ECS VENTADSORB PE STAND ALONE CANISTER OR ACCEPTED EQUAL  | 24 4" TYPE F ADAPTOR (ALUM CAM/GROOVE x MALE NPT)  |
|  | 25 20" DI 22.5° BEND, MJ x MJ  |

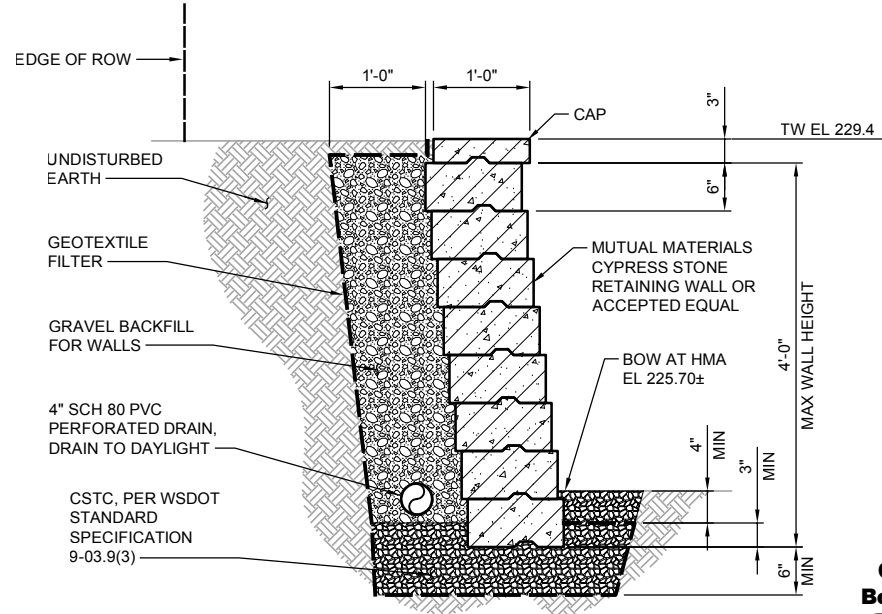

**RETAINING WALL DETAIL**

NTS **3** TYP

**Call 48 Hours Before You Dig**  
1-800-424-5555  
UNDERGROUND SERVICE



No.	Revision	Date	By	App'd
	ISSUED FOR BID	01-2023	TF	RAD

**bhc** CONSULTANTS  
BHC Consultants, LLC  
1601 Fifth Avenue, Suite 500  
Seattle, Washington 98101  
206.505.3400  
206.505.3406 (fax)  
www.bhcconsultants.com

Designed: T. Fisher, P.E.  
Drawn: P. Simon  
Checked: R. Dorn, P.E.

Scale:  
As Shown  
One Inch at Full Scale  
If Not One Inch Scale Accordingly



**Kitsap County Public Works**  
614 Division Street, MS 26  
Port Orchard, WA 98366

**SILVERDALE CONVEYANCE SYSTEM AND PUMP STATION 4 UPGRADES**  
**AIR/VACUUM VALVE VAULT DETAILS**

Drawing: **C-5**  
Sheet: **10** of **117**  
File: P21-10530\_C-5  
Date: January 2023

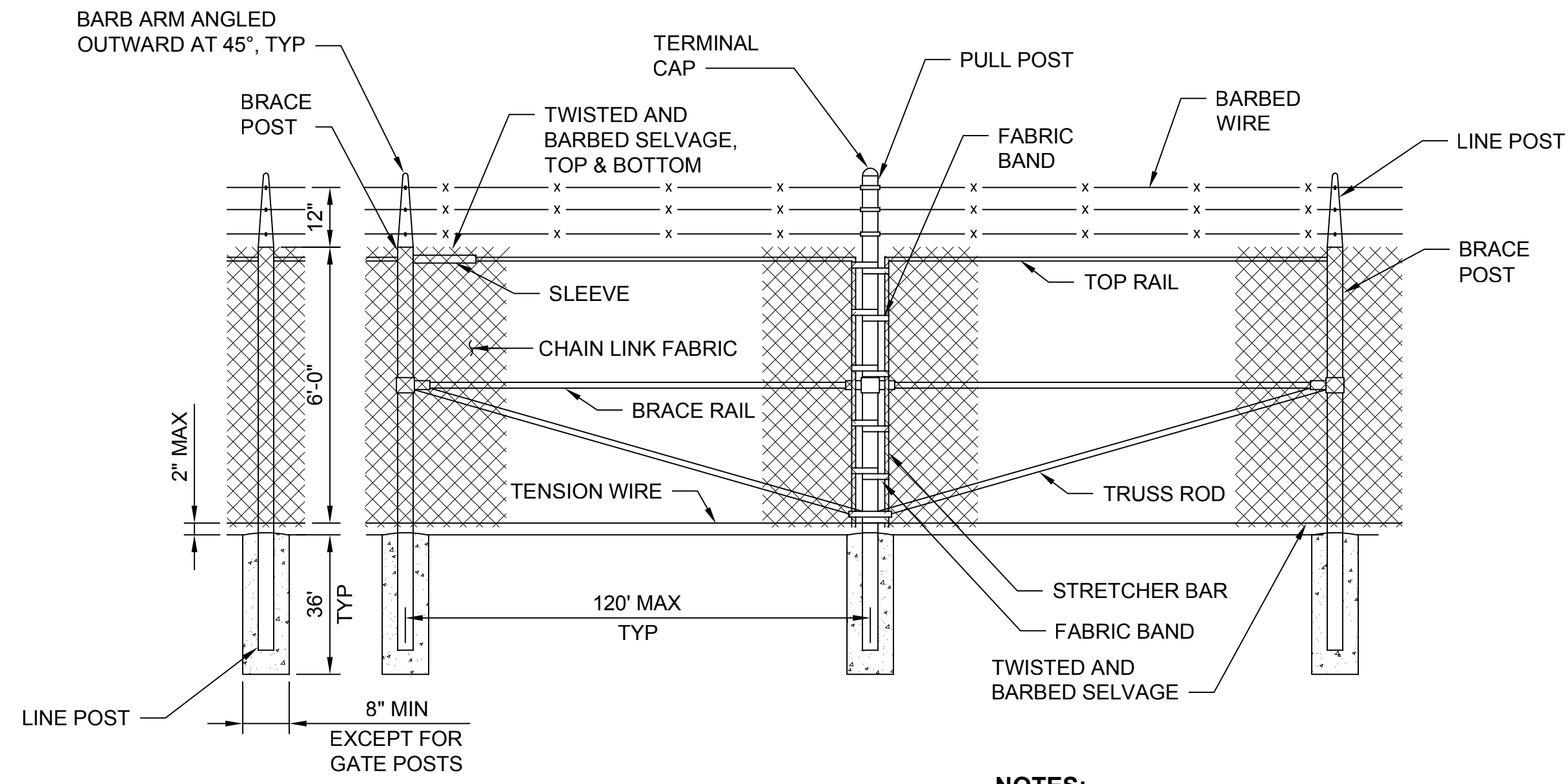

- NOTES:**
- CHAIN LINK FENCE MATERIALS SHALL COMPLY WITH SECTION 32 31 13 OF THE SPECIAL PROVISIONS.
  - TOP OF BOTTOM TENSION WIRES SHALL BE PLACED WITHIN THE LIMITS OF THE FIRST FULL FABRIC WEAVE.
  - PROVIDE BLACK PDS® BOTTOM LOCK FENCE SLATS BY PEXCO OR EQUAL, ALL LOCATIONS.

**CHAIN LINK FENCE  
DETAIL 1**  
NTS TYP

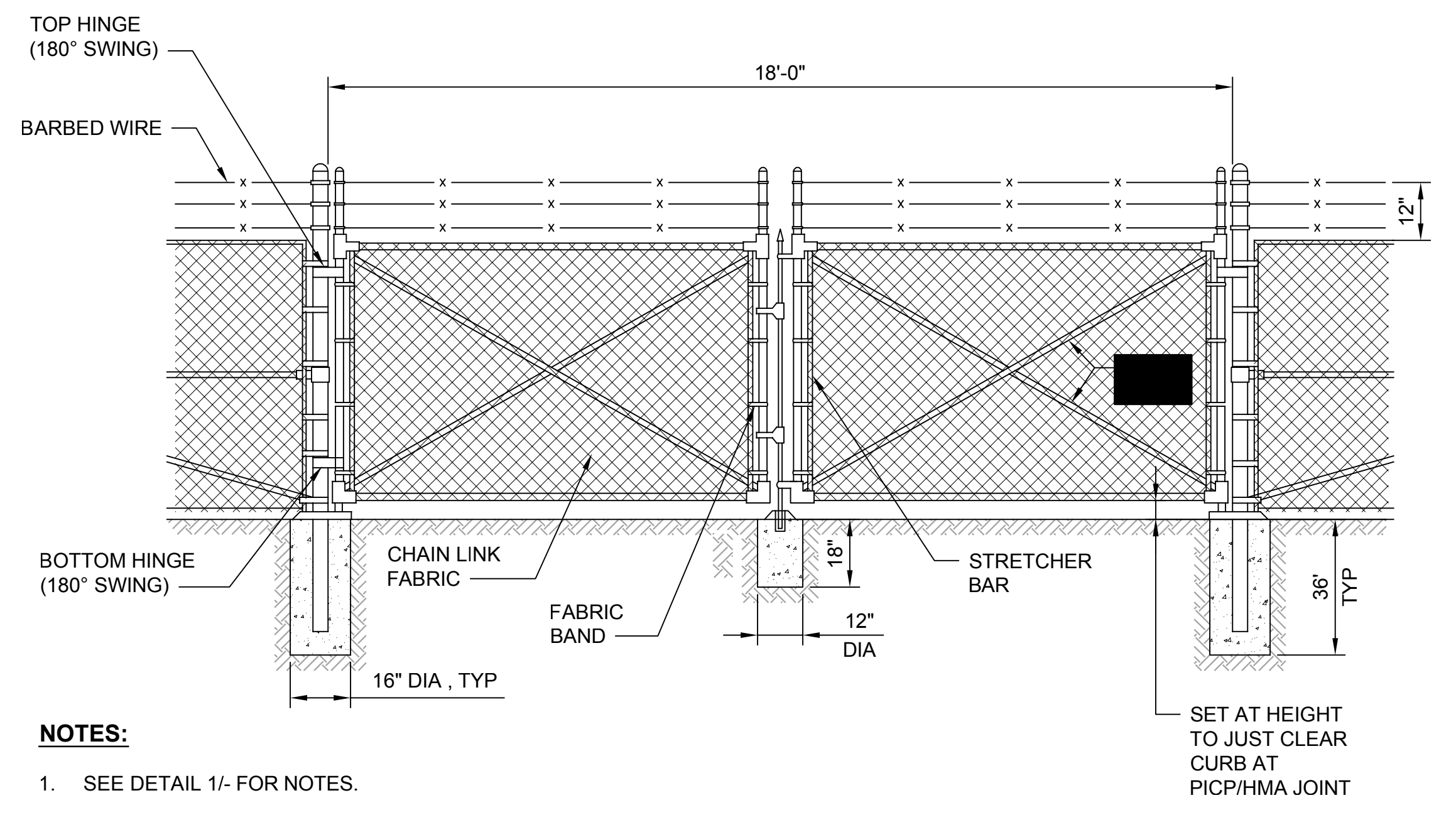

- NOTES:**
- SEE DETAIL 1/- FOR NOTES.

**18' CHAIN LINK GATE  
DETAIL 2**  
NTS TYP

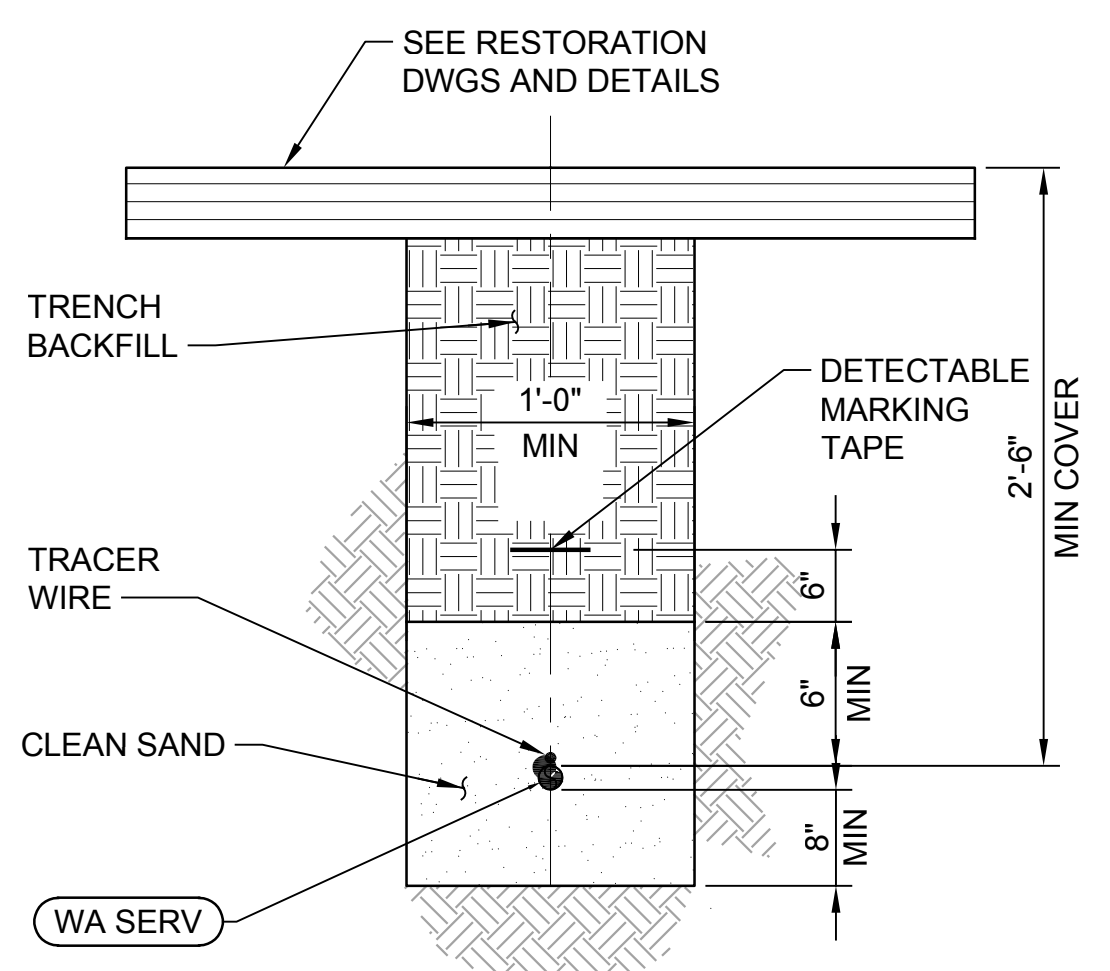

**TRENCH SECTION -  
WATER SERVICE LINE  
DETAIL 3**  
NTS TYP

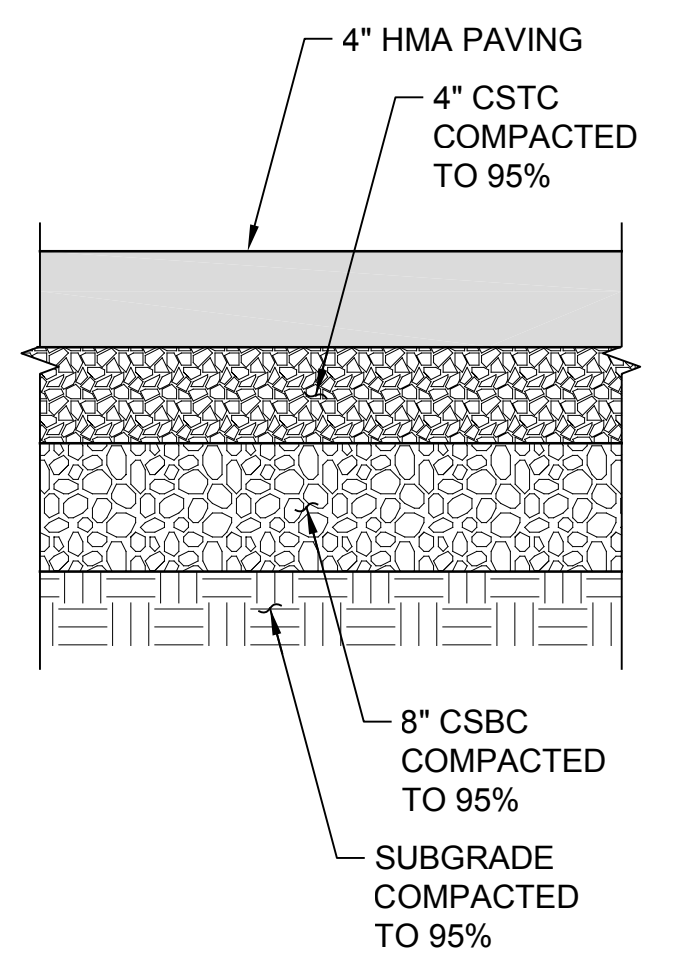

**HMA DRIVEWAY APRON  
DETAIL 4**  
NTS TYP

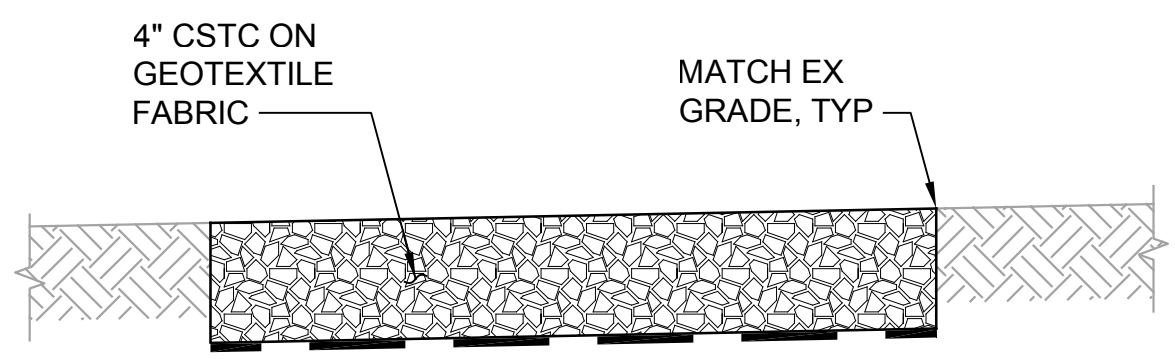

**CSTC RESTORATION  
DETAIL 5**  
NTS TYP

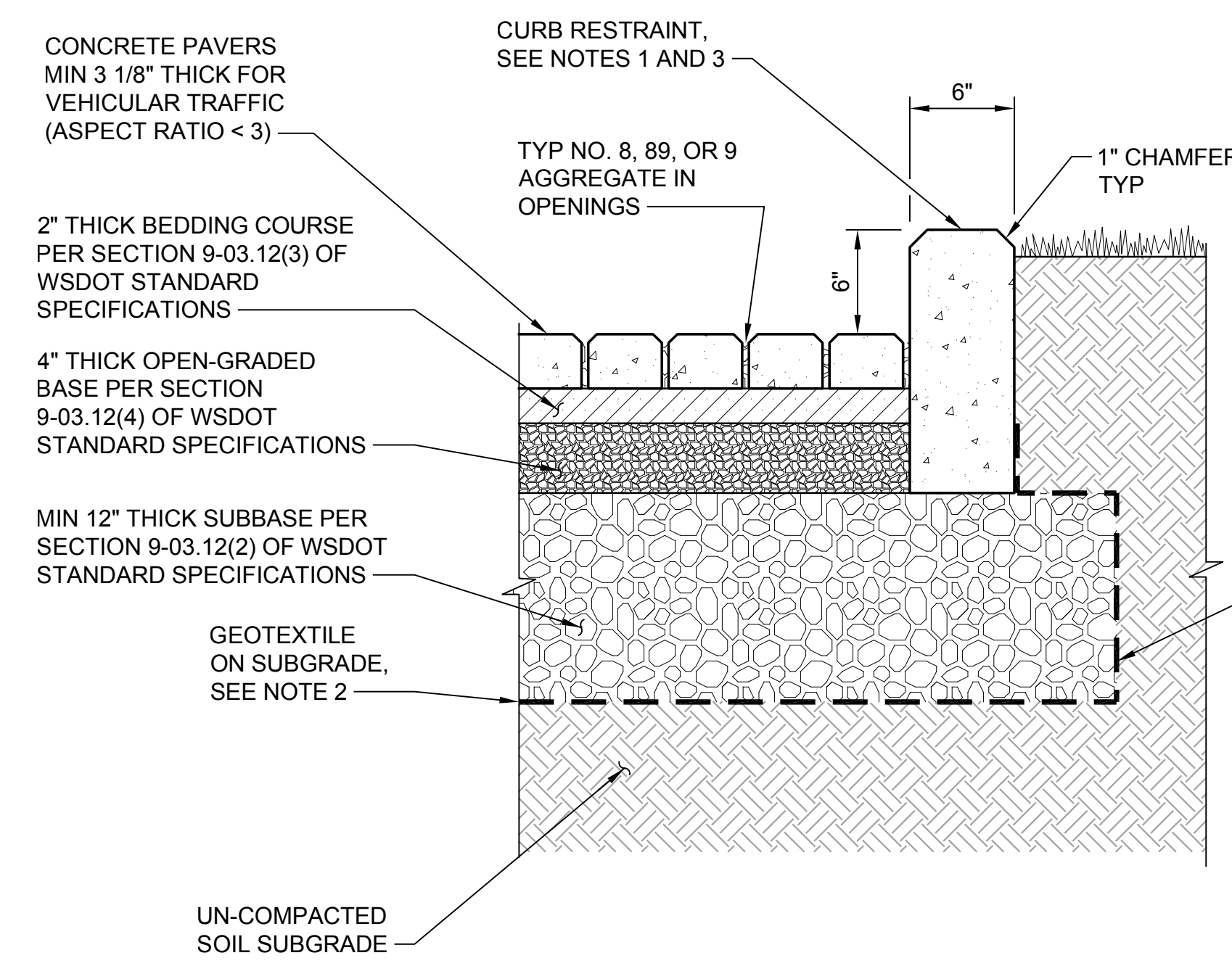

**PICP DRIVEWAY  
DETAIL 6**  
NTS C-1C

- NOTES:**
- INSTALL CONCRETE CURB AROUND ENTIRE PERIMETER OF PICP EXCEPT WHERE PICP ABUTS THE RETAINING WALL. SEE DWG C-7D FOR NOTES REGARDING HEIGHT OF CURB ACROSS ACCESS DRIVEWAYS.
  - GEOTEXTILE PER AASHTO M 288, CLASS 2 SEPARATION.
  - INSTALL CURB EXPANSION JOINTS PER WSDOT STANDARD PLAN F-30.10.

**Call 48 Hours  
Before You Dig**  
1-800-424-5555  
UNDERGROUND SERVICE

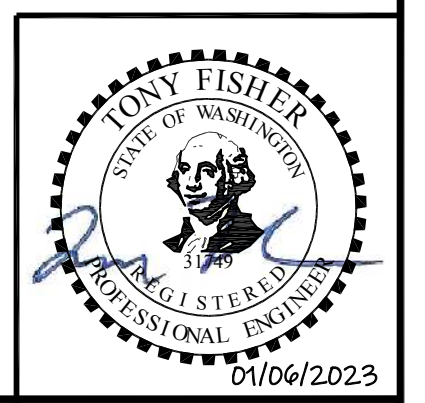

Path: S:\Cadd\Kitsap County\21-10530 Silverdale Conveyance-PS 4 Uprgr\Design\Drawings\21-10530\_C-6 Plot date: Jan 06, 2023 02:30:53pm CAD User: soisee  
Xref Filename: 21-10530\_TB | Fisher | Dan | Palmieri |

No.	Revision	Date	By	App'd
	ISSUED FOR BID	01-2023	TF	RAD

**bhc** CONSULTANTS  
BHC Consultants, LLC  
1601 Fifth Avenue, Suite 500  
Seattle, Washington 98101  
206.505.3400  
206.505.3406 (fax)  
www.bhcconsultants.com

Designed: T. Fisher, P.E.  
Drawn: P. Simon  
Checked: R. Dorn, P.E.

Scale:  
NTS  
One Inch at Full Scale  
If Not One Inch  
Scale Accordingly



**Kitsap County Public Works**  
614 Division Street, MS 26  
Port Orchard, WA 98366

**SILVERDALE CONVEYANCE SYSTEM AND PUMP STATION 4 UPGRADES**

**CIVIL DETAILS  
1 OF 4**

Drawing: **C-6**  
Sheet: **11** of **117**  
File: P21-10530\_C-6  
Date: January 2023

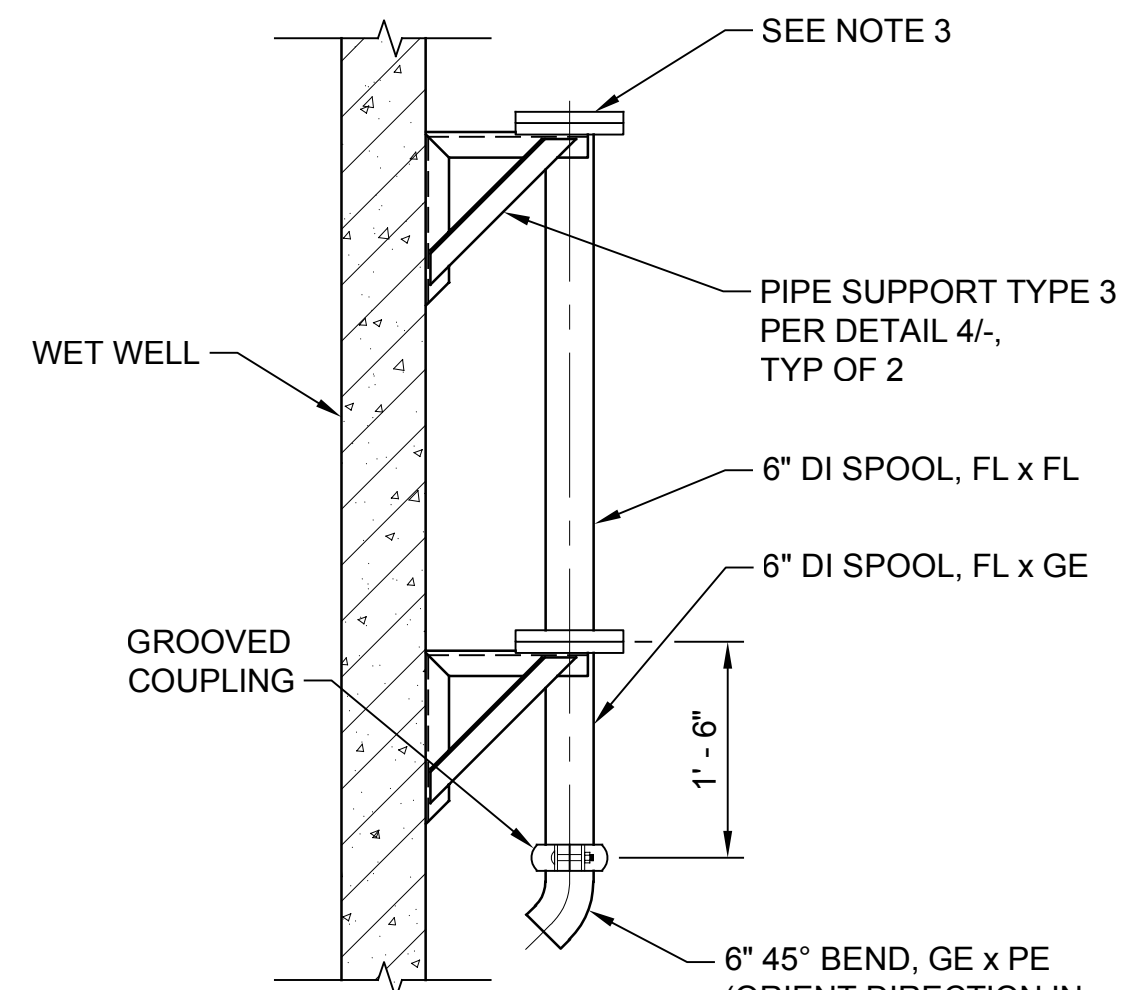

- NOTES:**
1. LOCATE TO AVOID CONFLICT WITH WET WELL APPURTENANCES.
  2. TERMINATE 45° BEND AT 12" ABOVE GROUT FILLET.
  3. SEE PLAN AND SECTION VIEW DRAWINGS FOR THE FITTINGS THAT ARE CONNECTED TO BACK FLUSH PIPE.

**BACKFLUSH PIPE  
DETAIL**  
NTS TYP

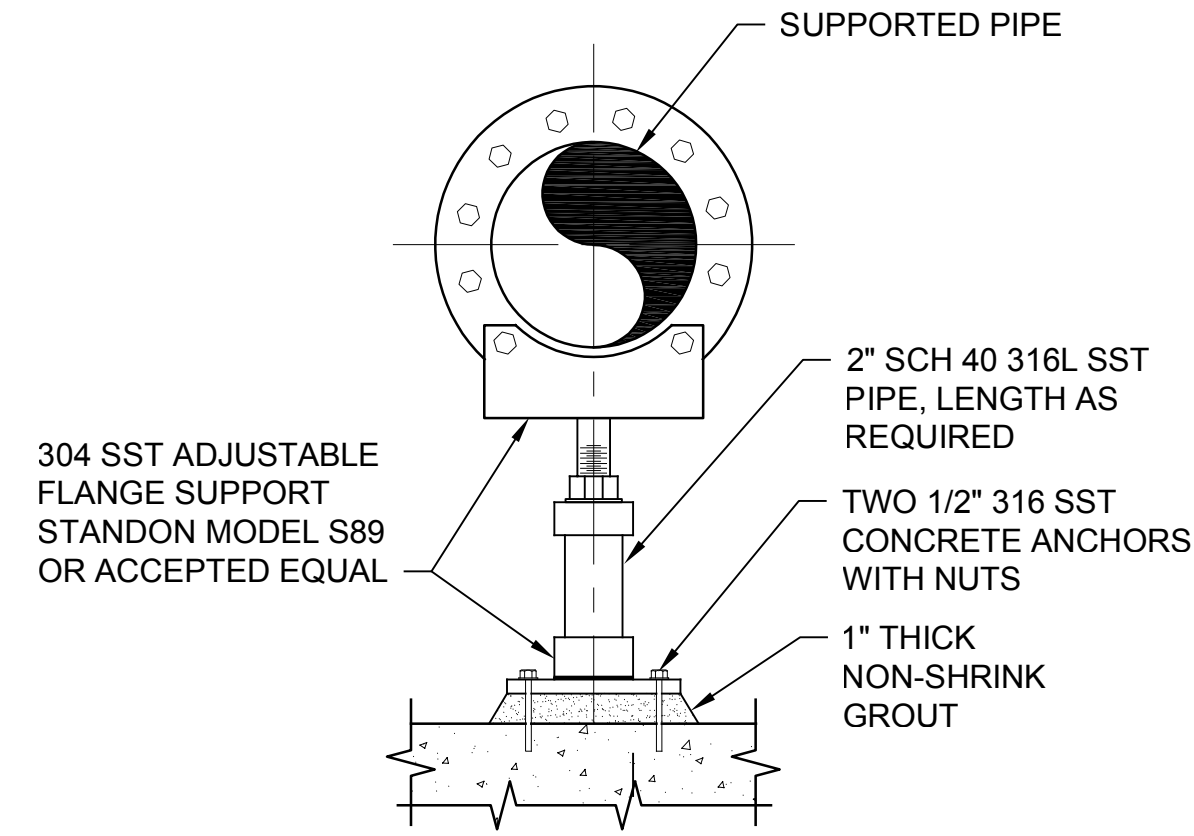

- NOTES:**
1. TO ENSURE PROPER SUPPORT AND STABILITY, AFTER FINAL HEIGHT ADJUSTMENT IS ATTAINED, APPLY 3/16" TACK WELDS TO BOTH SUPPORT CUPS AND EXTENSION PIPE.

**PIPE SUPPORT TYPE 1  
DETAIL**  
NTS TYP

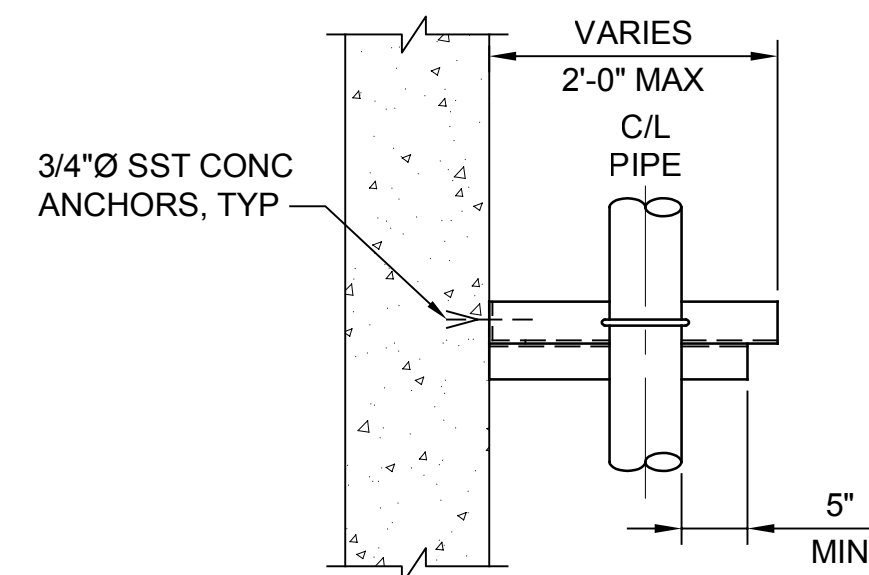

- NOTE:**
1. ALL SUPPORT MATERIAL TO BE TYPE 316L STAINLESS STEEL. ALL FASTENERS (NUTS, BOLTS, ANCHORS, WASHERS, ETC.) SHALL BE TYPE 316 OR 316L STAINLESS STEEL.

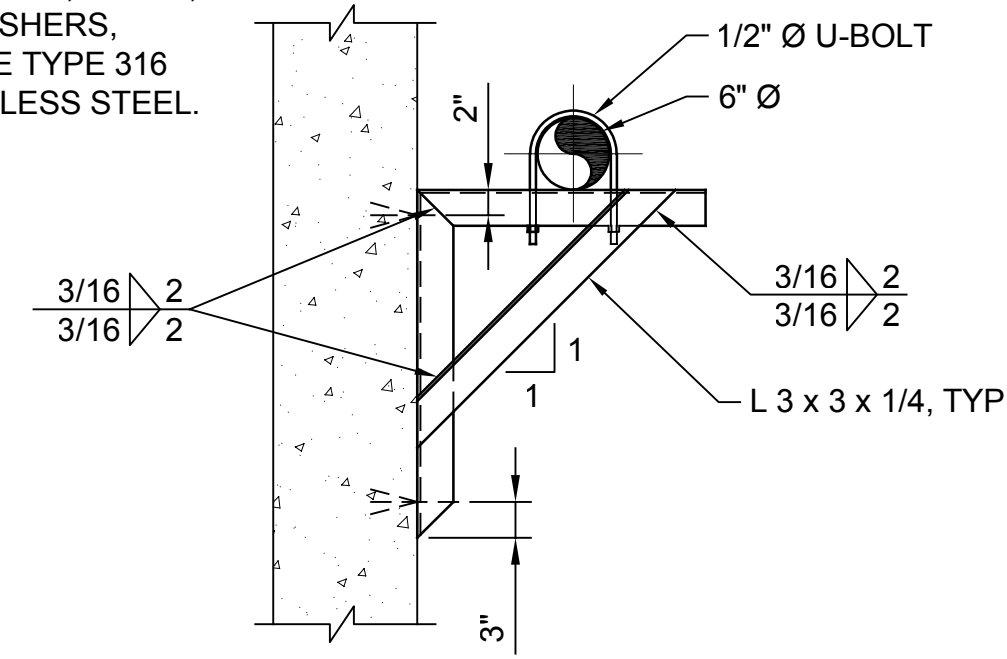

**PIPE SUPPORT TYPE 2  
DETAIL**  
NTS TYP

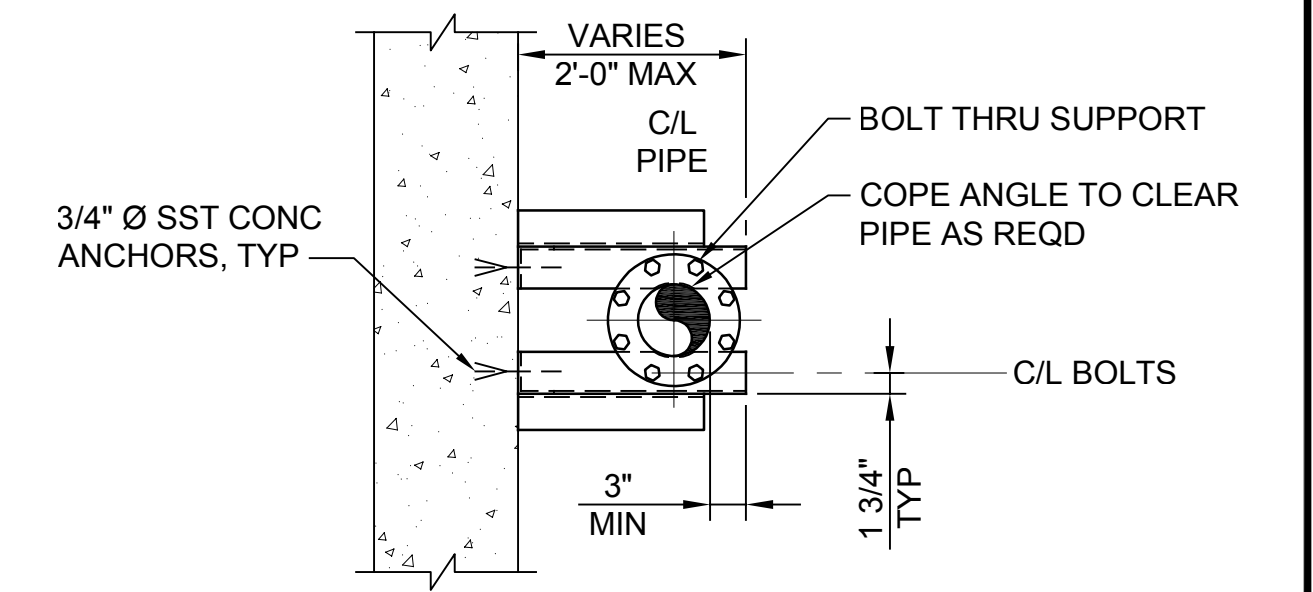

- NOTE:**
1. ALL SUPPORT MATERIAL TO BE TYPE 316L STAINLESS STEEL. ALL FASTENERS (NUTS, BOLTS, ANCHORS, WASHERS, ETC.) SHALL BE TYPE 316 OR 316L STAINLESS STEEL.

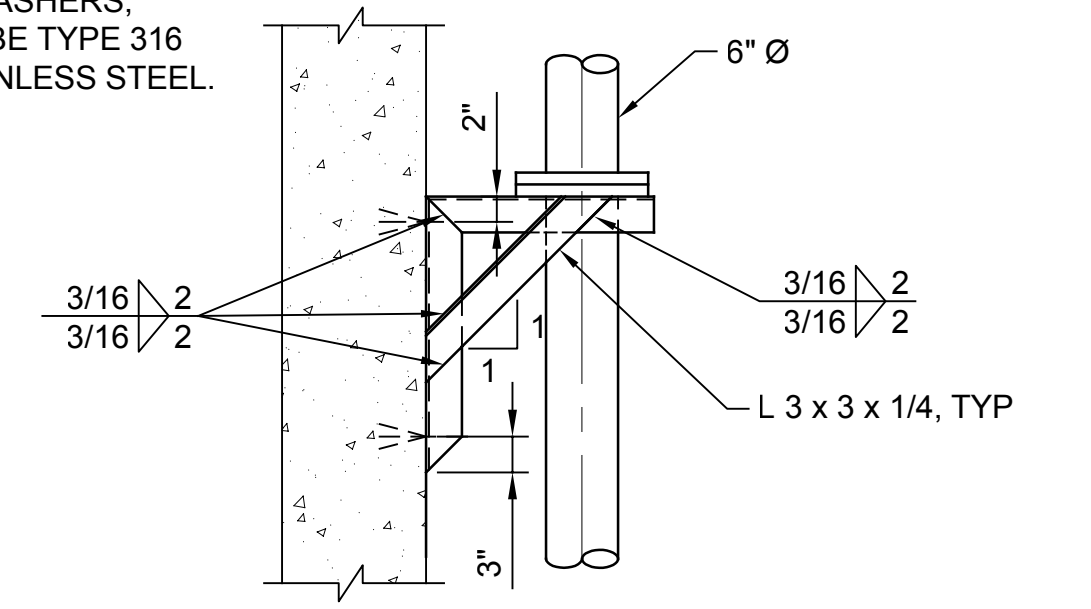

**PIPE SUPPORT TYPE 3  
DETAIL**  
NTS TYP

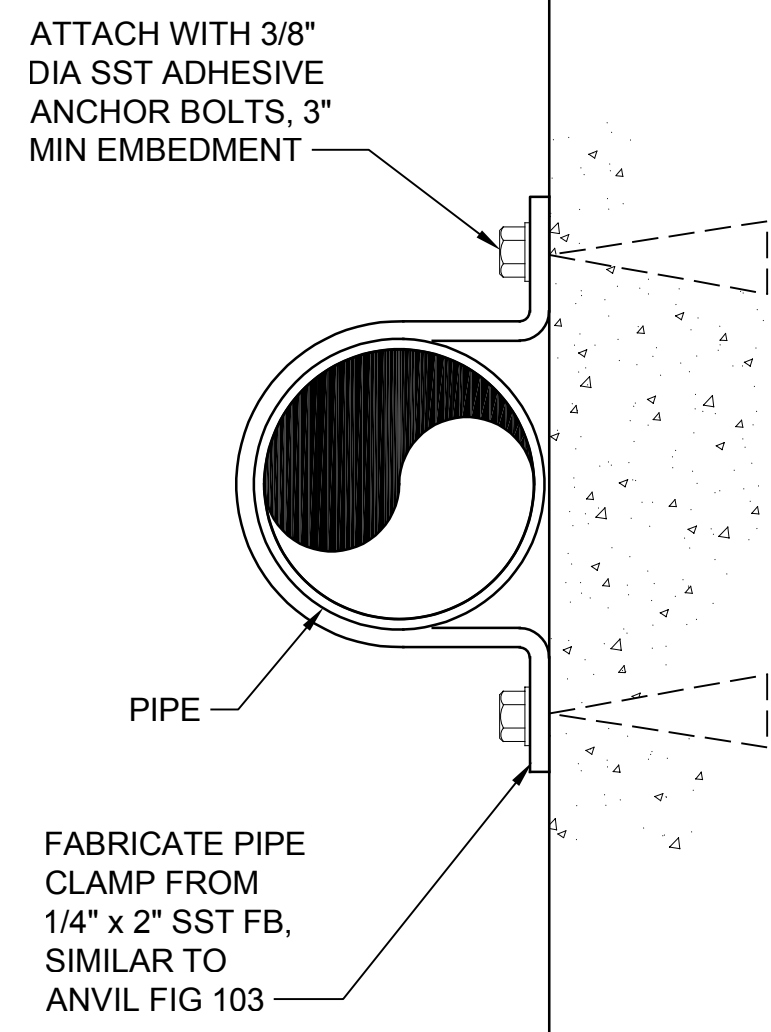

- NOTE:**
1. ALL SUPPORT MATERIAL TO BE TYPE 316L STAINLESS STEEL. ALL FASTENERS (NUTS, BOLTS, ANCHORS, WASHERS, ETC.) SHALL BE TYPE 316 OR 316L STAINLESS STEEL.

**PIPE SUPPORT TYPE 4  
DETAIL**  
NTS TYP

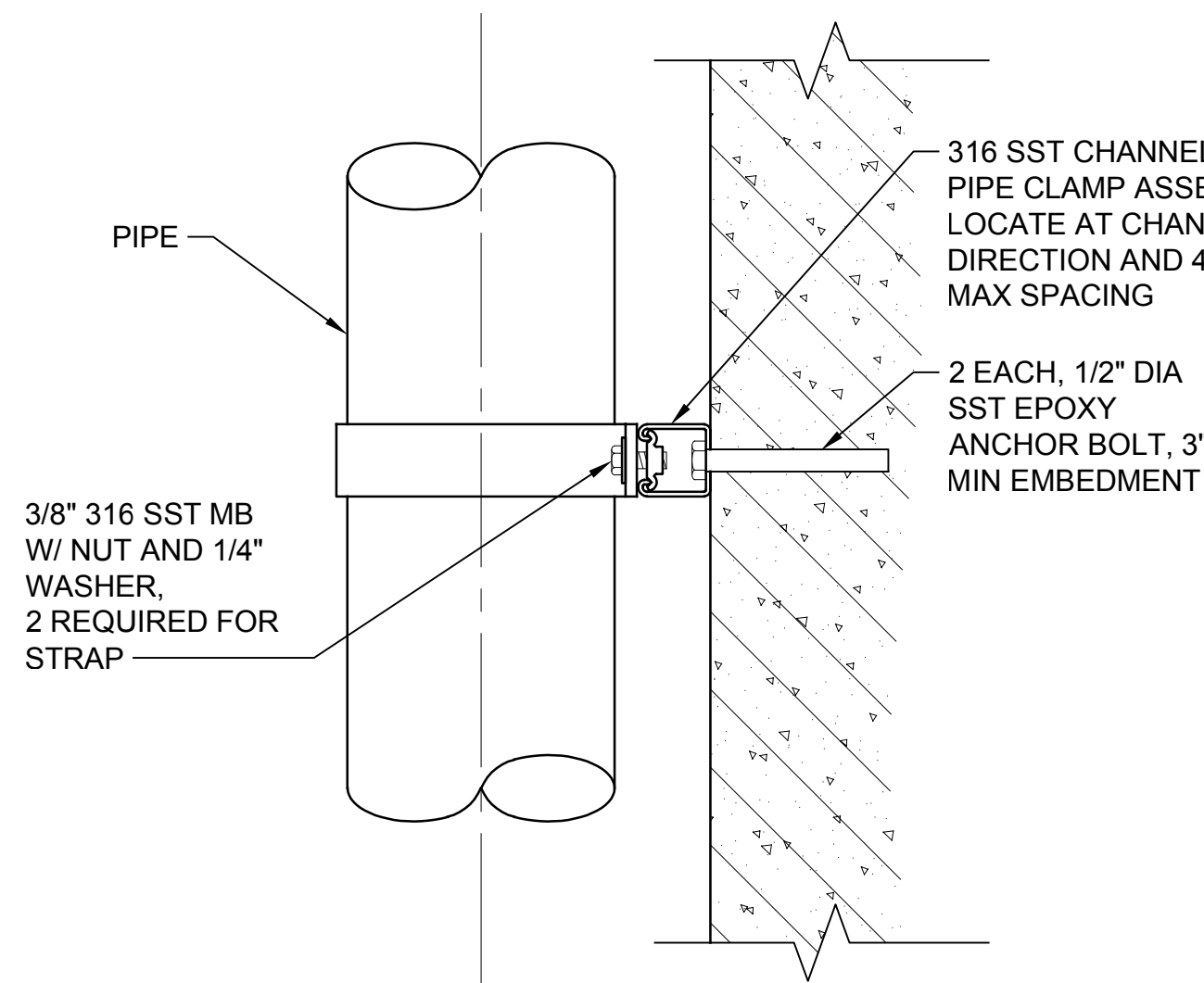

- NOTE:**
1. ALL SUPPORT MATERIAL TO BE TYPE 316L STAINLESS STEEL. ALL FASTENERS (NUTS, BOLTS, ANCHORS, WASHERS, ETC.) SHALL BE TYPE 316 OR 316L STAINLESS STEEL.

**PIPE SUPPORT TYPE 5  
DETAIL**  
NTS TYP

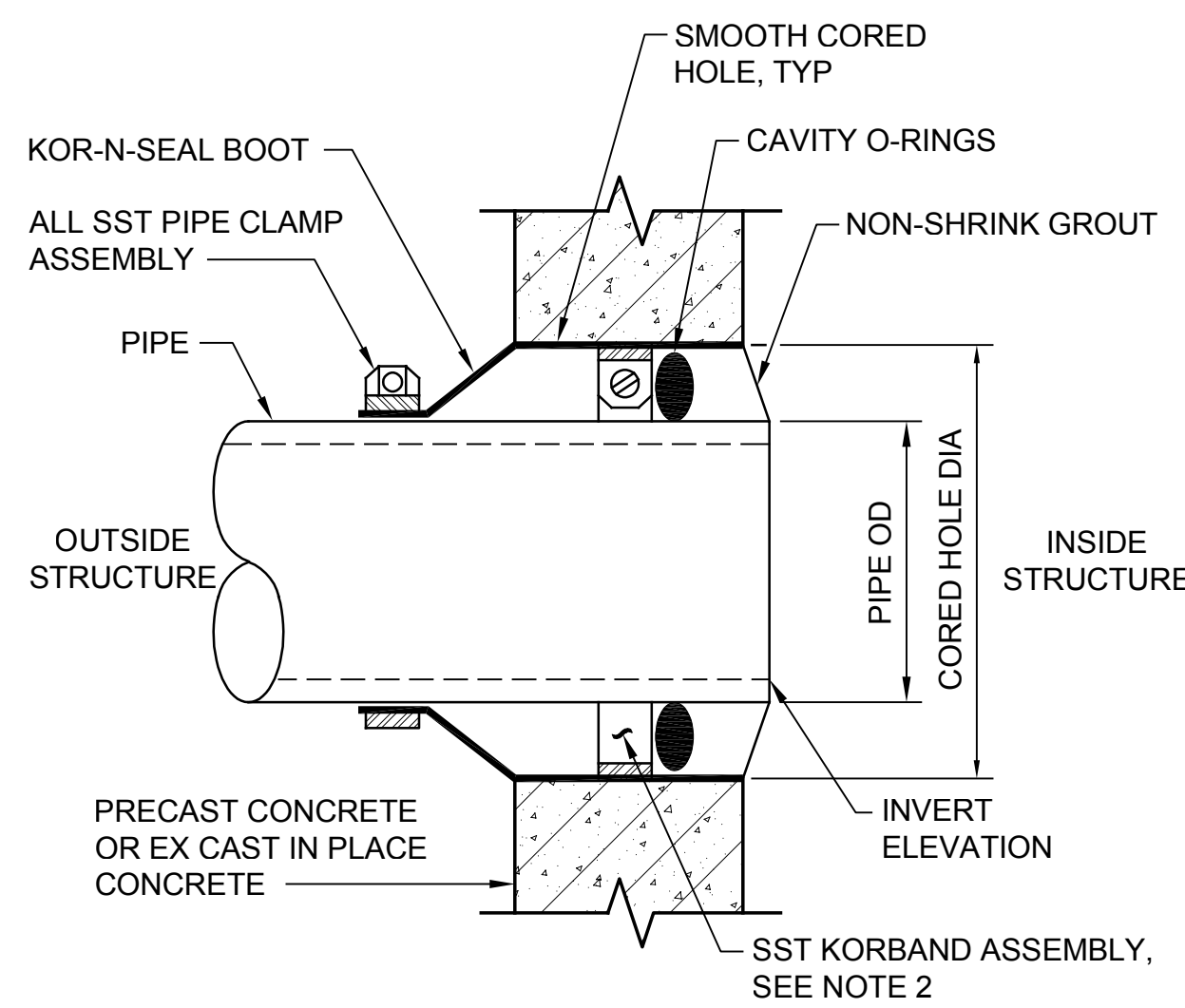

- NOTES:**
1. CONTRACTOR SHALL COORDINATE CORED HOLE DIAMETER REQUIREMENTS WITH PIPING AND MANHOLE/VAULT MANUFACTURER.
  2. FOR PENETRATION INTO EXISTING MANHOLES, WET WELLS, OR VAULTS, KORBAND ASSEMBLY SHALL CONSIST OF 316 STAINLESS STEEL WEDGES.

**WALL PENETRATION TYPE 1  
DETAIL**  
NTS TYP

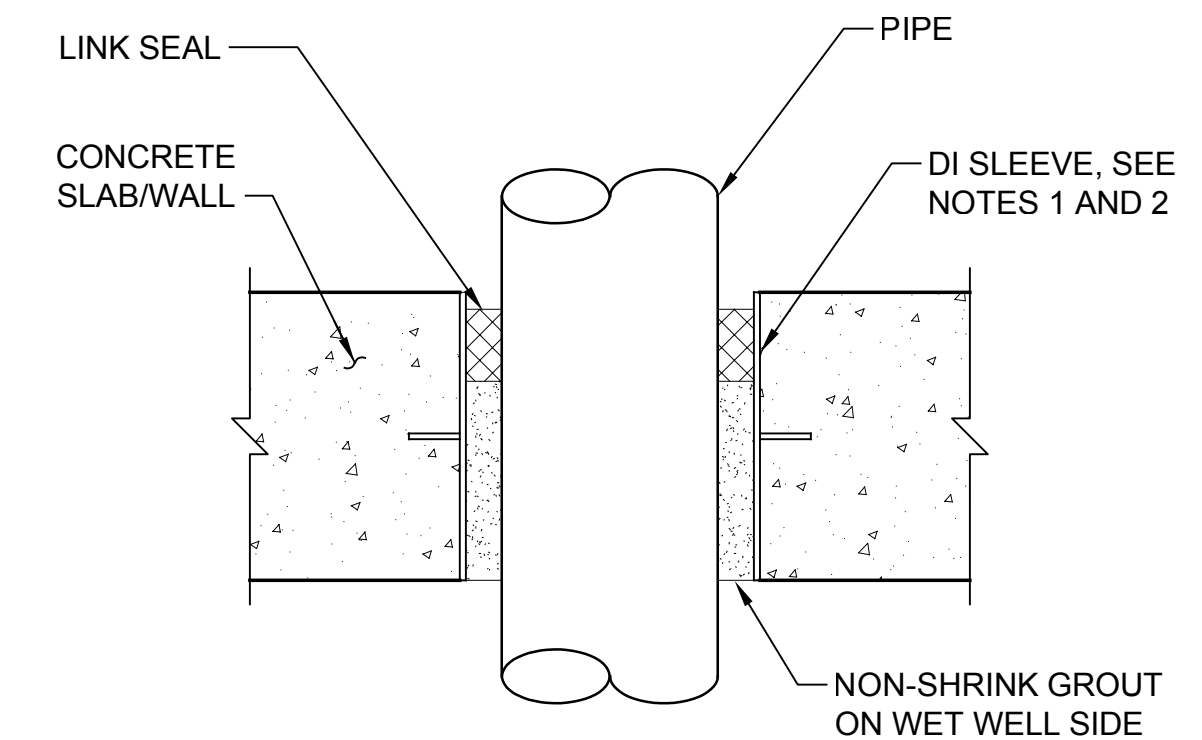

- NOTES:**
1. CORE EXISTING CONCRETE SLABS OR WALLS AT LEAST 2 INCHES IN DIAMETER LARGER THAN PIPE AND INSTALL LINK SEALS IN ANNULAR SPACE. WALL SLEEVE IS NOT REQUIRED FOR CORED HOLES.
  2. FOR NEW SLABS OR WALLS, INSTALL WALL SLEEVE AS PART OF FORMS PRIOR TO POURING CONCRETE. INSTALL LINK SEALS IN ANNULAR SPACE BETWEEN WALL SLEEVE AND PIPE.

**WALL/FLOOR PENETRATION TYPE 2  
DETAIL**  
NTS TYP

Path: S:\Cadd\Kitsap County\21-10530 Silverdale Convey-PS 4 Uprgt\Design\Drawings\21-10530\_C-7.dwg Plot date: Jan 06, 2023 02:40:56pm CAD User: soisee  
Xref Filename: 1\21-10530\_TB\Fisher\Dan\Palmer1.rvt

No.	Revision	Date	By	App'd
	ISSUED FOR BID	01-2023	TF	RAD

**bhc**  
CONSULTANTS

**BHC Consultants, LLC**  
1601 Fifth Avenue, Suite 500  
Seattle, Washington 98101  
206.505.3400  
206.505.3406 (fax)  
www.bhcconsultants.com

Designed: T. Fisher, P.E.  
Drawn: P. Simon  
Checked: R. Dorn, P.E.

Scale:  
NTS  
One Inch at Full Scale  
If Not One Inch  
Scale Accordingly



**Kitsap County Public Works**  
614 Division Street, MS 26  
Port Orchard, WA 98366

**SILVERDALE CONVEYANCE SYSTEM AND PUMP STATION 4 UPGRADES**

**CIVIL DETAILS  
2 OF 4**

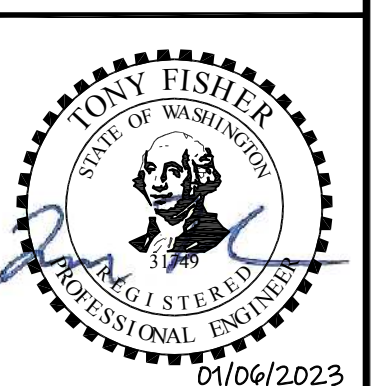

**Call 48 Hours  
Before You Dig**  
1-800-424-5555  
UNDERGROUND SERVICE

Drawing: **C-7**  
Sheet: **12** of **117**  
File: P21-10530\_C-7  
Date: January 2023

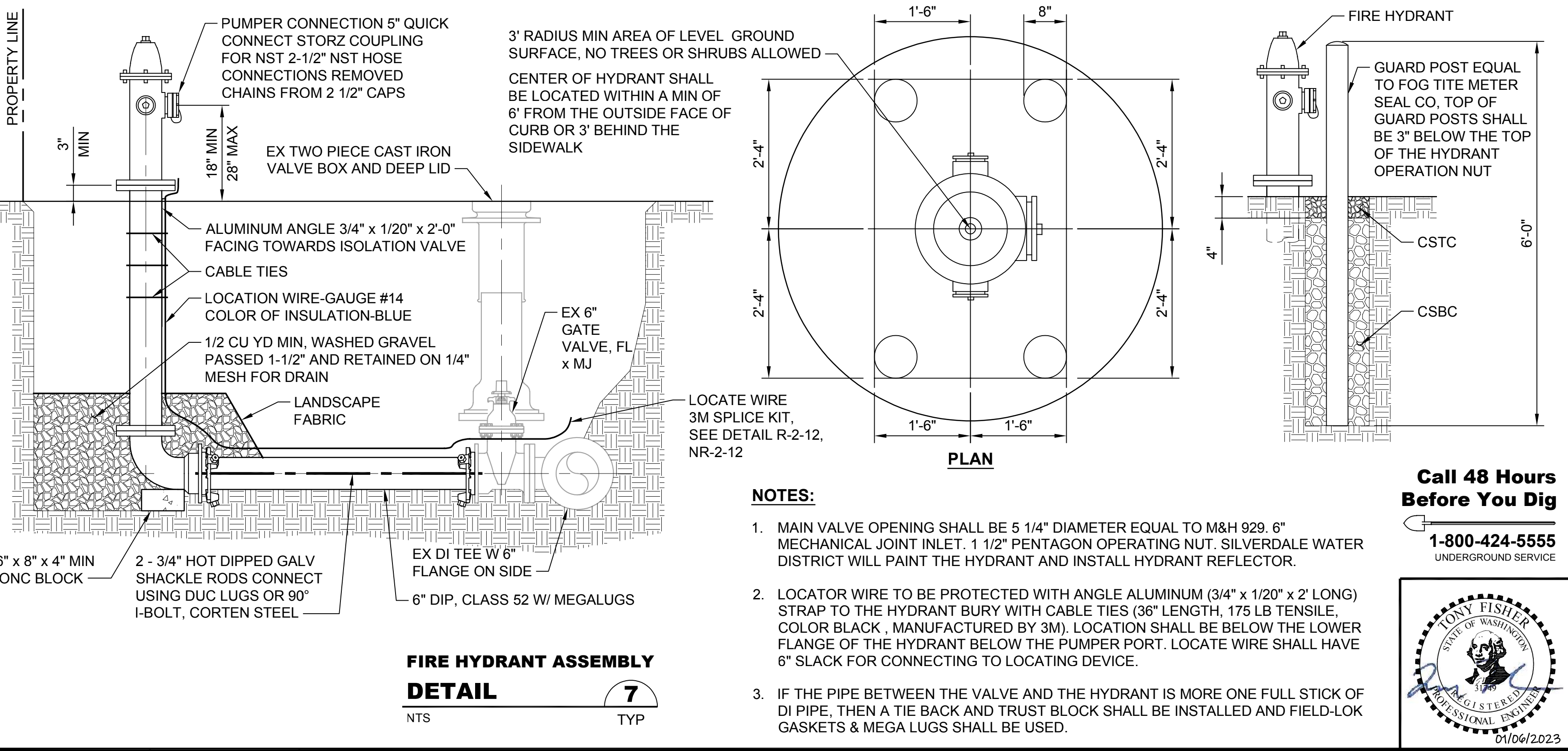
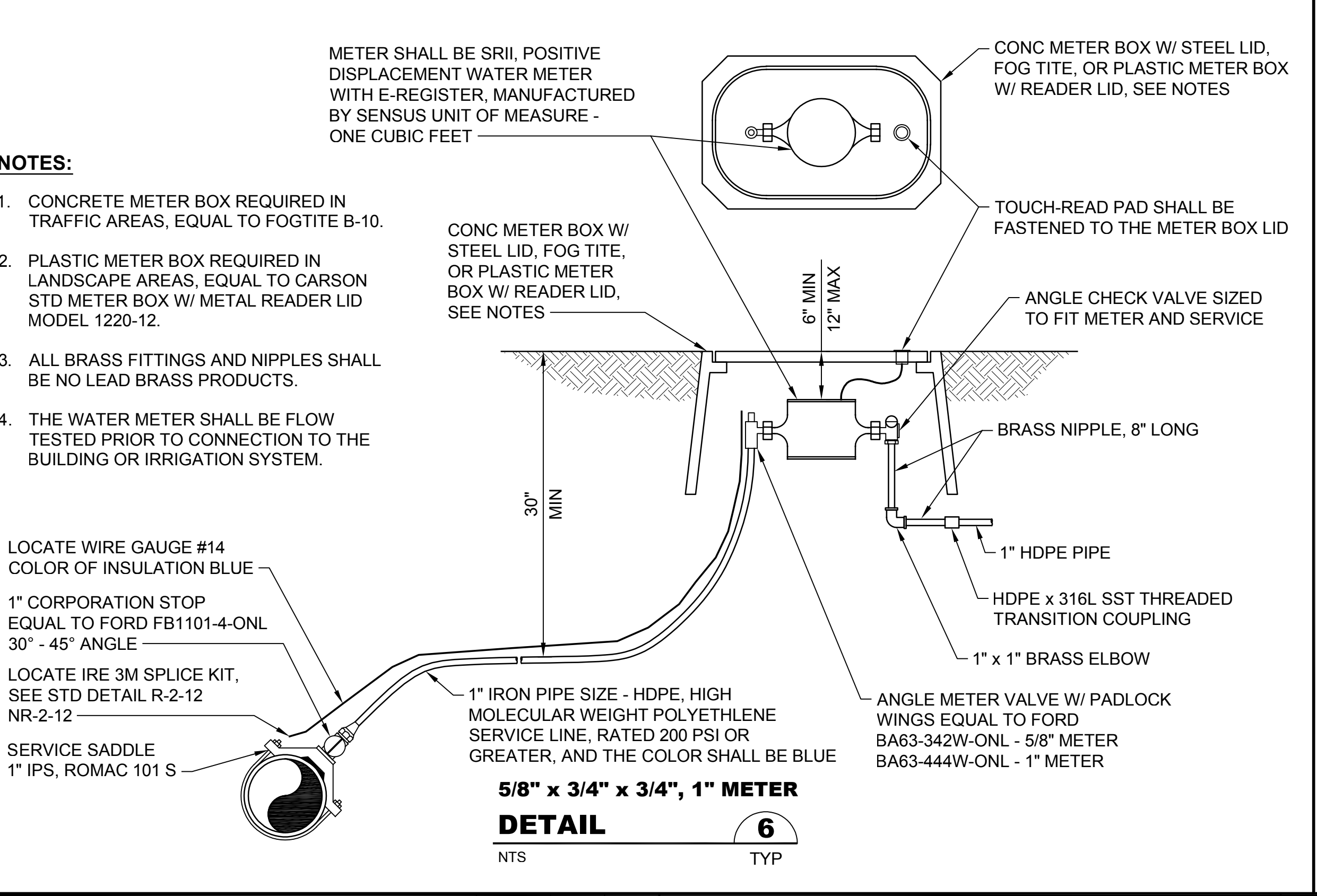
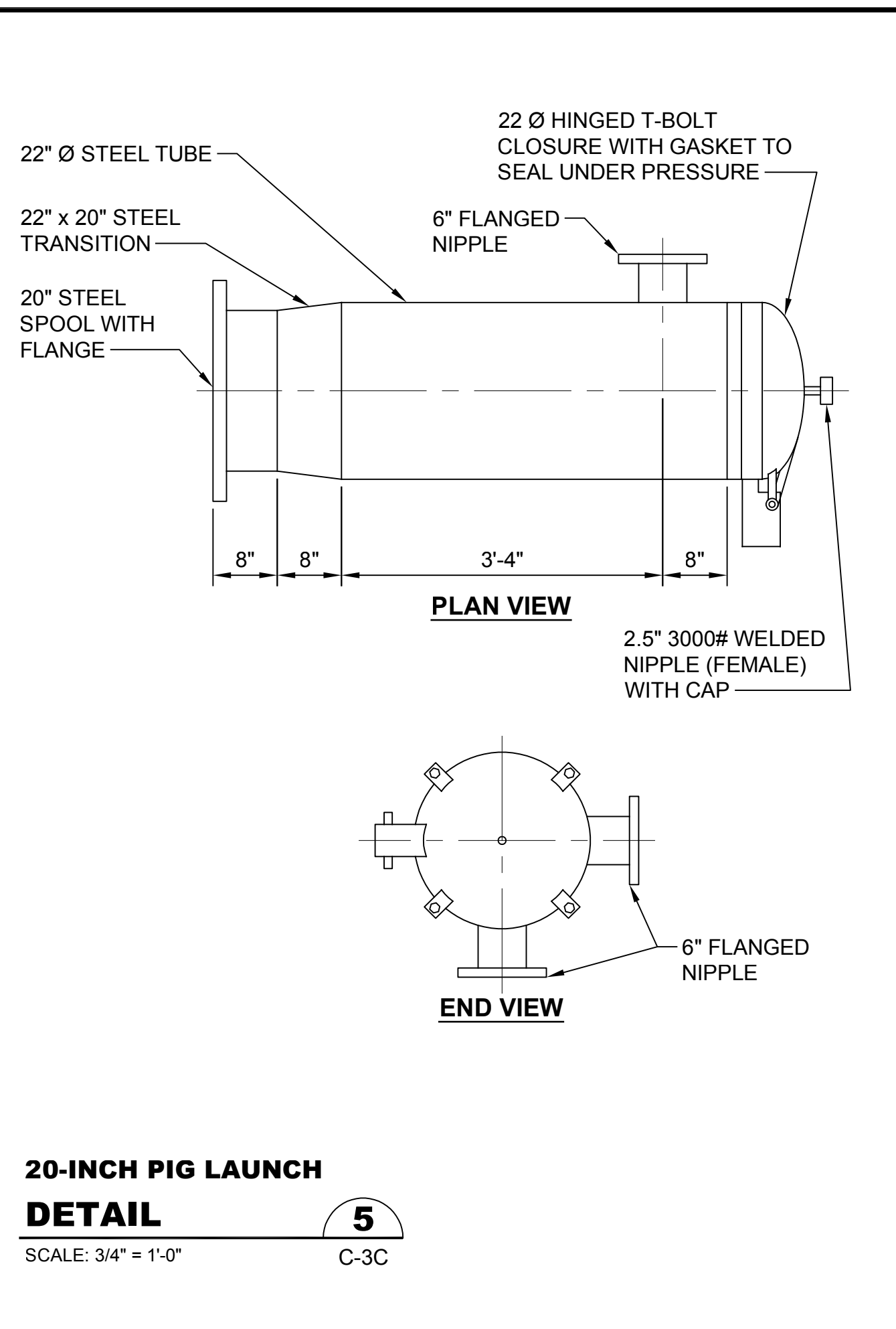
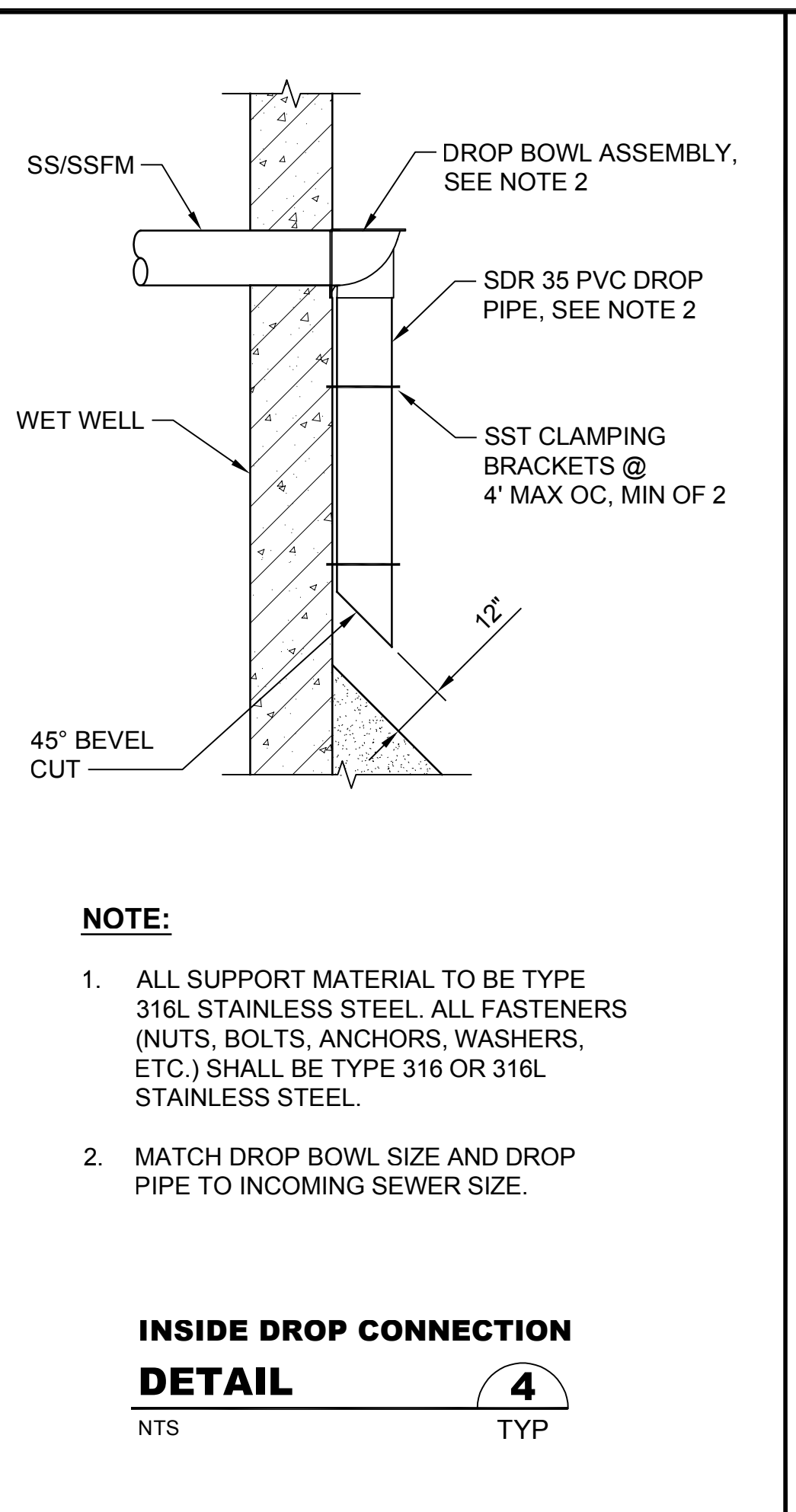
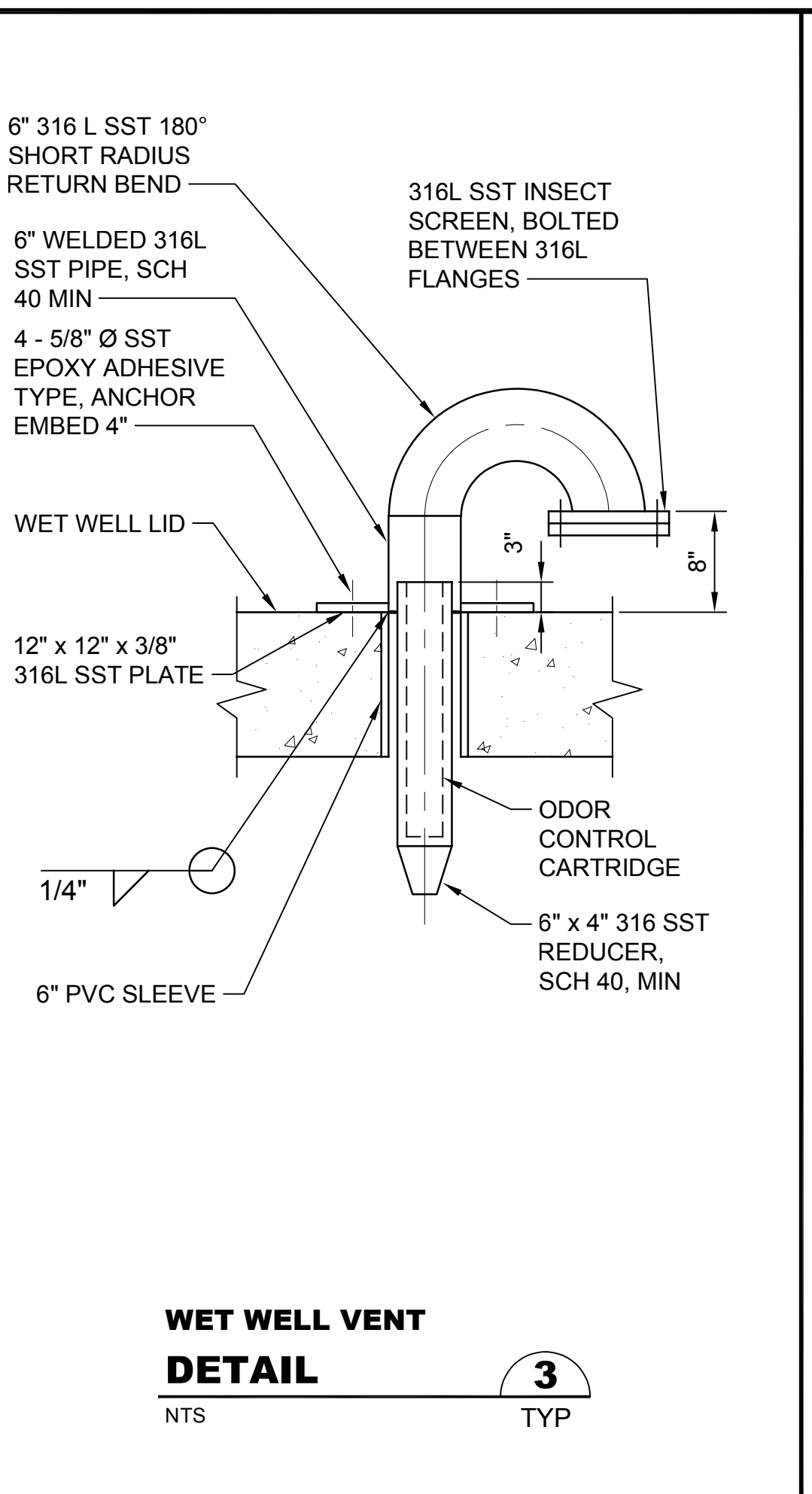
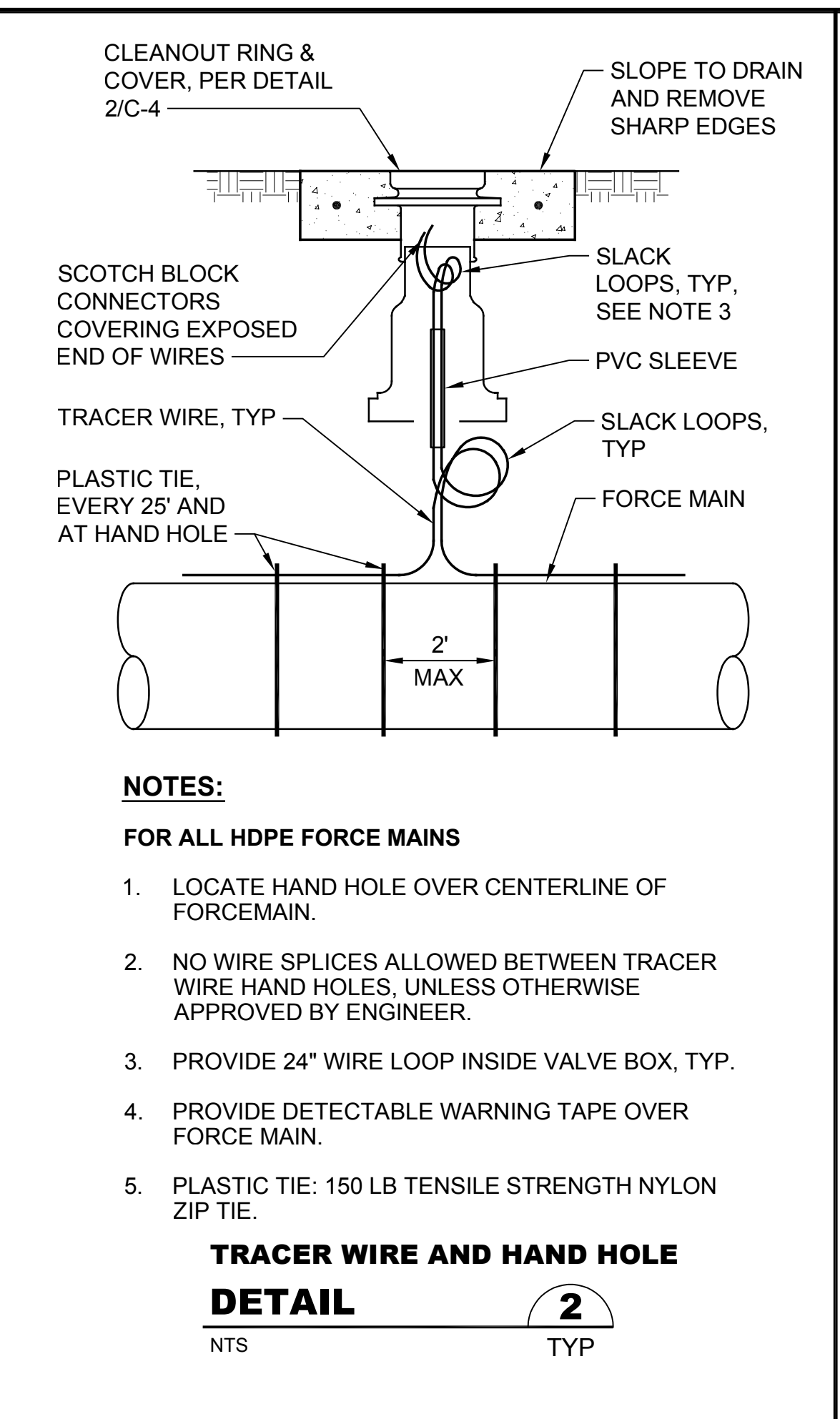
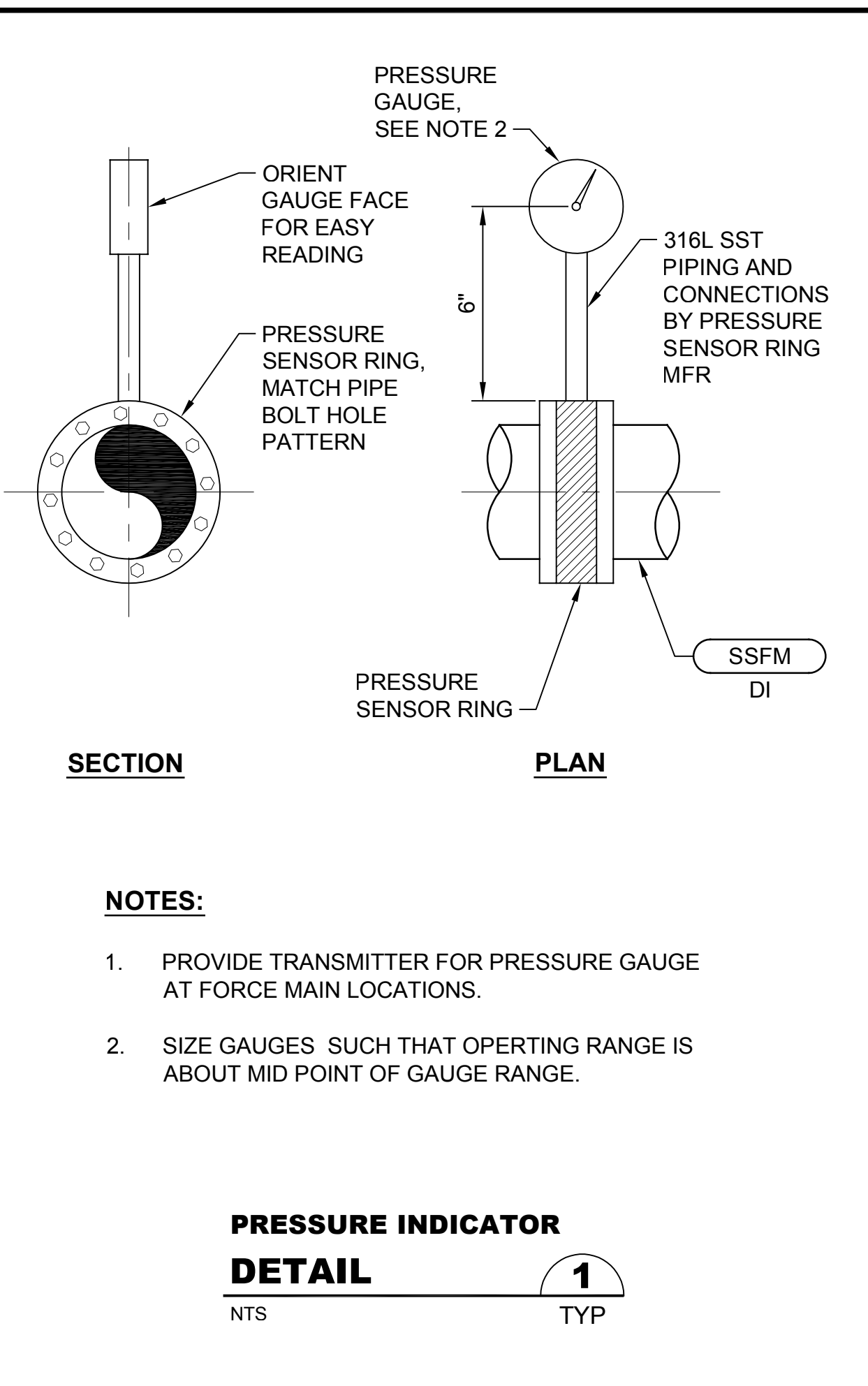

Path: S:\Cadd\Kitsap County\21-10530 Silverdale Conveyance-PS 4 Uprgr\Design\Drawings\21-10530\_C-8 Plot date: Jan 06, 2023 05:41:09pm CAD User: soisee  
 Xref Filename: 21-10530\_TB1\Fisher\Dan\1\Final.dwg

No.	Revision	Date	By	App'd
	ISSUED FOR BID	01-2023	TF	RAD

**bhc CONSULTANTS**

**BHC Consultants, LLC**  
1601 Fifth Avenue, Suite 500  
Seattle, Washington 98101  
206.505.3400  
206.505.3406 (fax)  
www.bhcconsultants.com

Designed: T. Fisher, P.E.	Scale: As Shown
Drawn: P. Simon	One Inch at Full Scale If Not One Inch Scale Accordingly
Checked: R. Dorn, P.E.	

**Kitsap County Public Works**  
614 Division Street, MS 26  
Port Orchard, WA 98366

**SILVERDALE CONVEYANCE SYSTEM AND PUMP STATION 4 UPGRADES**

**CIVIL DETAILS 3 OF 4**

Drawing: **C-8**  
Sheet: **13** of **117**  
File: P21-10530\_C-8  
Date: January 2023

**Call 48 Hours Before You Dig**  
1-800-424-5555  
UNDERGROUND SERVICE

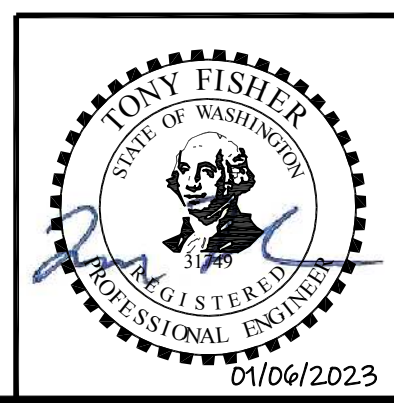

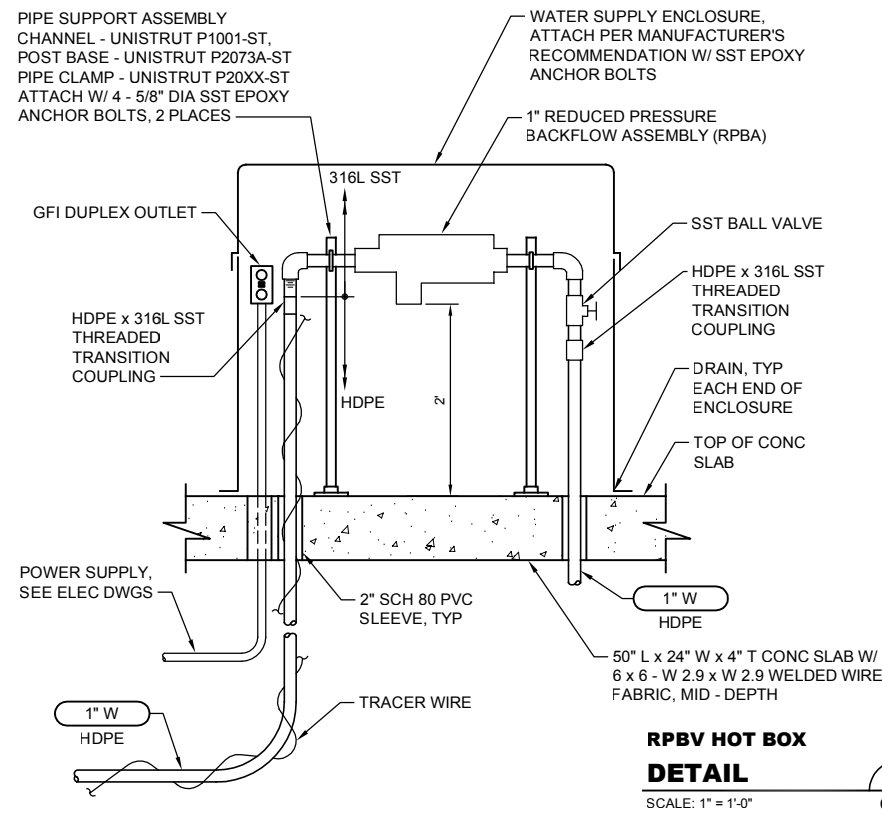
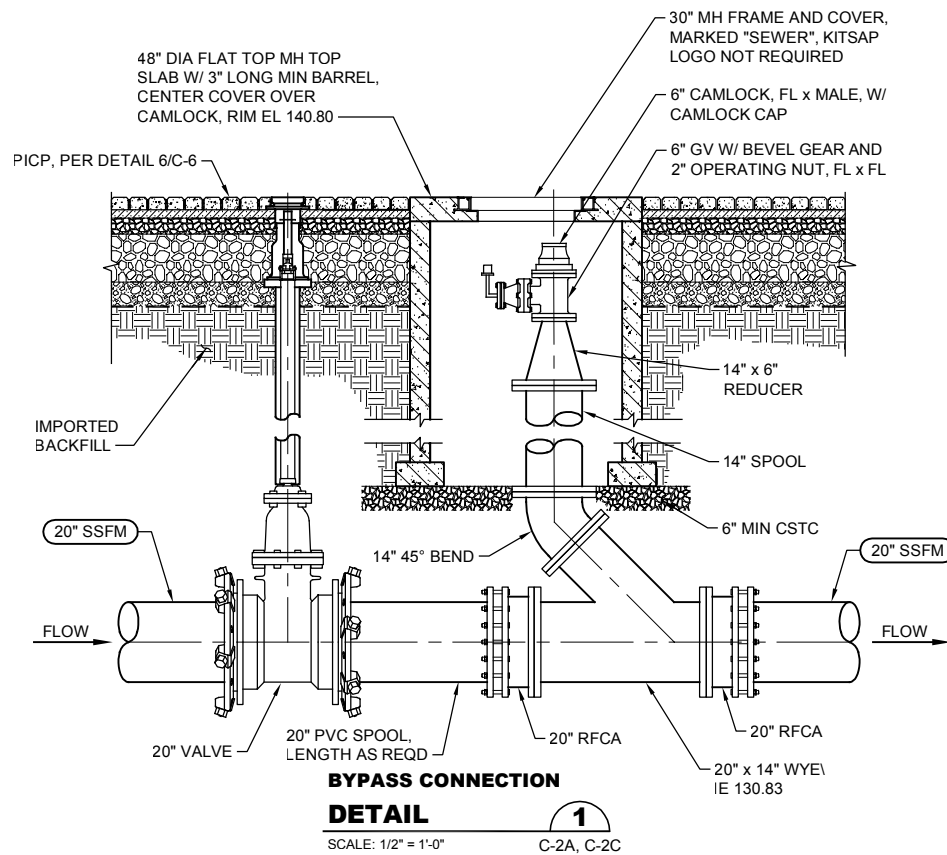

- NOTES:**
- ALL PIPE AND FITTINGS SHALL BE TYPE 316L STAINLESS STEEL, EXCEPT AS NOTED.
  - ATTACH SIGN TO INSIDE OF WATER SUPPLY ENCLOSURE STATING "CAUTION NON-POTABLE WATER DO NOT DRINK".
  - MAINTAIN 6" MIN CLEARANCE BETWEEN WATER PIPE/FIXTURES AND FACE OF ENCLOSURE.
  - SEE CIVIL DWGS FOR ACTUAL ORIENTATION OF ENCLOSURE AND PIPING ON SLAB.
  - APPLY HEATING CABLE, PROVIDED WITH THE WATER SUPPLY ENCLOSURE, TO PIPE AS RECOMMENDED BY WATER SUPPLY ENCLOSURE MANUFACTURER. CONNECT HEATING CABLE TO RECEPTACLE WITHIN ENCLOSURE.

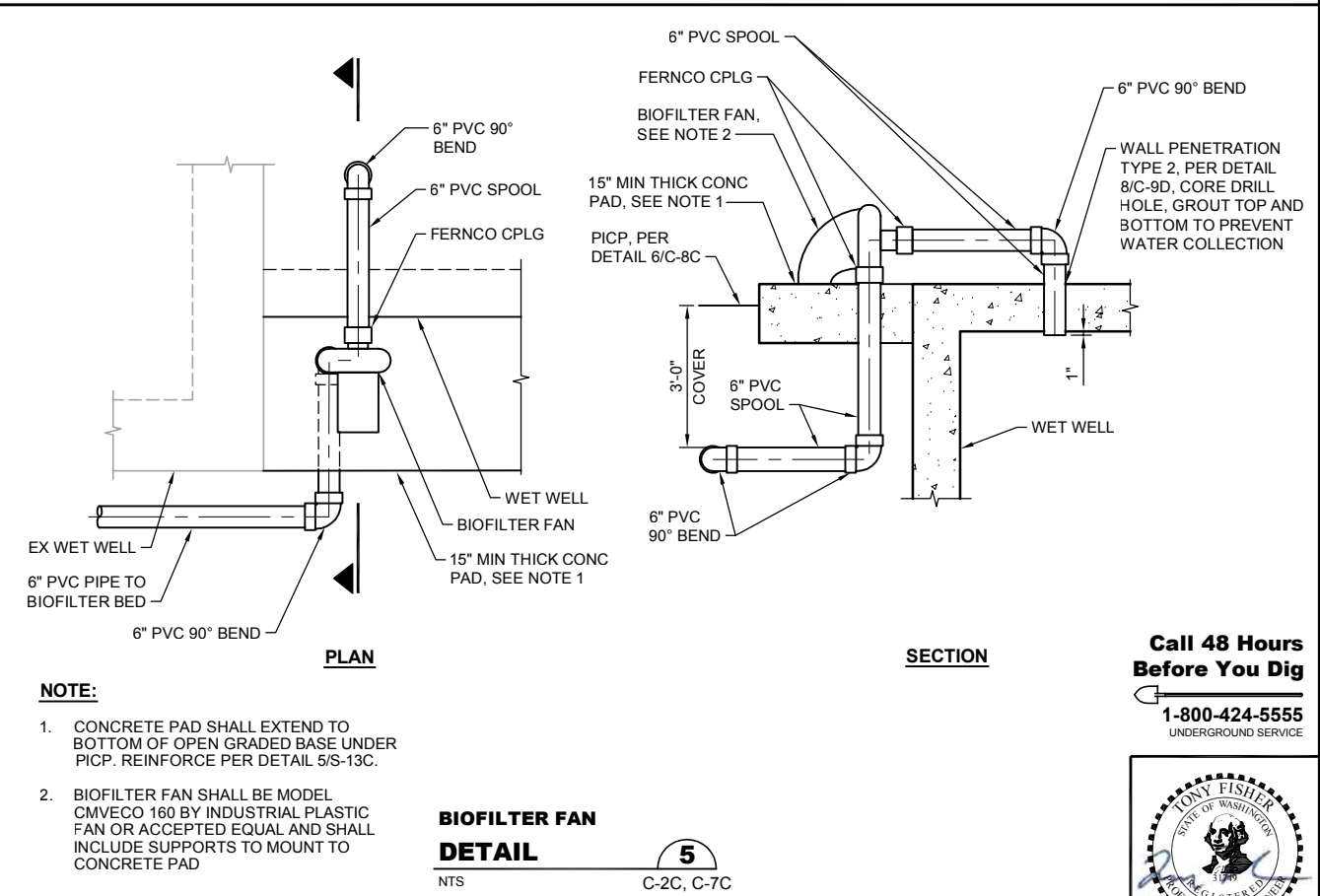
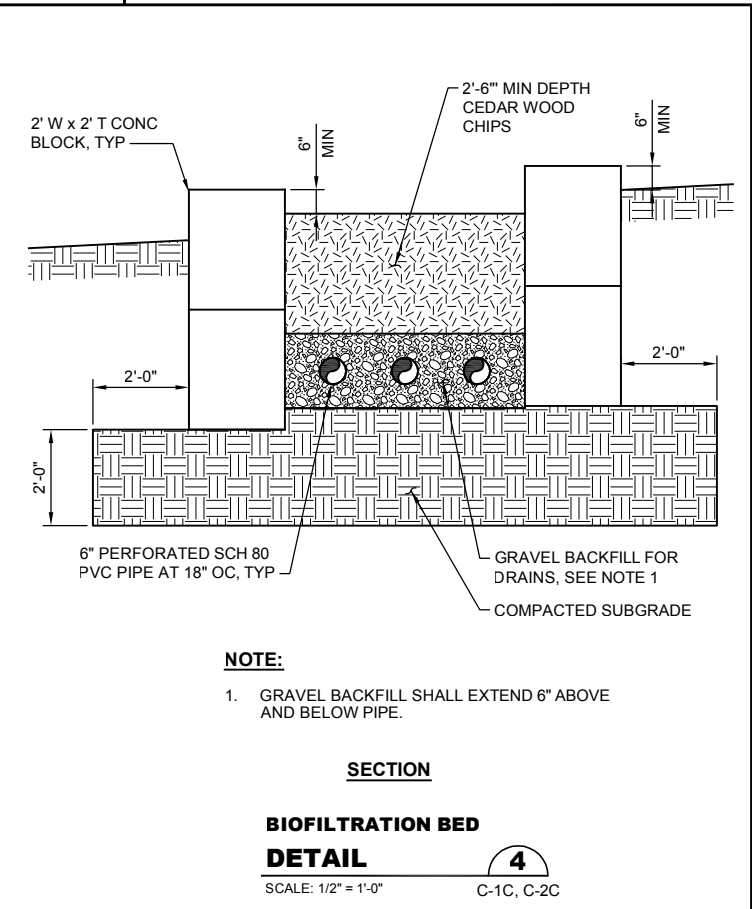
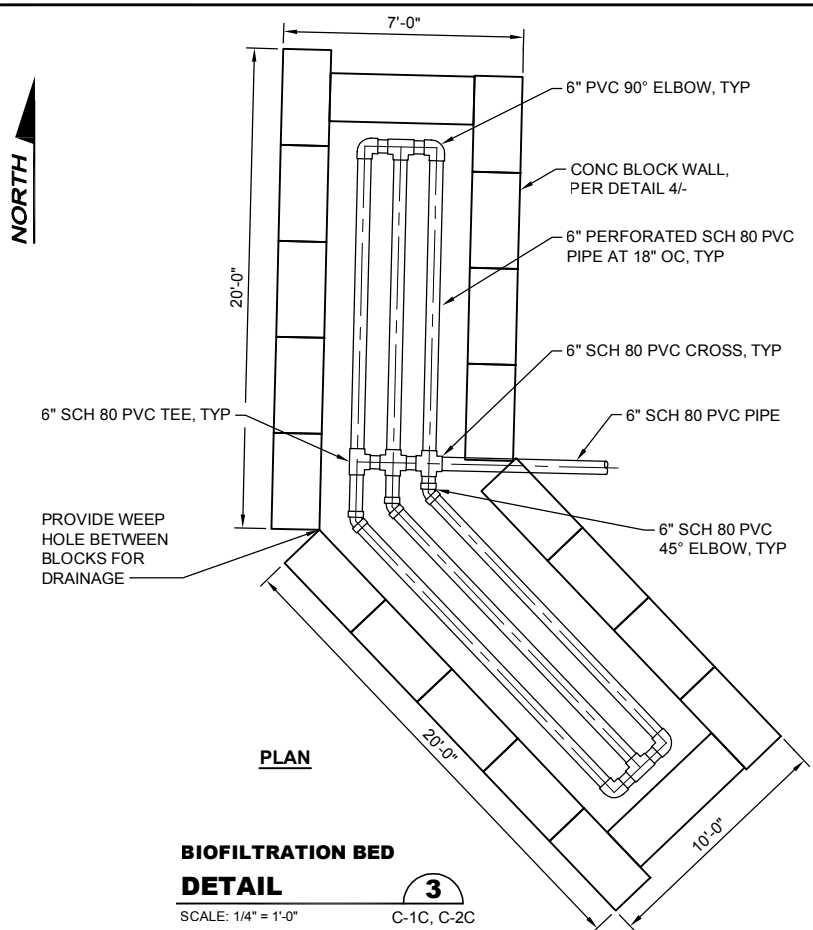

**Call 48 Hours Before You Dig**  
**1-800-424-5555**  
 UNDERGROUND SERVICE



Path: S:\Cadd\Kitsap County\21-10530 Silverdale Conveyance\PS 4 Upgr\Design\Drawings\21-10530-PS4\_TB | Fisher | Dahli | Palmatier | Xref Filename: | X21-10530-PS4\_TB | Date: Mar 20, 2023 02:22:00pm CAD User: solsoe

No.	Revision	Date	By	App'd
	ISSUED FOR BID	01-2023	TF	RAD



**BHC Consultants, LLC**  
 1601 Fifth Avenue, Suite 500  
 Seattle, Washington 98101  
 206.505.3400  
 206.505.3406 (fax)  
 www.bhcconsultants.com

Designed: T. Fisher, P.E.  
 Drawn: A. Cariaso  
 Checked: R. Dorn, P.E.

Scale:  
 As Shown  
 One Inch at Full Scale  
 If Not One Inch Scale Accordingly



**Kitsap County Public Works**  
 614 Division Street, MS 26  
 Port Orchard, WA 98366

**SILVERDALE CONVEYANCE SYSTEM AND PUMP STATION 4 UPGRADES**  
**CIVIL DETAILS**  
**4 OF 4**

Drawing: **C-9**  
 Sheet: **14** of **117**  
 File: P21-10530\_C-9  
 Date: January 2023

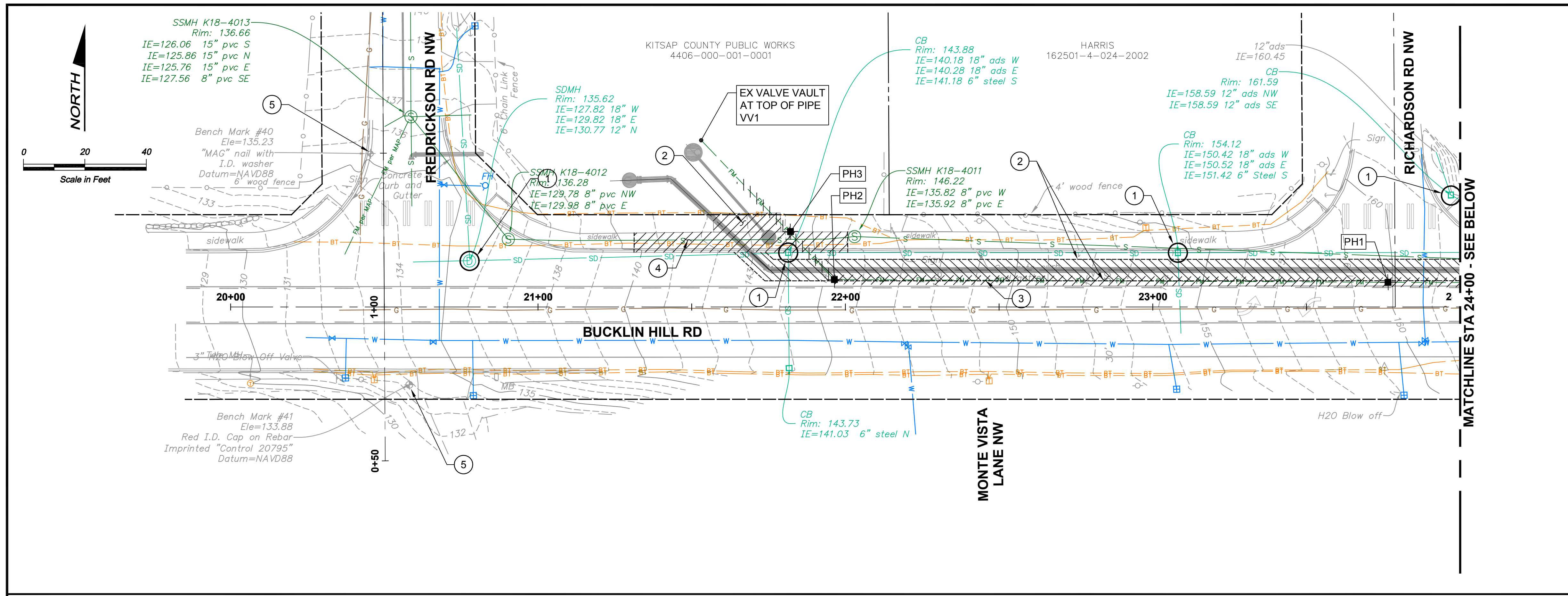

**NOTES:**

- FOR ALL SURFACES SUBJECT TO VEHICULAR TRAFFIC, RESTORE DISTURBED AREA WITH 1" MINIMUM TEMPORARY HMA PATCH AND TEMPORARY STRIPING BY THE END OF EACH WORK DAY. MAINTAIN TEMPORARY HMA PATCH AND TEMPORARY STRIPING UNTIL REPLACED WITH PERMANENT HMA PATCH AND STRIPING.

**CONSTRUCTION NOTES:**

- INSTALL CATCH BASIN INSERT, PER DETAIL 3/C-1.
- SAWCUT AND REMOVE FULL DEPTH OF EXISTING HMA, SEE NOTE 1 ABOVE.
- ABANDON EXISTING 16" SANITARY SEWER FORCE MAIN PER SPECIAL PROVISIONS. EXISTING FORCE MAIN SHALL NOT BE ABANDONED UNTIL THE LIFT STATION 4 BYPASS SYSTEM IS FULLY OPERATIONAL.
- SAWCUT AND REMOVE FULL DEPTH OF CONCRETE SIDEWALK, CURB, AND GUTTER TO THE NEAREST CONSTRUCTION JOINT.
- PROTECT BENCHMARK/SURVEY MONUMENT. IF THE BENCHMARK/MONUMENT MUST BE DISTURBED, WORK SHALL COMPLY WITH SECTION 1-05.4 OF THE SPECIAL PROVISIONS AND THE WASHINGTON STATE DNR PERMIT TO DESTROY OR REMOVE A SURVEY MONUMENT.

POTHOLE DATA		
PH#	EXISTING HMA THICKNESS	DEPTH TO UTILITY
VV1	N/A	4.35' BFG
PH1	12"	6.65' BFG
PH2	10"	6.70' BFG
PH3	N/A	6.85' BFG
PH4	10"	4.85' BFG

**LEGEND:**

BFG BELOW FINISH GRADE TO TOP OF PIPE.

■ POTHOLE

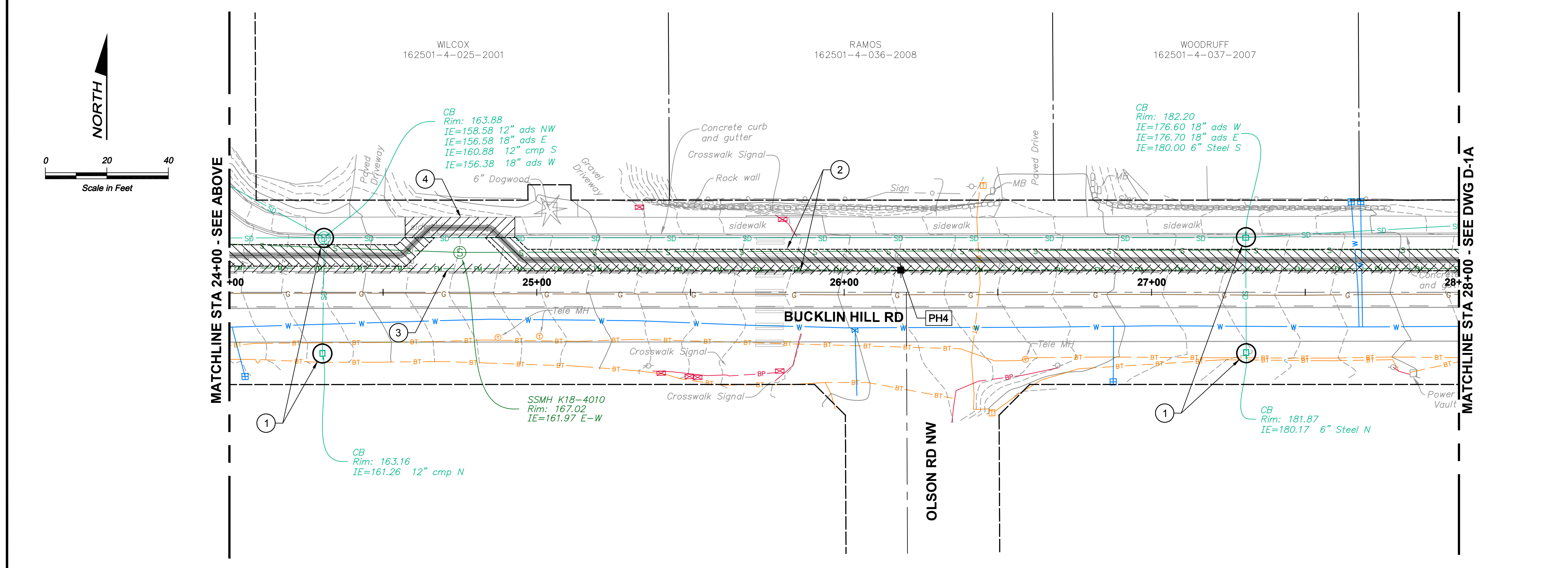

**Call 48 Hours Before You Dig**

**1-800-424-5555**

UNDERGROUND SERVICE

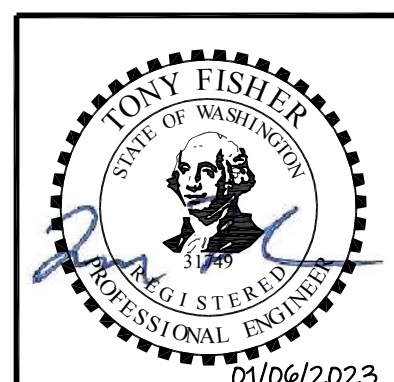

Path: S:\Cad\Kitsap County\21-10530 Silverdale Conveyance-PS 4 Uprgr\Design\Drawings\21-10530-SCU\_Pothole.dwg  
 Plot date: Jan 06, 2023 01:10:37pm  
 CAD User: selsee  
 Xref Filename: I:\Fisher\10530-SCU\_Ext\Topo\10530-SCU\_Prop SS\10530-SCU\_Pothole.dwg | Palmiter |

No.	Revision	Date	By	App'd

**bhc CONSULTANTS**

**BHC Consultants, LLC**  
 1601 Fifth Avenue, Suite 500  
 Seattle, Washington 98101  
 206.505.3400  
 206.505.3406 (fax)  
 www.bhcconsultants.com

Designed: T. Fisher, P.E.  
 Drawn: A. Cariaso  
 Checked: R. Dorn, P.E.

Scale:  
 1" = 20'-0"  
 One Inch at Full Scale  
 If Not One Inch Scale Accordingly

**Kitsap County Public Works**  
 614 Division Street, MS 26  
 Port Orchard, WA 98366

**SILVERDALE CONVEYANCE SYSTEM AND PUMP STATION 4 UPGRADES**  
 SCHEDULE A  
**BUCKLIN HILL RD**  
**DEMOLITION AND TESC PLAN**  
**STA 21+00 TO STA 28+00**

Drawing: **D-1A**  
 Sheet: **15** of **117**  
 File: P21-10530\_D-1A-2A  
 Date: January 2023

Path: S:\Cadd\Kitsap County\21-10530 Silverdale Conveyance-PS 4 Uprgr\Design\Drawings\21-10530-SCU\_Pothole.dwg  
 Xref Filename: I:\Fisher\1\21-10530-SCU\_Prop SS\1\21-10530-SCU\_Pothole.dwg  
 Plot date: Jan 06, 2023 01:56:09pm  
 CAD User: selsee

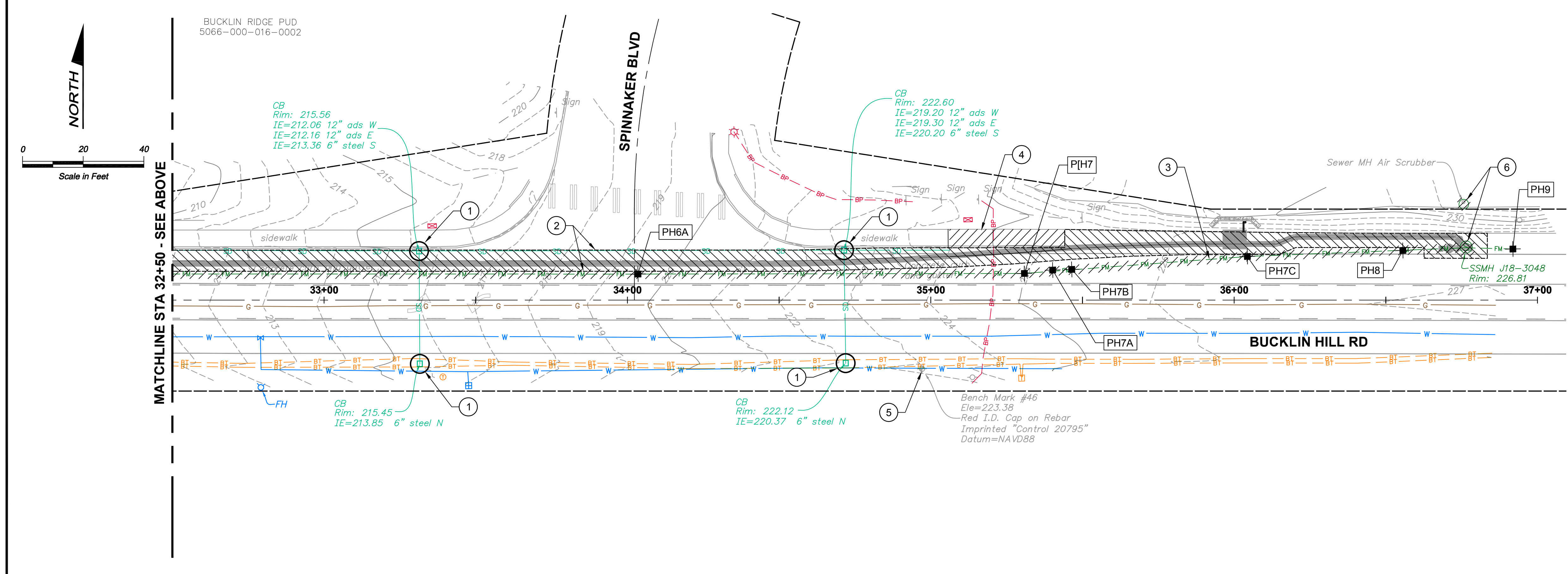
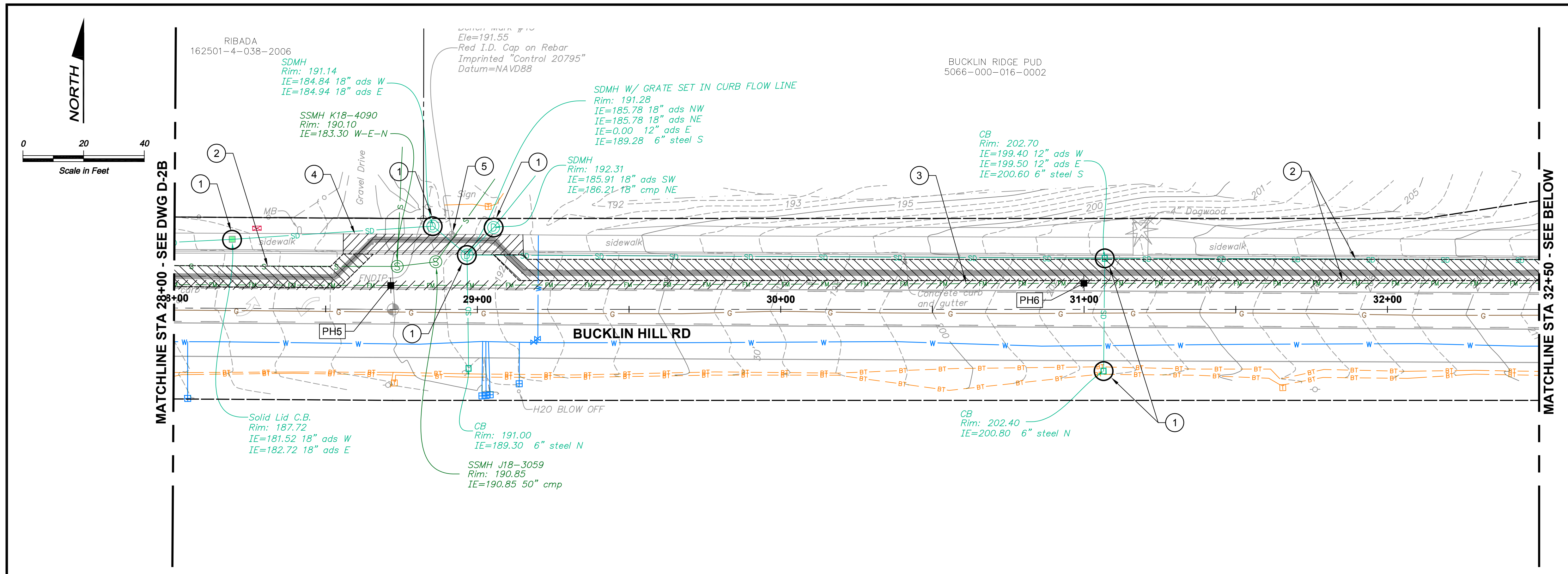

**NOTES:**

- FOR ALL SURFACES SUBJECT TO VEHICULAR TRAFFIC, RESTORE DISTURBED AREA WITH 1" MINIMUM TEMPORARY HMA PATCH AND TEMPORARY STRIPING BY THE END OF EACH WORK DAY. MAINTAIN TEMPORARY HMA PATCH AND TEMPORARY STRIPING UNTIL REPLACED WITH PERMANENT HMA PATCH AND STRIPING.

**CONSTRUCTION NOTES:**

- INSTALL CATCH BASIN INSERT, PER DETAIL 3/C-1.
- SAWCUT AND REMOVE FULL DEPTH OF EXISTING HMA, SEE NOTE 1 ABOVE.
- ABANDON EXISTING 16" SANITARY SEWER FORCE MAIN PER SPECIAL PROVISIONS. EXISTING FORCE MAIN SHALL NOT BE ABANDONED UNTIL THE LIFT STATION 4 BYPASS SYSTEM IS FULLY OPERATIONAL.
- SAWCUT AND REMOVE FULL DEPTH OF CONCRETE SIDEWALK, CURB, AND GUTTER TO THE NEAREST CONSTRUCTION JOINT.
- PROTECT BENCHMARK/SURVEY MONUMENT. IF THE BENCHMARK/MONUMENT MUST BE DISTURBED, WORK SHALL COMPLY WITH SECTION 1-05.4 OF THE SPECIAL PROVISIONS AND THE WASHINGTON STATE DNR PERMIT TO DESTROY OR REMOVE A SURVEY MONUMENT.
- REMOVE AND PROPERLY DISPOSE OF EXISTING AIR SCRUBBER AND MANHOLE.

POTHOLE DATA		
PH#	EXISTING HMA THICKNESS	DEPTH TO UTILITY
PH5	12"	5.20' BFG
PH6	12"	4.70' BFG
PH6A	9"	4.75' BFG
PH7	10"	6.42' BFG
PH7A	10"	6.70' BFG
PH7B	10"	6.90' BFG
PH7C*	14"	4.70' BFG
PH8	9"	7.60' BFG
PH9	8"	6.90' BFG

\* ENCOUNTERED TWO 2" HDPE PIPES ABOVE EX SSMF (4.5' BFG)

**LEGEND:**

- BFG BELOW FINISH GRADE TO TOP OF PIPE.
- POTHOLE

**Call 48 Hours Before You Dig**  
 1-800-424-5555  
 UNDERGROUND SERVICE

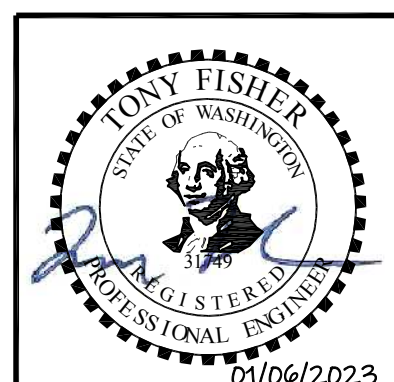

No.	Revision	Date	By	App'd
	ISSUED FOR BID	01-2023	TF	RAD

**bhc CONSULTANTS**  
 BHC Consultants, LLC  
 1601 Fifth Avenue, Suite 500  
 Seattle, Washington 98101  
 206.505.3400  
 206.505.3406 (fax)  
 www.bhcconsultants.com

Designed: T. Fisher, P.E.  
 Drawn: A. Cariaso  
 Checked: R. Dorn, P.E.

Scale:  
 1" = 20'-0"  
 One Inch at Full Scale  
 If Not One Inch Scale Accordingly



**Kitsap County Public Works**  
 614 Division Street, MS 26  
 Port Orchard, WA 98366

**SILVERDALE CONVEYANCE SYSTEM AND PUMP STATION 4 UPGRADES SCHEDULE A**  
**BUCKLIN HILL RD**  
**DEMOLITION AND TESC PLAN**  
**STA 28+00 TO STA 37+00**

Drawing: **D-2A**  
 Sheet: **16** of **117**  
 File: P21-10530\_D-1A-2A  
 Date: January 2023



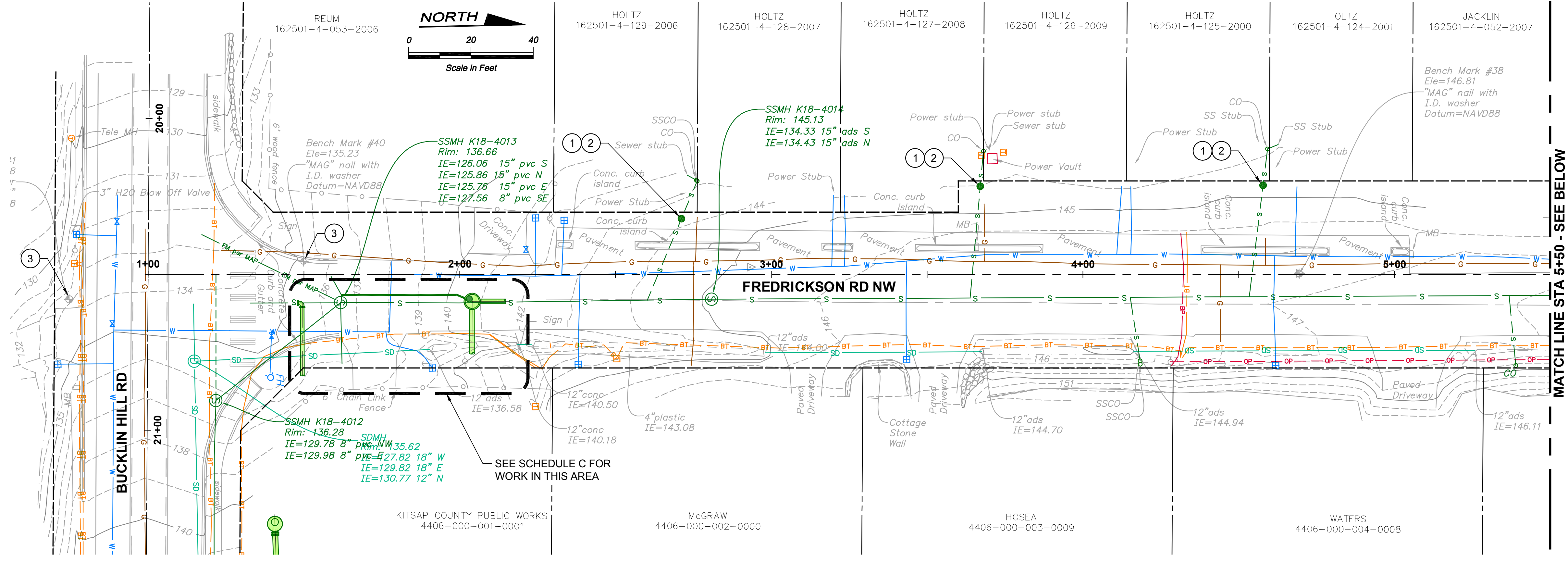

- NOTES:**
- FOR ALL SURFACES SUBJECT TO VEHICULAR TRAFFIC, RESTORE DISTURBED AREA WITH 1" MINIMUM TEMPORARY HMA PATCH AND TEMPORARY STRIPING BY THE END OF EACH WORK DAY. MAINTAIN TEMPORARY HMA PATCH AND TEMPORARY STRIPING UNTIL REPLACED WITH PERMANENT HMA PATCH AND STRIPING.
  - BYPASS FLOWS AND COORDINATE WITH PROPERTY OWNERS AS NECESSARY TO FACILITATE CONNECTIONS TO THE EXISTING SIDE SEWER.

- CONSTRUCTION NOTES:**
- INSTALL FILTER FABRIC FENCE PER DETAIL 1/C-1 DOWNSTREAM OF ALL SOIL DISTURBING ACTIVITIES PRIOR TO DISTURBING ANY GROUND.
  - INSTALL CLEANOUT PER DETAIL 6/C-2. RESTORE DISTURBED AREA TO PRE-EXISTING CONDITION OR BETTER.
  - PROTECT BENCHMARK/SURVEY MONUMENT. IF THE BENCHMARK/ MONUMENT MUST BE DISTURBED, WORK SHALL COMPLY WITH SECTION 1-05.4 OF THE SPECIAL PROVISIONS AND THE WASHINGTON STATE DNR PERMIT TO DESTROY OR REMOVE A SURVEY MONUMENT.

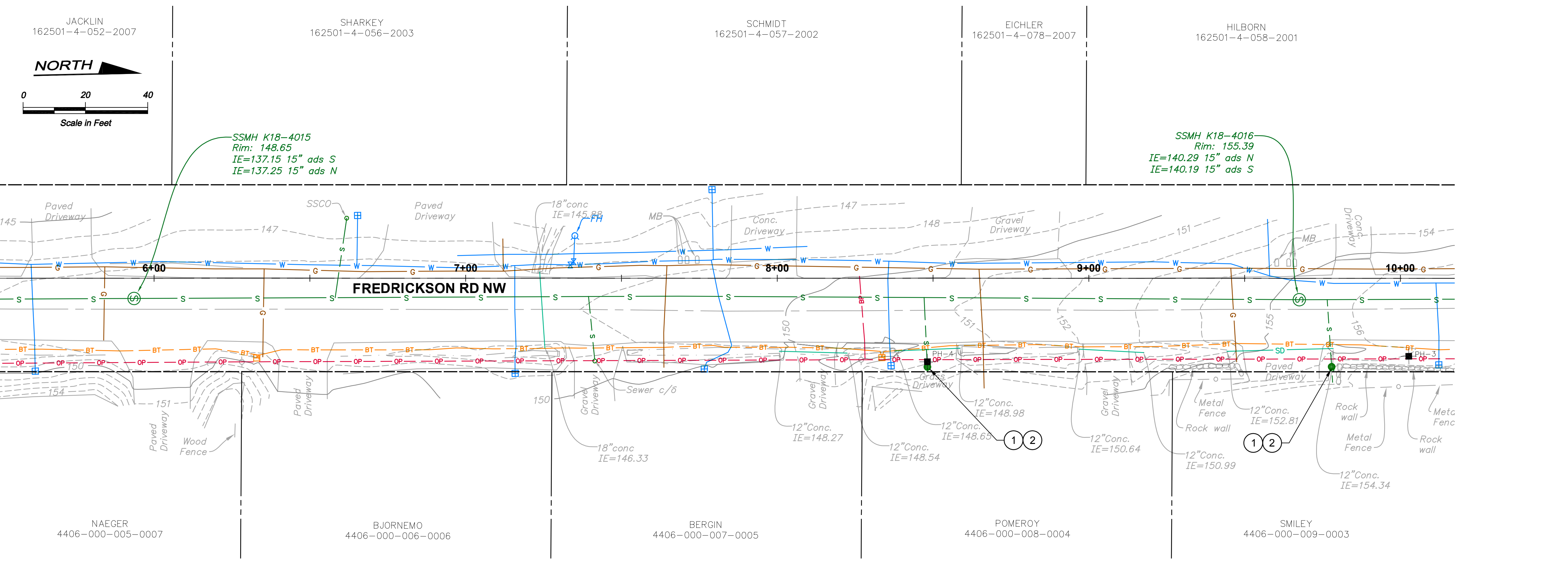

**Call 48 Hours Before You Dig**  
1-800-424-5555  
UNDERGROUND SERVICE

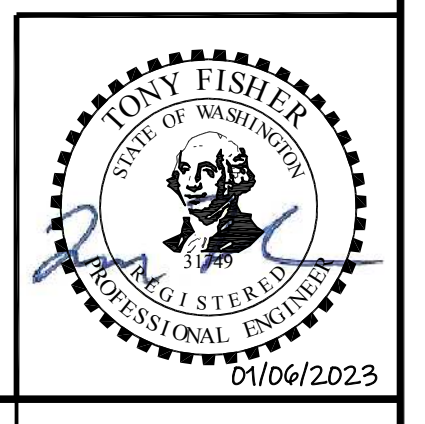

Path: S:\CAD\Kitsap County\21-10530 Silverdale Conveyance-PS-4 UprgrDesign.dwg, Filename: P21-10530\_C-1A, Pld date: Jan 06, 2023, 01:16:08pm, CAD User: JLF, Xref Filename: I Fisher\1\21-10530-SCU\_Ext\Topo\1\21-10530-SCU\_Prop\_Site\1\21-10530-SCU\_Prop\_SS\1\Palmer1

No.	Revision	Date	By	App'd
	ISSUED FOR BID	01-2023	TF	RAD



**BHC Consultants, LLC**  
1601 Fifth Avenue, Suite 500  
Seattle, Washington 98101  
206.505.3400  
206.505.3406 (fax)  
www.bhcconsultants.com

Designed: T. Fisher, P.E.  
Drawn: P. Simon  
Checked: R. Dorn, P.E.

Scale:  
1" = 20'-0"  
One Inch at Full Scale  
If Not One Inch Scale Accordingly



**Kitsap County Public Works**  
614 Division Street, MS 26  
Port Orchard, WA 98366

**SILVERDALE CONVEYANCE SYSTEM AND PUMP STATION 4 UPGRADES**  
SCHEDULE A  
**FREDRICKSON RD NW**  
PLANS  
**STA 1+00 TO STA 10+00**

Drawing: **C-1A**  
Sheet: **17** of **117**  
File: P21-10530\_C-1A  
Date: January 2023

Path: S:\CAD\Kitsap County\21-10530 Silverdale Conveyance-PS 4 Uprgt\Design\Drawings\21-10530\_C-2A-5A\_Plot.dwg, Jan 06, 2023 02:28:07pm, CAD User: J.Lira, Xref File Name: \X21-10530-EG\_Sch AB\X21-10530-SCU\_Prop SS\X21-10530-SCU\_Ex Align\Prof\X21-10530-SCU\_Pothole\X21-10530-SCU\_Ex Topo\X21-10530-TB\Fisher\Dat\Palmer\

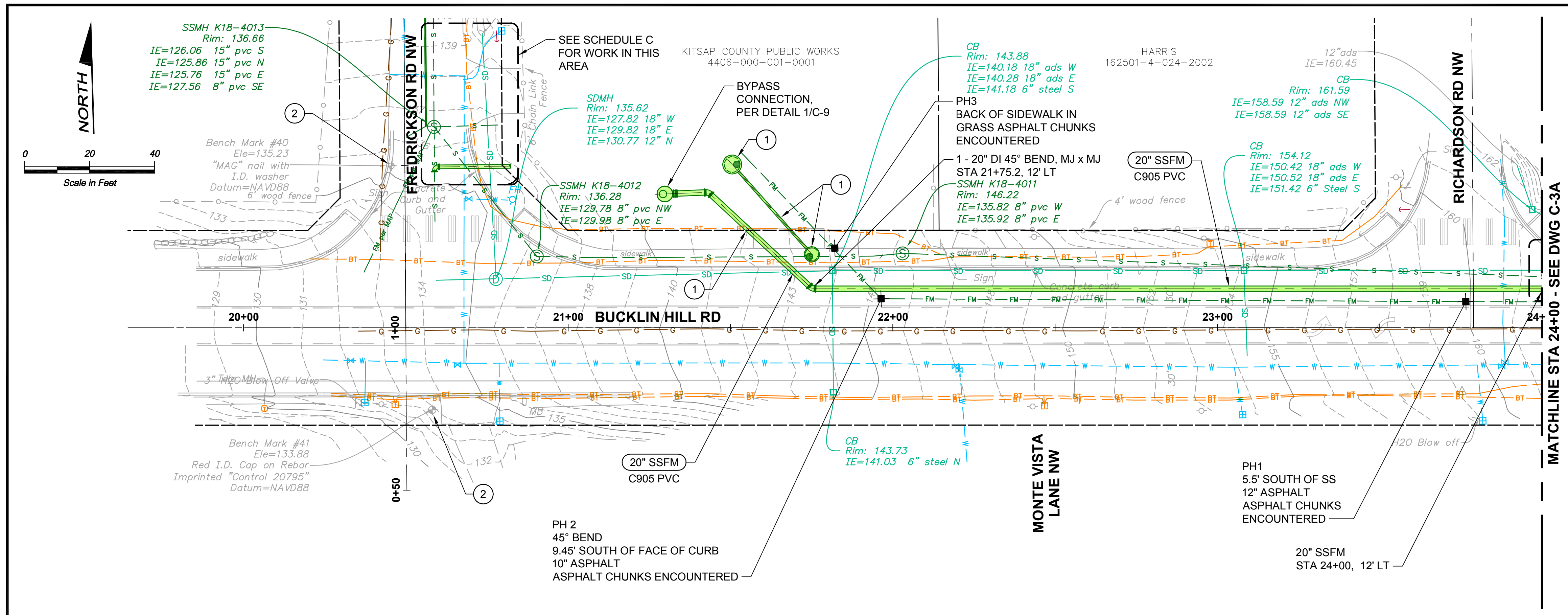

MATCHLINE STA 24+00 - SEE DWG C-3A

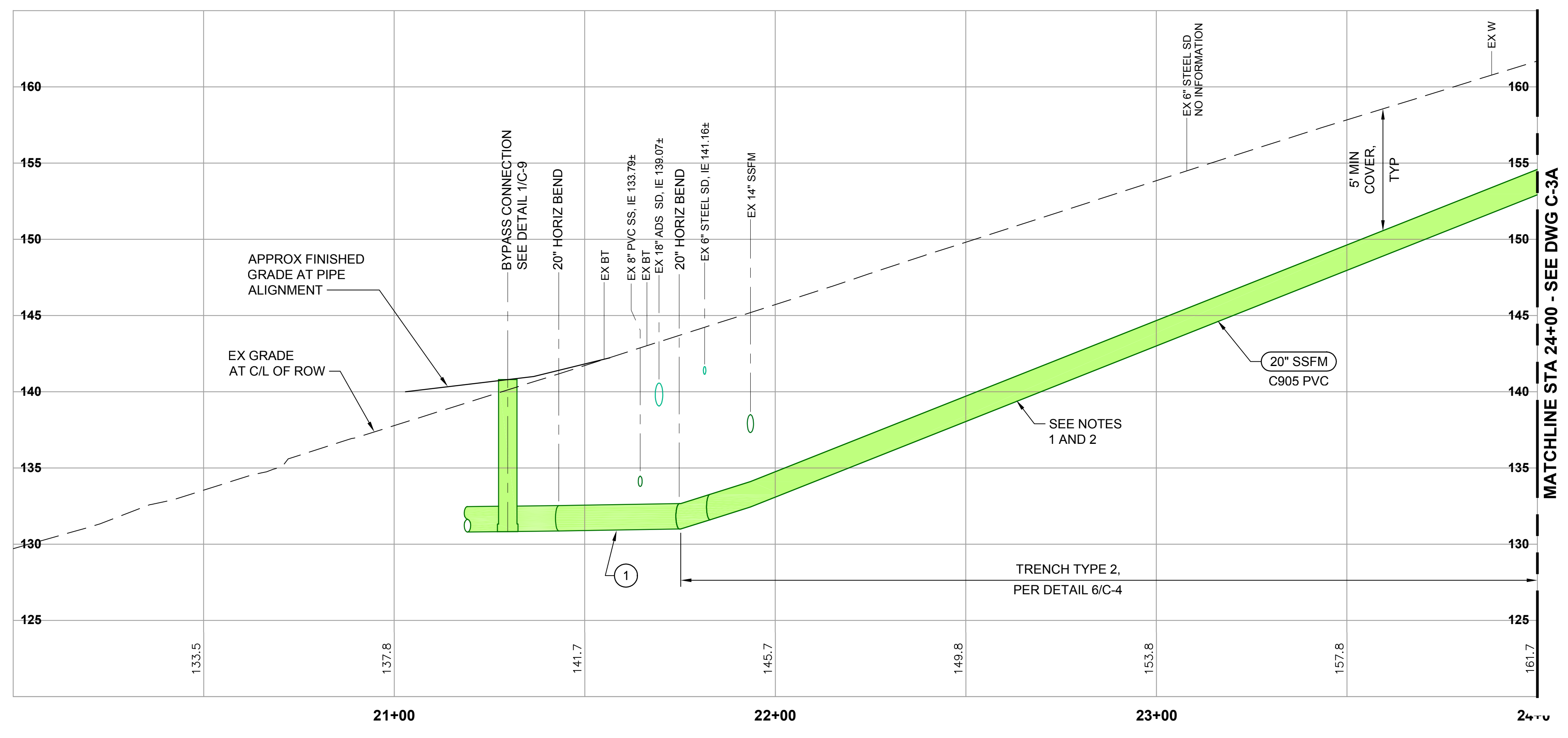

MATCHLINE STA 24+00 - SEE DWG C-3A

**NOTES:**

- 1. MAINTAIN POSITIVE SLOPE ON THE FORCE MAIN AND AVOID HIGH AND LOW POINTS UNLESS SPECIFICALLY CALLED OUT.
- 2. DEFLECT PIPE VERTICALLY PER MANUFACTURER'S RECOMMENDATIONS TO SMOOTHLY TRANSITION GRADE WHILE ADHERING TO COVER REQUIREMENTS.
- 3. FOR ALL SURFACES SUBJECT TO VEHICULAR TRAFFIC, RESTORE DISTURBED AREAS WITH 1" MIN TEMPORARY HMA PATCH AND TEMP STRIPING BY THE END OF EACH WORK DAY. MAINTAIN TEMP HMA PATCH AND TEMP STRIPING UNTIL IT IS REPLACED WITH THE PERMANENT RESTORATION.
- 4. POT HOLE EXISTING UTILITIES AS NECESSARY TO VERIFY INVERTS PRIOR TO CONSTRUCTING FORCE MAIN TO ALLOW ADJUSTMENTS TO FORCE MAIN DEPTH TO MAINTAIN AT LEAST 12 INCHES OF VERTICAL SEPARATION.
- 5. ALL MJ FITTINGS SHALL BE RESTRAINED AND HAVE A THRUST BLOCKS UNLESS NOTED OTHERWISE.

**CONSTRUCTION NOTES:**

- ① SEE SCHEDULE C FOR THIS WORK.
- ② PROTECT BENCHMARK/MONUMENT. IF THE BENCHMARK/MONUMENT MUST BE DISTURBED, WORK SHALL COMPLY WITH SECTION 1-05.4 OF THE SPECIAL PROVISIONS AND THE WASHINGTON STATE DNR PERMIT TO DESTROY OR REMOVE A SURVEY MONUMENT.

**POTHOLE NOTES:**

- 1. SEE DWG D-1A FOR ASPHALT THICKNESS AND DEPTH TO UTILITY.
- 2. NO GROUND WATER WAS ENCOUNTERED AT ANY POT HOLE LOCATIONS.
- 3. SOILS AT POT HOLE LOCATIONS APPEARED TO BE A PIT RUN OR GRAVEL BORROW LIKE MATERIAL WITH SILTY SAND.

**Call 48 Hours Before You Dig**  
**1-800-424-5555**  
UNDERGROUND SERVICE

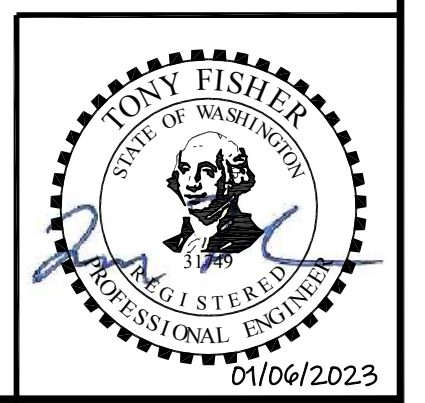

**BHC Consultants, LLC**  
1601 Fifth Avenue, Suite 500  
Seattle, Washington 98101  
206.505.3400  
206.505.3406 (fax)  
www.bhcconsultants.com

Designed: T. Fisher, P.E.  
Drawn: P. Simon  
Checked: R. Dorn, P.E.

Scale:  
Horiz: 1" = 20'-0"  
Vert: 1" = 5'-0"  
One Inch at Full Scale  
If Not One Inch Scale Accordingly



**Kitsap County Public Works**  
614 Division Street, MS 26  
Port Orchard, WA 98366

**SILVERDALE CONVEYANCE SYSTEM AND PUMP STATION 4 UPGRADES  
SCHEDULE A  
BUCKLIN HILL RD  
PLAN AND PROFILE  
STA 21+00 TO STA 24+00**

Drawing:	<b>C-2A</b>
Sheet:	18 of 117
File:	P21-10530_C-2A-5A
Date:	January 2023

No.	Revision	Date	By	App'd
ISSUED FOR BID		01-2023	TF	RAD

Path: S:\Cadd\Kitsap County\21-10530 Silverdale Conveyance\PS 4 Upgr\Design\Drawings\C-2A-5A Plot date: Mar 20, 2023 02:31:31pm CAD User: soisoe  
 Xref Filename: | X21-10530-EG Sch A-B | X21-10530-SCU\_Exp SS | X21-10530-SCU\_Exp Topo | X21-10530-SCU\_Pothole | X21-10530-SCU\_Ex Topo | X21-10530\_TB | Fisher | Dahl | Palmatier |

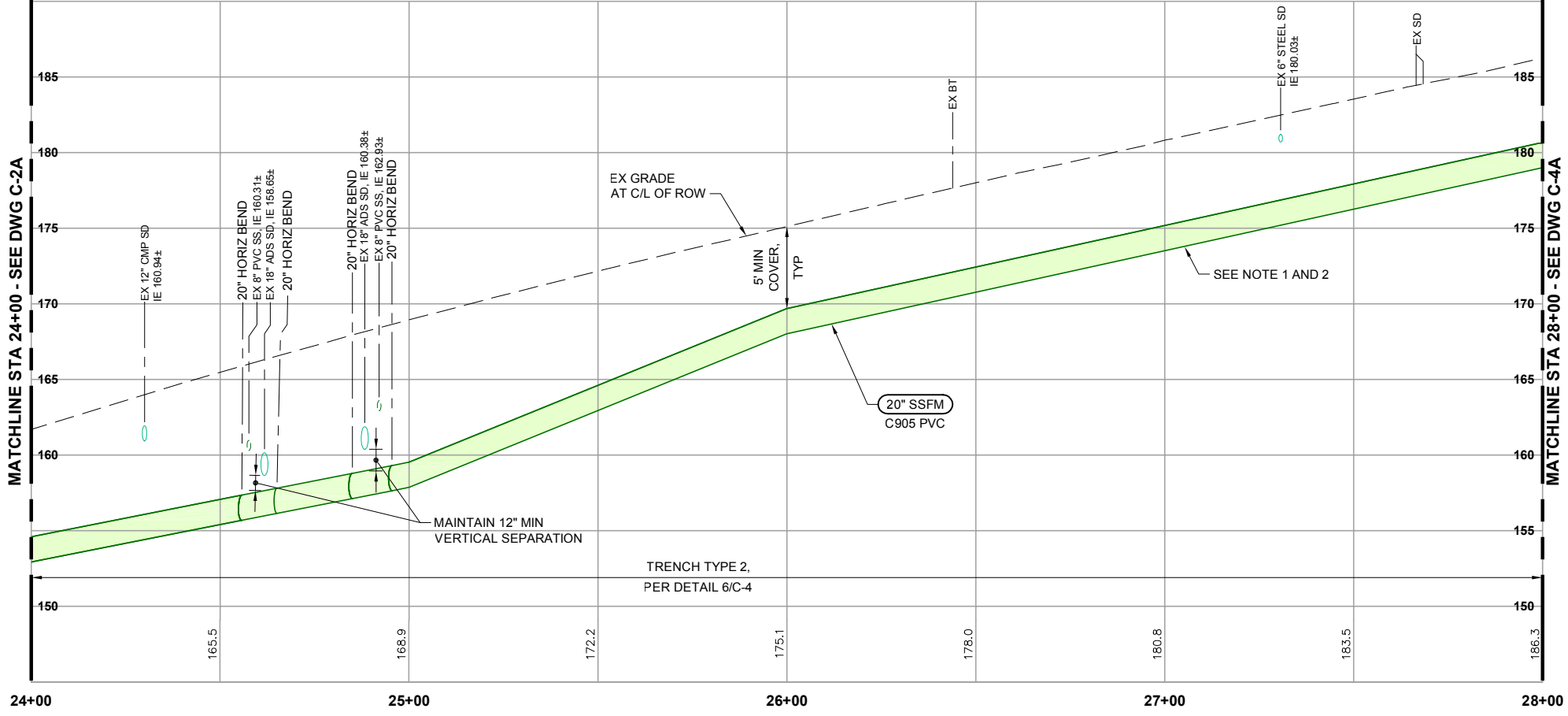
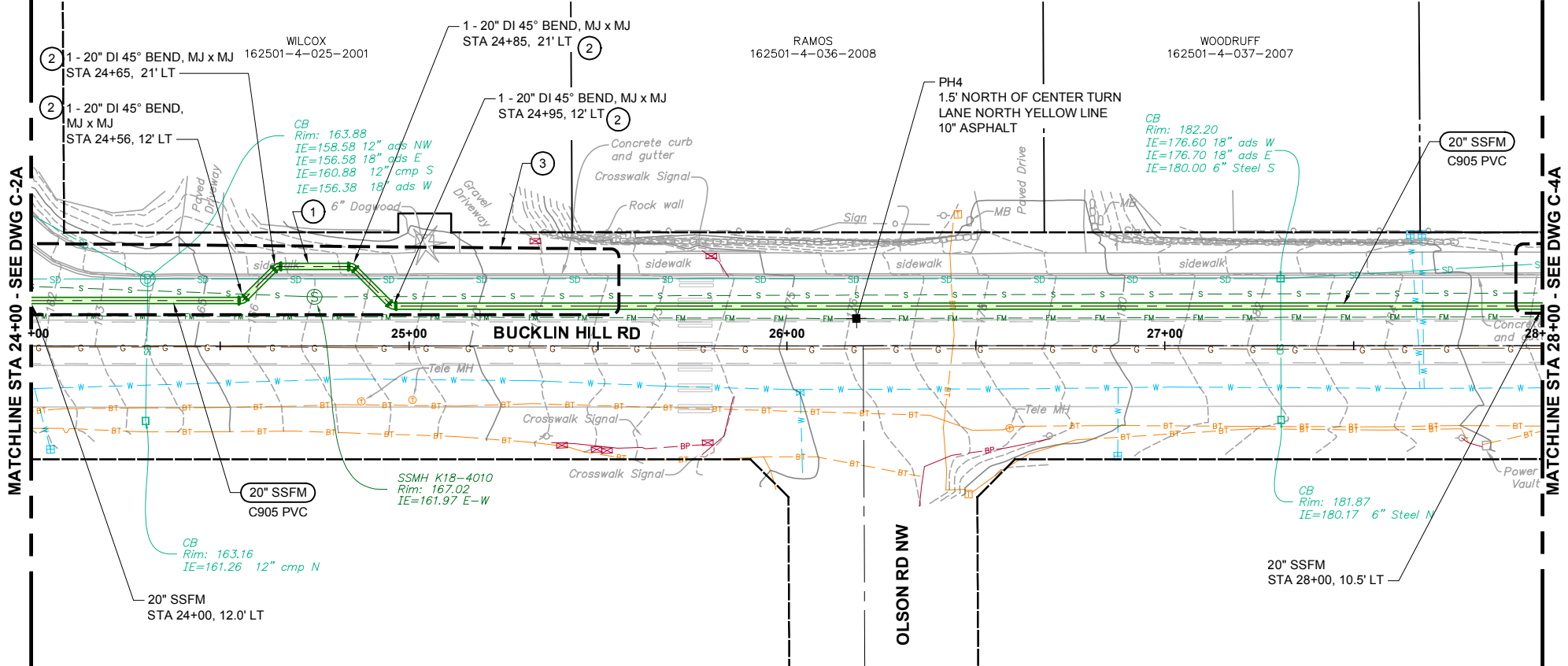
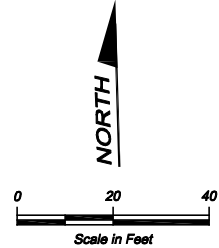

- NOTES:**
1. MAINTAIN POSITIVE SLOPE ON THE FORCE MAIN AND AVOID HIGH AND LOW POINTS UNLESS SPECIFICALLY CALLED OUT.
  2. DEFLECT PIPE VERTICALLY PER MANUFACTURER'S RECOMMENDATIONS TO SMOOTHLY TRANSITION GRADE WHILE ADHERING TO COVER REQUIREMENTS.
  3. FOR ALL SURFACES SUBJECT TO VEHICULAR TRAFFIC, RESTORE DISTURBED AREAS WITH 1" MIN TEMPORARY HMA PATCH AND TEMP STRIPING BY THE END OF EACH WORK DAY. MAINTAIN TEMP HMA PATCH AND TEMP STRIPING UNTIL IT IS REPLACED WITH THE PERMANENT RESTORATION.
  4. POTHOLE EXISTING UTILITIES AS NECESSARY TO VERIFY INVERTS PRIOR TO CONSTRUCTING FORCE MAIN TO ALLOW ADJUSTMENTS TO FORCE MAIN DEPTH TO MAINTAIN AT LEAST 12 INCHES OF VERTICAL SEPARATION.
  5. ALL MJ FITTINGS SHALL BE RESTRAINED AND HAVE THRUST BLOCKS UNLESS NOTED OTHERWISE.

- CONSTRUCTION NOTES:**
- 1 MAINTAIN 2 FOOT CLEARANCE FROM SSMH.
  - 2 ROTATE BEND AS NEEDED TO ACHIEVE GRADES TO CLEAR EXISTING UTILITIES.
  - 3 RESTRAIN ALL JOINTS WITHIN 60 FEET OF BENDS IN LIEU OF THRUST BLOCKS. PIPE JOINTS MORE THAN 60 FEET FROM THE BEND MAY BE RESTRAINED OR UNRESTRAINED AT CONTRACTOR'S OPTION UNLESS NOTED OTHERWISE.

- POTHOLE NOTES:**
1. SEE DWG D-1A FOR ASPHALT THICKNESS AND DEPTH TO UTILITY. EXISTING ASPHALT THICKNESS RANGED BETWEEN 8-INCHES AND 14-INCHES.
  2. NO GROUND WATER WAS ENCOUNTERED AT ANY POTHOLE LOCATIONS.
  3. SOILS AT POTHOLE LOCATIONS APPEARED TO BE A PIT RUN OR GRAVEL BORROW LIKE MATERIAL WITH SILTY SAND.

**Call 48 Hours Before You Dig**  
 1-800-424-5555  
 UNDERGROUND SERVICE

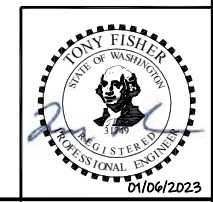

No.	Revision	Date	By	App'd
	ISSUED FOR BID	01-2023	TF	RAD



**BHC Consultants, LLC**  
 1601 Fifth Avenue, Suite 500  
 Seattle, Washington 98101  
 206.505.3400  
 206.505.3406 (fax)  
 www.bhcconsultants.com

Designed: T. Fisher, P.E.  
 Drawn: P. Simon  
 Checked: R. Dorn, P.E.

Scale:  
 Horiz: 1" = 20'-0"  
 Vert: 1" = 5'-0"  
 One Inch at Full Scale  
 If Not One Inch Scale Accordingly



**Kitsap County Public Works**  
 614 Division Street, MS 26  
 Port Orchard, WA 98366

**SILVERDALE CONVEYANCE SYSTEM AND PUMP STATION 4 UPGRADES**  
 SCHEDULE A  
**BUCKLIN HILL RD**  
**PLAN AND PROFILE**  
**STA 24+00 TO STA 28+00**

Drawing: **C-3A**  
 Sheet: **19** of **117**  
 File: P21-10530\_C-2A-5A  
 Date: January 2023

Path: S:\Cadd\Kitsap County\21-10530 Silverdale Conveyance-PS 4 Uprgr\Design\Drawings\21-10530\_C-2A-5A\_Plan.dwg Plot date: Jan 06, 2023 02:44:36pm CAD User: J.Lira  
 Xref Filename: 21-10530-EG Sch AB | 21-10530-SCU\_Ex Align-Prop SS | 21-10530-SCU\_Ex Align-Prop SS | 21-10530-SCU\_Pothole | 21-10530-SCU\_Ex Topo | 21-10530\_TB | Fisher | Dan | Palmalter |

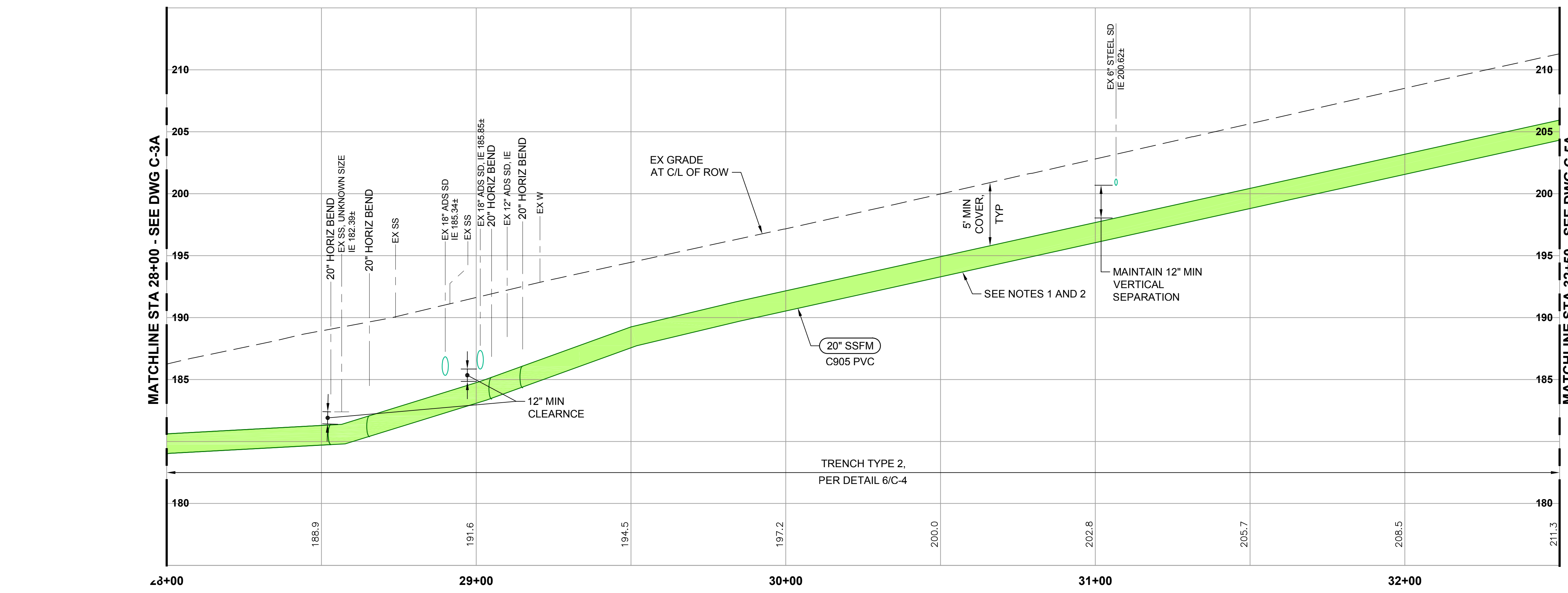
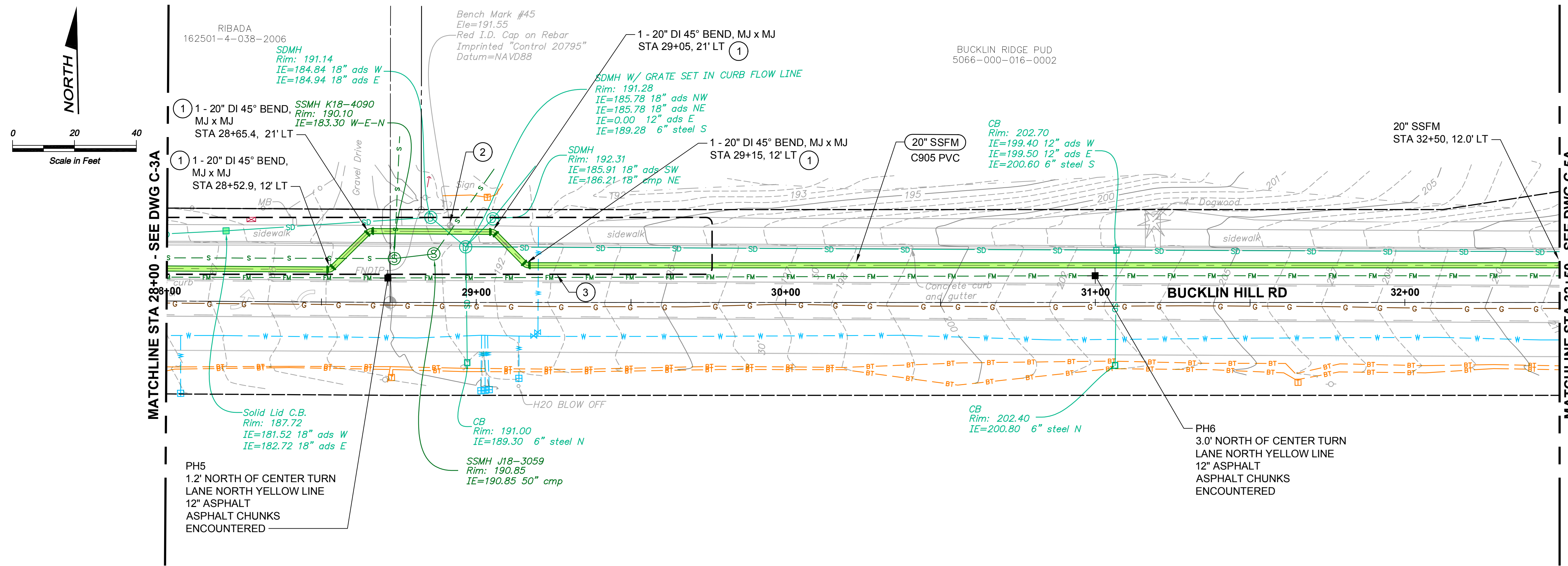

- NOTES:**
1. MAINTAIN POSITIVE SLOPE ON THE FORCE MAIN AND AVOID HIGH AND LOW POINTS UNLESS SPECIFICALLY CALLED OUT.
  2. DEFLECT PIPE VERTICALLY PER MANUFACTURER'S RECOMMENDATIONS TO SMOOTHLY TRANSITION GRADE WHILE ADHERING TO COVER REQUIREMENTS.
  3. FOR ALL SURFACES SUBJECT TO VEHICULAR TRAFFIC, RESTORE DISTURBED AREAS WITH 1" MIN TEMPORARY HMA PATCH AND TEMP STRIPING BY THE END OF EACH WORK DAY. MAINTAIN TEMP HMA PATCH AND TEMP STRIPING UNTIL IT IS REPLACED WITH THE PERMANENT RESTORATION.
  4. POTHOLE EXISTING UTILITIES AS NECESSARY TO VERIFY INVERTS PRIOR TO CONSTRUCTING FORCE MAIN TO ALLOW ADJUSTMENTS TO FORCE MAIN DEPTH TO MAINTAIN AT LEAST 12 INCHES OF VERTICAL SEPARATION.
  5. ALL MJ FITTINGS SHALL BE RESTRAINED AND HAVE THRUST BLOCKS UNLESS NOTED OTHERWISE.
- CONSTRUCTION NOTES:**
- 1 ROTATE BEND AS NEEDED TO ACHIEVE GRADES TO CLEAR EXISTING UTILITIES.
  - 2 PROTECT BENCHMARK/SURVEY MONUMENT. IF THE BENCHMARK/ MONUMENT MUST BE DISTURBED, WORK SHALL COMPLY WITH SECTION 1-05.4 OF THE SPECIAL PROVISIONS AND THE WASHINGTON STATE DNR PERMIT TO DESTROY OR REMOVE A SURVEY MONUMENT.
  - 3 RESTRAIN ALL JOINTS WITHIN 60 FEET OF BENDS IN LIEU OF THRUST BLOCKS.

- POTHOLE NOTES:**
1. SEE DWG D-2A FOR ASPHALT THICKNESS AND DEPTH TO UTILITY. EXISTING ASPHALT THICKNESS RANGED BETWEEN 8-INCHES AND 14-INCHES.
  2. NO GROUND WATER WAS ENCOUNTERED AT ANY POTHOLE LOCATIONS.
  3. SOILS AT POTHOLE LOCATIONS APPEARED TO BE A PIT RUN OR GRAVEL BORROW LIKE MATERIAL WITH SILTY SAND.

**Call 48 Hours Before You Dig**  
 1-800-424-5555  
 UNDERGROUND SERVICE

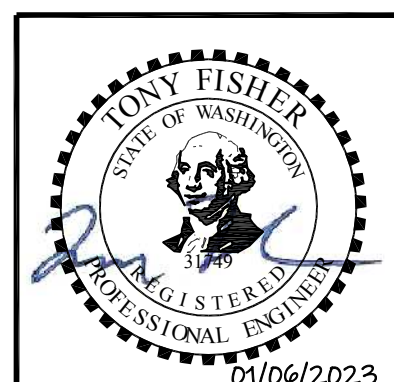

No.	Revision	Date	By	App'd
	ISSUED FOR BID	01-2023	TF	RAD

**bhc CONSULTANTS**  
 BHC Consultants, LLC  
 1601 Fifth Avenue, Suite 500  
 Seattle, Washington 98101  
 206.505.3400  
 206.505.3406 (fax)  
 www.bhcconsultants.com

Designed: T. Fisher, P.E.  
 Drawn: P. Simon  
 Checked: R. Dorn, P.E.

Scale:  
 Horiz: 1" = 20'-0"  
 Vert: 1" = 5'-0"  
 One Inch at Full Scale  
 If Not One Inch Scale Accordingly

**Kitsap County Public Works**  
 614 Division Street, MS 26  
 Port Orchard, WA 98366

**SILVERDALE CONVEYANCE SYSTEM AND PUMP STATION 4 UPGRADES SCHEDULE A**  
**BUCKLIN HILL RD**  
**PLAN AND PROFILE**  
**STA 28+00 TO STA 32+50**

Drawing: **C-4A**  
 Sheet: **20** of **117**  
 File: P21-10530\_C-2A-5A  
 Date: January 2023

Path: S:\Cadd\Kitsap County\21-10530 Silverdale Conveyance-PS 4 Uprgr\Design\Drawings\21-10530\_C-2A-5A\_Plan.dwg Plot date: Jan 06, 2023 02:52:49pm CAD User: J.Lira  
 Xref Filename: \X21-10530-EG Sch AB \X21-10530-SCU\_Ex Align-Profl \X21-10530-SCU\_Pothole \X21-10530-SCU\_Pothole \X21-10530-SCU\_Topog \X21-10530-SCU\_Topog

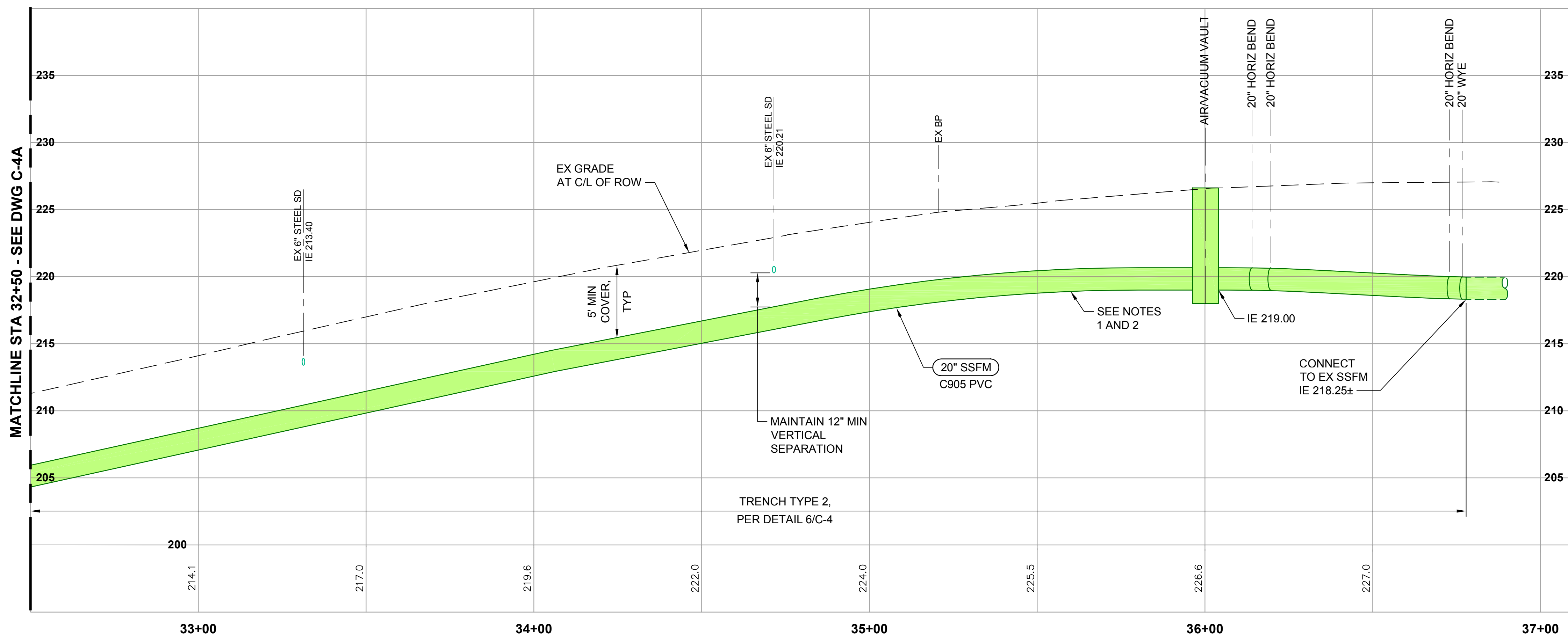
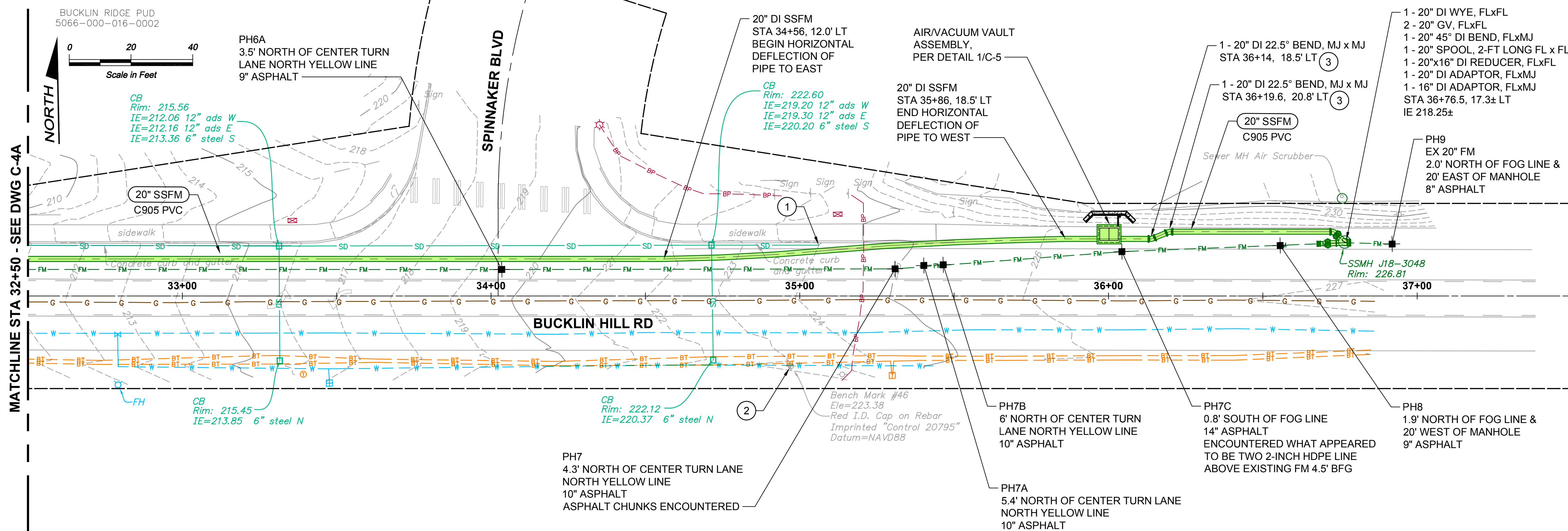

**NOTES:**

1. MAINTAIN POSITIVE SLOPE ON THE FORCE MAIN AND AVOID HIGH AND LOW POINTS UNLESS SPECIFICALLY CALLED OUT.
2. DEFLECT PIPE VERTICALLY PER MANUFACTURER'S RECOMMENDATIONS TO SMOOTHLY TRANSITION GRADE WHILE ADHERING TO COVER REQUIREMENTS.
3. FOR ALL SURFACES SUBJECT TO VEHICULAR TRAFFIC, RESTORE DISTURBED AREAS WITH 1" MIN TEMPORARY HMA PATCH AND TEMP STRIPING BY THE END OF EACH WORK DAY. MAINTAIN TEMP HMA PATCH AND TEMP STRIPING UNTIL IT IS REPLACED WITH THE PERMANENT RESTORATION.
4. POT HOLE EXISTING UTILITIES AS NECESSARY TO VERIFY INVERTS PRIOR TO CONSTRUCTING FORCE MAIN TO ALLOW ADJUSTMENTS TO FORCE MAIN DEPTH TO MAINTAIN AT LEAST 12 INCHES OF VERTICAL SEPARATION.
5. ALL MJ FITTINGS SHALL BE RESTRAINED AND HAVE THRUST BLOCKS UNLESS NOTES OTHERWISE.

**CONSTRUCTION NOTES:**

- 1 END OF EXISTING SD NOT LOCATED. POT HOLE AT CROSSING PRIOR TO CONSTRUCTING SSFM.
- 2 PROTECT BENCHMARK/SURVEY MONUMENT. IF THE BENCHMARK/ MONUMENT MUST BE DISTURBED, WORK SHALL COMPLY WITH SECTION 1-05.4 OF THE SPECIAL PROVISIONS AND THE WASHINGTON STATE DNR PERMIT TO DESTROY OR REMOVE A SURVEY MONUMENT.
- 3 RESTRAIN ALL JOINTS WITHIN 60 FEET OF BENDS IN LIEU OF THRUST BLOCKS.

**POT HOLE NOTES:**

1. SEE DWG D-2A FOR ASPHALT THICKNESS AND DEPTH TO UTILITY. EXISTING ASPHALT THICKNESS RANGED BETWEEN 8-INCHES AND 14-INCHES.
2. NO GROUND WATER WAS ENCOUNTERED AT ANY POT HOLE LOCATIONS.
3. SOILS AT POT HOLE LOCATIONS APPEARED TO BE A PIT RUN OR GRAVEL BORROW LIKE MATERIAL WITH SILTY SAND.

**Call 48 Hours Before You Dig**  
 1-800-424-5555  
 UNDERGROUND SERVICE

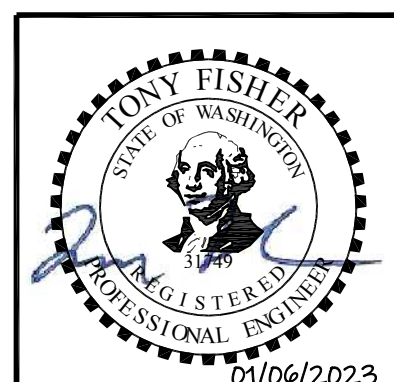

No.	Revision	Date	By	App'd
	ISSUED FOR BID	01-2023	TF	RAD

**bhc CONSULTANTS**  
 BHC Consultants, LLC  
 1601 Fifth Avenue, Suite 500  
 Seattle, Washington 98101  
 206.505.3400  
 206.505.3406 (fax)  
 www.bhcconsultants.com

Designed: T. Fisher, P.E.  
 Drawn: P. Simon  
 Checked: R. Dorn, P.E.

Scale:  
 Horiz: 1" = 20'-0"  
 Vert: 1" = 5'-0"  
 One Inch at Full Scale  
 If Not One Inch Scale Accordingly



**Kitsap County Public Works**  
 614 Division Street, MS 26  
 Port Orchard, WA 98366

**SILVERDALE CONVEYANCE SYSTEM AND PUMP STATION 4 UPGRADES SCHEDULE A**  
**BUCKLIN HILL RD**  
**PLAN AND PROFILE**  
**STA 32+50 TO STA 37+00**

Drawing: **C-5A**  
 Sheet: **21** of **117**  
 File: P21-10530\_C-2A-5A  
 Date: January 2023

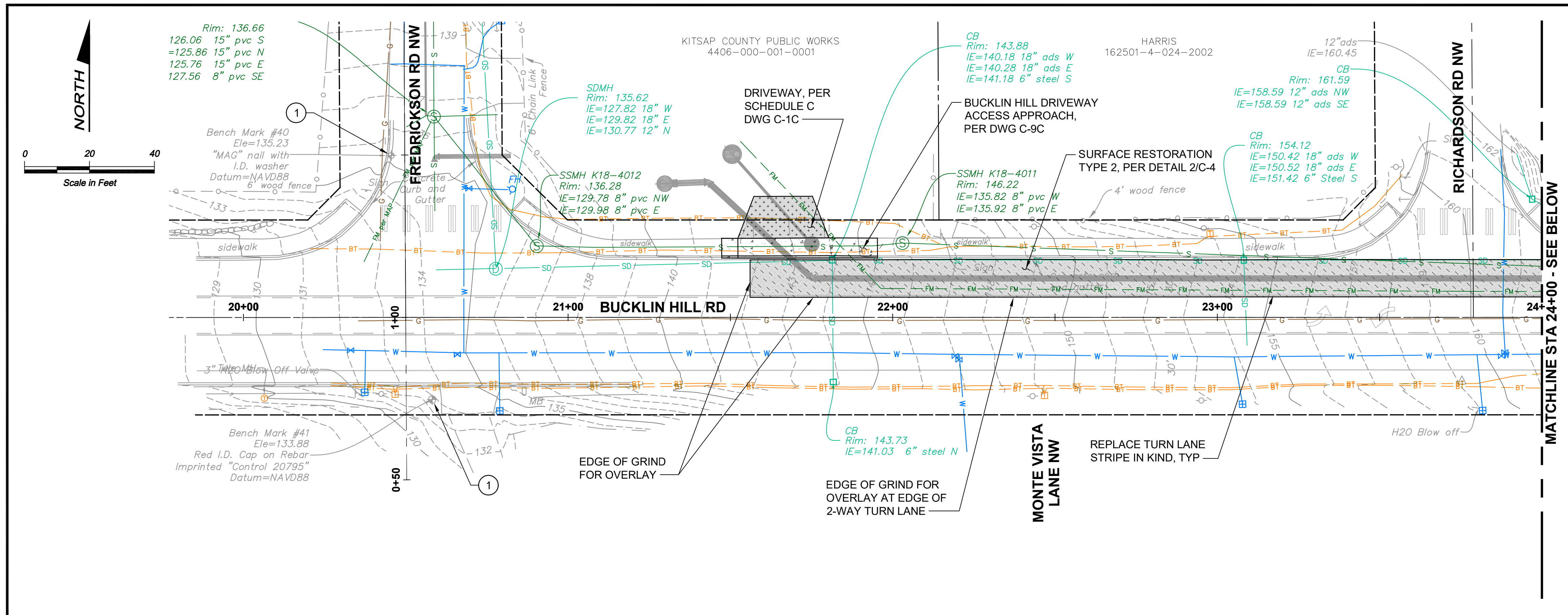

- NOTES:**
- OVERLAY SHALL OCCUPY THE ENTIRE WIDTH OF THE WESTBOUND LANE.
  - REFERENCE STREET CENTERLINE STRIPING, STOP BARS, CROSS WALK STRIPING, AND OTHER SURFACE STREET MARKING PRIOR TO DISTURBING EXISTING AC PAVEMENT. RESTORE ALL MARKINGS IN KIND TO ORIGINAL LOCATIONS AFTER COMPLETION OF FINAL RESTORATION.

- CONSTRUCTION NOTES:**
- PROTECT BENCHMARK/SURVEY MONUMENT. IF THE BENCHMARK/MONUMENT MUST BE DISTURBED, WORK SHALL COMPLY WITH SECTION 1-05.4 OF THE SPECIAL PROVISIONS AND THE WASHINGTON STATE DNR PERMIT TO DESTROY OR REMOVE A SURVEY MONUMENT.

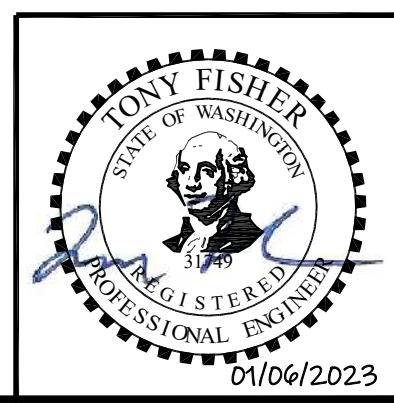
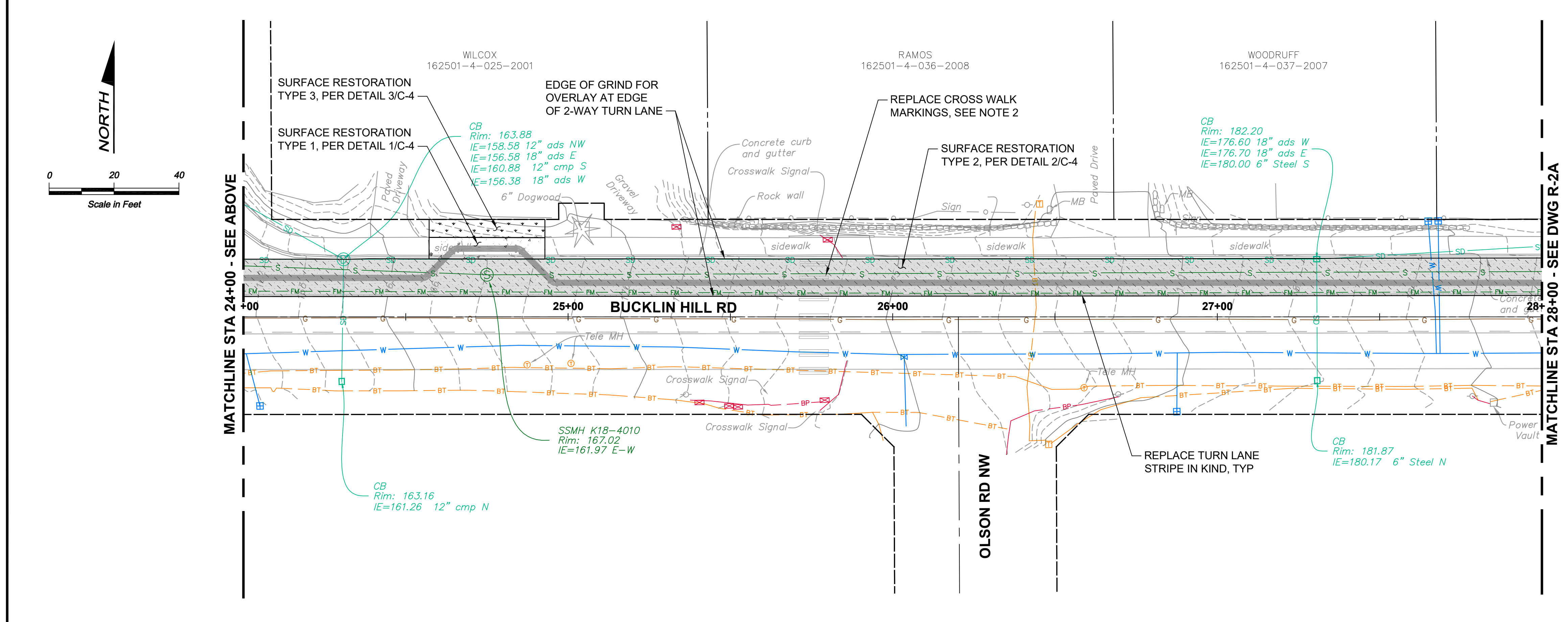

No.	Revision	Date	By	App'd
	ISSUED FOR BID	01-2023	TF	RAD

**bhc CONSULTANTS**  
**BHC Consultants, LLC**  
 1601 Fifth Avenue, Suite 500  
 Seattle, Washington 98101  
 206.505.3400  
 206.505.3406 (fax)  
 www.bhcconsultants.com

Designed: T. Fisher, P.E.  
 Drawn: A. Cariaso  
 Checked: R. Dorn, P.E.

Scale: 1" = 20'-0"  
 One Inch at Full Scale  
 If Not One Inch Scale Accordingly

**Kitsap County Public Works**  
 614 Division Street, MS 26  
 Port Orchard, WA 98366

**SILVERDALE CONVEYANCE SYSTEM AND PUMP STATION 4 UPGRADES**  
 SCHEDULE A  
**BUCKLIN HILL RD RESTORATION PLAN**  
**STA 21+00 TO STA 28+00**

Drawing: **R-1A**  
 Sheet: **22** of **117**  
 File: P21-10530\_R-1A-2A  
 Date: January 2023

Path: S:\Cad\Kitsap County\21-10530 Silverdale Conveyance-PS 4 Uprgr\Design\Drawings\21-10530\_R-1A-2A\_Plot.dwg, Plot date: Jan 06, 2023, 01:39:53pm, CAD User: abradley, Xref Filename: I:\Fisher\1\21-10530\_1B\1\21-10530-SCU\_Extop\1\21-10530-SCU\_Sch A-B\1\21-10530-SCU\_Prop SS | Detail | Palmalter |

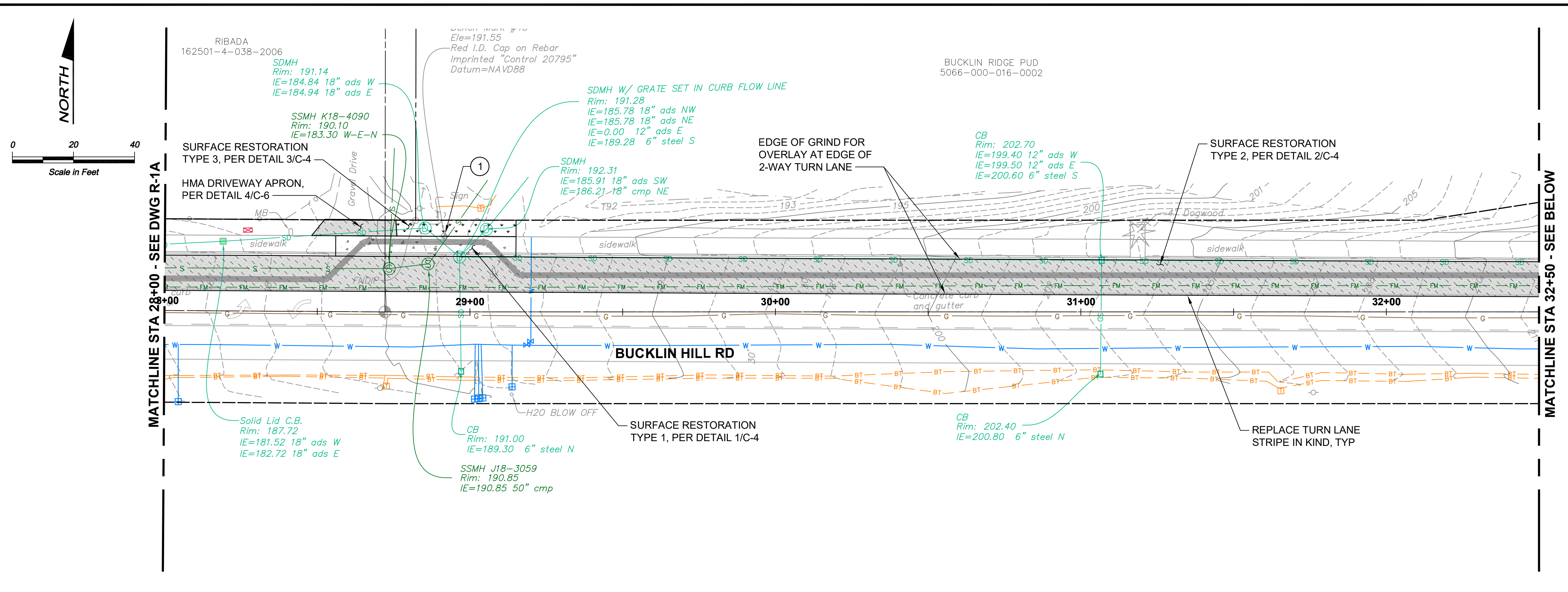

- NOTES:**
- OVERLAY SHALL OCCUPY THE ENTIRE WIDTH OF THE WESTBOUND LANE.
  - REFERENCE STREET CENTERLINE STRIPING, STOP BARS, CROSS WALK STRIPING, AND OTHER SURFACE STREET MARKING PRIOR TO DISTURBING EXISTING AC PAVEMENT. RESTORE ALL MARKINGS IN KIND TO ORIGINAL LOCATIONS AFTER COMPLETION OF FINAL RESTORATION.

- CONSTRUCTION NOTES:**
- PROTECT BENCHMARK/SURVEY MONUMENT. IF THE BENCHMARK/MONUMENT MUST BE DISTURBED, WORK SHALL COMPLY WITH SECTION 1-05.4 OF THE SPECIAL PROVISIONS AND THE WASHINGTON STATE DNR PERMIT TO DESTROY OR REMOVE A SURVEY MONUMENT.

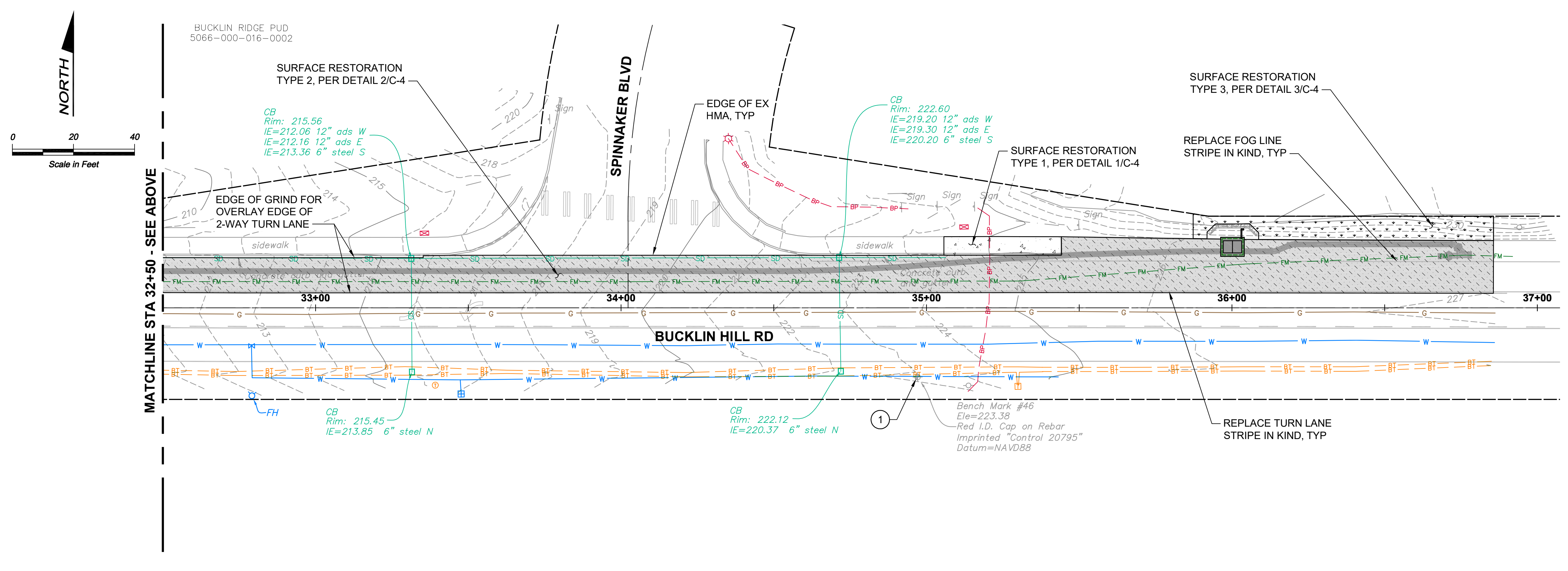

**Call 48 Hours Before You Dig**  
 1-800-424-5555  
 UNDERGROUND SERVICE

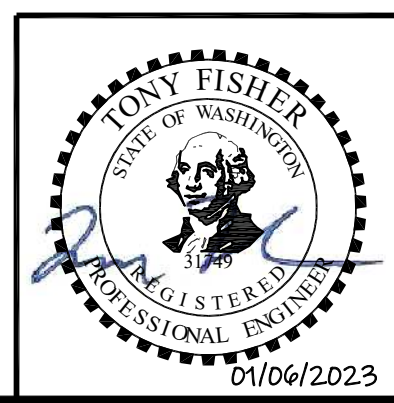

Path: S:\Cadd\Kitsap County\21-10530 Silverdale Conveyance-PS 4 Uprtg\Design\Drawings\21-10530\_P-1A-2A\_Plot.dwg, Jan 06, 2023 01:48:08pm CAD User: abradley.  
 Xref Filename: I:\Fisher\1\21-10530\_1B\1\21-10530-SEC Sch A-B\1\21-10530-SCU Prop SS | Data | Palmiter |

No.	Revision	Date	By	App'd
	ISSUED FOR BID	01-2023	TF	RAD



**BHC CONSULTANTS, LLC**  
 1601 Fifth Avenue, Suite 500  
 Seattle, Washington 98101  
 206.505.3400  
 206.505.3406 (fax)  
 www.bhcconsultants.com

Designed: T. Fisher, P.E.  
 Drawn: A. Cariaso  
 Checked: R. Dorn, P.E.

Scale:  
 1" = 20'-0"  
 One Inch at Full Scale  
 If Not One Inch Scale Accordingly



**Kitsap County Public Works**  
 614 Division Street, MS 26  
 Port Orchard, WA 98366

**SILVERDALE CONVEYANCE SYSTEM AND PUMP STATION 4 UPGRADES**  
 SCHEDULE A  
**BUCKLIN HILL RD**  
**RESTORATION PLAN**  
**STA 28+00 TO STA 37+00**

Drawing: **R-2A**  
 Sheet: **23** of **117**  
 File: P21-10530\_R-1B-2B  
 Date: January 2023

# DETOUR ROUTE FOR FREDRICKSON RD NW

NOT TO SCALE

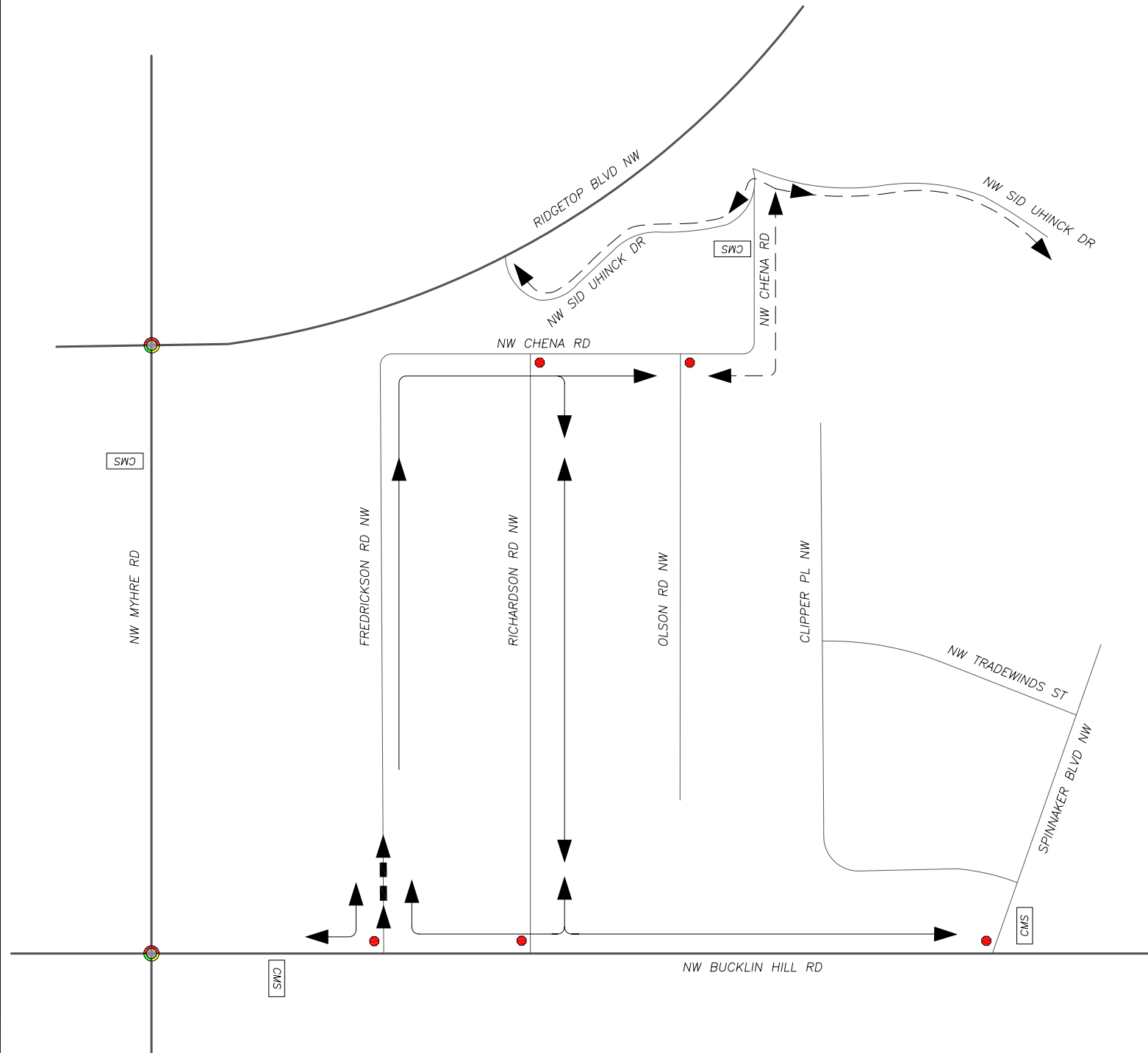

## TRAFFIC CONTROL NOTES – FREDRICKSON RD NW ONLY

1. CONTRACTOR SHALL BE RESPONSIBLE FOR MEANS AND METHODS OF CONSTRUCTION AND SCHEDULING, INCLUDING ALL TRAFFIC CONTROL DURING CONSTRUCTION, AS IDENTIFIED IN THE WSDOT STANDARD SPECIFICATIONS AND AS AMENDED IN THE CONTRACT.
2. CONSTRUCTION ACTIVITY ON ARTERIALS AND LOCAL STREETS IN THE PUBLIC RIGHT OF WAY SHALL BE LIMITED TO WEEKDAYS, AND WORK HOURS SHALL BE ANY CONSECUTIVE 8-HOUR PERIOD BETWEEN 7 AM TO 6 PM. FREDRICKSON RD NW SHALL BE OPENED WITH ONE TRAVEL LANE, FOR ONE-WAY NORTHBOUND TRAFFIC ONLY, DURING THE CONSECUTIVE 8-HOUR PERIOD.
3. THE CONTRACTOR SHALL PROVIDE CHANGEABLE MESSAGE SIGNS (CMS) TO INFORM THE TRAVELING PUBLIC OF UPCOMING CLOSURE AND DETOURS. CMS'S SHALL BE PLACED ALONG THE CONSTRUCTION ROUTE AND DETOUR ROUTE AT LEAST TWO WEEKS IN ADVANCE OF CLOSURE. CMS'S SHALL BE LOCATED, AT A MINIMUM, AT THE LOCATIONS SHOWN ON THIS SHEET.
4. THE CONTRACTOR SHALL PROVIDE FOR PEDESTRIAN ACCESS AROUND OR THROUGH CONSTRUCTION WORK AT ALL TIMES.
5. THE CONTRACTOR SHALL POST MOTORCYCLE SUPPLEMENTAL WARNING SIGNS FOR WORK ZONES WITH STEEL PLATES OR UNEVEN ROADWAY SURFACE.
6. THE CONTRACTOR SHALL COORDINATE WITH EMERGENCY SERVICE PROVIDER, CENTRAL KITSAP SCHOOL DISTRICT, KITSAP TRANSIT, PARATRANSIT SERVICES, AND PORTAL SERVICE AT LEAST TWO WEEKS PRIOR TO ANY CHANGE TO TRAFFIC CONTROL.
7. DURING LANE CLOSURE THE CONTRACTOR SHALL MAINTAIN LOCAL ACCESS TO ALL PROPERTIES IN THE CLOSED AREA AND MAINTAIN ONE MINIMUM 10' TRAVEL LANE THROUGH WORK ZONE.
8. CONSTRUCTION WORK AREA WILL INCLUDE THE NORTHBOUND TRAVEL LANE FOR FREDRICKSON RD NW NEAR THE NW BUCKLIN HILL RD AND FREDRICKSON RD NW INTERSECTION.

TRAFFIC CONTROL PLAN LEGEND	
DESCRIPTION	
	ONE WAY ROUTE
	SIGNED DETOUR
	STOP SIGN
	TRAFFIC SIGNAL
	CHANGEABLE MESSAGE SIGN
	ALTERNATIVE ROUTE



**Call 48 Hours Before You Dig**

**1-800-424-5555**  
UNDERGROUND SERVICE



07-06-2023

No.	Revision	Date	By	App'd

**bhc**  
CONSULTANTS  
BHC Consultants, LLC  
1601 Fifth Avenue, Suite 500  
Seattle, Washington 98101  
206.505.3400  
206.505.3406 (fax)  
www.bhcconsultants.com

**TENW**  
Transportation Engineering NorthWest  
Transportation Planning | Design | Traffic Impact & Operations  
11400 SE 8th Street, Suite 200, Bellevue, WA 98004 | Office (425) 889-4747  
Project Contact: Trevin Roletto, P.E.  
Phone: 425-250-0583

Designed: TDR  
Drawn: TDR  
Checked: EMS  
Scale: N.T.S.  
One Inch At Full Scale  
If Not One Inch Scale Accordingly

**Kitsap County Public Works**  
614 Division Street, MS 26  
Port Orchard, WA 98366

**SILVERDALE CONVEYANCE SYSTEM AND PUMP STATION 4 UPGRADES**  
SCHEDULE A  
TRAFFIC CONTROL PLANS  
FREDRICKSON RD NW

Drawing:	TC-1A
Sheet:	24 of 117
File:	KP-MASTER TCP
Date:	JANUARY 2023



# DETOUR ROUTE FOR NW BUCKLIN HILL RD

NOT TO SCALE

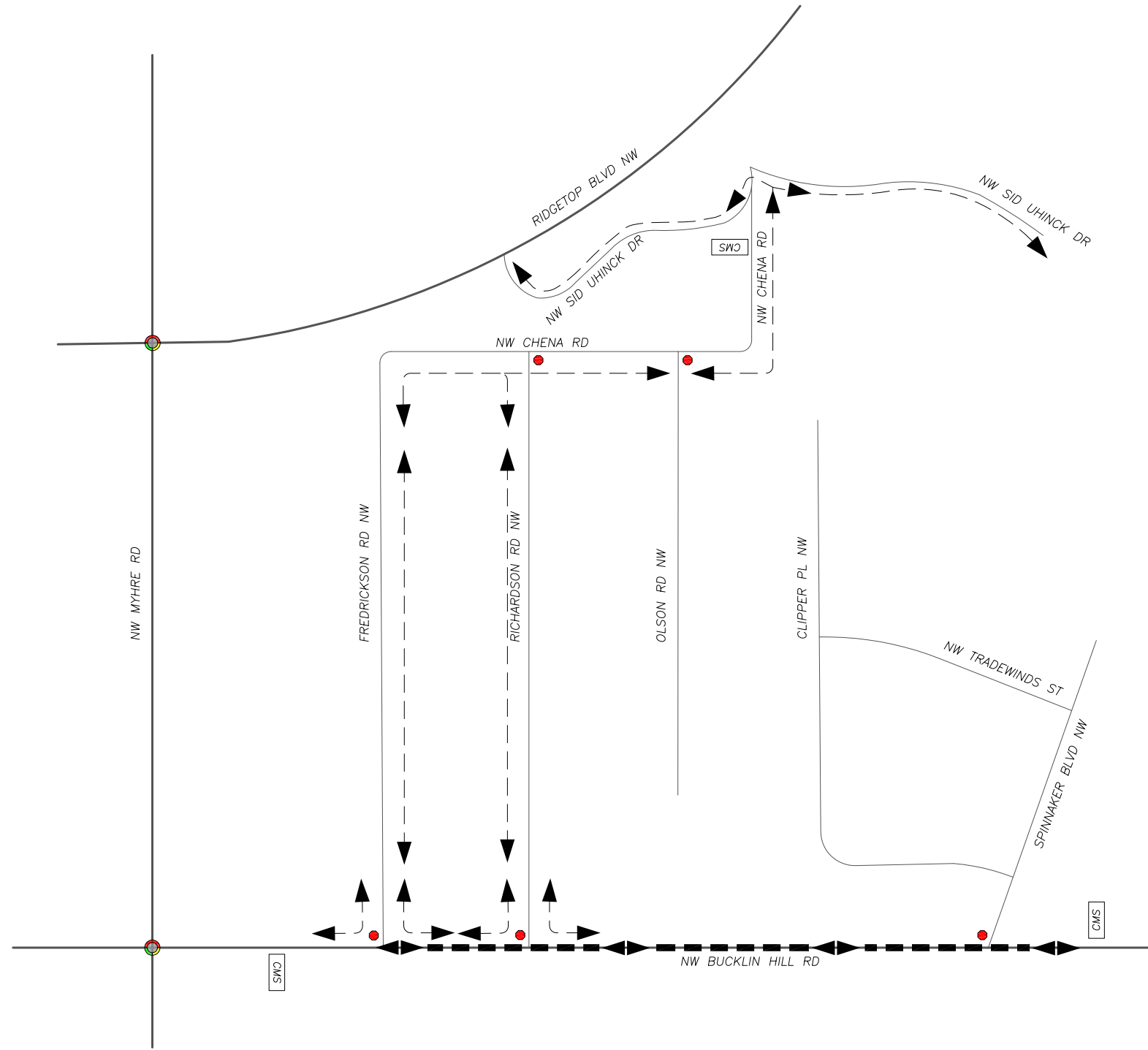

## TRAFFIC CONTROL NOTES – NW BUCKLIN HILL RD ONLY

1. CONTRACTOR SHALL BE RESPONSIBLE FOR MEANS AND METHODS OF CONSTRUCTION AND SCHEDULING, INCLUDING ALL TRAFFIC CONTROL DURING CONSTRUCTION, AS IDENTIFIED IN THE WSDOT STANDARD SPECIFICATIONS AND AS AMENDED IN THE CONTRACT.
2. CONSTRUCTION ACTIVITY ON ARTERIALS AND LOCAL STREETS IN THE PUBLIC RIGHT OF WAY SHALL BE LIMITED TO WEEKDAYS, AND WORK HOURS SHALL BE ANY CONSECUTIVE 8-HOUR PERIOD BETWEEN 7 AM TO 6 PM. NW BUCKLIN HILL RD SHALL BE OPENED WITH TWO TRAVEL LANES FOR TWO-WAY TRAFFIC (WESTBOUND AND EASTBOUND) DURING THE CONSECUTIVE 8-HOUR PERIOD.
3. THE CONTRACTOR SHALL PROVIDE CHANGEABLE MESSAGE SIGNS (CMS) TO INFORM THE TRAVELING PUBLIC OF UPCOMING CLOSURE AND DETOURS. CMS'S SHALL BE PLACED ALONG THE CONSTRUCTION ROUTE AND DETOUR ROUTE AT LEAST TWO WEEKS IN ADVANCE OF CLOSURE. CMS'S SHALL BE LOCATED, AT A MINIMUM, AT THE LOCATIONS SHOWN ON THIS SHEET.
4. THE CONTRACTOR SHALL PROVIDE FOR PEDESTRIAN ACCESS AROUND OR THROUGH CONSTRUCTION WORK AT ALL TIMES.
5. THE CONTRACTOR SHALL POST MOTORCYCLE SUPPLEMENTAL WARNING SIGNS FOR WORK ZONES WITH STEEL PLATES OR UNEVEN ROADWAY SURFACE.
6. THE CONTRACTOR SHALL COORDINATE WITH EMERGENCY SERVICE PROVIDER, CENTRAL KITSAP SCHOOL DISTRICT, KITSAP TRANSIT, PARATRANSIT SERVICES, AND PORTAL SERVICE AT LEAST TWO WEEKS PRIOR TO ANY CHANGE TO TRAFFIC CONTROL.
7. DURING LANE CLOSURE THE CONTRACTOR SHALL MAINTAIN LOCAL ACCESS TO ALL PROPERTIES IN THE CLOSED AREA AND MAINTAIN ONE MINIMUM 10' TRAVEL LANE THROUGH WORK ZONE.
8. THE TWO-WAY LEFT TURN LANE SHALL BE USED FOR WESTBOUND TRAFFIC, ALONG NW BUCKLIN HILL RD, DURING CONSTRUCTION WITH CHANNELIZING DEVICES. IF NEEDED, FLAGGER CONTROL SHALL BE USED TO MAINTAIN TWO-WAY TRAFFIC ALONG NW BUCKLIN HILL RD.

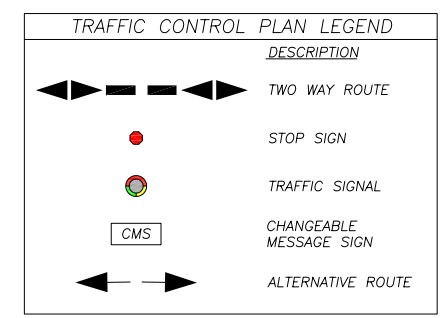

**Call 48 Hours Before You Dig**  
 1-800-424-5555  
 UNDERGROUND SERVICE

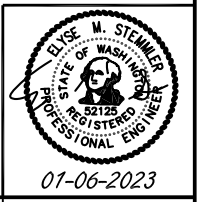

No.	Revision	Date	By	App'd

**bhc**  
**CONSULTANTS**  
 BHC Consultants, LLC  
 1601 Fifth Avenue, Suite 500  
 Seattle, Washington 98101  
 206.505.3400  
 206.505.3406 (fax)  
 www.bhcconsultants.com

**TENW**  
 Transportation Engineering NorthWest  
 Transportation Planning | Design | Traffic Impact & Operations  
 11400 SE 8th Street, Suite 200, Bellevue, WA 98004 | Office (425) 889-4747  
 Project Contact: Trevin Roletto, P.E.  
 Phone: 425-250-0583

Designed: TDR  
 Drawn: TDR  
 Checked: EMS  
 Scale: N.T.S.  
 One Inch At Full Scale  
 If Not One Inch Scale Accordingly

**Kitsap County Public Works**  
 614 Division Street, MS 26  
 Port Orchard, WA 98366

**SILVERDALE CONVEYANCE SYSTEM AND PUMP STATION 4 UPGRADES**  
**SCHEDULE A**  
**TRAFFIC CONTROL PLANS**  
**NW BUCKLIN HILL RD**

Drawing:	TC-2A
Sheet:	25 of 117
File:	KP-MASTER TCP
Date:	JANUARY 2023

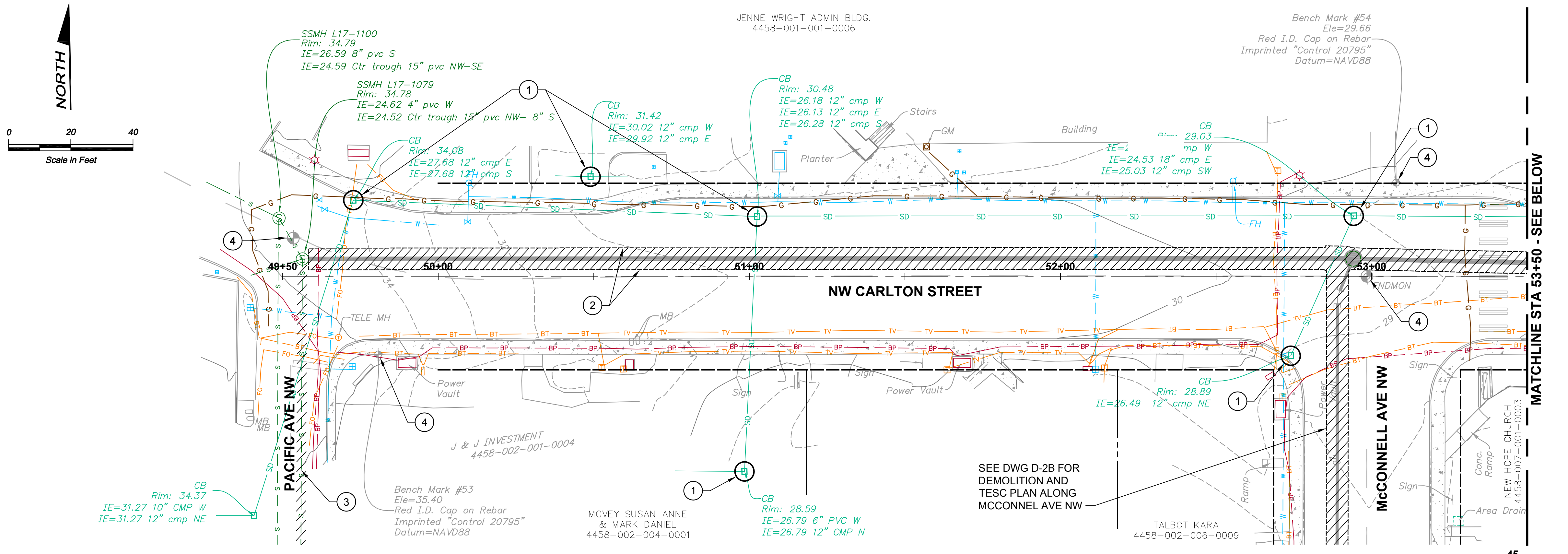

- NOTES:**
- FOR ALL SURFACES SUBJECT TO VEHICULAR TRAFFIC, RESTORE DISTURBED AREA WITH 1" MINIMUM TEMPORARY HMA PATCH AND TEMPORARY STRIPING BY THE END OF EACH WORK DAY. MAINTAIN TEMPORARY HMA PATCH AND TEMPORARY STRIPING UNTIL REPLACED WITH PERMANENT HMA PATCH AND STRIPING.

- CONSTRUCTION NOTES:**
- INSTALL CATCH BASIN INSERT, PER DETAIL 3/C-1.
  - SAWCUT AND REMOVE FULL DEPTH OF EX HMA, SEE NOTE 1 ABOVE.
  - ABANDON EXISTING 8" SANITARY SEWER FROM SANITARY SEWER MANHOLE L17-1079 TO L17-1078 (APPROXIMATELY 144 FEET) PER SPECIAL PROVISIONS.
  - PROTECT BENCHMARK/SURVEY MONUMENT. IF THE BENCHMARK/MONUMENT MUST BE DISTURBED, WORK SHALL COMPLY WITH SECTION 1-05.4 OF THE SPECIAL PROVISIONS AND THE WASHINGTON STATE DNR PERMIT TO DESTROY OR REMOVE A SURVEY MONUMENT.

MATCHLINE STA 53+50 - SEE BELOW

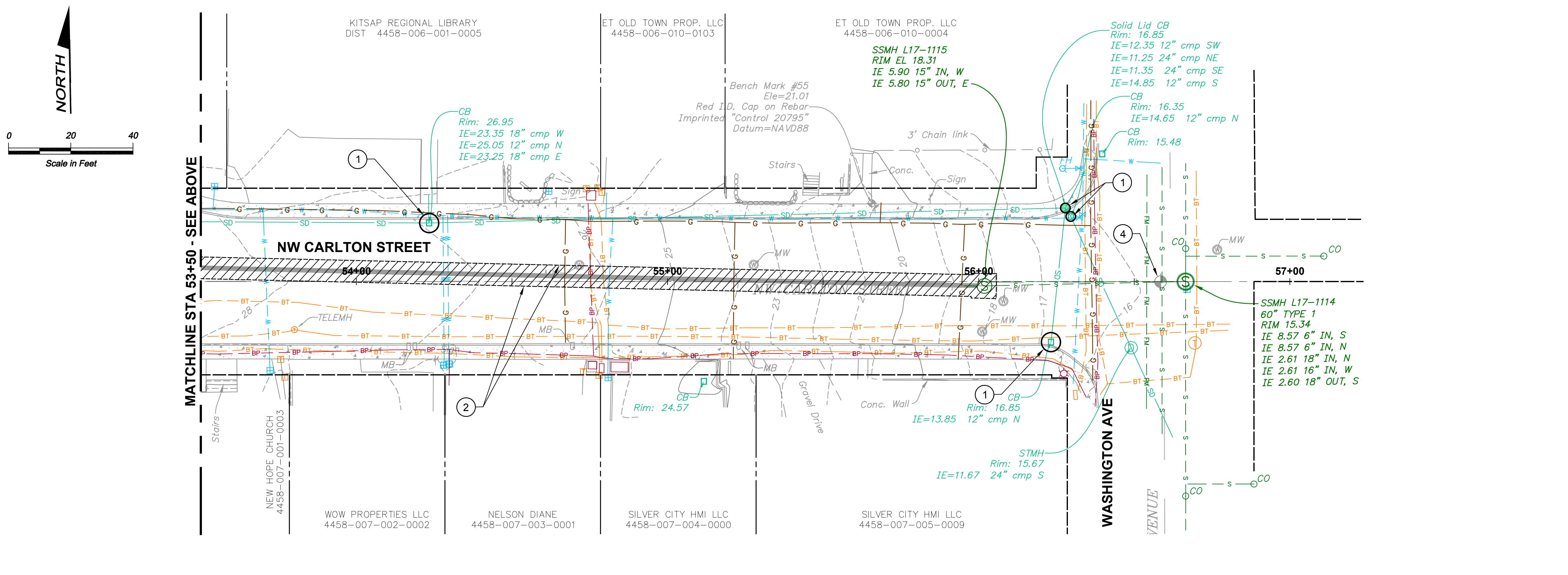

MATCHLINE STA 53+50 - SEE ABOVE

**Call 48 Hours Before You Dig**  
 1-800-424-5555  
 UNDERGROUND SERVICE

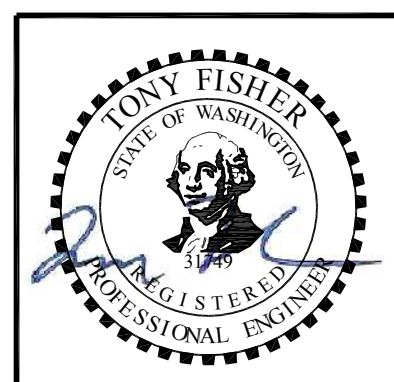

Path: S:\Cad\Kitsap County\21-10530 Silverdale Conveyance-PS 4 Uprtg\Design\Drawings\21-10530\_D-1B-2B\_Plot.dwg, Jan 06, 2023 03:31:12pm, CAD User: solose, Xref Filename: X21-10530-SCU\_Ext\_Topo Old Town | X21-10530\_TB | Fisher | X21-10530-SCU\_Prop SS | Dant | Palmlatter |

No.	Revision	Date	By	App'd
	ISSUED FOR BID	01-2023	TF	RAD

**bhc CONSULTANTS**  
 BHC Consultants, LLC  
 1601 Fifth Avenue, Suite 500  
 Seattle, Washington 98101  
 206.505.3400  
 206.505.3406 (fax)  
 www.bhcconsultants.com

Designed: T. Fisher, P.E.  
 Drawn: A. Cariaso  
 Checked: R. Dorn, P.E.

Scale:  
 Horiz: 1" = 20'-0"  
 Vert: 1" = 5'-0"  
 One Inch at Full Scale  
 If Not One Inch Scale Accordingly

**Kitsap County Public Works**  
 614 Division Street, MS 26  
 Port Orchard, WA 98366

**SILVERDALE CONVEYANCE SYSTEM AND PUMP STATION 4 UPGRADES SCHEDULE B**  
**NW CARLTON STREET DEMOLITION AND TESC PLAN STA 49+50 TO STA 56+50**

Drawing: **D-1B**  
 Sheet: **26** of **117**  
 File: P21-10530\_D-1B-2B  
 Date: January 2023

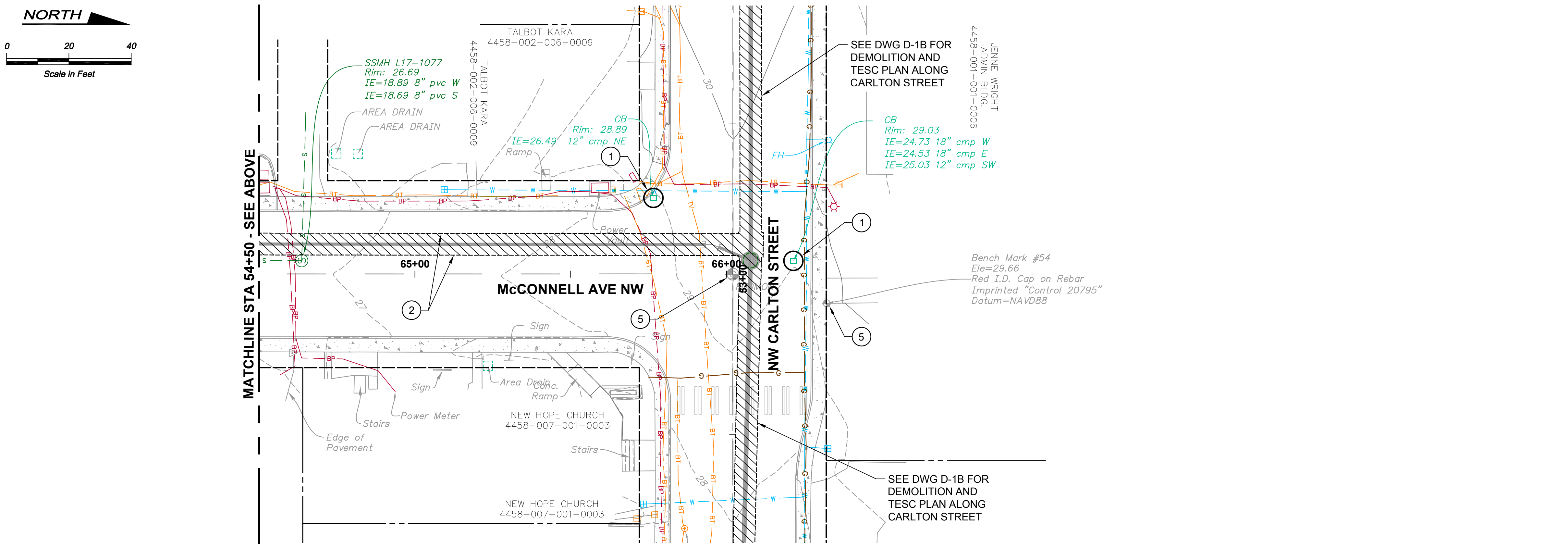
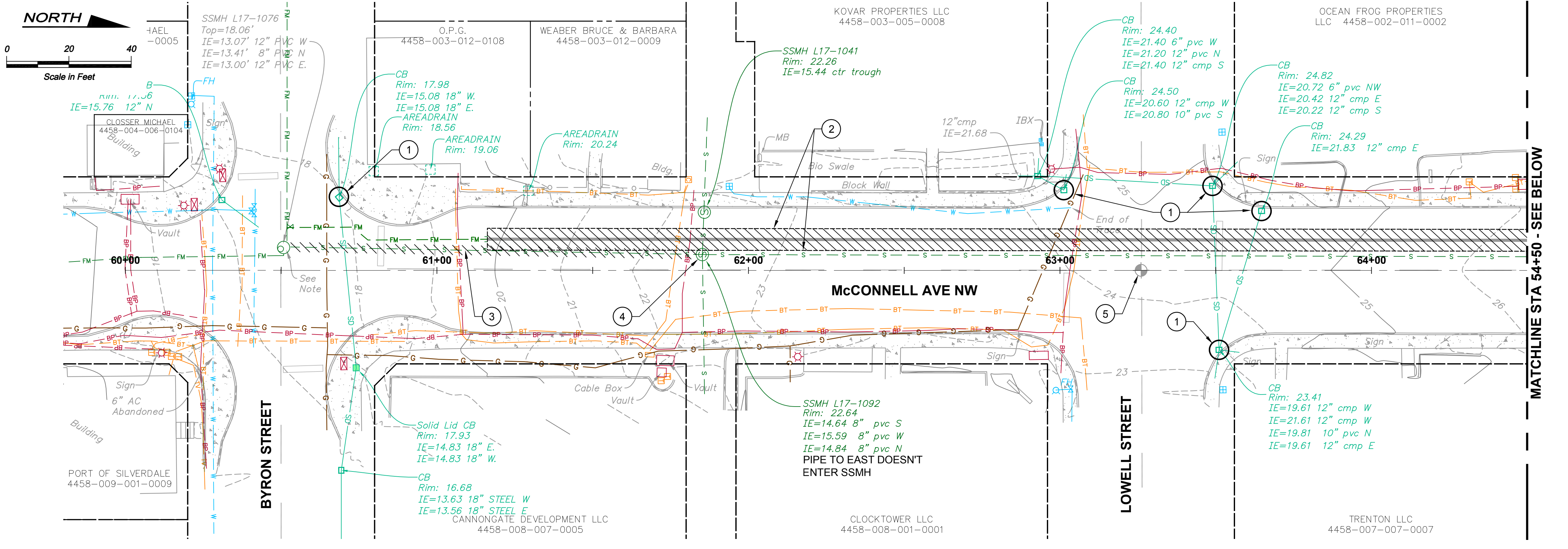

- NOTES:**
- FOR ALL SURFACES SUBJECT TO VEHICULAR TRAFFIC, RESTORE DISTURBED AREA WITH 1" MINIMUM TEMPORARY HMA PATCH AND TEMPORARY STRIPING BY THE END OF EACH WORK DAY. MAINTAIN TEMPORARY HMA PATCH AND TEMPORARY STRIPING UNTIL REPLACED WITH PERMANENT HMA PATCH AND STRIPING.
- CONSTRUCTION NOTES:**
- INSTALL CATCH BASIN INSERT, PER DETAIL 3/C-1
  - SAWCUT AND REMOVE FULL DEPTH OF EXISTING HMA, SEE NOTE 1 ABOVE.
  - ABANDON EXISTING 8" SANITARY SEWER PER SPECIAL PROVISIONS
  - PLUG 8" OUTLET TO SOUTH AND RECHANNEL EXISTING SANITARY SEWER MANHOLE TO DIRECT ALL INCOMING FLOW TO EAST OUTLET.
  - PROTECT BENCHMARK/SURVEY MONUMENT. IF THE BENCHMARK/MONUMENT MUST BE DISTURBED, WORK SHALL COMPLY WITH SECTION 1-05.4 OF THE SPECIAL PROVISIONS AND THE WASHINGTON STATE DNR PERMIT TO DESTROY OR REMOVE A SURVEY MONUMENT.

Path: S:\CAD\Kitsap County\21-10530 Silverdale Conveyance-PS 4 Uprg\Design\Drawings\21-10530\_D-1B-2B\_Plot.dwg; Plot date: Jan 06, 2023 03:32:50pm; CAD User: selsee; Xref Filename: \\X21-10530-SCU\_Ext\Topo Old Town\X21-10530\_TB\Fisher\X21-10530-SCU\_Prop SS | Dant | Palmlatter |

**Call 48 Hours Before You Dig**  
**1-800-424-5555**  
 UNDERGROUND SERVICE



**BHC CONSULTANTS, LLC**  
 1601 Fifth Avenue, Suite 500  
 Seattle, Washington 98101  
 206.505.3400  
 206.505.3406 (fax)  
 www.bhcconsultants.com

Designed: T. Fisher, P.E.  
 Drawn: A. Cariaso  
 Checked: R. Dorn, P.E.

Scale:  
 Horiz: 1" = 20'-0"  
 Vert: 1" = 5'-0"  
 One Inch at Full Scale  
 If Not One Inch Scale Accordingly



**Kitsap County Public Works**  
 614 Division Street, MS 26  
 Port Orchard, WA 98366

**SILVERDALE CONVEYANCE SYSTEM AND PUMP STATION 4 UPGRADES**  
**SCHEDULE B**  
**McCONNELL AVE NW**  
**DEMOLITION AND TESC PLAN**  
**STA 60+00 TO STA 66+50**

Drawing: **D-2B**  
 Sheet: **27** of **117**  
 File: P21-10530\_D-1B-2B  
 Date: January 2023

Path: S:\CAD\Kitsap County\21-10530 Silverdale Conveyance\PS 4 Uprgr\Design\Drawings\DWG\21-10530-SCU\_C-1B-4B\_Plan.dwg, Jan 06, 2023 01:47:19pm CAD User: Jura  
 Xref Filename: 21-10530-SCU\_Ext Topo Old Town\21-10530-SCU\_Ext Topo SS\21-10530-SCU\_Ext Align\Prof\21-10530-SCU\_Ext Topo\Palmetier\

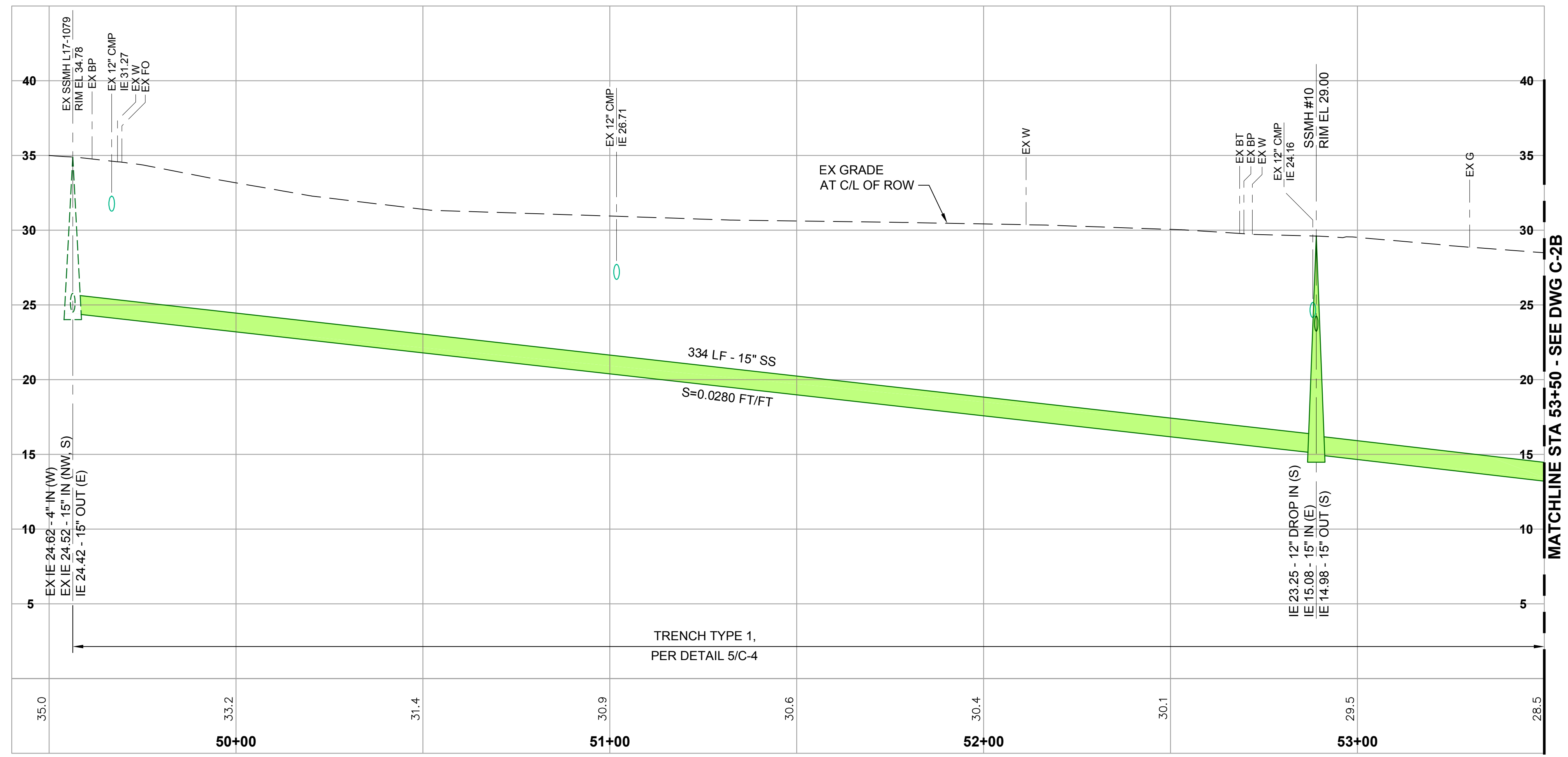
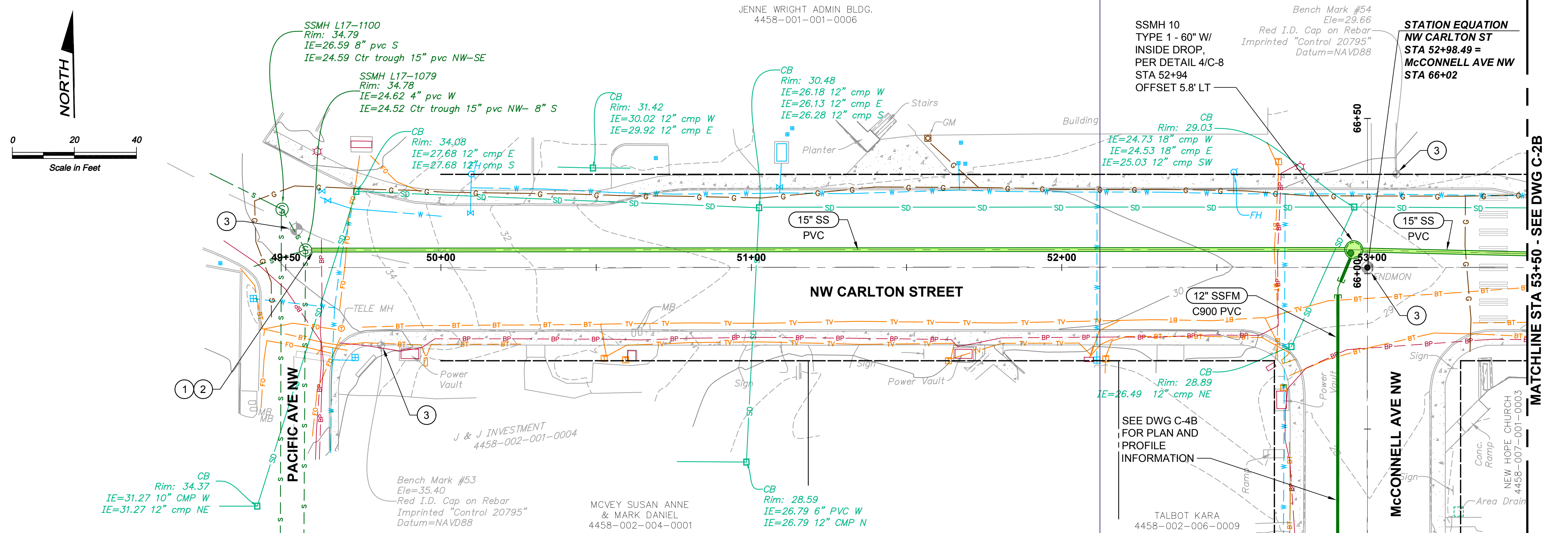

MATCHLINE STA 53+50 - SEE DWG C-2B

**NOTES:**

- FOR ALL SURFACES SUBJECT TO VEHICULAR TRAFFIC, RESTORE DISTURBED AREA WITH 1" MINIMUM TEMPORARY HMA PATCH AND TEMPORARY STRIPING BY THE END OF EACH WORK DAY. MAINTAIN TEMPORARY HMA PATCH AND TEMPORARY STRIPING UNTIL REPLACED WITH PERMANENT HMA PATCH AND STRIPING.
- NOTED LENGTHS OF PIPE IN PROFILE ARE FROM WALL OF SSMH WITH SLOPES CALCULATED ACCORDINGLY.

**CONSTRUCTION NOTES:**

- CONNECT NEW 15" SS TO EXISTING SSMH L17-1079 BY CORING NEW MANHOLE ENTRANCE AND INSTALLING A TYPE 1 WALL PENETRATION PER DETAIL 7/C-7. PLUG OUTLET TO THE SOUTH AND RECHANNEL SSMH L17-1079 TO DIRECT ALL FLOW TO THE EAST.
- BYPASS FLOWS AS NECESSARY TO FACILITATE CONNECTIONS TO THE EXISTING SANITARY SEWER SYSTEM. SEE SHEET G-4 AND THE SPECIAL PROVISIONS FOR ADDITIONAL INFORMATION REGARDING BYPASS REQUIREMENTS.
- PROTECT BENCHMARK/SURVEY MONUMENT. IF THE BENCHMARK/ MONUMENT MUST BE DISTURBED, WORK SHALL COMPLY WITH SECTION 1-05.4 OF THE SPECIAL PROVISIONS AND THE WASHINGTON STATE DNR PERMIT TO DESTROY OR REMOVE A SURVEY MONUMENT.

**Call 48 Hours Before You Dig**  
 1-800-424-5555  
 UNDERGROUND SERVICE

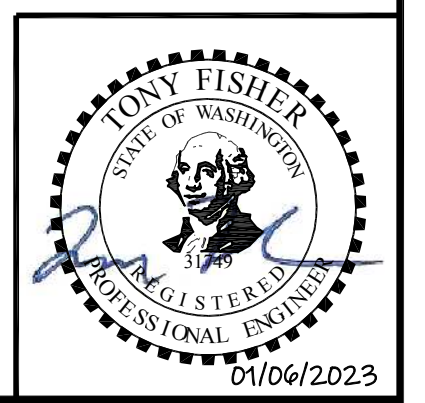

**bhc CONSULTANTS**  
 BHC Consultants, LLC  
 1601 Fifth Avenue, Suite 500  
 Seattle, Washington 98101  
 206.505.3400  
 206.505.3406 (fax)  
 www.bhcconsultants.com

Designed: T. Fisher, P.E.  
 Drawn: G. Castillo  
 Checked: R. Dorn, P.E.

Scale:  
 Horiz: 1" = 20'-0"  
 Vert: 1" = 5'-0"  
 One Inch at Full Scale  
 If Not One Inch Scale Accordingly

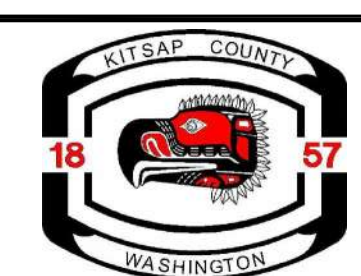

**Kitsap County Public Works**  
 614 Division Street, MS 26  
 Port Orchard, WA 98366

**SILVERDALE CONVEYANCE SYSTEM AND PUMP STATION 4 UPGRADES**  
 SCHEDULE B  
**NW CARLTON STREET**  
**PLAN AND PROFILE**  
**STA 49+50 TO STA 53+50**

Drawing: **C-1B**  
 Sheet: **28** of **117**  
 File: P21-10530\_C-1B-4B  
 Date: January 2023

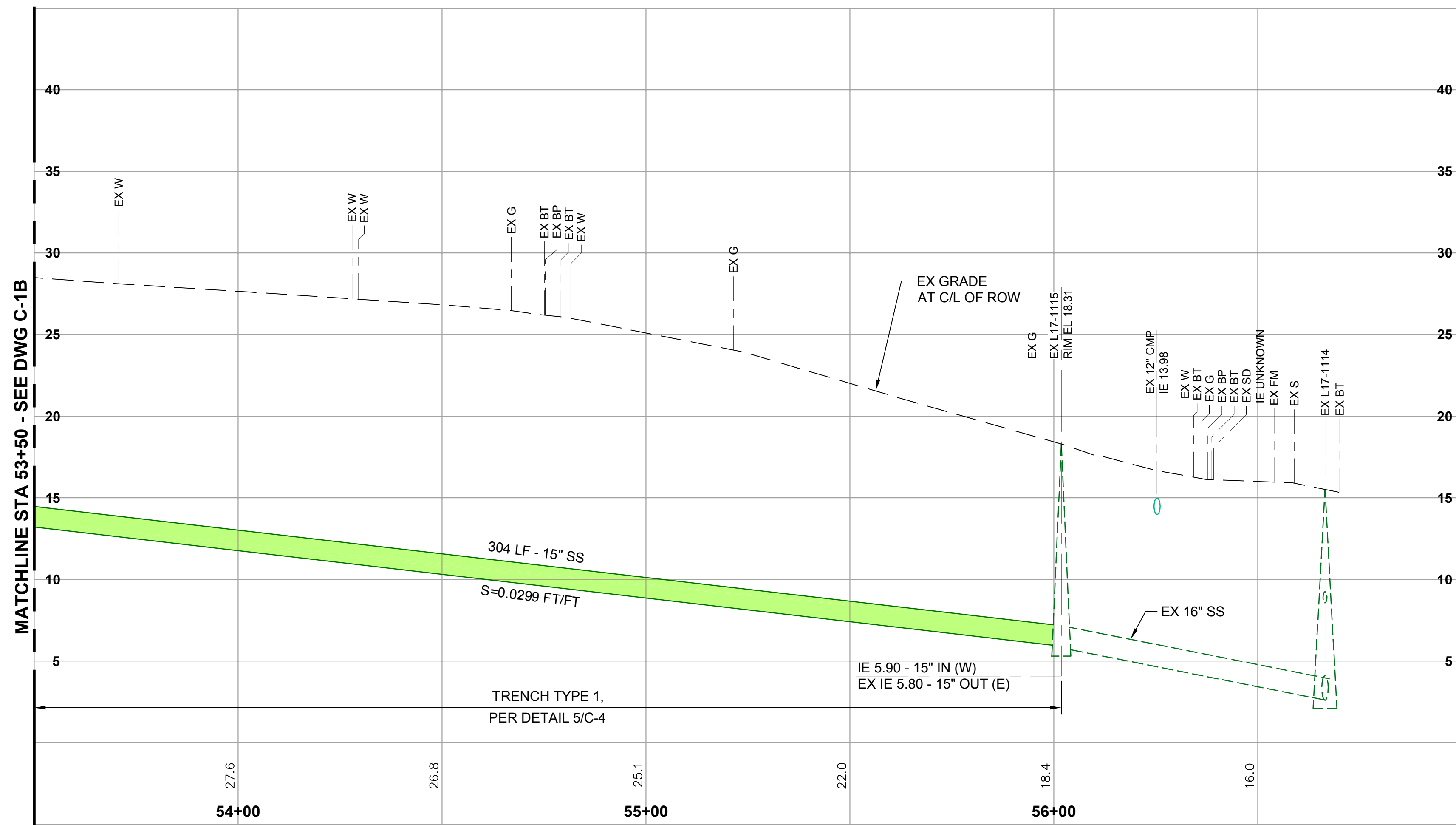
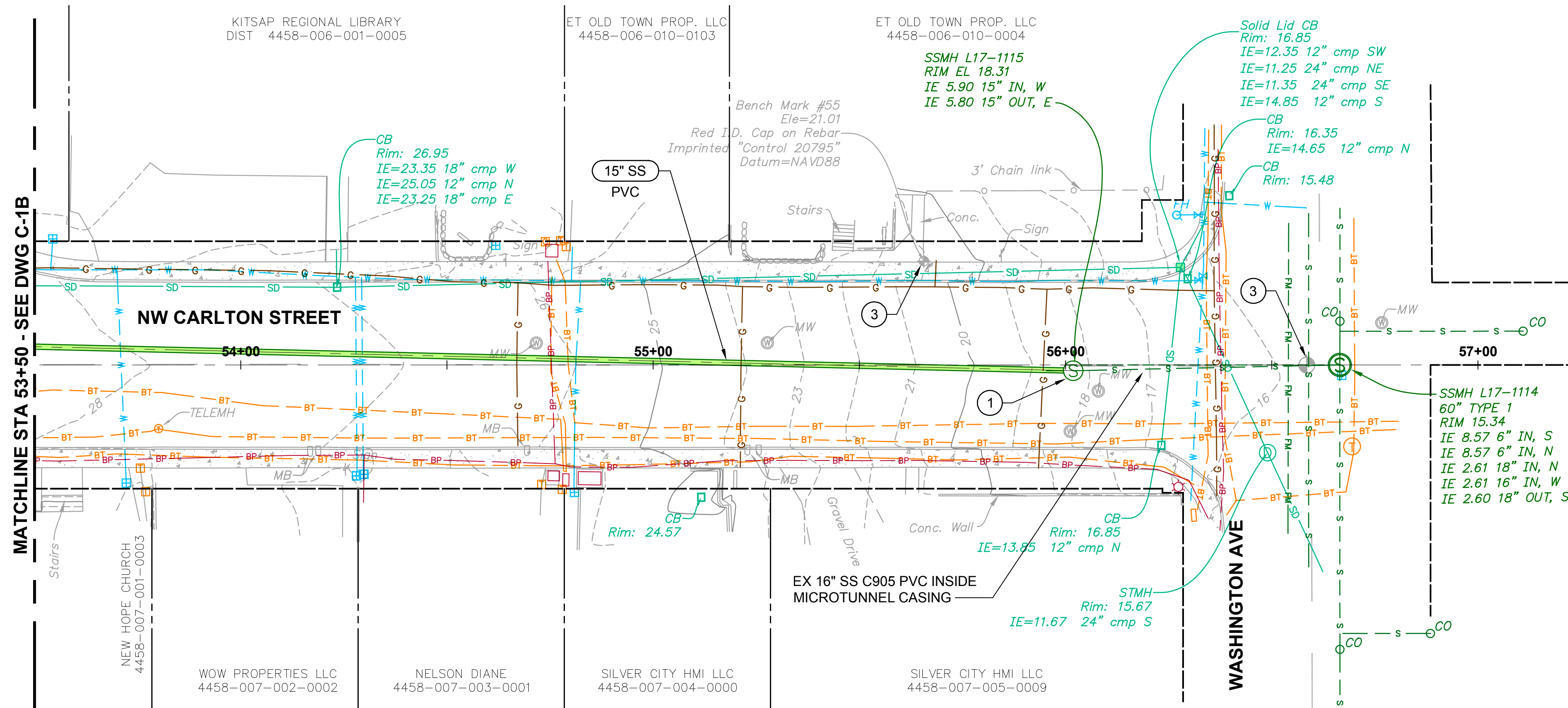
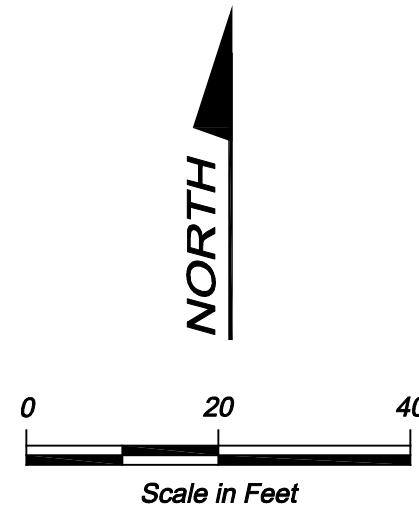

**NOTES:**

- FOR ALL SURFACES SUBJECT TO VEHICULAR TRAFFIC, RESTORE DISTURBED AREA WITH 1" MINIMUM TEMPORARY HMA PATCH AND TEMPORARY STRIPING BY THE END OF EACH WORK DAY. MAINTAIN TEMPORARY HMA PATCH AND TEMPORARY STRIPING UNTIL REPLACED WITH PERMANENT HMA PATCH AND STRIPING.
- BYPASS FLOWS AS NECESSARY TO FACILITATE CONNECTIONS TO THE EXISTING SANITARY SEWER SYSTEM. SEE SHEET G-4 AND THE SPECIAL PROVISIONS FOR ADDITIONAL INFORMATION REGARDING BYPASS REQUIREMENTS.

**CONSTRUCTION NOTES:**

- CONNECT NEW 15" SS TO EXISTING SSMH L17-1115 BY CORING NEW MANHOLE ENTRANCE AND INSTALLING A TYPE 1 WALL PENETRATION PER DETAIL 7/C-7. CHANNEL MANHOLE AS NECESSARY.
- BYPASS FLOWS AS NECESSARY TO FACILITATE CONNECTIONS TO THE EXISTING SANITARY SEWER SYSTEM. SEE SHEET G-4 AND THE SPECIAL PROVISIONS FOR ADDITIONAL INFORMATION REGARDING BYPASS REQUIREMENTS.
- PROTECT BENCHMARK/SURVEY MONUMENT. IF THE BENCHMARK/ MONUMENT MUST BE DISTURBED, WORK SHALL COMPLY WITH SECTION 1-05.4 OF THE SPECIAL PROVISIONS AND THE WASHINGTON STATE DNR PERMIT TO DESTROY OR REMOVE A SURVEY MONUMENT.

**Call 48 Hours Before You Dig**

**1-800-424-5555**  
UNDERGROUND SERVICE

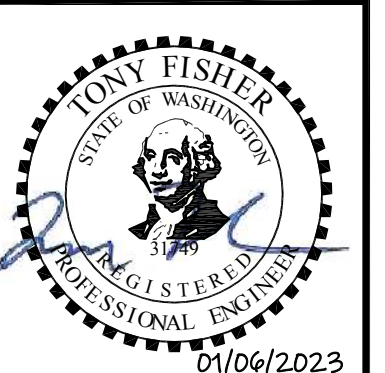

**bhc**  
CONSULTANTS

**BHC Consultants, LLC**  
1601 Fifth Avenue, Suite 500  
Seattle, Washington 98101  
206.505.3400  
206.505.3406 (fax)  
www.bhcconsultants.com

Designed: T. Fisher, P.E.  
Drawn: G. Castillo  
Checked: R. Dorn, P.E.

Scale:  
Horiz: 1" = 20'-0"  
Vert: 1" = 5'-0"  
One Inch at Full Scale  
If Not One Inch Scale Accordingly



**Kitsap County Public Works**  
614 Division Street, MS 26  
Port Orchard, WA 98366

**SILVERDALE CONVEYANCE SYSTEM AND PUMP STATION 4 UPGRADES**  
SCHEDULE B

**NW CARLTON STREET**  
**PLAN AND PROFILE**  
**STA 53+50 TO STA 56+50**

Drawing: **C-2B**  
Sheet: **29** of **117**  
File: P21-10530\_C-1B-4B  
Date: January 2023

Path: S:\Cadd\Kitsap County\21-10530 Silverdale Conveyance-PS 4 Uprgr\Design\Drawings\DWG\21-10530-SCU\_Exp Align-Proj\21-10530-SCU\_Exp Topo | Palmatier | Jura

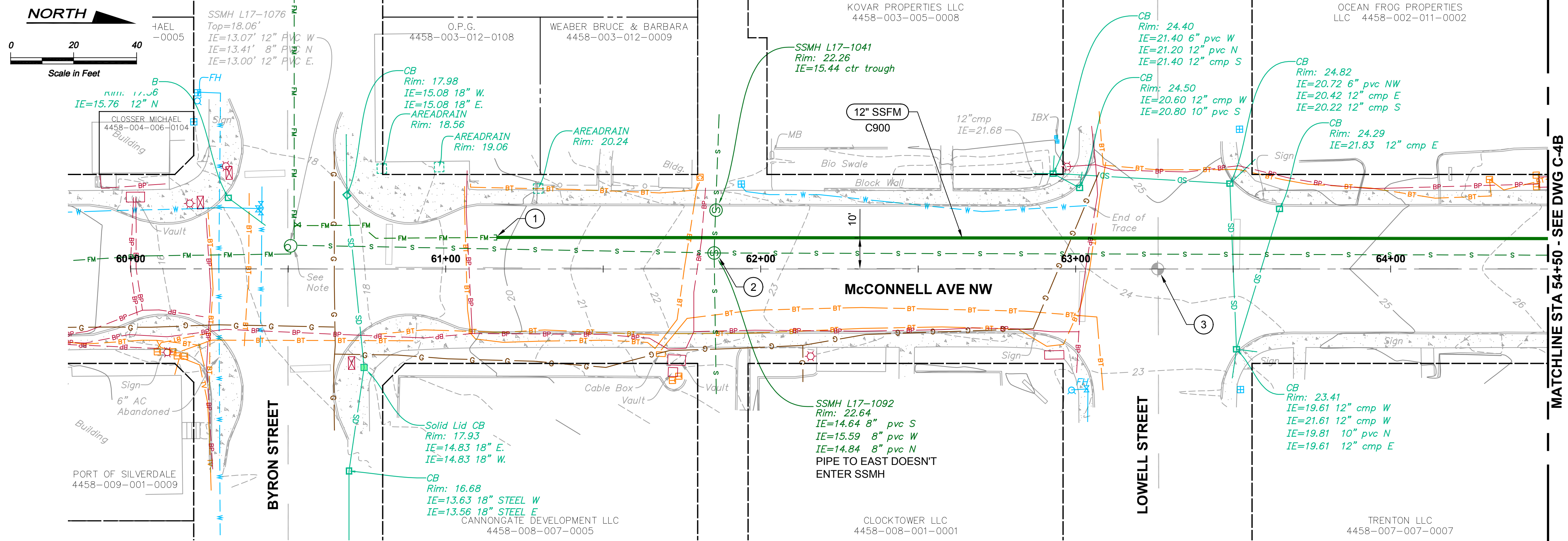

- NOTES:**
1. MAINTAIN POSITIVE SLOPE ON THE FORCE MAIN AND AVOID HIGH AND LOW POINTS UNLESS SPECIFICALLY CALL OUT.
  2. DEFLECT PIPE VERTICALLY PER MANUFACTURER'S RECOMMENDATIONS TO SMOOTHLY TRANSITION GRADE WHILE ADHERING TO COVER REQUIREMENTS.
  3. FOR ALL SURFACES SUBJECT TO VEHICULAR TRAFFIC, RESTORE DISTURBED AREAS WITH 1" MIN TEMPORARY HMA PATCH AND TEMP STRIPING BY THE END OF EACH WORK DAY. MAINTAIN TEMP HMA PATCH AND TEMP STRIPING UNTIL IT IS REPLACED WITH THE PERMANENT RESTORATION.
  4. POTHOLE EXISTING UTILITIES AS NECESSARY TO VERIFY INVERTS PRIOR TO CONSTRUCTING FORCE MAIN TO ALLOW ADJUSTMENTS TO FORCE MAIN DEPTH TO MAINTAIN AT LEAST 12 INCHES OF VERTICAL SEPARATION.
  5. ALL MJ FITTINGS SHALL BE RESTRAINED AND HAVE THRUST BLOCKS.

- CONSTRUCTION NOTES:**
- 1 REMOVE EX CAP AND CONNECT NEW 12" SSFM TO EX 12" SSFM WITH ROMAC ALPHA RESTRAINED COUPLING OR ACCEPTED EQUAL.
  - 2 RECHANNEL SSMH L17-1092 TO DIRECT ALL INCOMING FLOW INTO THE EAST OUTLET. PLUG THE SOUTH OUTLET PRIOR TO RECHANNELING THE MANHOLE.
  - 3 PROTECT BENCHMARK/SURVEY MONUMENT. IF THE BENCHMARK/ MONUMENT MUST BE DISTURBED, WORK SHALL COMPLY WITH SECTION 1-05.4 OF THE SPECIAL PROVISIONS AND THE WASHINGTON STATE DNR PERMIT TO DESTROY OR REMOVE A SURVEY MONUMENT.

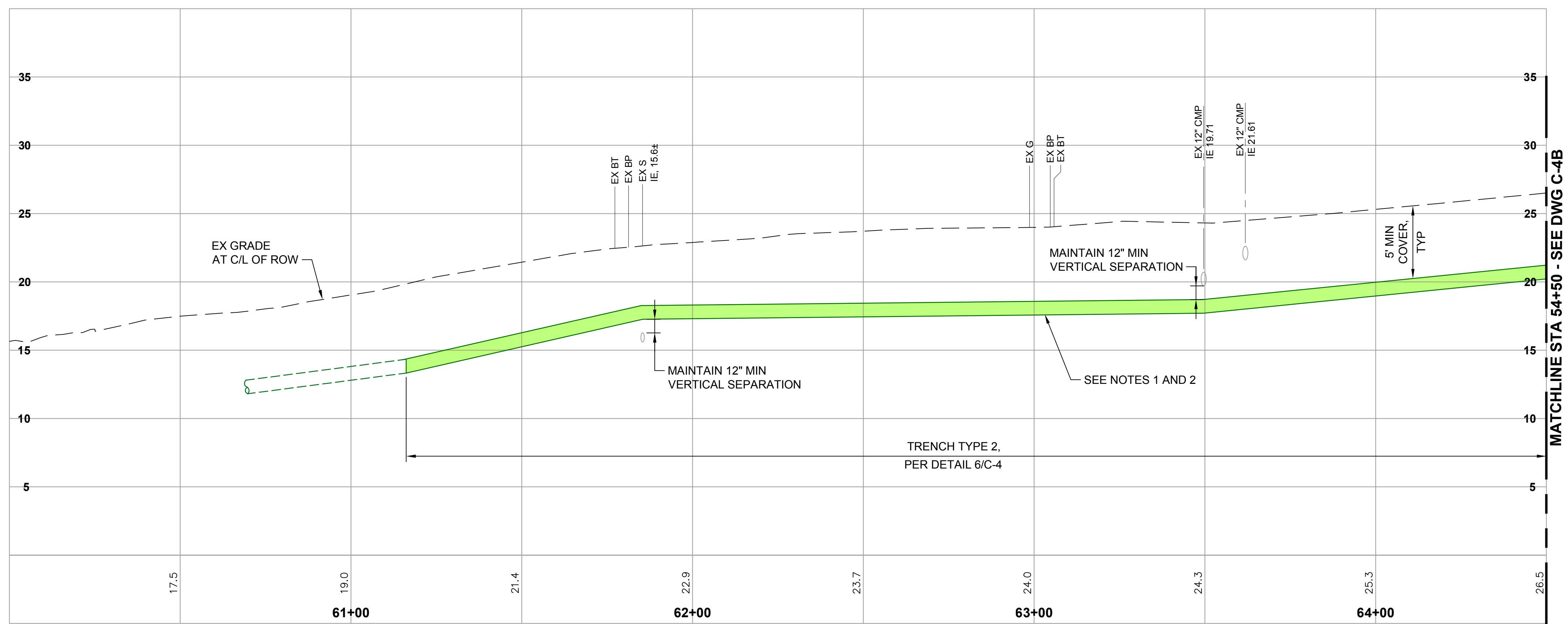

**Call 48 Hours Before You Dig**  
1-800-424-5555  
UNDERGROUND SERVICE

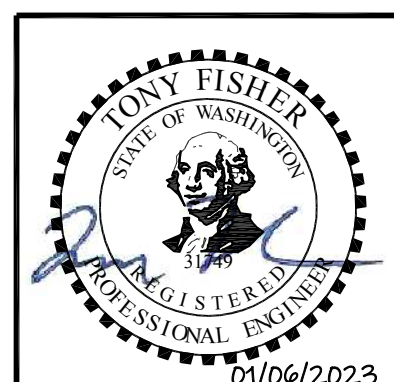

No.	Revision	Date	By	App'd
	ISSUED FOR BID	01-2023	TF	RAD

<p><b>BHC Consultants, LLC</b> 1601 Fifth Avenue, Suite 500 Seattle, Washington 98101 206.505.3400 206.505.3406 (fax) www.bhcconsultants.com</p>	Designed: T. Fisher, P.E.	Scale: Horiz: 1" = 20'-0" Vert: 1" = 5'-0"  One Inch at Full Scale If Not One Inch Scale Accordingly	 <b>Kitsap County Public Works</b> 614 Division Street, MS 26 Port Orchard, WA 98366	<b>SILVERDALE CONVEYANCE SYSTEM AND PUMP STATION 4 UPGRADES</b> <b>SCHEDULE B</b> <b>McCONNEL AVE SE</b> <b>PLAN AND PROFILE</b> <b>STA 60+00 TO STA 64+50</b>
	Drawn: A. Cariaso			
	Drawing: <b>C-3B</b> Sheet: <b>30</b> of <b>117</b> File: P21-10530_C-1B-4B Date: January 2023			
	Copyright © 2023 BHC CONSULTANTS, LLC. ALL RIGHTS RESERVED.			

Path: S:\Cad\Kitsap County\21-10530 Silverdale Conveyance-PS 4 Upgrd\Design\Drawings\21-10530\_C-1B-4B\_Plan.dwg, Plot date: Jan 06, 2023 02:08:52pm, CAD User: J.Lira, Xref Filename: 21-10530-SCU\_Ext Topo Old Town\1\21-10530-SCU\_Fisher\1\21-10530-SCU\_Ext Align-Prop SS\1\21-10530-SCU\_Ext Topo\1\21-10530-SCU\_Ext Topo\1\Palmetier\

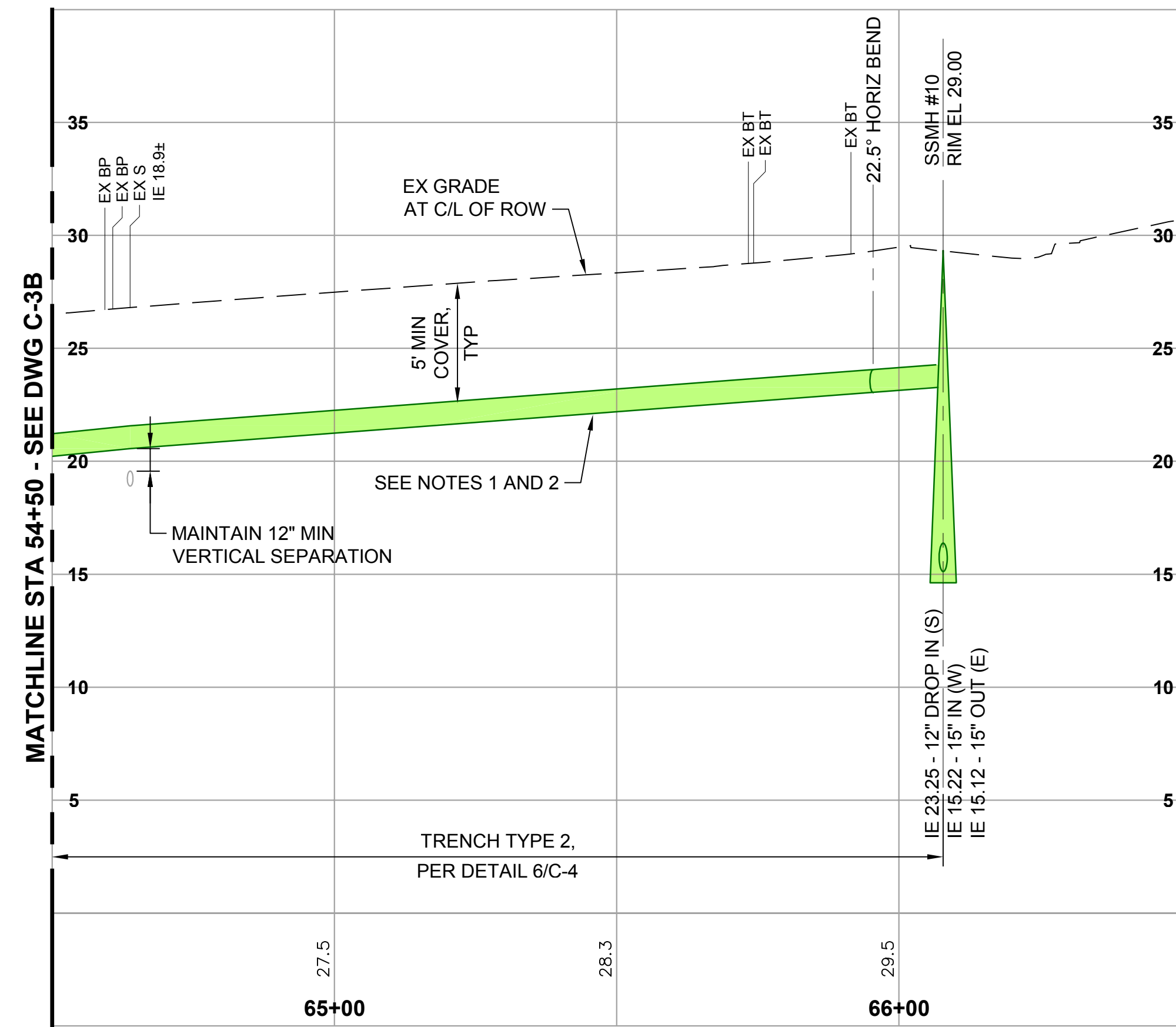
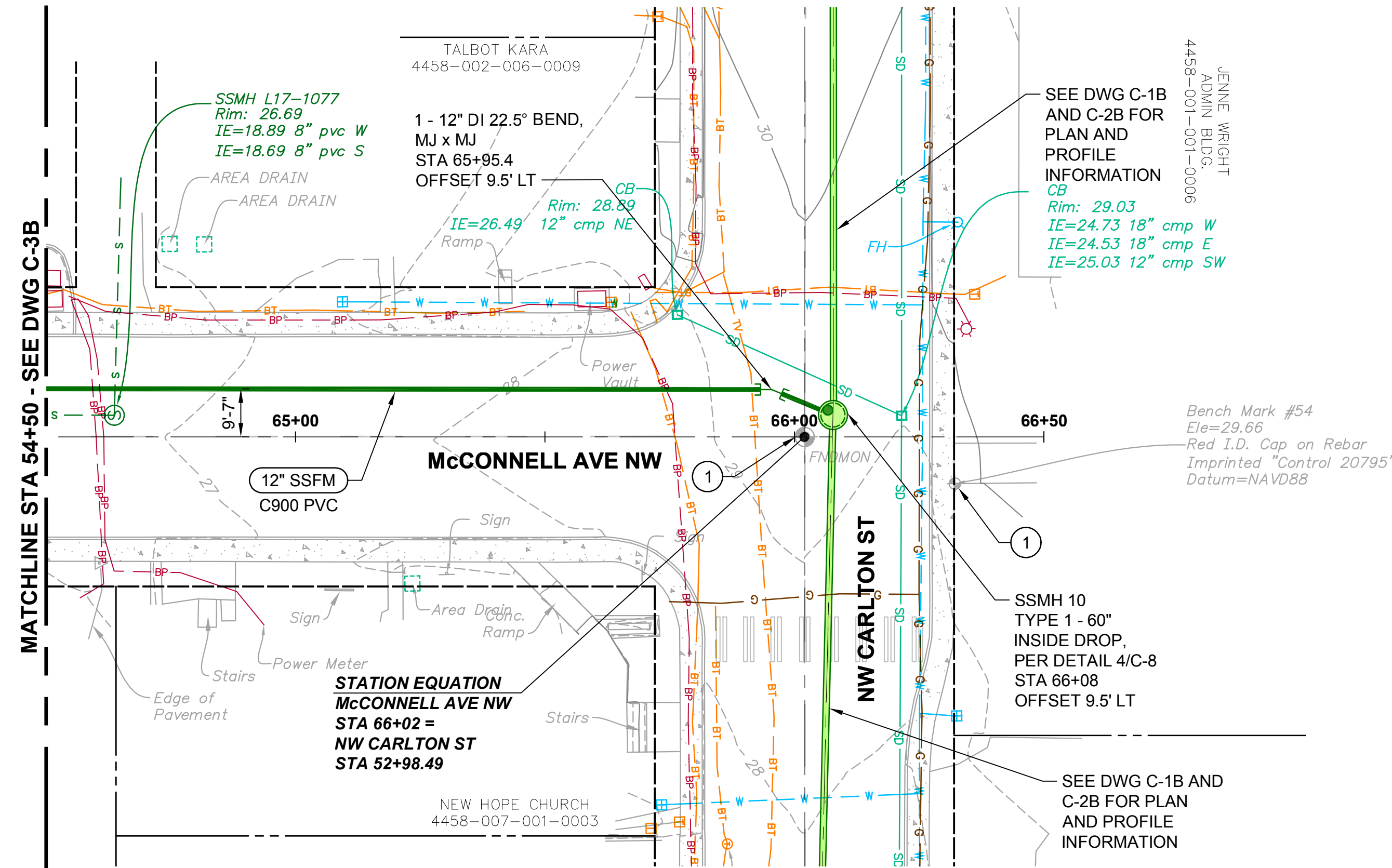
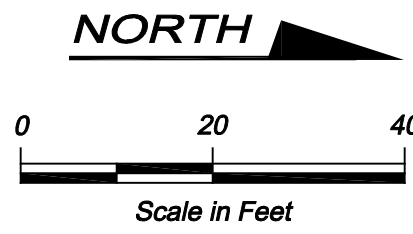

**NOTES:**

1. MAINTAIN POSITIVE SLOPE ON THE FORCE MAIN AND AVOID HIGH AND LOW POINTS UNLESS SPECIFICALLY CALL OUT.
2. DEFLECT PIPE VERTICALLY PER MANUFACTURER'S RECOMMENDATIONS TO SMOOTHLY TRANSITION GRADE WHILE ADHERING TO COVER REQUIREMENTS.
3. FOR ALL SURFACES SUBJECT TO VEHICULAR TRAFFIC, RESTORE DISTURBED AREAS WITH 1" MIN TEMPORARY HMA PATCH AND TEMP STRIPING BY THE END OF EACH WORK DAY. MAINTAIN TEMP HMA PATCH AND TEMP STRIPING UNTIL IT IS REPLACED WITH THE PERMANENT RESTORATION.
4. POT HOLE EXISTING UTILITIES AS NECESSARY TO VERIFY INVERTS PRIOR TO CONSTRUCTING FORCE MAIN TO ALLOW ADJUSTMENTS TO FORCE MAIN DEPTH TO MAINTAIN AT LEAST 12 INCHES OF VERTICAL SEPARATION.
5. ALL MJ FITTINGS SHALL BE RESTRAINED AND HAVE THRUST BLOCKS.

**CONSTRUCTION NOTES:**

1. PROTECT BENCHMARK/SURVEY MONUMENT. IF THE BENCHMARK/ MONUMENT MUST BE DISTURBED, WORK SHALL COMPLY WITH SECTION 1-05.4 OF THE SPECIAL PROVISIONS AND THE WASHINGTON STATE DNR PERMIT TO DESTROY OR REMOVE A SURVEY MONUMENT.

**Call 48 Hours Before You Dig**

**1-800-424-5555**  
UNDERGROUND SERVICE

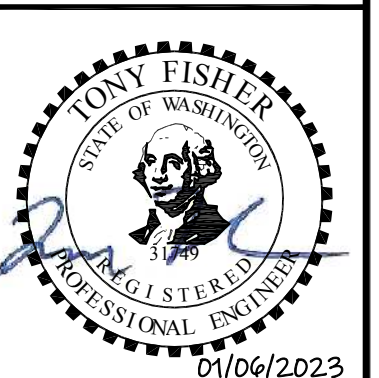

**BHC Consultants, LLC**  
 1601 Fifth Avenue, Suite 500  
 Seattle, Washington 98101  
 206.505.3400  
 206.505.3406 (fax)  
 www.bhcconsultants.com

Designed: T. Fisher, P.E.  
 Drawn: A. Carioso  
 Checked: R. Dorn, P.E.

Scale:  
 Horiz: 1" = 20'-0"  
 Vert: 1" = 5'-0"  
 One Inch at Full Scale  
 If Not One Inch Scale Accordingly



**Kitsap County Public Works**  
 614 Division Street, MS 26  
 Port Orchard, WA 98366

**SILVERDALE CONVEYANCE SYSTEM AND PUMP STATION 4 UPGRADES**  
**SCHEDULE B**  
**McCONNELL AVE NW**  
**PLAN AND PROFILE**  
**STA 64+50 TO STA 66+50**

Drawing: **C-4B**  
 Sheet: **31** of **117**  
 File: P21-10530\_C-1B-4B  
 Date: January 2023

Path: S:\Cadd\Kitsap County\21-10530 Silverdale Conveyance-PS 4 Uprgt\Design\Drawings\21-10530\_P-1B-2B\_Plot.dwg, Jan 06, 2023 01:52:27pm CAD User: abradley.  
 Xref Filename: \\X21-10530-SCU\_Ext\Topo\Old Town\1\X21-10530\_TB\Fisher\1\X21-10530-SCU\_Prop SS [Dgn] | Palmalter |

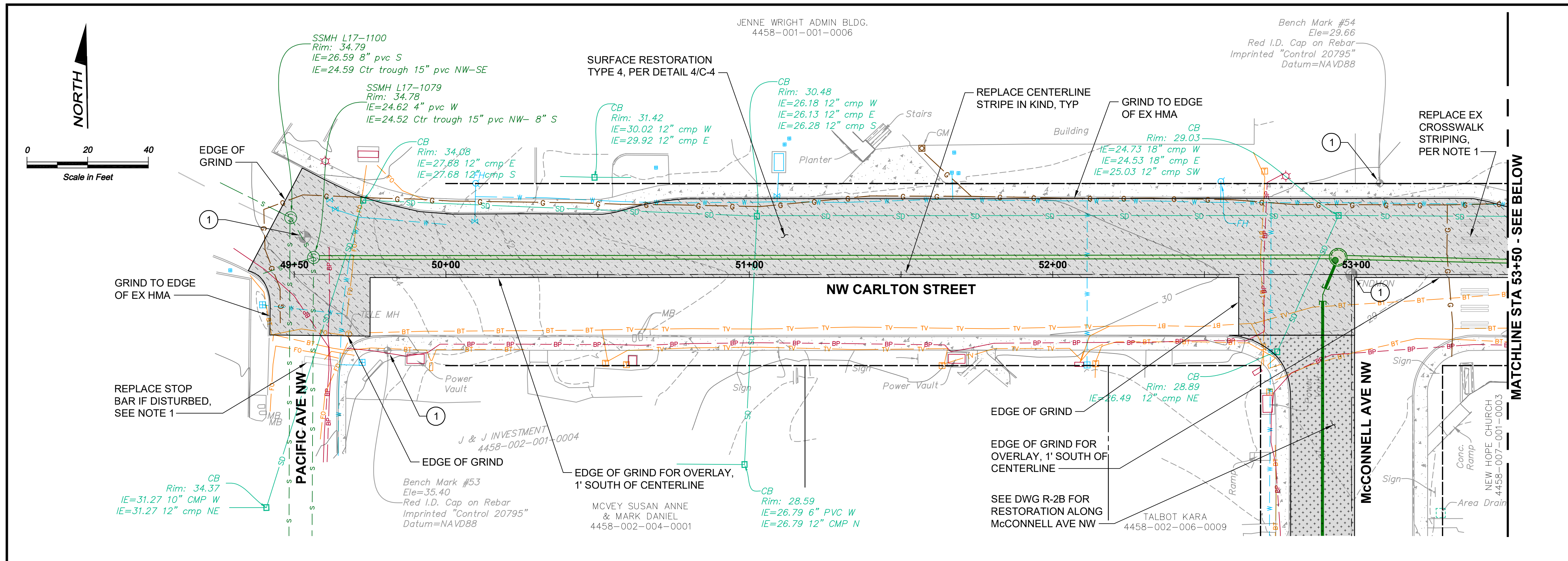

**NOTES:**

- REFERENCE STREET CENTERLINE STRIPING, STOP BARS, CROSS WALK STRIPING, AND OTHER SURFACE STREET MARKING PRIOR TO DISTURBING EXISTING AC PAVEMENT. RESTORE ALL MARKINGS IN KIND TO ORIGINAL LOCATIONS AFTER COMPLETION OF FINAL RESTORATION.

**CONSTRUCTION NOTES:**

- PROTECT BENCHMARK/SURVEY MONUMENT. IF THE BENCHMARK/ MONUMENT MUST BE DISTURBED, WORK SHALL COMPLY WITH SECTION 1-05.4 OF THE SPECIAL PROVISIONS AND THE WASHINGTON STATE DNR PERMIT TO DESTROY OR REMOVE A SURVEY MONUMENT.

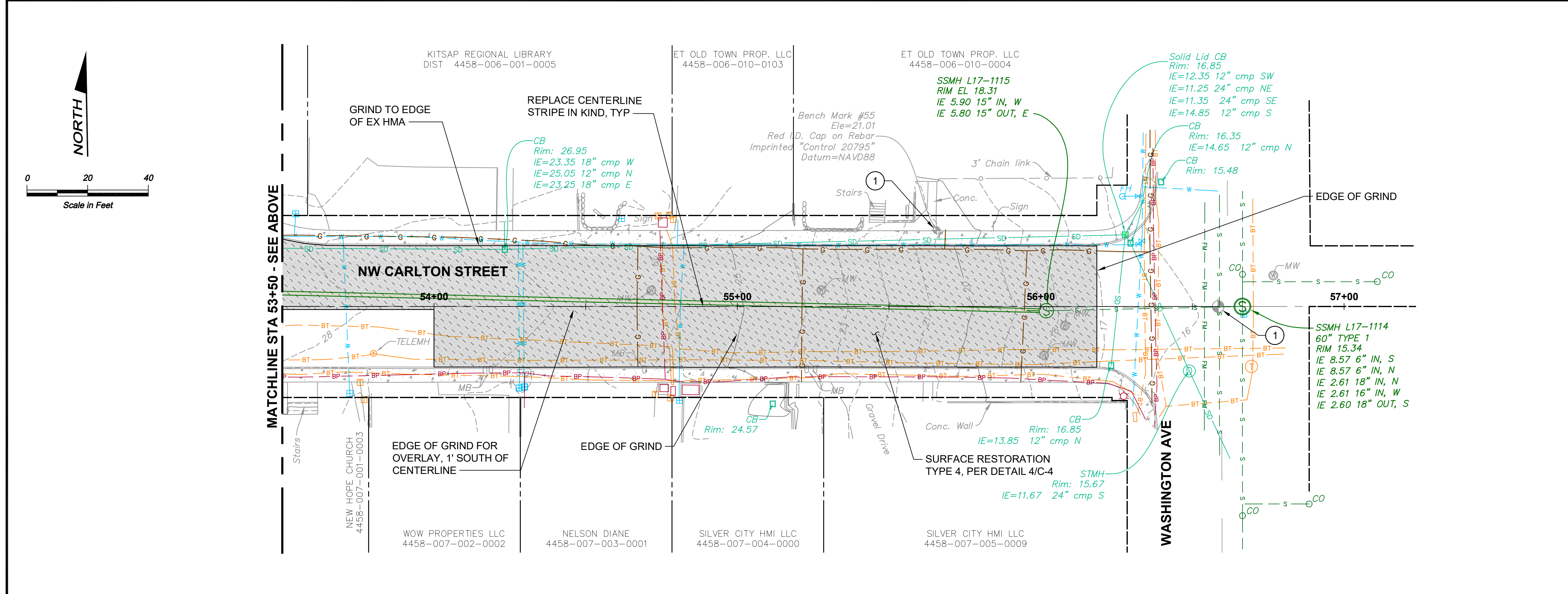

**Call 48 Hours Before You Dig**  
 1-800-424-5555  
 UNDERGROUND SERVICE

**TONY FISHER**  
 STATE OF WASHINGTON  
 REGISTERED PROFESSIONAL ENGINEER  
 01/06/2023

No.	Revision	Date	By	App'd
	ISSUED FOR BID	01-2023	TF	RAD

**bhc CONSULTANTS**  
 BHC Consultants, LLC  
 1601 Fifth Avenue, Suite 500  
 Seattle, Washington 98101  
 206.505.3400  
 206.505.3406 (fax)  
 www.bhcconsultants.com

Designed: T. Fisher, P.E.  
 Drawn: A. Cariaso  
 Checked: R. Dorn, P.E.

Scale:  
 1" = 20'-0"  
 One Inch at Full Scale  
 If Not One Inch Scale Accordingly

**Kitsap County Public Works**  
 614 Division Street, MS 26  
 Port Orchard, WA 98366

**SILVERDALE CONVEYANCE SYSTEM AND PUMP STATION 4 UPGRADES SCHEDULE B**  
**NW CARLTON STREET RESTORATION PLAN STA 49+50 TO STA 56+50**

Drawing: **R-1B**  
 Sheet: **32** of **117**  
 File: P21-10530\_R-1B-2B  
 Date: January 2023



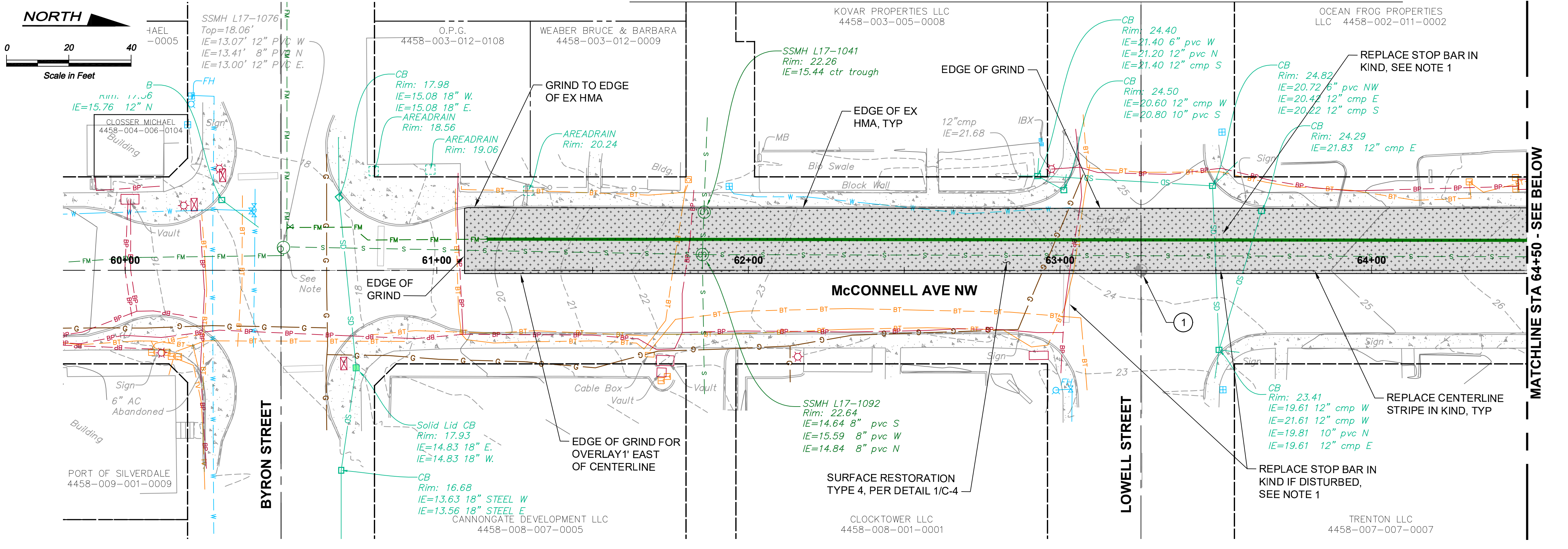

**NOTES:**

- REFERENCE STREET CENTERLINE STRIPING, STOP BARS, CROSS WALK STRIPING, AND OTHER SURFACE STREET MARKING PRIOR TO DISTURBING EXISTING AC PAVEMENT. RESTORE ALL MARKINGS IN KIND TO ORIGINAL LOCATIONS AFTER COMPLETION OF FINAL RESTORATION.

**CONSTRUCTION NOTES:**

- PROTECT BENCHMARK/SURVEY MONUMENT. IF THE BENCHMARK/ MONUMENT MUST BE DISTURBED, WORK SHALL COMPLY WITH SECTION 1-05.4 OF THE SPECIAL PROVISIONS AND THE WASHINGTON STATE DNR PERMIT TO DESTROY OR REMOVE A SURVEY MONUMENT.

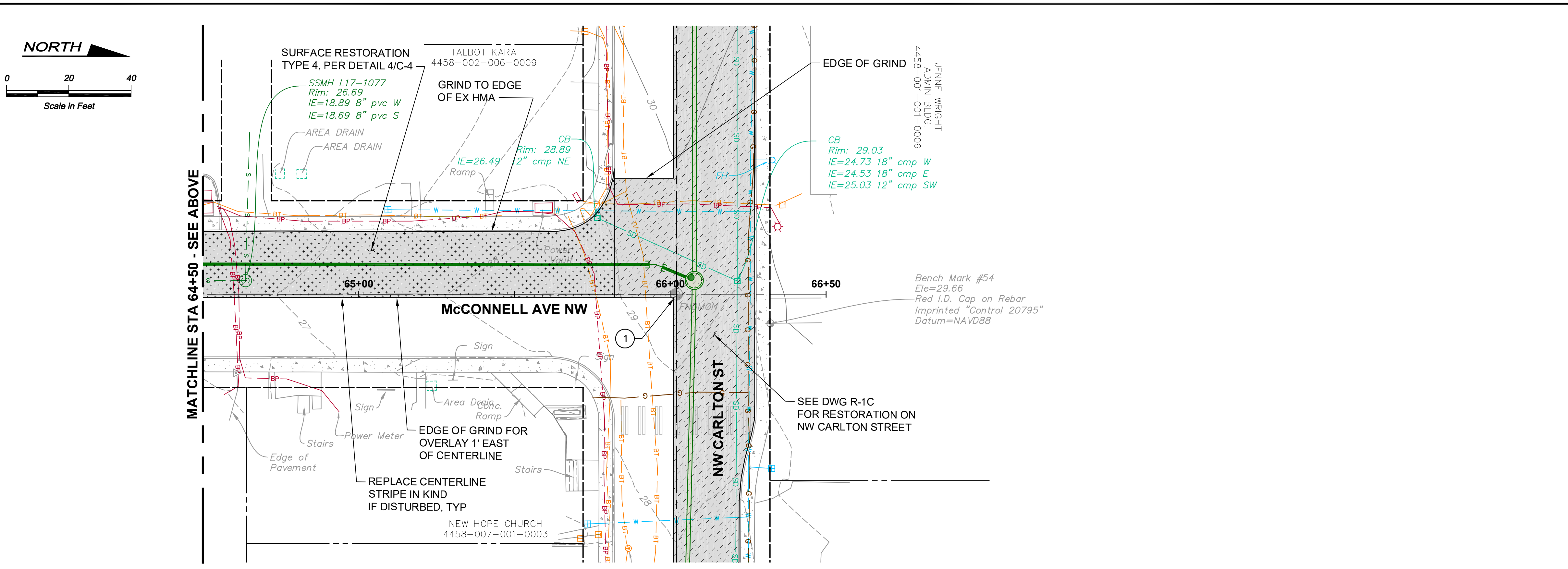

**Call 48 Hours Before You Dig**

**1-800-424-5555**  
UNDERGROUND SERVICE

Path: S:\Cadd\Kitsap County\21-10530 Silverdale Conveyance-PS 4 Uprtg\Design\Drawings\21-10530\_R-1B-2B\_Plot.dwg, Jan 06, 2023 01:53:33pm CAD User: abradley.  
 Xref Filename: \\X21-10530-SCU\_Ext\Topo\Old Town\X21-10530\_TB\Fisher\X21-10530-SCU\_Prop SS [Detail] [Palmtail]

No.	Revision	Date	By	App'd

**bhc CONSULTANTS**

**BHC Consultants, LLC**  
1601 Fifth Avenue, Suite 500  
Seattle, Washington 98101  
206.505.3400  
206.505.3406 (fax)  
www.bhcconsultants.com

Designed: T. Fisher, P.E.	Scale: 1" = 20'-0"
Drawn: A. Cariaso	One Inch at Full Scale If Not One Inch Scale Accordingly
Checked: R. Dorn, P.E.	

**Kitsap County Public Works**  
614 Division Street, MS 26  
Port Orchard, WA 98366

**SILVERDALE CONVEYANCE SYSTEM AND PUMP STATION 4 UPGRADES**  
SCHEDULE B  
**McCONNELL AVE NW RESTORATION PLAN**  
STA 60+00 TO STA 66+00

Drawing: <b>R-2B</b>
Sheet: <b>33</b> of <b>117</b>
File: P21-10530_R-1C-2C
Date: January 2023

# DETOUR ROUTE FOR NW CARLTON ST

NOT TO SCALE

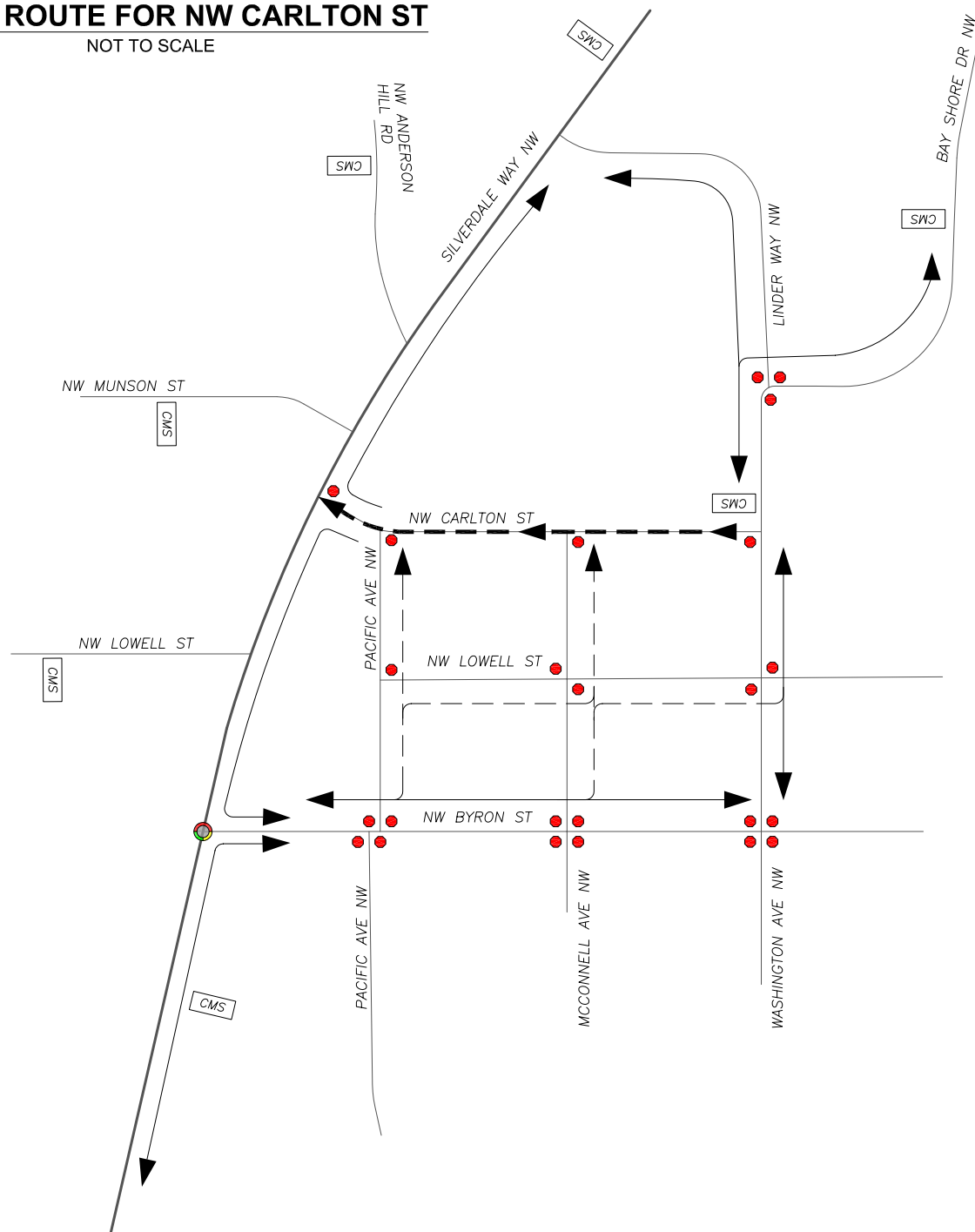

## TRAFFIC CONTROL NOTES – NW CARLTON ST ONLY

1. CONTRACTOR SHALL BE RESPONSIBLE FOR MEANS AND METHODS OF CONSTRUCTION AND SCHEDULING, INCLUDING ALL TRAFFIC CONTROL DURING CONSTRUCTION, AS IDENTIFIED IN THE WSDOT STANDARD SPECIFICATIONS AND AS AMENDED IN THE CONTRACT.
2. CONSTRUCTION ACTIVITY ON ARTERIALS AND LOCAL STREETS IN THE PUBLIC RIGHT OF WAY SHALL BE LIMITED TO WEEKDAYS, AND WORK HOURS SHALL BE ANY CONSECUTIVE 8-HOUR PERIOD BETWEEN 7 AM TO 6 PM. NW CARLTON ST SHALL BE OPENED WITH ONE TRAVEL LANE, FOR ONE-WAY WESTBOUND TRAFFIC ONLY, DURING THE CONSECUTIVE 8-HOUR PERIOD.
3. THE CONTRACTOR SHALL PROVIDE CHANGEABLE MESSAGE SIGNS (CMS) TO INFORM THE TRAVELING PUBLIC OF UPCOMING CLOSURE AND DETOURS. CMS'S SHALL BE PLACED ALONG THE CONSTRUCTION ROUTE AND DETOUR ROUTE AT LEAST TWO WEEKS IN ADVANCE OF CLOSURE. CMS'S SHALL BE LOCATED, AT A MINIMUM, AT THE LOCATIONS SHOWN ON THIS SHEET.
4. THE CONTRACTOR SHALL PROVIDE FOR PEDESTRIAN ACCESS AROUND OR THROUGH CONSTRUCTION WORK AT ALL TIMES.
5. THE CONTRACTOR SHALL POST MOTORCYCLE SUPPLEMENTAL WARNING SIGNS FOR WORK ZONES WITH STEEL PLATES OR UNEVEN ROADWAY SURFACE.
6. THE CONTRACTOR SHALL COORDINATE WITH EMERGENCY SERVICE PROVIDER, CENTRAL KITSAP SCHOOL DISTRICT, KITSAP TRANSIT, PARATRANSIT SERVICES, AND PORTAL SERVICE AT LEAST TWO WEEKS PRIOR TO ANY CHANGE TO TRAFFIC CONTROL.
7. DURING LANE CLOSURE THE CONTRACTOR SHALL MAINTAIN LOCAL ACCESS TO ALL PROPERTIES IN THE CLOSED AREA AND MAINTAIN ONE MINIMUM 10' TRAVEL LANE THROUGH WORK ZONE.
8. CONSTRUCTION WORK AREA WILL INCLUDE THE WESTBOUND TRAVEL LANE FOR NW CARLTON ST FROM PACIFIC AVE NW TO WASHINGTON AVE NW.

TRAFFIC CONTROL PLAN LEGEND	
DESCRIPTION	
	ONE WAY ROUTE
	SIGNED DETOUR
	STOP SIGN
	TRAFFIC SIGNAL
	CHANGEABLE MESSAGE SIGN
	ALTERNATIVE ROUTE



**Call 48 Hours Before You Dig**  
 1-800-424-5555  
 UNDERGROUND SERVICE

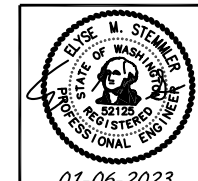

07-06-2023

No.	Revision	Date	By	App'd

**bhc CONSULTANTS**  
 BHC Consultants, LLC  
 1601 Fifth Avenue, Suite 500  
 Seattle, Washington 98101  
 206.505.3400  
 206.505.3406 (fax)  
 www.bhcconsultants.com

**TENW**  
 Transportation Engineering NorthWest  
 Transportation Planning | Design | Traffic Impact & Operations  
 11400 SE 8th Street, Suite 200, Bellevue, WA 98004 | Office (425) 889-4747  
 Project Contact: Trevin Roletto, P.E.  
 Phone: 425-250-0583

Designed: TDR  
 Drawn: TDR  
 Checked: EMS

Scale:  
 N.T.S.  
 One Inch At Full Scale  
 If Not One Inch Scale Accordingly

**Kitsap County Public Works**  
 614 Division Street, MS 26  
 Port Orchard, WA 98366

**SILVERDALE CONVEYANCE SYSTEM AND PUMP STATION 4 UPGRADES**  
 SCHEDULE B  
 TRAFFIC CONTROL PLANS  
 NW CARLTON ST

Drawing: TC-1B  
 Sheet: 34 of 117  
 File: KP-MASTER TCP  
 Date: JANUARY 2023

# DETOUR ROUTE FOR MCCONNELL AVE NW

NOT TO SCALE

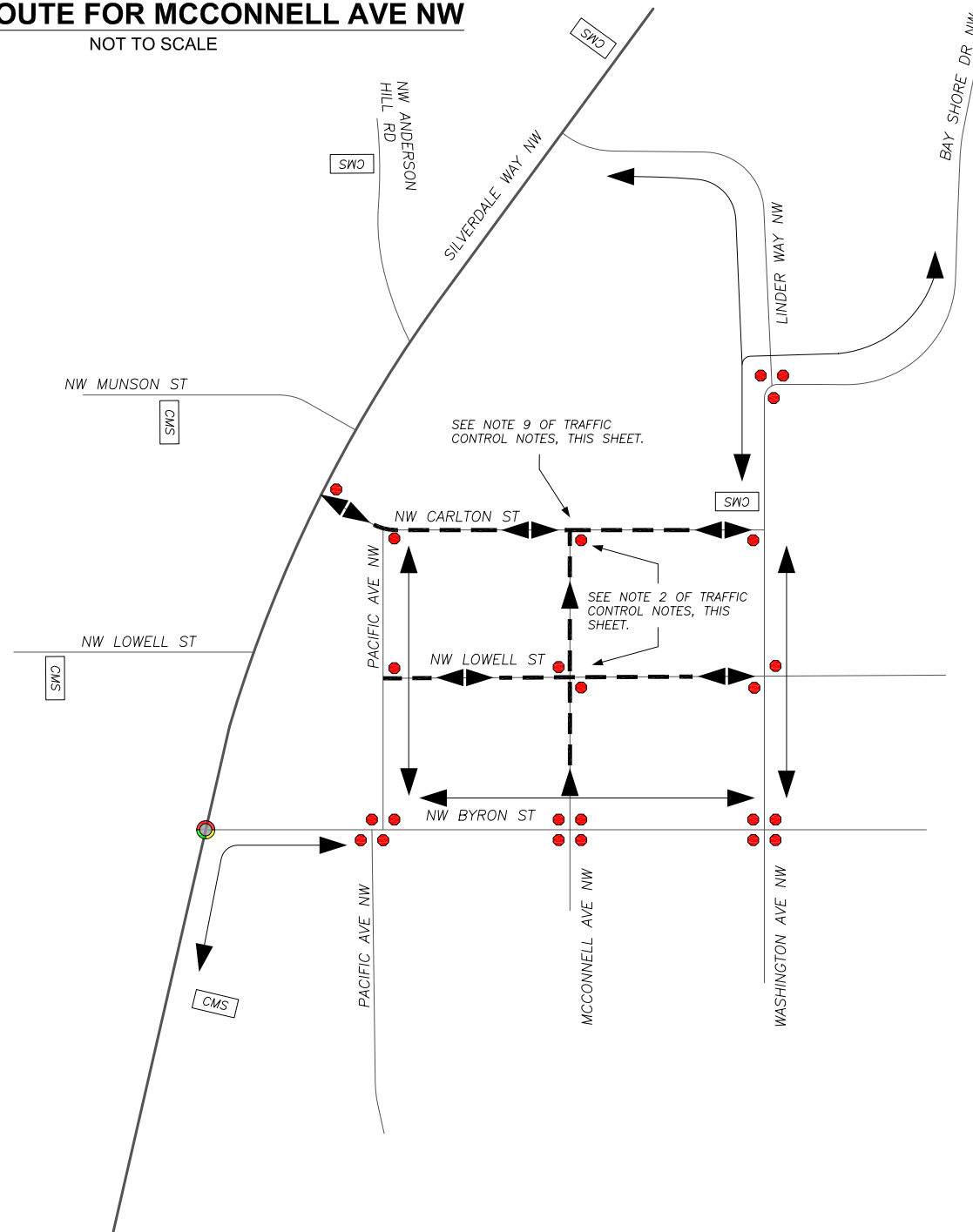

## TRAFFIC CONTROL NOTES – MCCONNELL AVE NW ONLY

1. CONTRACTOR SHALL BE RESPONSIBLE FOR MEANS AND METHODS OF CONSTRUCTION AND SCHEDULING, INCLUDING ALL TRAFFIC CONTROL DURING CONSTRUCTION, AS IDENTIFIED IN THE WSDOT STANDARD SPECIFICATIONS AND AS AMENDED IN THE CONTRACT.
2. CONSTRUCTION ACTIVITY ON ARTERIALS AND LOCAL STREETS IN THE PUBLIC RIGHT OF WAY SHALL BE LIMITED TO WEEKDAYS, AND WORK HOURS SHALL BE ANY CONSECUTIVE 8-HOUR PERIOD BETWEEN 7 AM TO 6 PM. NW LOWELL ST AND NW CARLTON ST SHALL BE OPENED FOR TWO-WAY TRAFFIC (WESTBOUND AND EASTBOUND) DURING THE CONSECUTIVE 8-HOUR PERIOD. THE INTERSECTIONS OF NW CARLTON ST / MCCONNELL AVE NW AND NW LOWELL ST / MCCONNELL AVE NW SHALL BE ONE-WAY TRAFFIC, WITH FLAGGER CONTROL, TO ALLOW TWO-WAY ACCESS DURING CONSTRUCTION WITHIN THE INTERSECTION. MCCONNELL AVE NW SHALL BE OPENED FOR ONE-WAY NORTHBOUND TRAFFIC ONLY, DURING THE CONSECUTIVE 8-HOUR PERIOD.
3. THE CONTRACTOR SHALL PROVIDE CHANGEABLE MESSAGE SIGNS (CMS) TO INFORM THE TRAVELING PUBLIC OF UPCOMING CLOSURE AND DETOURS. CMS'S SHALL BE PLACED ALONG THE CONSTRUCTION ROUTE AND DETOUR ROUTE AT LEAST TWO WEEKS IN ADVANCE OF CLOSURE. CMS'S SHALL BE LOCATED, AT A MINIMUM, AT THE LOCATIONS SHOWN ON THIS SHEET.
4. THE CONTRACTOR SHALL PROVIDE FOR PEDESTRIAN ACCESS AROUND OR THROUGH CONSTRUCTION WORK AT ALL TIMES.
5. THE CONTRACTOR SHALL POST MOTORCYCLE SUPPLEMENTAL WARNING SIGNS FOR WORK ZONES WITH STEEL PLATES OR UNEVEN ROADWAY SURFACE.
6. THE CONTRACTOR SHALL COORDINATE WITH EMERGENCY SERVICE PROVIDER, CENTRAL KITSAP SCHOOL DISTRICT, KITSAP TRANSIT, PARATRANSIT SERVICES, AND PORTAL SERVICE AT LEAST TWO WEEKS PRIOR TO ANY CHANGE TO TRAFFIC CONTROL.
7. DURING LANE CLOSURE THE CONTRACTOR SHALL MAINTAIN LOCAL ACCESS TO ALL PROPERTIES IN THE CLOSED AREA AND MAINTAIN ONE MINIMUM 10' TRAVEL LANE THROUGH WORK ZONE.
8. CONSTRUCTION WORK AREA WILL INCLUDE THE SOUTHBOUND TRAVEL LANE FOR MCCONNELL AVE NW FROM NW CARLTON ST TO NW BYRON ST.
9. CONTRACTOR SHALL CLOSE THE NORTHBOUND LEFT TURN MOVEMENT AT INTERSECTION OF NW CARLTON ST / MCCONNELL AVE NW FOR CONSTRUCTION WITHIN THE INTERSECTION.
  - 9.1. INTERSECTION WORK SHALL BE COMPLETED BEFORE THE START OF CONSTRUCTION ALONG MCCONNELL AVE NW OR AFTER THE CONSTRUCTION ALONG MCCONNELL AVE NW HAS BEEN COMPLETED UP TO THE INTERSECTION. FLAGGER CONTROL SHALL BE USED TO MAINTAIN TWO-WAY TRAFFIC ALONG NW CARLTON ST DURING WORK AT THE INTERSECTION OF NW CARLTON ST AND MCCONNELL AVE NW.
  - 9.2. WHEN NORTHBOUND LEFT TURN IS CLOSED THROUGH THE INTERSECTION, DETOUR NORTHBOUND TRAFFIC ALONG MCCONNELL AVE NW TO WESTBOUND ON NW CARLTON ST TO WASHINGTON AVE NW.

TRAFFIC CONTROL PLAN LEGEND	
DESCRIPTION	
	ONE WAY ROUTE
	TWO WAY ROUTE
	SIGNED DETOUR
	STOP SIGN
	TRAFFIC SIGNAL
	CHANGEABLE MESSAGE SIGN



**Call 48 Hours Before You Dig**

**1-800-424-5555**  
UNDERGROUND SERVICE



07-06-2023

No.	Revision	Date	By	App'd

**bhc CONSULTANTS**  
BHC Consultants, LLC  
1601 Fifth Avenue, Suite 500  
Seattle, Washington 98101  
206.505.3400  
206.505.3406 (fax)  
www.bhcconsultants.com

**TENW**  
Transportation Engineering NorthWest  
Transportation Planning | Design | Traffic Impact & Operations  
11400 SE 8th Street, Suite 200, Bellevue, WA 98004 | Office (425) 889-4747  
Project Contact: Trevin Roletto, P.E.  
Phone: 425-250-0583

Designed: TDR  
Drawn: TDR  
Checked: EMS  
Scale: N.T.S.  
One Inch At Full Scale  
If Not One Inch Scale Accordingly

**Kitsap County Public Works**  
614 Division Street, MS 26  
Port Orchard, WA 98366

**SILVERDALE CONVEYANCE SYSTEM AND PUMP STATION 4 UPGRADES**  
SCHEDULE B  
TRAFFIC CONTROL PLANS  
MCCONNELL AVE NW

Drawing: TC-2B  
Sheet: 35 of 117  
File: KP-MASTER TCP  
Date: JANUARY 2023

BUCKLIN HILL ROAD  
Vol. 9 Pg. 22

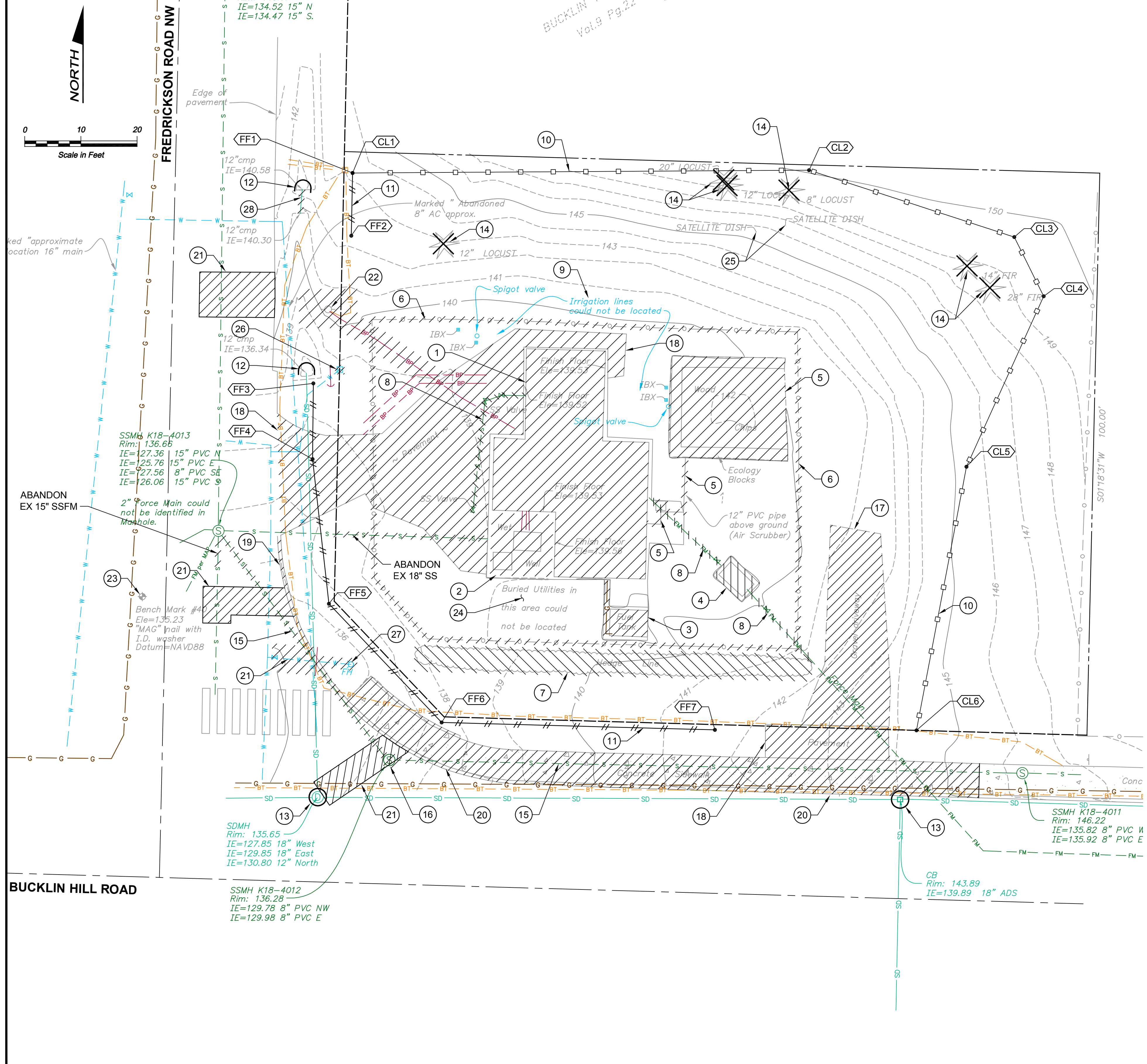

**CONSTRUCTION NOTES:**

- 1 DEMOLISH AND REMOVE THE EXISTING ABOVE GRADE BUILDING AS SHOWN ON DRAWINGS D-2C AND D-3C. PROTECT BELOW GROUND STRUCTURES NOT DESIGNATED FOR REMOVAL.
- 2 REMOVE AND DISPOSE OF TOP SLAB OF EXISTING WET WELL PER DRAWING D-2C AND STRUCTURAL DRAWINGS.
- 3 REMOVE AND DISPOSE OF EXISTING DIESEL TANK AND FOUNDATION AND ASSOCIATED FUEL PIPING.
- 4 REMOVE AND DISPOSE OF EXISTING VAULT.
- 5 REMOVE AND DISPOSE OF EXISTING AIR SCRUBBER, BIOFILTRATION BED, ECOLOGY BLOCKS, WOOD CHIPS AND ALL ASSOCIATED PIPING AND APPURTENANCES.
- 6 REMOVE AND DISPOSE OF EXISTING FENCE AND GATE.
- 7 REMOVE AND DISPOSE OF EXISTING HEDGE.
- 8 REMOVE EXISTING FORCE MAIN AS SHOWN TO ACCOMMODATE NEW FACILITIES. PROVIDE TEMPORARY BYPASS PIPING AS NEEDED. FOLLOWING COMMISSIONING OF NEW LIFT STATION, REMOVE ALL TEMPORARY FACILITIES.
- 9 LOCATE AND REMOVE EXISTING IRRIGATION LINES.
- 10 INSTALL CONSTRUCTION LIMIT FENCING, PER DETAIL 2/C-1.
- 11 INSTALL/MAINTAIN FILTER FABRIC FENCE PER DETAIL 1/C-1 AROUND THE PERIMETER.
- 12 INSTALL SILT DIKE PER DETAIL 5/C-1.
- 13 INSTALL CATCH BASIN INSERT PER DETAIL 3/C-1.
- 14 REMOVE AND DISPOSE OF EXISTING TREE AND STUMP.
- 15 ABANDON EXISTING SS PER THE SPECIAL PROVISIONS.
- 16 ABANDON EXISTING SSMH BY REMOVING AND DISPOSING OF THE TOP 4 FEET OF THE SSMH AND FILLING THE REMAINDER OF THE SSMH WITH SAND OR CDF.
- 17 REMOVE AND DISPOSE OF EXISTING GRAVEL DRIVEWAY.
- 18 REMOVE AND DISPOSE OF EXISTING ASPHALT DRIVEWAY.
- 19 SAWCUT, REMOVE AND DISPOSE OF EXISTING CONCRETE CURB.
- 20 SAWCUT, REMOVE AND DISPOSE OF EXISTING CONCRETE SIDEWALK AND CURB, TO THE CLOSEST CONSTRUCTION JOINT.
- 21 SAWCUT, REMOVE AND DISPOSE OF EXISTING ASPHALT PAVEMENT.
- 22 REMOVE EXISTING UTILITY POLE. RELOCATE UTILITY POLE AS SHOWN ON E-2C. PROVIDE NEW PRIMARY AND SECONDARY POWER CONNECTIONS.
- 23 PROTECT BENCHMARK/SURVEY MONUMENT. IF THE BENCHMARK/ MONUMENT MUST BE DISTURBED, WORK SHALL COMPLY WITH SECTION 1-05.4 OF THE SPECIAL PROVISIONS AND THE WASHINGTON STATE DNR PERMIT TO DESTROY OR REMOVE A SURVEY MONUMENT.
- 24 LOCATE, REMOVE AND DISPOSE OF BURIED UTILITIES IN THIS AREA.
- 25 REMOVE AND DISPOSE OF EXISTING SATELLITE DISHES.
- 26 REMOVE/RELOCATE EXISTING WATER METER AND SERVICE.
- 27 RELOCATE EXISTING FIRE HYDRANT PER DWG C-2-C.
- 28 REMOVE EXISTING 12" CMP.

**NOTES:**

1. SEE DRAWING G-4 AND SPECIAL PROVISIONS FOR SUGGESTED CONSTRUCTION SEQUENCING AND BYPASS CONSTRUCTIONS/REQUIREMENTS.
2. PROTECT ALL EXISTING UTILITIES AND STRUCTURES UNLESS SPECIFICALLY INDICATED TO BE REMOVED OR ABANDONED.
3. MAINTAIN ACCESS TO EXISTING LIFT STATION AND SITE FACILITIES FOR COUNTY STAFF AND SERVICE VEHICLES AT ALL TIMES.
4. REMOVE EXISTING ASPHALT, GRAVEL, VEGETATION, AND GROUND AS NECESSARY TO ACCOMMODATE UPGRADES. SEE RESTORATION DRAWINGS FOR FINAL SITE RESTORATION REQUIREMENTS.
5. SEE DRAWING G-4 FOR ADDITIONAL EROSION AND SEDIMENT CONTROL NOTES.
6. ADJUST/REMOVE/REPLACE TESC MEASURES AS NECESSARY TO CONSTRUCT IMPROVEMENTS.
7. LEGALLY DISPOSE OF ALL DEMOLITION DEBRIS.

COORDINATE CONTROL			
PT #	NORTHING	EASTING	DESCRIPTION
CL1	242828.22	1186586.43	CLEARING LIMITS
CL2	242828.72	1186667.66	CLEARING LIMITS
CL3	242816.83	1186704.18	CLEARING LIMITS
CL4	242806.30	1186709.41	CLEARING LIMITS
CL5	242775.97	1186695.67	CLEARING LIMITS
CL6	242729.08	1186686.77	CLEARING LIMITS
FF1	242828.22	1186586.43	FILTER FABRIC FENCE
FF2	242817.06	1186586.20	FILTER FABRIC FENCE
FF3	242790.80	1186579.45	FILTER FABRIC FENCE
FF4	242777.33	1186579.31	FILTER FABRIC FENCE
FF5	242751.60	1186582.22	FILTER FABRIC FENCE
FF6	242730.49	1186602.28	FILTER FABRIC FENCE
FF7	242729.17	1186650.90	FILTER FABRIC FENCE

**COORDINATE CONTROL NOTES:**

1. SEE DWG C-1C AND C-7C FOR ADDITIONAL COORDINATE POINTS.
2. ADJUST LOCATION OF FILTER FENCE AS NEEDED TO KEEP FENCE DOWNSTREAM OF ALL DISTURBED SOILS.

Path: S:\Cadd\Kitsap County\21-10530 Silverdale Conveyance-PS 4 Upgr\Design\Drawings\21-10530-PS4\_1B\21-10530-PS4\_1B.dwg  
 Xref Filename: I:\Fisher\21-10530-PS4\_1B\21-10530-PS4\_1B.dwg  
 Date: Jan 06, 2023 06:47:18pm  
 CAD User: sfolice

Call 48 Hours Before You Dig  
1-800-424-5555  
UNDERGROUND SERVICE

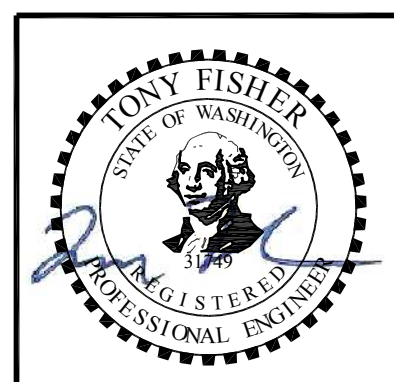

	<b>BHC Consultants, LLC</b> 1601 Fifth Avenue, Suite 500 Seattle, Washington 98101 206.505.3400 206.505.3406 (fax) www.bhcconsultants.com	Designed: T. Fisher, P.E. Drawn: P. Simon Checked: R. Dorn, P.E.	Scale: 1" = 10'-0" One Inch at Full Scale If Not One Inch Scale Accordingly		<b>Kitsap County Public Works</b> 614 Division Street, MS 26 Port Orchard, WA 98366	<b>SILVERDALE CONVEYANCE SYSTEM AND PUMP STATION 4 UPGRADES SCHEDULE C</b>  <b>DEMOLITION AND TESC PLAN</b>	Drawing: <b>D-1C</b> Sheet: <b>36</b> of <b>117</b> File: P21-10530_D-1C Date: January 2023	
ISSUED FOR BID      01-2023      TF      RAD								
No.	Revision	Date	By	App'd				

Path: S:\Cadd\Kitsap County\21-10530 Silverdale Conveyance-PS-4 Upgr\Design\Drawings\DWG\21-10530\_D-2C PLO\date: Jan 06, 2023-03:19:09pm CAD User: solsoe  
 Xref Filename: I:\21-10530\_TB\Fisher\21-10530-PS4\_Ex\_Bldg\Detail\Palmtier

NORTH

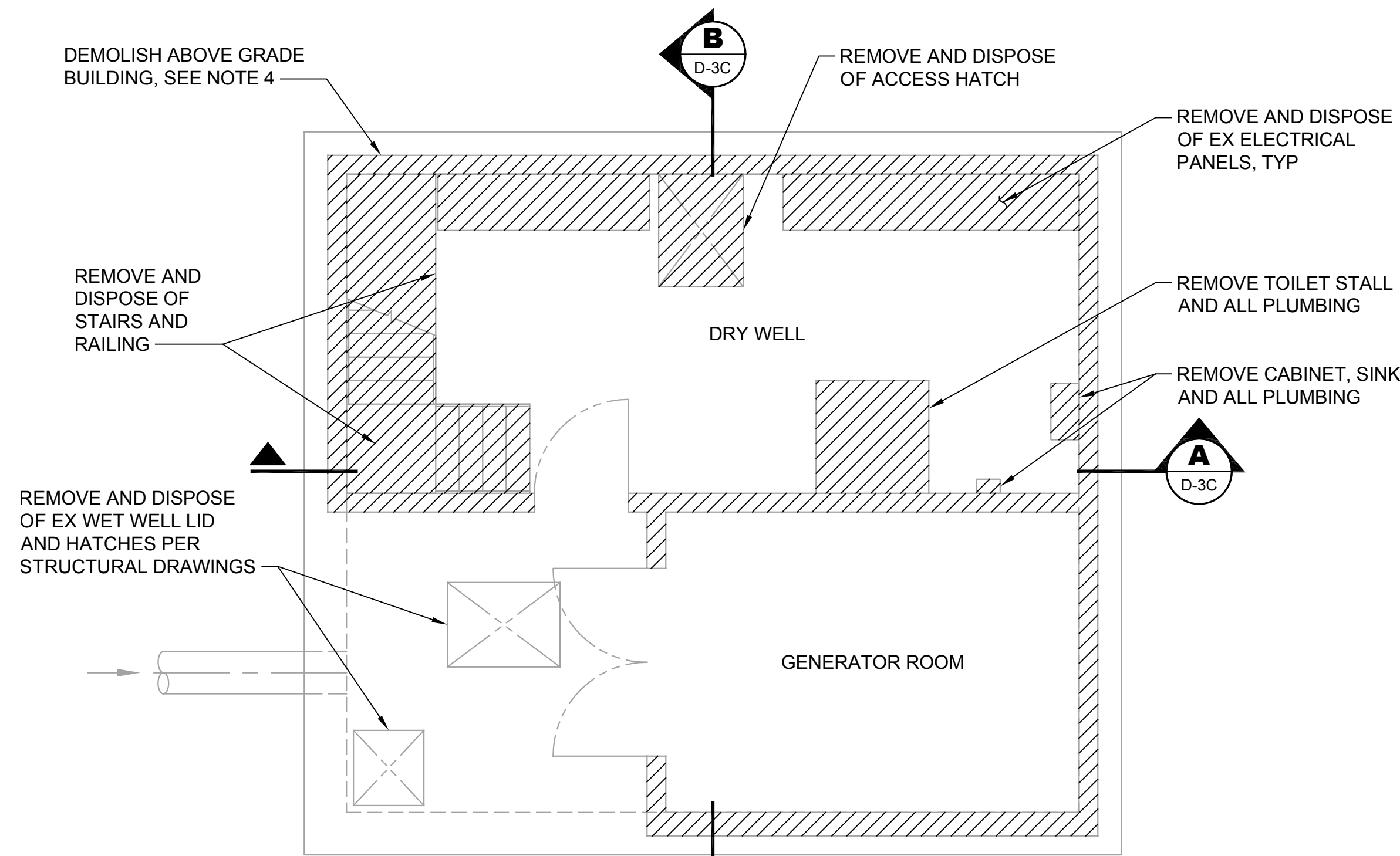

**EXISTING ABOVE GROUND FLOOR LEVEL PLAN**  
 SCALE: 1/4" = 1'-0"

NORTH

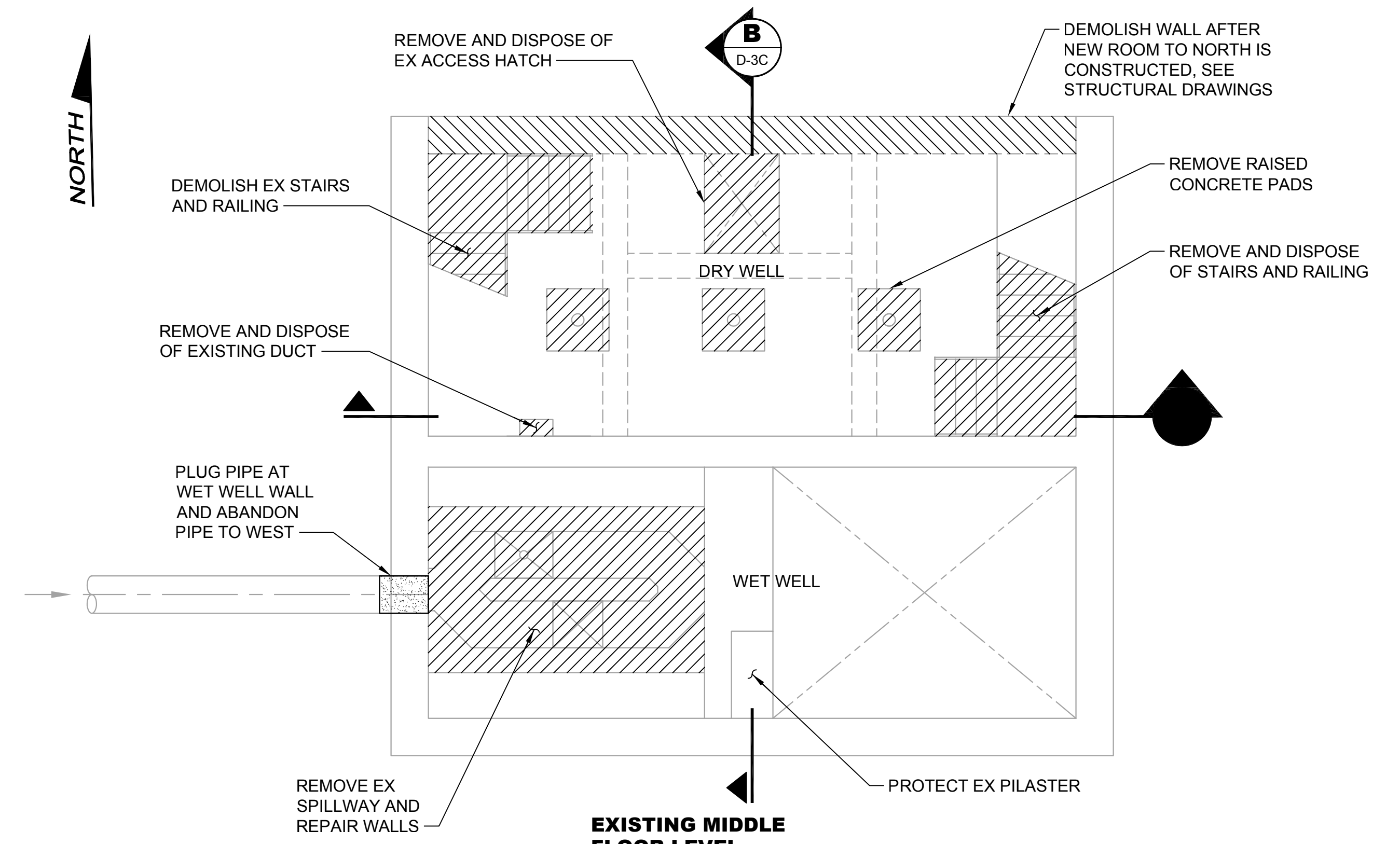

**EXISTING MIDDLE FLOOR LEVEL PLAN**  
 SCALE: 1/4" = 1'-0"

NORTH

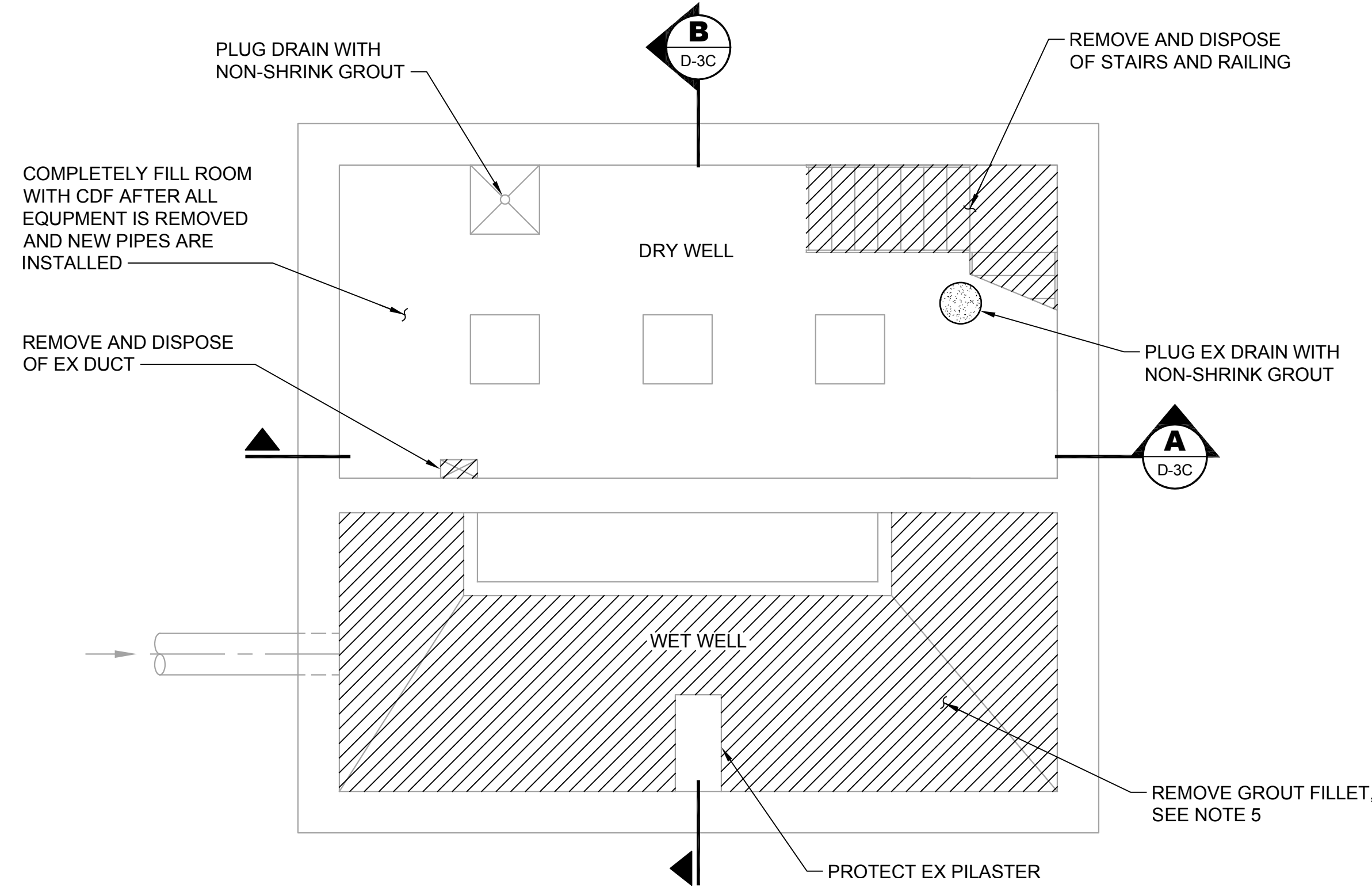

**LOWER LEVEL PLAN**  
 SCALE: 1/4" = 1'-0"

**NOTES:**

1. SEE DRAWING G-4 FOR CONSTRUCTION SEQUENCE REQUIREMENTS AND RESTRICTIONS.
2. REMOVE AND PROPERLY DISPOSE OF THE FOLLOWING IN ALL LEVELS OF THE DRY WELL.
  - A. ALL EQUIPMENT, PUMPS, PIPING, FITTINGS, VALVES, HVAC DUCTING, STAIRS, RAILING, AND ELECTRICAL HARDWARE AND LIGHTS.
  - B. DISCONNECT, REMOVE, AND PROPERLY DISPOSE OF ALL EX POWER AND CONTROL CIRCUITS AND CONDUCTORS.
  - C. FOR CONDUITS AND HVAC DUCTING THAT PENETRATE FLOORS OR WALLS, CUT THE CONDUIT/DUCTING CLOSE TO THE WALL AND FILL THE REMAINING VOIDS IN THE WALL/FLOOR WITH NON-SHRINK GROUT.
3. IN THE GENERATOR ROOM, REMOVE AND PROPERLY DISPOSE OF THE EX GENERATOR, EQUIPMENT, CONDUITS, CONDUCTORS, PANELS, AND OTHER APPURTENANCES.
4. DEMOLISH THE ENTIRE ABOVE GRADE BUILDING AND PROPERLY DISPOSE OF ALL DEBRIS.
5. IN THE THE EXISTING WET WELL:
  - A. REMOVE AND PROPERLY DISPOSE OF ALL GRATING, PIPING, SPILLWAYS, EQUIPMENT, LADDERS, SUPPORTS, MISCELLANEOUS, METALS, AND ELECTRICAL CONDUITS AND CONDUCTORS.
  - B. SAW CUT BREAKLINES IN EX GROUT FLOOR, THEN REMOVE WITH CHIPPING HAMMER
  - C. REMOVE AND REPLACE ACCESS HATCHES PER DRAWING C6-C.
6. REMOVE WALLS AND FLOOR OF EXISTING DRY WELL AND WET WELL AS NECESSARY TO ACCOMMODATE THE STRUCTURAL ELEMENTS SHOWN ON DWG S-4C.

**Call 48 Hours Before You Dig**  
 1-800-424-5555  
 UNDERGROUND SERVICE



**bhc CONSULTANTS**  
 BHC Consultants, LLC  
 1601 Fifth Avenue, Suite 500  
 Seattle, Washington 98101  
 206.505.3400  
 206.505.3406 (fax)  
 www.bhcconsultants.com

Designed: T. Fisher, P.E.  
 Drawn: J. Lira  
 Checked: R. Dorn, P.E.

Scale:  
 As Shown  
 One Inch at Full Scale  
 If Not One Inch Scale Accordingly

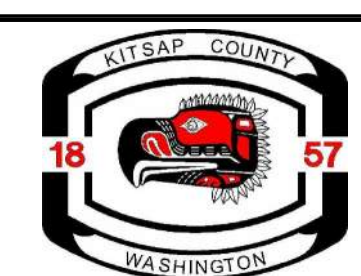

**Kitsap County Public Works**  
 614 Division Street, MS 26  
 Port Orchard, WA 98366

**SILVERDALE CONVEYANCE SYSTEM AND PUMP STATION 4 UPGRADES SCHEDULE C**

**DRY WELL / WET WELL DEMOLITION PLANS**

Drawing: **D-2C**  
 Sheet: **37** of **117**  
 File: P21-10530\_D-2C  
 Date: January 2023

Path: S:\Cad\Kitsap County\21-10530 Silverdale Convey-PS-4 Upgr\Design\Drawings\21-10530\_D-3C P10.dwg, Jan 06, 2023-03:21:31pm CAD User: solace.  
 Xref Filename: I:\21-10530\_TB\Fisher\21-10530-PS4\_Ex\_Bldg\_Draft\Palmtier

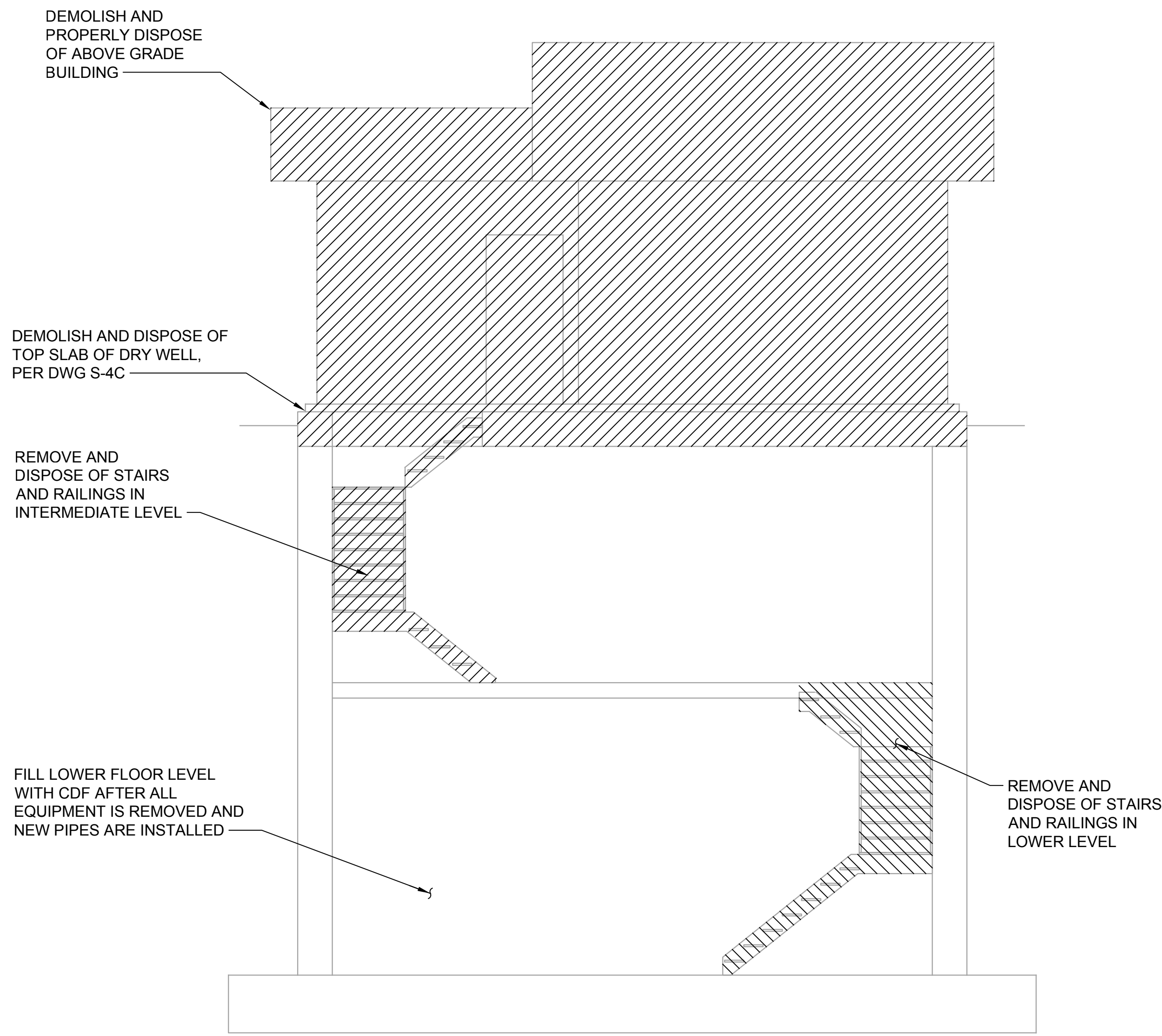

**SECTION A**  
 SCALE: 1/4" = 1'-0" D-2C

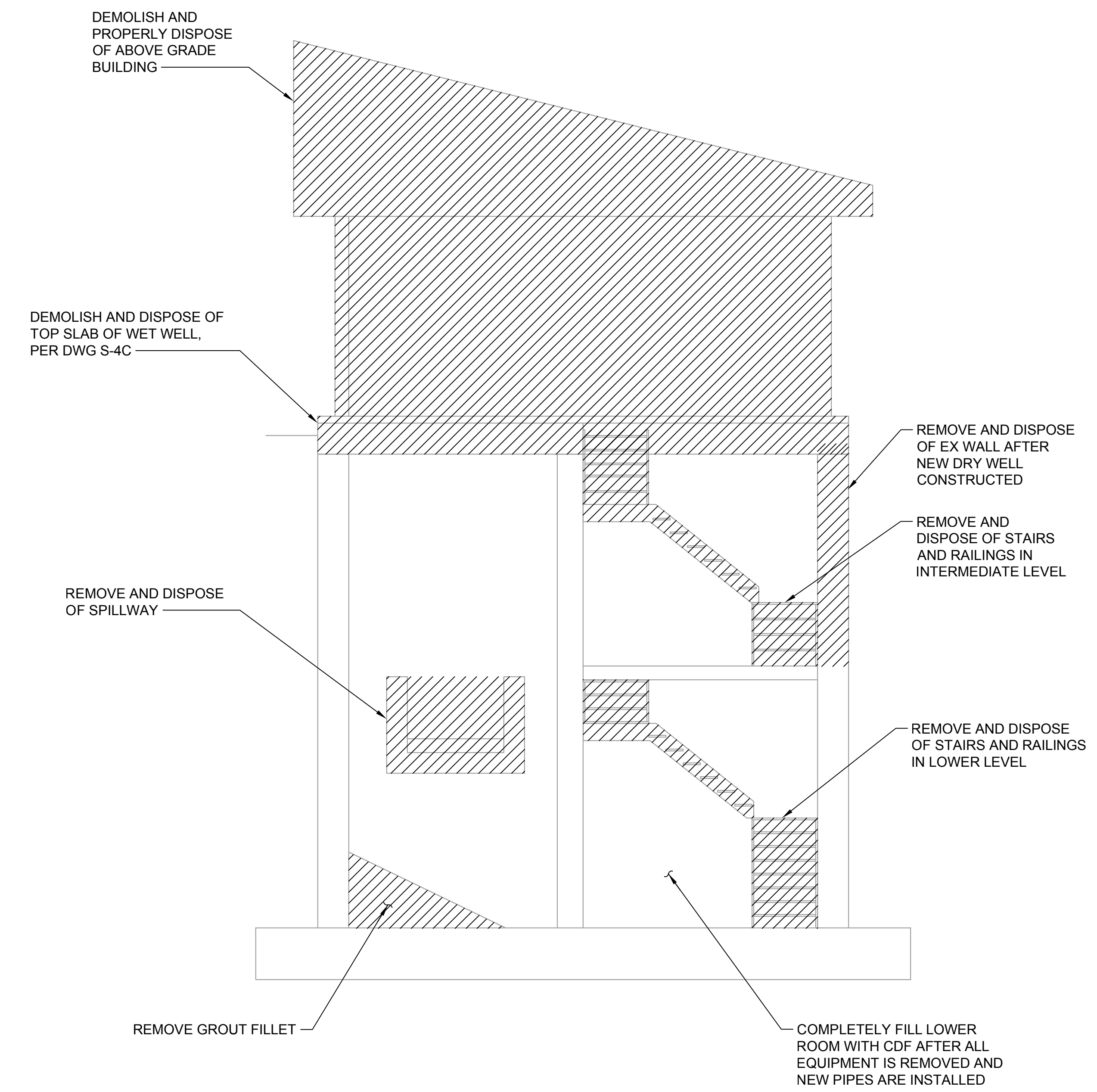

**SECTION B**  
 SCALE: 1/4" = 1'-0" D-2C

**Call 48 Hours Before You Dig**  
 1-800-424-5555  
 UNDERGROUND SERVICE

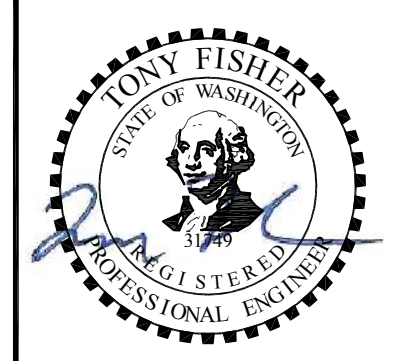

No.	Revision	Date	By	App'd
	ISSUED FOR BID	01-2023	TF	RAD

**bhc CONSULTANTS**  
**BHC Consultants, LLC**  
 1601 Fifth Avenue, Suite 500  
 Seattle, Washington 98101  
 206.505.3400  
 206.505.3406 (fax)  
 www.bhcconsultants.com

Designed: T. Fisher, P.E.  
 Drawn: J. Lira  
 Checked: R. Dorn, P.E.

Scale:  
 As Shown  
 One Inch at Full Scale  
 If Not One Inch Scale Accordingly



**Kitsap County Public Works**  
 614 Division Street, MS 26  
 Port Orchard, WA 98366

**SILVERDALE CONVEYANCE SYSTEM AND PUMP STATION 4 UPGRADES SCHEDULE C**  
**DRY WELL / WET WELL DEMOLITION SECTIONS**

Drawing: **D-3C**  
 Sheet: **38** of **117**  
 File: P21-10530\_D-3C  
 Date: January 2023

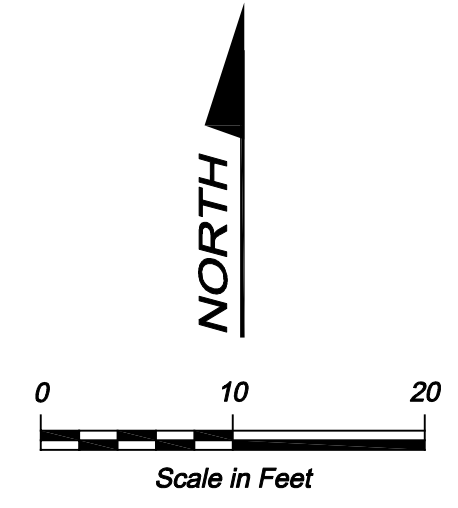

FREDRICKSON ROAD NW

Plat of  
BUCKLIN TERRACE  
Vol.9 Pg.22

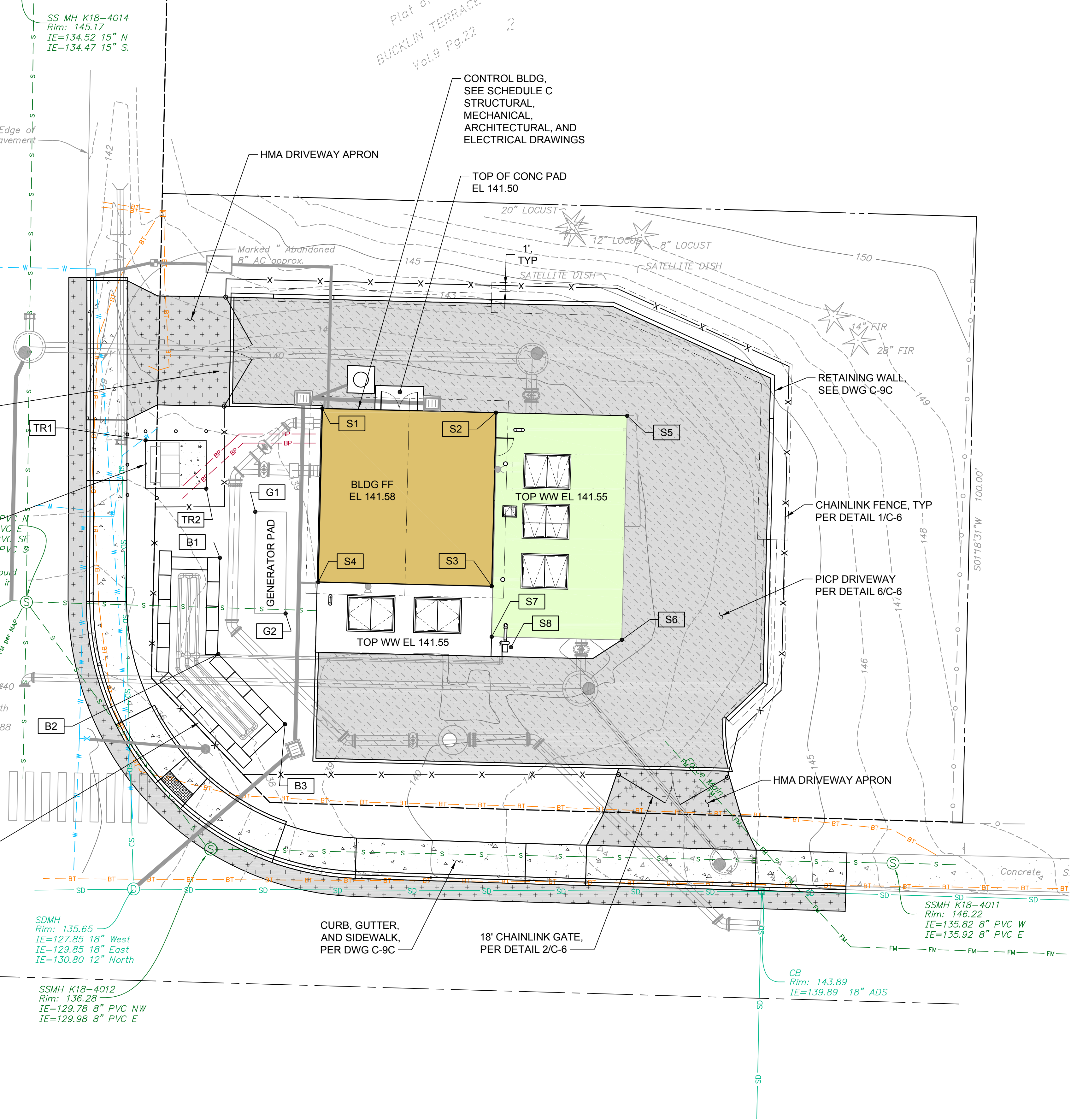

**NOTES:**

- 1. SEE DRAWING C-8C FOR GRADING AND DRAINAGE PLAN AND C-9C FOR RETAINING WALL AND SIDEWALK PLAN.

**COORDINATE CONTROL NOTES:**

- 1. SEE DWGS D-1C, C-2C, C-8C AND C-9C FOR ADDITIONAL COORDINATE POINTS.

STRUCTURE ELEVATION - COORDINATE CONTROL				
PT #	NORTHING	EASTING	ELEVATION	DESCRIPTION
S1	242796.53	1186611.40	141.08	GROUND AT BUILDING CORNER
S2	242795.84	1186640.06	141.28	GROUND AT BUILDING CORNER
S3	242767.18	1186639.37	141.55	BUILDING CORNER AT EX WET WELL
S4	242767.88	1186610.71	141.55	BUILDING CORNER AT EX WET WELL
S5	242795.32	1186661.72	141.43	GROUND AT WET WELL CORNER
S6	242758.33	1186660.83	141.10	GROUND AT WET WELL CORNER
S7	242758.85	1186639.36	141.55	WET WELL CORNER
S8	242757.30	1186641.30	141.55	TOP OF BIOFILTER FAN SLAB
SU1	242752.87	1186549.02	135.23	BENCH MARK #1
G1	242779.49	1186600.33	140.70	TOP OF GENERATOR PAD
G2	242762.68	1186605.33	140.70	TOP OF GENERATOR PAD
TR1	242791.26	1186582.21	140.20	TOP OF TRANSFORMER PAD
TR2	242783.29	1186592.24	140.20	TOP OF TRANSFORMER PAD
B1	242771.88	1186594.49		BIOFILTER BED WALL
B2	242756.00	1186594.22		BIOFILTER BED WALL
B3	242744.41	1186605.25		BIOFILTER BED WALL

Path: S:\CAD\Kitsap County\21-10530 Silverdale Conveyance-PS-4 Uprgr\Design\Drawings\21-10530\_C-1C\_P10.dwg, Jan 06, 2023, 05:52:17pm CAD User: solsoe  
Xref Filename: I:\Fisher\21-10530\_PSA\_Ext\_Topo\21-10530\_PSA\_Prop\_HMA\21-10530\_SCU\_Ext\_Topo\Drawn\Palmer\

No.	Revision	Date	By	App'd
	ISSUED FOR BID	01-2023	TF	RAD



**BHC Consultants, LLC**  
1601 Fifth Avenue, Suite 500  
Seattle, Washington 98101  
206.505.3400  
206.505.3406 (fax)  
www.bhcconsultants.com

Designed: T. Fisher, P.E.  
Drawn: P. Simon  
Checked: R. Dorn, P.E.

Scale:  
1" = 10'-0"  
One Inch at Full Scale  
If Not One Inch Scale Accordingly



**Kitsap County Public Works**  
614 Division Street, MS 26  
Port Orchard, WA 98366

**SILVERDALE CONVEYANCE SYSTEM AND PUMP STATION 4 UPGRADES**  
SCHEDULE C  
**SITE PLAN**

Drawing: **C-1C**  
Sheet: **39** of **117**  
File: P21-10530\_C-1C  
Date: January 2023

**Call 48 Hours Before You Dig**  
1-800-424-5555  
UNDERGROUND SERVICE

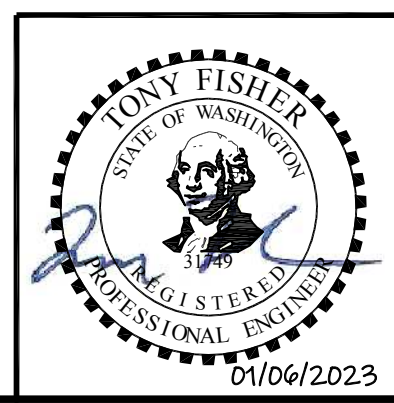

Plat of  
BUCKLIN TERRACE  
Vol.9 Pg.22

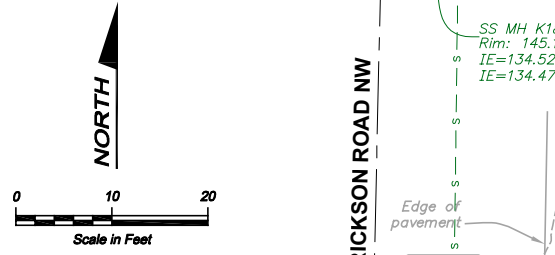

- NOTES:**
- 1. POTHOLE EXISTING SSFM AT CONNECTION POINT TO VERIFY ELEVATIONS.
  - 2. ALL NEW PIPE JOINTS ON PRESSURIZED PIPE AND ALL BURIED FITTINGS WITHIN THE PROJECT AREA SHALL BE RESTRAINED UNLESS NOTED OTHERWISE.
  - 3. SEE DRAWING C-8C FOR GRADING AND DRAINAGE PLAN AND DRAWING C-9C FOR RETAINING WALL AND SIDEWALK PLAN.
  - 4. MAINTAIN CONSTANT UPWARD SLOPE FROM CONNECTION POINT NEAR SSMH K18-4013 TO NEW SSMH. BEND PIPE PER MANUFACTURER'S RECOMMENDATIONS TO MAKE ENTRANCE INTO SSMH.
  - 5. SEE SCHEDULE A FOR 20" SSFM DOWNSTREAM OF BYPASS CONNECTION.

- COORDINATE CONTROL NOTES:**
- 1. SEE DWGS D-1C, C-1C, C-8C, AND C-9C FOR ADDITIONAL COORDINATE POINTS.

PIPE - COORDINATE CONTROL				
PT #	NORTHING	EASTING	INVERT/ELEVATION	DESCRIPTION
U1	242794.16	1186606.11	130.69	16" 45° BEND, MJ x MJ
U2	242785.52	1186597.03	130.52	20" 45° BEND, MJ x MJ
U3	242760.47	1186596.43	130.64	20" 45° BEND, MJ x MJ
U4	242741.66	1186615.61	130.78	20" 45° BEND, MJ x MJ
U5	242741.81	1186632.99	130.83	BYPASS STRUCTURE
U6	242741.92	1186646.40	130.87	20" 45° BEND, MJ x MJ
HB1	242820.32	1186594.36	143.0±	RPBV HOT BOX (TOP OF SLAB)

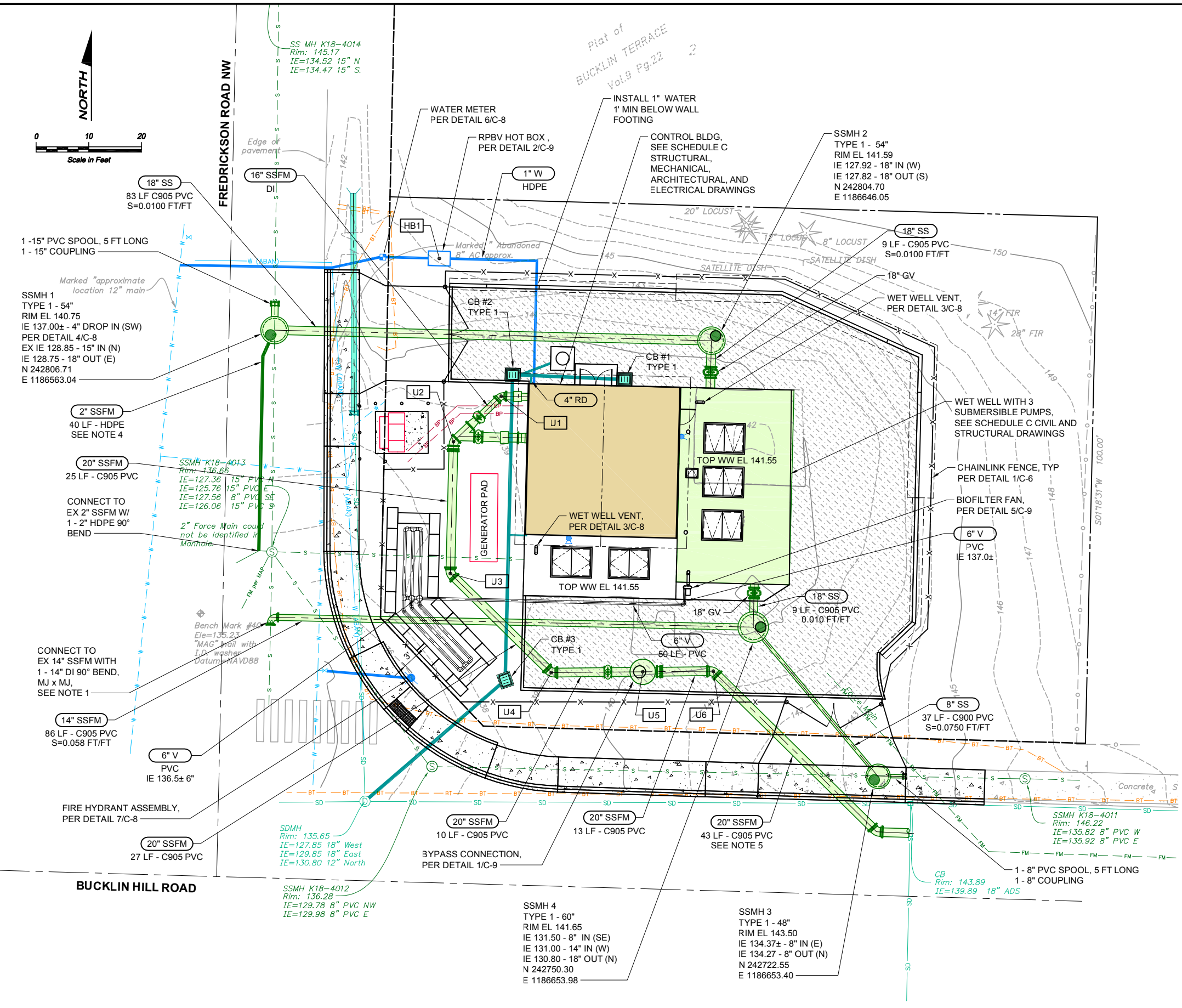

**Call 48 Hours Before You Dig**  
1-800-424-5555  
UNDERGROUND SERVICE

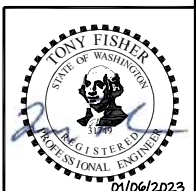

Path: S:\Cadd\Kitsap County\21-10530 Silverdale Conveyance PS 4 Uprgh Design\Drawings\21-10530 C-2C Plot date: Mar 20, 2023 09:06:04pm CAD User: solsoe  
Xref Filename: | Fisher | X21-10530\_TB | X21-10530-PS4\_Ext\_Topo | X21-10530-PS4\_Prop\_HMA | X21-10530-SCU\_Ext\_Topo | Dair | Palmtair |

No.	Revision	Date	By	App'd



**BHC Consultants, LLC**  
1601 Fifth Avenue, Suite 500  
Seattle, Washington 98101  
206.505.3400  
206.505.3406 (fax)  
www.bhcconsultants.com

Designed: T. Fisher, P.E.  
Drawn: P. Simon  
Checked: R. Dorn, P.E.

Scale:  
1" = 10'-0"  
One Inch at Full Scale  
If Not One Inch Scale Accordingly



**Kitsap County Public Works**  
614 Division Street, MS 26  
Port Orchard, WA 98366

**SILVERDALE CONVEYANCE SYSTEM AND PUMP STATION 4 UPGRADES**  
SCHEDULE C

**SITE PIPING PLAN**

Drawing: **C-2C**  
Sheet: **40** of **117**  
File: P21-10530\_C-2C  
Date: January 2023



Path: S:\Cadd\Kitsap County\21-10530 Silverdale Conveyance PS 4 Uprgn\Design\DWG\P21-10530\_C-3C\_Plot.dwg, Mar 20, 2023 03:10:06pm CAD User: solsoe.  
 Xref Filename: | X21-10530\_TB | Fisher | X21-10530-PS4\_Ext\_Bldg | X21-10530-PS4\_Prop\_Bldg | X21-10530-PS4\_Prop\_Mech | Dahli | Palmlatter |

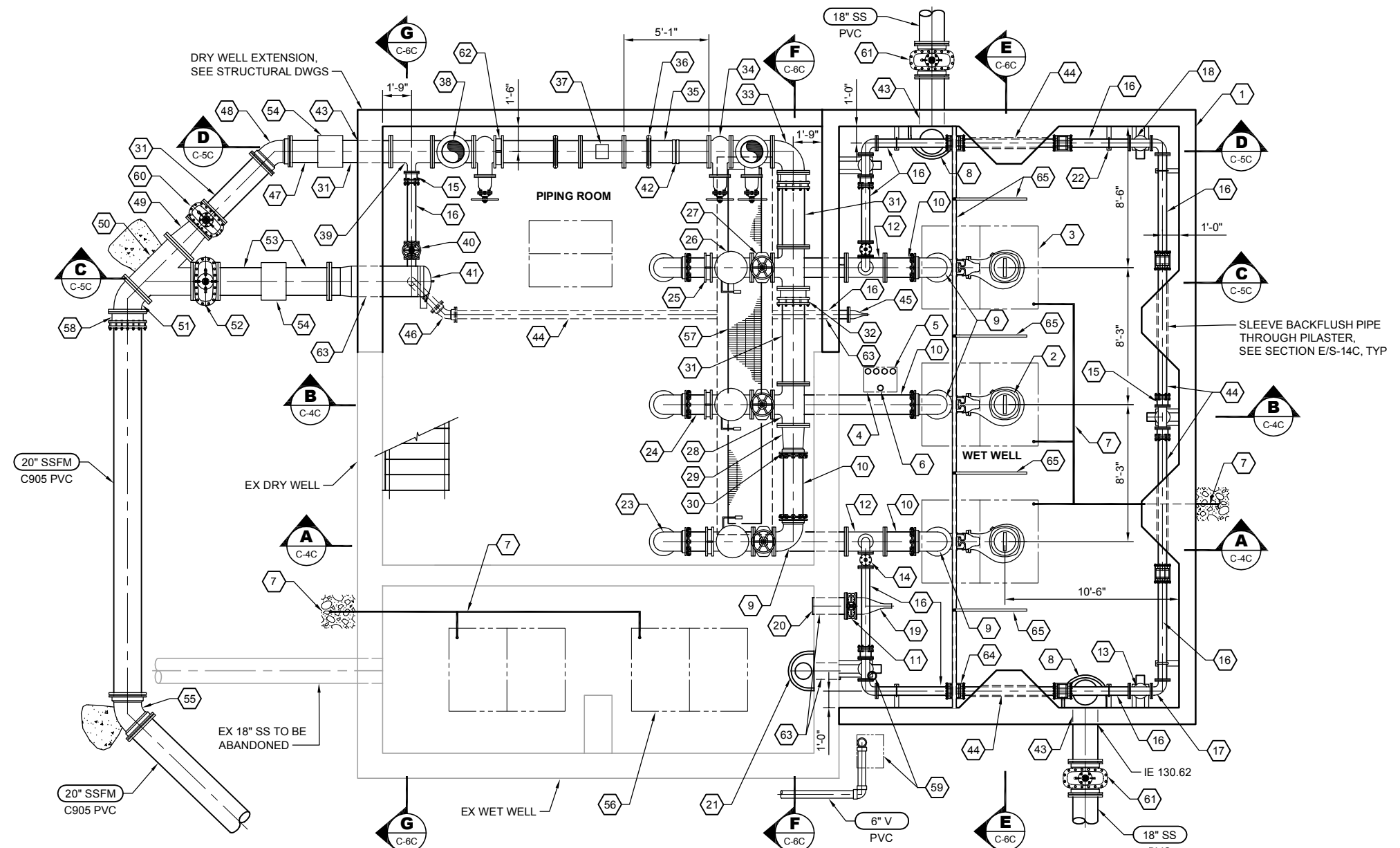

- NOTES:**
1. ALL DUCTILE IRON PIPE AND FITTINGS SHALL BE CLASS 52 AND LINED WITH PROTECTO 401.
  2. ALL BOLTED CONNECTIONS IN THE WET WELL SHALL BE CONSTRUCTED WITH DOUBLE 316L SST NUTS.
  3. ALL BELL AND SPIGOT, MECHANICAL, AND PLAIN END JOINTS SHALL BE RESTRAINED. ALL BURIED FITTINGS SHALL ALSO HAVE THRUST BLOCKS, UNLESS NOTED OTHERWISE.
  4. COORDINATE HATCH LOCATION WITH PUMP MANUFACTURER AND GUIDE RAILS TO AVOID CONFLICTS.
  5. ALL ACCESS HATCHES SHALL HAVE A SAFETY GRATE BY HATCH MANUFACTURER, UNLESS NOTED OTHERWISE. SAFETY GRATE SWING SHALL BE THE SAME AS THE HATCH DOOR.
  6. SEE STRUCTURAL DRAWINGS FOR LOCATIONS AND DETAILING OF LIFT/PULL POINTS IN CEILING OF PIPE ROOM THAT WILL BE USED TO FACILITATE MAINTENANCE ON THE MECHANICAL EQUIPMENT IN THE PIPE ROOM.

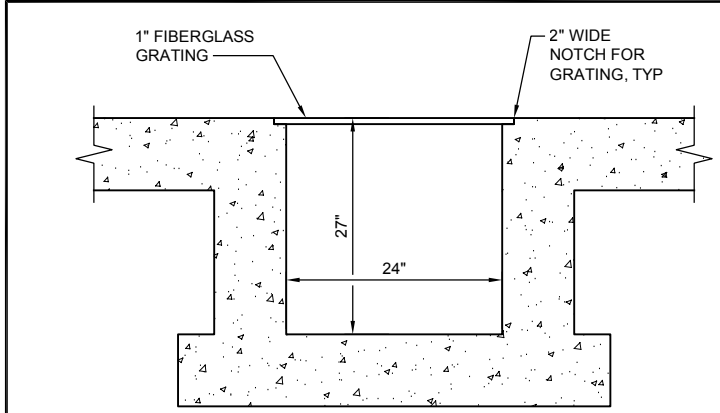

- NOTES:**
1. SEE STRUCTURAL DWGS FOR REINFORCING AND WALL THICKNESS.

**TRENCH DRAIN SECTION 1**  
 SCALE: 1/2" = 1'-0"

**PUMP STATION COMPONENTS**

- |  |  |  |  |   |
|--|--|--|--|---|
| 1 NEW WET WELL, SEE STRUCTURAL DRAWINGS  | 13 6" x 6" DI TEE, FL x FL, TYP OF 5                   | 28 16" x 14" DI TEE, FL x FL, TYP OF 2   | 42 16" DOUBLE STRAP SERVICE SADDLE WITH 2" OUTLET AND BRASS BALL VALVE, PLUMB AS NEEDED TO DRAIN TO TRENCH GRATE | 55 20" DI 45° BEND, MJ x MJ   |
| 2 SUBMERSIBLE PUMP, TYP OF 3   | 14 6" GV WITH VALVE BOX, FL x FL, TYP OF 2             | 29 16" x 14" DI REDUCER, FL x FL   | 43 WALL PENETRATION TYPE 1, PER DETAIL 7/C-7, CORE DRILL HOLE, MATCH PIPE SIZE                                   | 56 72" x 48" DOUBLE LEAF ALUMINUM ACCESS HATCH, H-30 RATED, TYP OF 2, SEE NOTE 5, DWG C-7C, AND STRUCTURAL DWGS |
| 3 84" x 60" DOUBLE LEAF ALUM ACCESS HATCH, H-30 RATED, TYP OF 3, SEE NOTES 4 AND 5, DWG C-7C, AND STRUCTURAL DWGS                          | 15 6" RESTRAINED FLANGE COUPLING ADAPTOR, TYP OF 5     | 30 14" RESTRAINED FLANGE COUPLING ADAPTOR  | 44 6" DI SPOOL, PE x PE, LENGTH AS REQUIRED  | 57 TRENCH DRAIN, SEE DETAIL 1/-   |
| 4 18" x 24" SINGLE LEAF ALUM ACCESS HATCH WITH REMOVABLE SAFETY NET, BUT NO SLAM LOCK, SPRING ASSIST CYLINDER, OR PADLOCK HASP, H-30 RATED | 16 6" DI SPOOL, FL x PE, LENGTH AS REQUIRED            | 31 16" DI SPOOL, FL x PE, LENGTH AS REQUIRED   | 45 6" DUCKBILL TYPE CHECK VALVE, FL CONNECTION   | 58 20" RESTRAINED FLANGE COUPLING ADAPTOR   |
| 5 FLOAT SWITCH ASSEMBLY, SEE ELECTRICAL DRAWINGS FOR DETAILS   | 17 6" DI 90° BEND, FL x FL, TYP OF 6                   | 32 16" RESTRAINED FLANGE COUPLING ADAPTOR, TYP OF 2  | 46 6" DI 45° BEND, MJ x MJ   | 59 6" C900 PVC VENT PIPE AND BIOFILTER FAN (ABOVE), PER DETAIL 5/C-9  |
| 6 PRESSURE SENSING LEVEL PROBE, SEE ELECTRICAL DRAWINGS FOR DETAILS  | 18 6" BACKFLUSH PIPE, PER DETAIL 1/C-7, TYP OF 5       | 33 16" DI 90° BEND, FL x FL  | 47 16" DI SPOOL, PE x PE, LENGTH AS REQUIRED   | 60 16" GV WITH VALVE BOX, FL x FL   |
| 7 HATCH DRAIN, 1 1/2" SCH 80 PVC, PER DETAIL 2/C-5   | 19 12" DUCKBILL TYPE CHECK VALVE, FL CONNECTION        | 34 16" GV WITH HANDWHEEL, FL x FL, TYP OF 3  | 48 16" DI 45° BEND, MJ x MJ  | 61 18" GV WITH VALVE BOX, MJ x MJ   |
| 8 18" INSIDE DROP CONNECTION, PER DETAIL 4/C-8   | 20 12" DI SPOOL, FL x PE, LENGTH AS REQUIRED           | 35 16" DI SPOOL, FL x GRV, LENGTH AS REQUIRED, TYP OF 4  | 49 20" x 16" DI REDUCER, FL x FL   | 62 16" PRESSURE INDICATOR, PER DETAIL 1/C-8   |
| 9 14" DI 90° BEND, FL x MJ   | 21 12" INSIDE DROP, SEE DETAIL 4/C-8                   | 36 16" VICTAULIC COUPLING, TYP OF 2  | 50 20" x 20" DI WYE, FL x FL   | 63 WALL PENETRATION TYPE 2, PER DETAIL 8/C-7, CORE DRILL HOLE, MATCH PIPE SIZE, TYP OF 5                        |
| 10 14" DI SPOOL, FL x PE, LENGTH AS REQUIRED   | 22 PIPE SUPPORT TYPE 2, SEE DETAIL 3/C-7, TYP OF 6     | 37 16" MAGNETIC FLOW METER, FL x FL WITH 16" DI SPOOL, FL x FL SPOOL TO MATCH LAY LENGTH OF FLOW METER | 51 20" DI 45° BEND, FL x FL  | 64 6" RESTRAINED COUPLING, TYP OF 6   |
| 11 12" GATE VALVE, FL x FL   | 23 14" DI 90° BEND, MJ x MJ, TYP OF 3                  | 38 16" x 16" DI VERTICAL TEE, TYP OF 2   | 52 20" GV WITH VALVE BOX, FL x FL  | 65 INTERMEDIATE GUIDE RAIL SUPPORTS, SEE STRUCTURAL DRAWINGS  |
| 12 14" x 6" DI VERTICAL TEE, FL x FL, TYP OF 2   | 24 14" DI SPOOL, FL x PE, LENGTH AS REQUIRED, TYP OF 3 | 39 16" x 6" DI TEE, FL x FL  | 53 20" DI SPOOL, FL x PE, LENGTH AS REQUIRED   |   |
|  | 25 14" PRESSURE INDICATOR, PER DETAIL 1/C-8, TYP OF 3  | 40 6" GV WITH HANDWHEEL, FL x FL   | 54 ROMAC ALPHA RESTRAINED FLEXIBLE COUPLING OR ACCEPTED EQUAL, MATCH PIPE SIZE                                   |   |
|  | 26 14" CHECK VALVE, FL x FL, TYP OF 3                  | 41 20" PIG LAUNCH, PER DETAIL 5/C-8  |  |   |
|  | 27 14" GV WITH HANDWHEEL, FL x FL, TYP OF 3            |  |  |   |

No.	Revision	Date	By	App'd
		01-2023	TF	RAD
	ISSUED FOR BID			

**bhc CONSULTANTS**  
 BHC Consultants, LLC  
 1601 Fifth Avenue, Suite 500  
 Seattle, Washington 98101  
 206.505.3400  
 206.505.3406 (fax)  
 www.bhcconsultants.com

Designed: T. Fisher, P.E.  
 Drawn: P. Simon  
 Checked: R. Dorn, P.E.  
 Scale: 1/4" = 1'-0"  
 One Inch at Full Scale  
 If Not One Inch Scale Accordingly

**Kitsap County Public Works**  
 614 Division Street, MS 26  
 Port Orchard, WA 98366

**SILVERDALE CONVEYANCE SYSTEM AND PUMP STATION 4 UPGRADES SCHEDULE C**  
**CONTROL BUILDING PIPING ROOM AND WET WELL PLAN**

Drawing: **C-3C**  
 Sheet: **41** of **117**  
 File: P21-10530\_C-3C  
 Date: January 2023

**Call 48 Hours Before You Dig**  
 1-800-424-5555  
 UNDERGROUND SERVICE

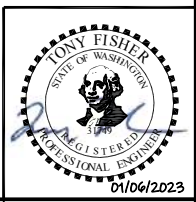

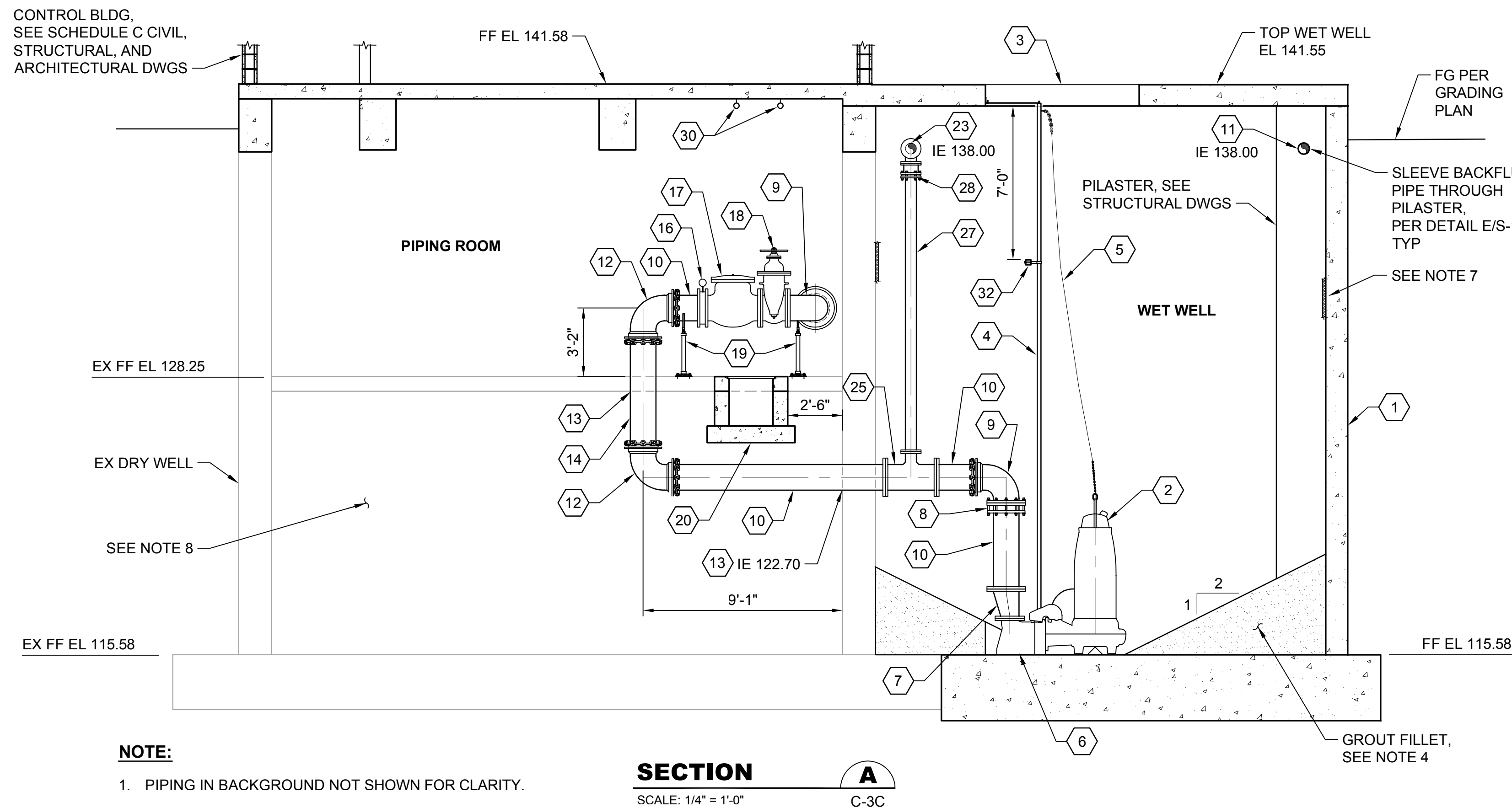

**PUMP STATION COMPONENTS**

- 1 36' x 24' WET WELL, SEE STRUCTURAL DRAWINGS
- 2 SUBMERSIBLE PUMP
- 3 84" x 60" DOUBLE LEAF ALUM ACCESS HATCH, H-30 RATED, SEE NOTES 5 AND 6, DWG C-7C, AND STRUCTURAL DWGS
- 4 GUIDE RAIL SYSTEM, SIZE PER PUMP MANUFACTURER, SCH 40 316L SST FURNISHED AND INSTALLED BY CONTRACTOR
- 5 316L SST PUMP LIFTING CHAIN WITH HOLDER
- 6 8" DISCHARGE ELBOW (INCLUDED WITH PUMP)
- 7 14" x 10" DI ECCENTRIC REDUCER, FL x FL
- 8 14" FLANGED COUPLING ADAPTOR, FL x MJ
- 9 14" DI 90° BEND, FL x MJ
- 10 14" DI SPOOL, FL x PE, LENGTH AS REQUIRED
- 11 6" DI SPOOL, PE x PE, LENGTH AS REQUIRED
- 12 14" DI 90° BEND, MJ x MJ
- 13 WALL/FLOOR PENETRATION TYPE 2, PER DETAIL 8/C-7
- 14 14" DI SPOOL, PE x PE, LENGTH AS REQUIRED
- 15 14" DI SPOOL, FL x FL, LENGTH AS REQUIRED
- 16 14" PRESSURE INDICATOR, PER DETAIL 1/C-8
- 17 14" CHECK VALVE, FL x FL
- 18 14" GV WITH HANDWHEEL
- 19 PIPE SUPPORT TYPE 1, PER DETAIL 2/C-7, TYP
- 20 TRENCH DRAIN, SEE DETAIL 1/C-3C
- 21 PIPE SUPPORT TYPE 2, PER DETAIL 3/C-7
- 22 SST SUPPORT CABLE, SEE ELECTRICAL DRAWINGS
- 23 6" DI 90° BEND, FL x FL, IE 138.0±, TYP
- 24 6" BACKFLUSH PIPE, PER DETAIL 1/C-7
- 25 14" x 6" DI TEE, FL x FL
- 26 16" x 14" DI TEE, FL x FL
- 27 6" DI SPOOL, FL x PE, LENGTH AS REQUIRED
- 28 6" RESTRAINED FLANGE COUPLING ADAPTOR
- 29 LEVEL TRANSMITTER, SEE ELECTRICAL DRAWINGS
- 30 PICK POINT, SEE DRAWING C-7C AND STRUCTURAL DRAWINGS FOR AND LOCATIONS AND DETAILS
- 31 6" x 6" DI TEE, FL x FL
- 32 INTERMEDIATE GUIDE RAIL SUPPORTS, SEE STRUCTURAL DRAWINGS

**NOTES:**

- 1. ALL DUCTILE IRON PIPE AND FITTINGS SHALL BE CLASS 52 AND LINED WITH PROTECTO 401.
- 2. ALL BOLTED CONNECTIONS IN THE WET WELL SHALL BE CONSTRUCTED WITH DOUBLE 316L SST NUTS.
- 3. ALL BELL AND SPIGOT, MECHANICAL, AND PLAIN END JOINTS SHALL BE RESTRAINED.
- 4. ADJUST DIMENSIONS OF FLAT AREA AND GROUDED FILLETS AROUND PUMPS, DISCHARGE ELBOW, PRESSURE SENSING LEVEL PROBE, AND LEVEL FLOATS TO PROVIDE 6 INCHES CLEARANCE.
- 5. COORDINATE HATCH LOCATION WITH PUMP MANUFACTURER AND GUIDE RAILS TO AVOID CONFLICTS.
- 6. ALL ACCESS HATCHES SHALL HAVE A SAFETY GRATE BY HATCH MANUFACTURER, UNLESS NOTED OTHERWISE. SAFETY GRATE SWING SHALL BE THE SAME AS THE HATCH DOOR.
- 7. CLEAN INTERIOR OF WET WELL AND COAT WITH INTERIOR COATING SYSTEM C PER SPECIFICATIONS. INSTALL FILLETS PRIOR TO COATING THE WET WELL.
- 8. COMPLETELY FILL LOWER LEVEL WITH CDF FOLLOWING INSTALLATION AND TESTING OF NEW PIPE.

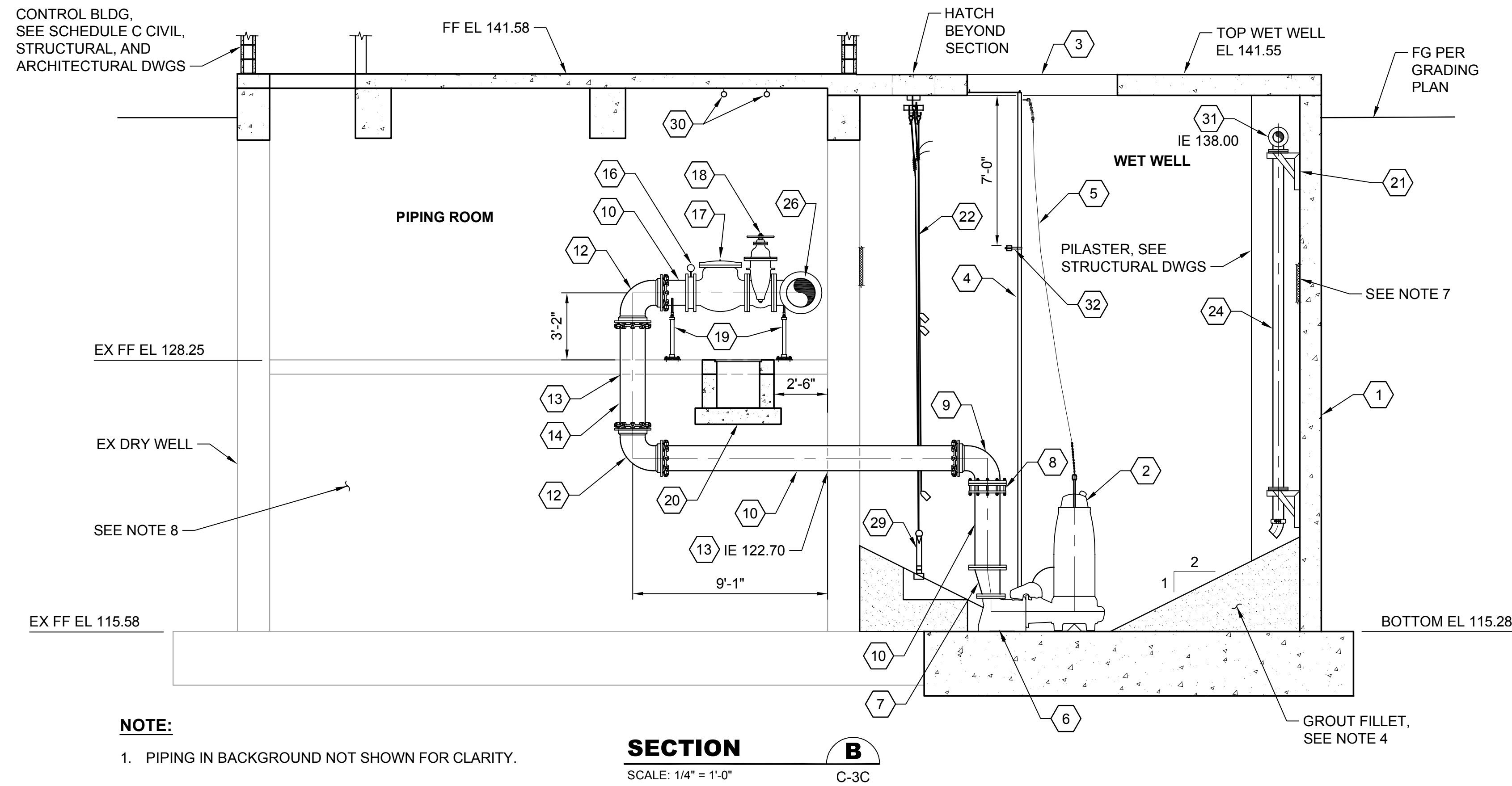

**Call 48 Hours Before You Dig**  
1-800-424-5555  
UNDERGROUND SERVICE

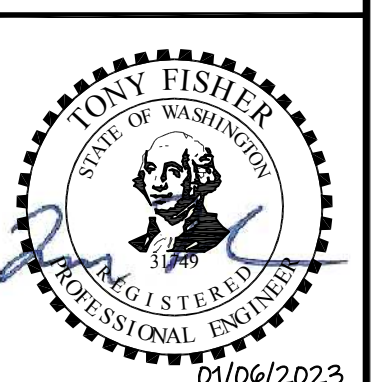

Path: S:\cad\Kitsap County\21-10530 Silverdale Conveyance-PS-4 Uprgr\Design\Drawings\21-10530-C-4C\_PIPING.dwg, Jan 06, 2023, 03:19:30pm CAD User: JLiRa  
Xref Filenames: I:\21-10530\_TB | Fisher | X21-10530-PS4\_Ex Bldg | X21-10530-PS4\_Prop Bldg | X21-10530-PS4\_Prop Mech | Dain | Palmater |

No.	Revision	Date	By	App'd

**bhc**  
CONSULTANTS

**BHC Consultants, LLC**  
1601 Fifth Avenue, Suite 500  
Seattle, Washington 98101  
206.505.3400  
206.505.3406 (fax)  
www.bhcconsultants.com

Designed: T. Fisher, P.E.  
Drawn: P. Simon  
Checked: R. Dorn, P.E.

Scale:  
1/4" = 1'-0"  
One Inch at Full Scale  
If Not One Inch Scale Accordingly

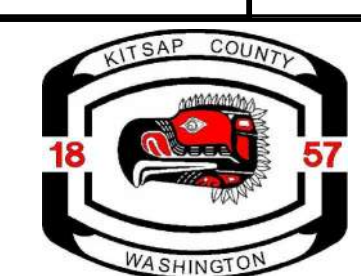

**Kitsap County Public Works**  
614 Division Street, MS 26  
Port Orchard, WA 98366

**SILVERDALE CONVEYANCE SYSTEM AND PUMP STATION 4 UPGRADES**  
SCHEDULE C  
**CONTROL BUILDING**  
**PIPING ROOM AND WET WELL SECTIONS**  
**1 OF 3**

Drawing: **C-4C**  
Sheet: **42** of **117**  
File: P21-10530\_C-4C  
Date: January 2023

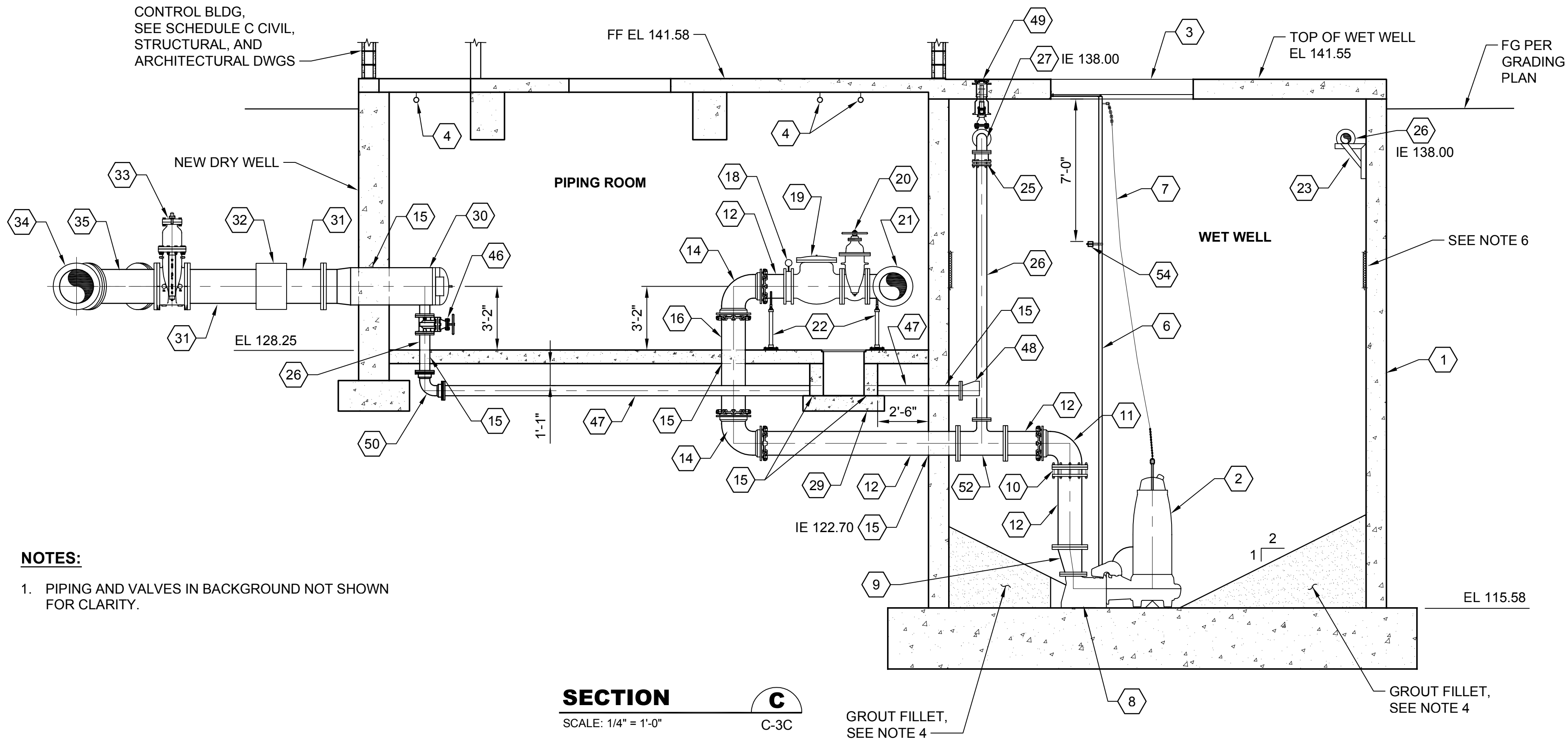

- NOTES:**
1. PIPING AND VALVES IN BACKGROUND NOT SHOWN FOR CLARITY.

**SECTION C-C**  
SCALE: 1/4" = 1'-0"

**PUMP STATION COMPONENTS**

- 1 36" x 24" WET WELL, SEE STRUCTURAL DRAWINGS
- 2 SUBMERSIBLE PUMP
- 3 84" x 60" DOUBLE LEAF ALUM ACCESS HATCH, H-30 RATED, SEE NOTES 5 AND 6, DWG C-7C, AND STRUCTURAL DWGS
- 4 PICK POINT, SEE DRAWING C-7C AND STRUCTURAL DRAWINGS FOR LOCATIONS AND DETAILS
- 5 18" INSIDE DROP, PER DETAIL 4/C-8
- 6 GUIDE RAIL SYSTEM, SIZE PER PUMP MANUFACTURER, SCH 40 316L SST FURNISHED AND INSTALLED BY CONTRACTOR
- 7 316L SST PUMP LIFTING CHAIN WITH HOLDER
- 8 8" DISCHARGE ELBOW (INCLUDED WITH PUMP)
- 9 14" x 10" DI ECCENTRIC REDUCER, FL x FL
- 10 14" FLANGED COUPLING ADAPTOR, FL x MJ
- 11 14" DI 90° BEND, FL x MJ
- 12 14" DI SPOOL, FL x PE, LENGTH AS REQUIRED
- 13 6" RESTRAINED COUPLING
- 14 14" DI 90° BEND, MJ x MJ
- 15 WALL/FLOOR PENETRATION TYPE 2, PER DETAIL 8/C-7
- 16 14" DI SPOOL, PE x PE, LENGTH AS REQUIRED
- 17 16" DI 90° BEND, FL X MJ
- 18 14" PRESSURE INDICATOR, PER DETAIL 3/C-8
- 19 14" CHECK VALVE, FL x FL
- 20 14" GV WITH HANDWHEEL, FL x FL
- 21 16" x 14" DI TEE, FL x FL
- 22 PIPE SUPPORT TYPE 1, PER DETAIL 2/C-7
- 23 PIPE SUPPORT TYPE 2, PER DETAIL 3/C-7, TYP
- 24 6" x 6" DI TEE, FL x FL
- 25 6" RESTRAINED FLANGE COUPLING ADAPTOR
- 26 6" DI SPOOL, FL x PE, LENGTH AS REQUIRED
- 27 6" DI 90° BEND, FL x FL
- 28 6" BACKFLUSH PIPE, PER DETAIL 1/C-7
- 29 TRENCH DRAIN, SEE DETAIL 1/C-3C
- 30 20" PIG LAUNCH, PER DETAIL 5/C-8
- 31 20" DI SPOOL, FL x PE, LENGTH AS REQUIRED
- 32 ROMAC ALPHA RESTRAINED FLEXIBLE COUPLING OR ACCEPTED EQUAL, MATCH PIPE SIZE
- 33 20" GV WITH VALVE BOX, FL x FL
- 34 20" DI 45° BEND, FL x FL
- 35 20" x 20" DI WYE, FL x FL
- 36 16" DI 90° BEND, FL x FL
- 37 16" x 16" DI TEE, FL x FL
- 38 16" GV WITH HANDWHEEL, FL x FL, TYP OF 3
- 39 16" DI SPOOL, FL x GV, LENGTH AS REQUIRED, TYP OF 4
- 40 16" VICTAULIC COUPLING, TYP OF 2
- 41 16" MAGNETIC FLOW METER, FL x FL WITH 16" DI SPOOL, FL x FL, SPOOL TO MATCH LAY LENGTH OF FLOW METER
- 42 16" x 6" DI TEE, FL x FL
- 43 16" DI SPOOL, FL x PE, LENGTH AS REQUIRED
- 44 16" DI 45° BEND, MJ x MJ
- 45 16" DI SPOOL, PE x PE, LENGTH AS REQUIRED
- 46 6" GV WITH HANDWHEEL, FL x FL
- 47 6" SPOOL, PE x PE, LENGTH AS REQUIRED

**NOTES:**

1. ALL DUCTILE IRON PIPE AND FITTINGS SHALL BE CLASS 52 AND LINED WITH PROTECTO 401.
2. ALL BOLTED CONNECTIONS IN THE WET WELL SHALL BE CONSTRUCTED WITH DOUBLE 316L SST NUTS.
3. ALL BELL AND SPIGOT, MECHANICAL, AND PLAIN END JOINTS SHALL BE RESTRAINED.
4. ADJUST DIMENSIONS OF FLAT AREA AND GROUTED FILLETS AROUND PUMPS, DISCHARGE ELBOW, PRESSURE SENSING LEVEL PROBE, AND LEVEL FLOATS TO PROVIDE 6 INCHES CLEARANCE.
5. COORDINATE HATCH LOCATION WITH PUMP MANUFACTURER AND GUIDE RAILS TO AVOID CONFLICTS.
6. ALL ACCESS HATCHES SHALL HAVE A SAFETY GRATE BY HATCH MANUFACTURER UNLESS NOTED OTHERWISE. SAFETY GRATE SWING SHALL BE THE SAME AS THE HATCH DOOR.
7. CLEAN INTERIOR OF WET WELL AND COAT WITH INTERIOR COATING SYSTEM C PER SECTION 099600 OF THE SPECIFICATIONS. INSTALL FILLETS PRIOR TO COATING THE WET WELL.

- 48 6" DUCKBILL TYPE CHECK VALVE, SLIP ON CONFIGURATION
- 49 6" GV WITH VALVE BOX, FL x FL
- 50 6" DI 90° BEND, MJ x MJ
- 51 16" PRESSURE INDICATOR, PER DETAIL 3/C-8
- 52 14" x 6" DI TEE, FL x FL
- 53 16" DOUBLE STRAP SERVICE SADDLE WITH 2" OUTLET AND BRASS BALL VALVE, PLUMP AS NEEDED TO DRAIN TO TRENCH GRATE
- 54 INTERMEDIATE GUIDE RAIL SUPPORTS, SEE STRUCTURAL DRAWINGS

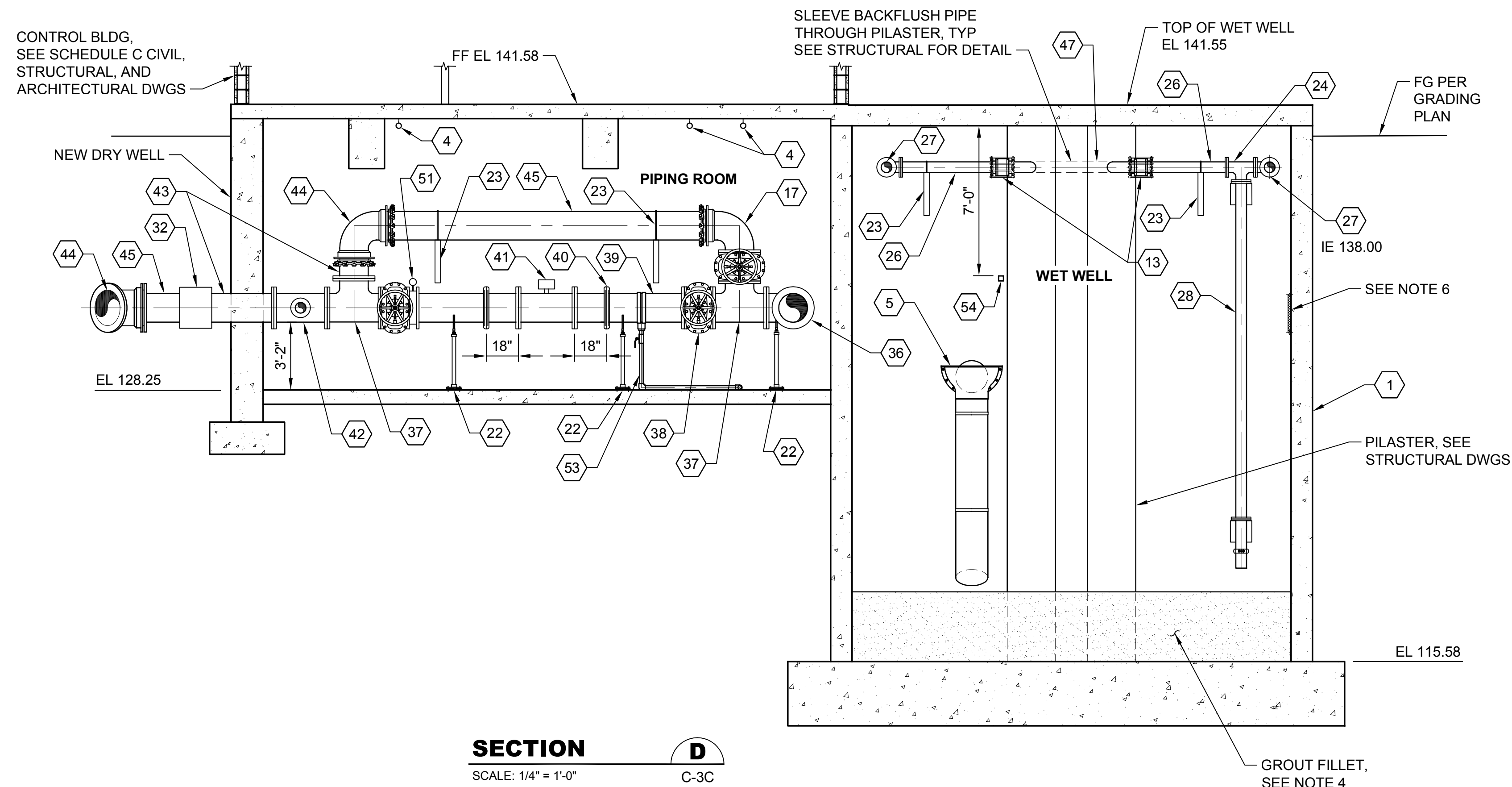

**SECTION D-D**  
SCALE: 1/4" = 1'-0"

**Call 48 Hours Before You Dig**  
1-800-424-5555  
UNDERGROUND SERVICE



Path: S:\Cadd\Kitsap County\21-10530 Silverdale Conveyance PS 4 Uprgr\Design\DWG\21-10530\_C-5C\_PIP.dwg, Date: Jan 06, 2023, 03:35:19pm, CAD User: J.Lira, Xref Filename: 21-10530\_TB | Fisher | 21-10530-PS4\_Ex Bldg | 21-10530-PS4\_Prop Bldg | 21-10530-PS4\_Prop Mech | Dahi | Palmater

No.	Revision	Date	By	App'd
	ISSUED FOR BID	01-2023	TF	RAD

**bhc CONSULTANTS**  
BHC Consultants, LLC  
1601 Fifth Avenue, Suite 500  
Seattle, Washington 98101  
206.505.3400  
206.505.3406 (fax)  
www.bhcconsultants.com

Designed: T. Fisher, P.E.  
Drawn: P. Simon  
Checked: R. Dorn, P.E.

Scale:  
1/4" = 1'-0"  
One Inch at Full Scale  
If Not One Inch Scale Accordingly



**Kitsap County Public Works**  
614 Division Street, MS 26  
Port Orchard, WA 98366

**SILVERDALE CONVEYANCE SYSTEM AND PUMP STATION 4 UPGRADES**  
SCHEDULE C  
**CONTROL BUILDING**  
**PIPING ROOM AND WET WELL SECTIONS**  
2 OF 3

Drawing: **C-5C**  
Sheet: **43** of **117**  
File: P21-10530\_C-5C  
Date: January 2023

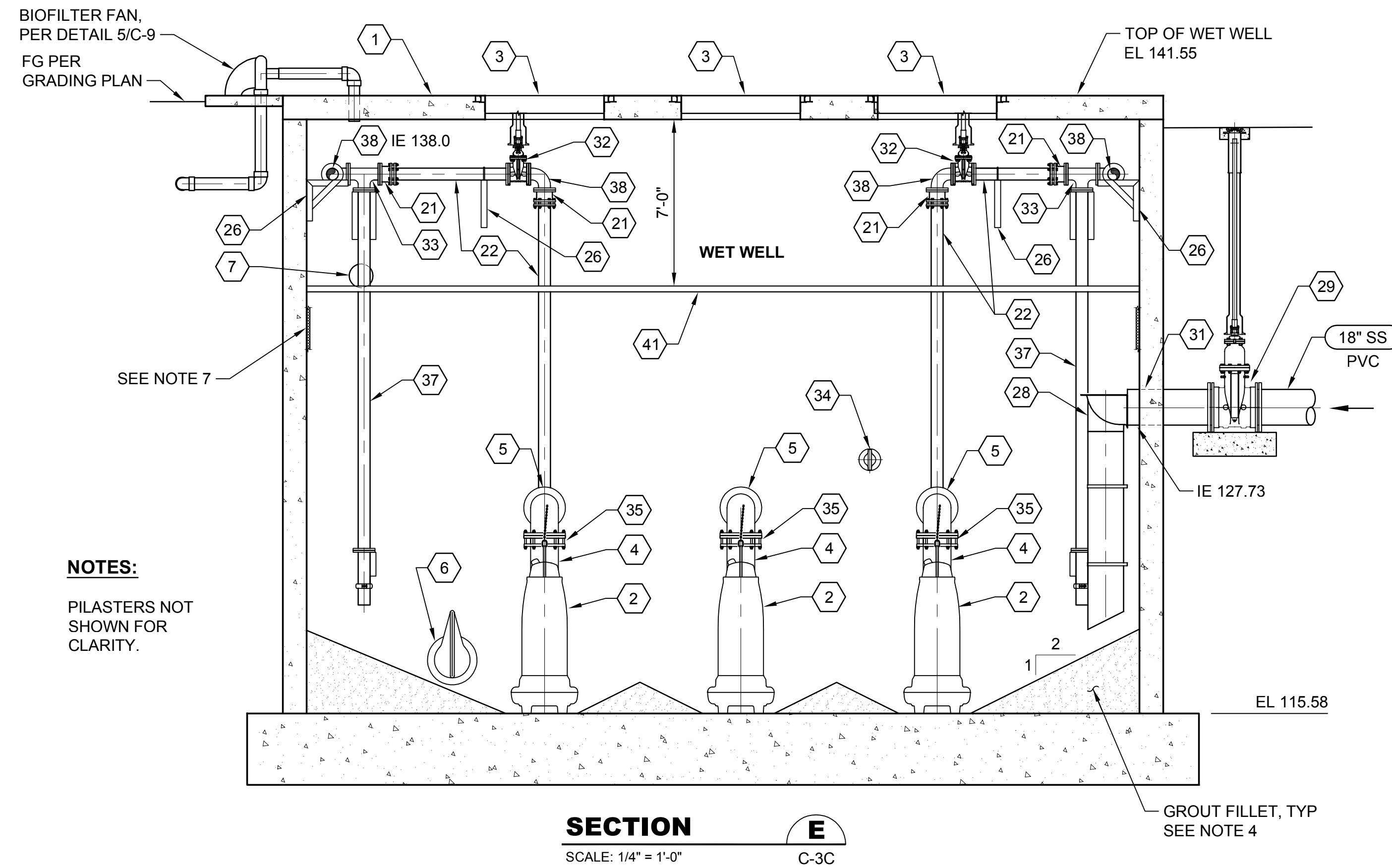

**NOTES:**  
PILASTERS NOT SHOWN FOR CLARITY.

**SECTION E**  
SCALE: 1/4" = 1'-0"  
C-3C

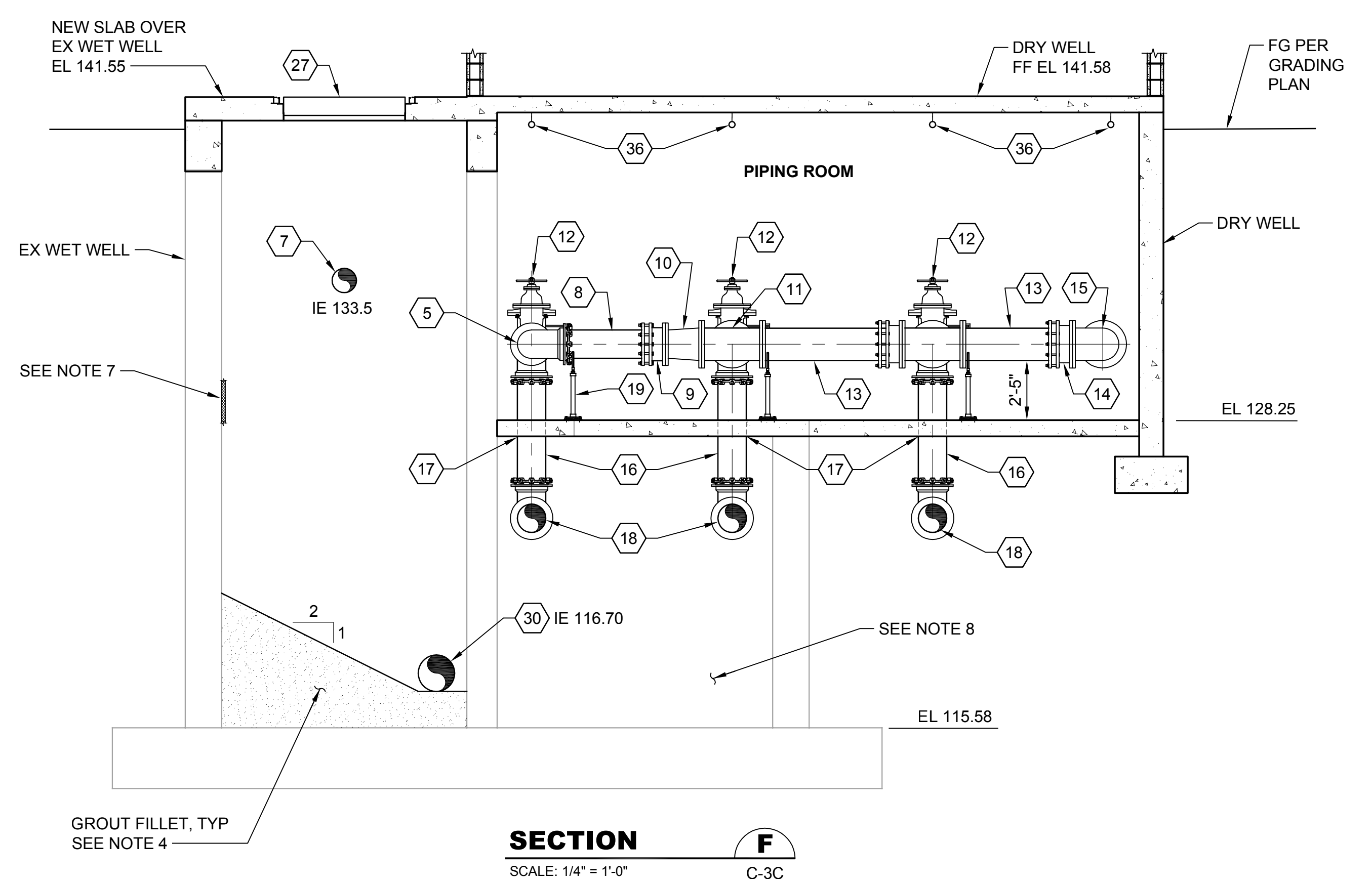

**SECTION F**  
SCALE: 1/4" = 1'-0"  
C-3C

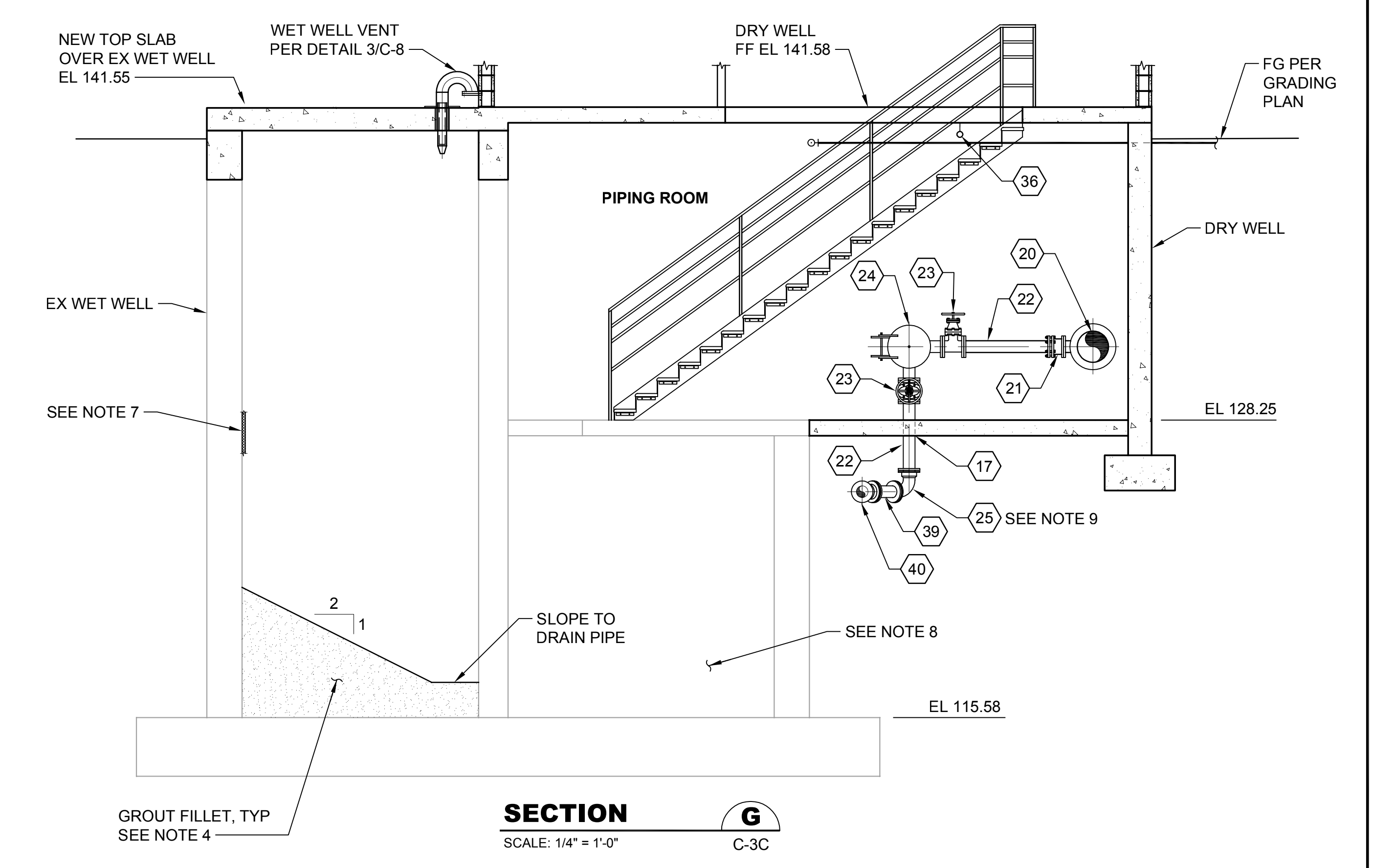

**SECTION G**  
SCALE: 1/4" = 1'-0"  
C-3C

**NOTES:**

- ALL DUCTILE IRON PIPE AND FITTINGS SHALL BE CLASS 52 AND LINED WITH PROTECTO 401.
- ALL BOLTED CONNECTIONS IN THE WET WELL SHALL BE CONSTRUCTED WITH DOUBLE 316L SST NUTS.
- ALL BELL AND SPIGOT, MECHANICAL, AND PLAIN END JOINTS SHALL BE RESTRAINED.
- ADJUST DIMENSIONS OF FLAT AREA AND GROUTED FILLETS AROUND PUMPS, DISCHARGE ELBOW, PRESSURE SENSING LEVEL PROBE, AND LEVEL FLOATS TO PROVIDE 6 INCHES CLEARANCE.
- COORDINATE HATCH LOCATION WITH PUMP MANUFACTURER AND GUIDE RAILS TO AVOID CONFLICTS.
- ALL ACCESS HATCHES SHALL HAVE A SAFETY GRATE BY HATCH MANUFACTURER UNLESS NOTED OTHERWISE. SAFETY GRATE SWING SHALL BE THE SAME AS THE HATCH DOOR.
- CLEAN INTERIOR OF WET WELL AND COAT WITH INTERIOR COATING SYSTEM C PER SECTION 099600 OF THE SPECIFICATIONS. INSTALL FILLETS PRIOR TO COATING THE WET WELL.
- COMPLETELY FILL LOWER LEVEL WITH COMPACTED SAND OR CDF FOLLOWING INSTALLATION AND TESTING OF NEW PIPE.
- ROTATE BEND 45° CLOCKWISE.

**PUMP STATION COMPONENTS**

- |   |   |
|---|---|
| 1 36" x 24" WET WELL, SEE STRUCTURAL DRAWINGS   | 23 6" GV WITH HANDWHEEL, FL x FL, TYP OF 2  |
| 2 SUBMERSIBLE PUMP  | 24 20" PIG LAUNCH, PER DETAIL 5/C-8   |
| 3 84" x 60" DOUBLE LEAF ALUM ACCESS HATCH, H-30 RATED, SEE NOTES 5 AND 6, DWG C-7C, AND STRUCTURAL DWGS | 25 6" DI 90° BEND, MJ x MJ, ROTATE PER PLAN VIEW  |
| 4 14" DI SPOOL, FL x PE, LENGTH AS REQUIRED   | 26 PIPE SUPPORT TYPE 2, PER DETAIL 3/C-7, TYP   |
| 5 14" DI 90° BEND, FL x MJ  | 27 72" x 48" DOUBLE LEAF ALUMINUM ACCESS HATCH, H-30 RATED, TYP OF 2, SEE NOTES 5 AND 6 |
| 6 12" DUCKBILL TYPE CHECK VALVE, FL CONNECTION  | 28 18" INSIDE DROP CONNECTION, PER DETAIL 4/C-8   |
| 7 12" OVERFLOW, PER DETAIL 4/C-8  | 29 18" GV W/ VALVE BOX, MJ x MJ   |
| 8 14" DI SPOOL, FL x PE, LENGTH AS REQUIRED   | 30 12" DI SPOOL, PE x PE  |
| 9 14" RESTRAINED FLANGE COUPLING ADAPTOR  | 31 WALL PENETRATION TYPE 1, PER DETAIL 7/C-7, CORE DRILL HOLE, MATCH PIE SIZE           |
| 10 16" x 14" DI REDUCER, FL x FL  | 32 6" GV WITH VALVE BOX, FL x FL  |
| 11 16" x 14" DI TEE, FL x FL, TYP OF 2  | 33 6" DI TEE, FL x FL   |
| 12 14" GV WITH HANDWHEEL, FL X FL   | 34 6" DUCKBILL TYPE CHECK VALVE, FL CONNECTION IE 126.00                                |
| 13 16" DI SPOOL, FL x PE, LENGTH AS REQUIRED  | 35 14" RESTRAINED FLANGE COUPLING ADAPTER, FL x MJ                                      |
| 14 16" RESTRAINED FLANGE COUPLING ADAPTOR, TYP OF 2   | 36 PICK POINT, SEE DRAWING C-7C AND STRUCTURAL DRAWINGS FOR LOCATIONS AND DETAILS       |
| 15 16" DI 90° BEND, FL X FL   | 37 6" BACKFLUSH PIPE, PER DETAIL 1/C-7  |
| 16 14" DI SPOOL, PE x PE, LENGTH AS REQUIRED  | 38 6" DI 90° BEND, FL x FL  |
| 17 WALL/FLOOR PENETRATION TYPE 2, PER DETAIL 8/C-7  | 39 6" DI SPOOL, PE x PE LENGTH AS REQUIRED  |
| 18 14" DI 90° BEND, MJ x MJ   | 40 6" DI 45° BEND, MJ x MJ  |
| 19 PIPE SUPPORT TYPE 1, PER DETAIL 2/C-7, TYP OF 3  | 41 INTERMEDIATE GUIDE RAIL SUPPORTS, SEE STRUCTURAL DRAWINGS                            |
| 20 16" x 6" DI TEE, FL x FL   |   |
| 21 6" RESTRAINED FLANGE COUPLING ADAPTOR  |   |
| 22 6" DI SPOOL, FL x PE, LENGTH AS REQUIRED   |   |

**Call 48 Hours Before You Dig**  
1-800-424-5555  
UNDERGROUND SERVICE

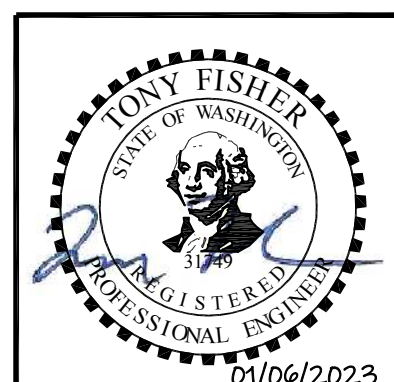

Path: S:\Cadd\Kitsap County\21-10530 Silverdale Conveyance-PS 4 Uprgr\Design\Drawings\21-10530\_C-6C\_PIPING.dwg, Jan 06, 2023, 03:44:33pm, CAD User: J.Lira, Xref Filename: I:\21-10530-PS4\_TB\1\Fisher\21-10530-PS4\_Ext\_Bldg\21-10530-PS4\_Prop\_Bldg\21-10530-PS4\_Prop\_Mech\21-10530-PS4\_Prop\_Mech.dwg

		<b>BHC Consultants, LLC</b> 1601 Fifth Avenue, Suite 500 Seattle, Washington 98101 206.505.3400 206.505.3406 (fax) www.bhcconsultants.com	Designed: T. Fisher, P.E. Drawn: P. Simon Checked: R. Dorn, P.E.	Scale: 1/4" = 1'-0" One Inch at Full Scale If Not One Inch Scale Accordingly		<b>Kitsap County Public Works</b> 614 Division Street, MS 26 Port Orchard, WA 98366	<b>SILVERDALE CONVEYANCE SYSTEM AND PUMP STATION 4 UPGRADES SCHEDULE C CONTROL BUILDING PIPING ROOM AND WET WELL SECTIONS 3 OF 3</b>	Drawing: <b>C-6C</b> Sheet: <b>44</b> of <b>117</b> File: P21-10530_C-6C Date: January 2023
--	--	--	--	---	--	---	--	--

Path: S:\Cadd\Kitsap County\21-10530 Silverdale Conveyance-PS 4 Uprgr\Design\Drawings\21-10530\_C-7C\_Pick.dwg, Jan 06, 2023, 03:58:37pm CAD User: JLiira  
 Xref Filename: I:\21-10530-PS4\_TB\Fisher\21-10530-PS4\_Ext\_Bldg\21-10530-PS4\_Prop\_Bldg\21-10530-PS4\_Prop\_Mech\21-10530-PS4\_Prop\_Mech.dwg

NORTH

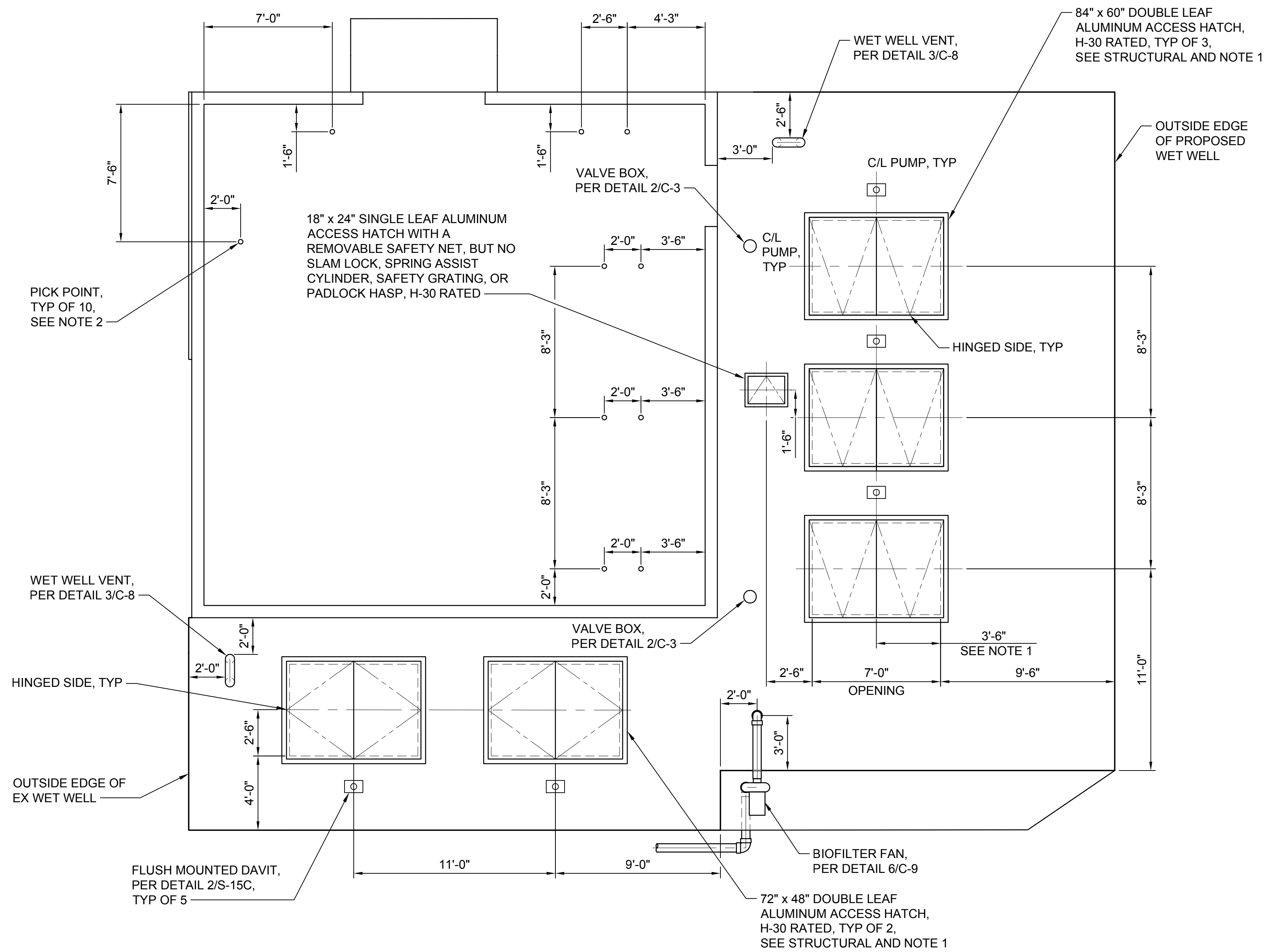

- NOTES:**
- COORDINATE HATCH LOCATION WITH PUMP MANUFACTURER AND GUIDE RAILS TO AVOID CONFLICTS. ALL ACCESS HATCHES SHALL HAVE A SAFETY GRATE BY HATCH MANUFACTURER UNLESS NOTED OTHERWISE. SAFETY GRATE SWING SHALL BE THE SAME AS THE HATCH DOOR.
  - LOCATE PICK POINTS ON BOTTOM SIDE OF SLAB OVER PIPING ROOM, SEE STRUCTURAL FOR PICK POINT DETAILS.

**WET WELL/DRY WELL TOP SLAB AND ACCESS HATCH LAYOUT**  
**DETAIL 1**  
 SCALE: 1/4" = 1'-0" C-3C

NORTH

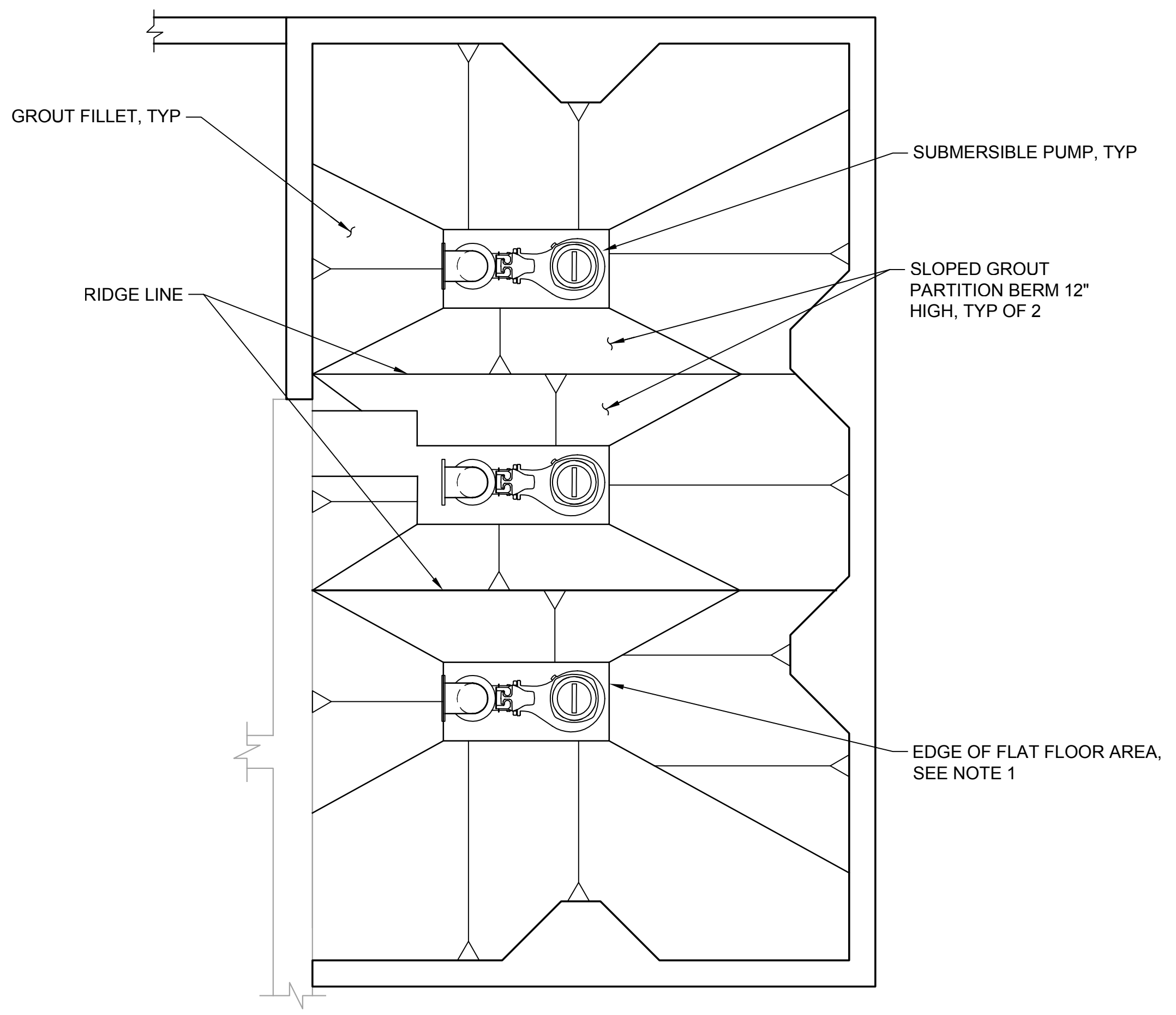

- NOTES:**
- ADJUST DIMENSIONS OF FLAT AREA AND GROUTED FILLETS AROUND PUMPS, DISCHARGE ELBOW, PRESSURE SENSING LEVEL PROBE, AND LEVEL FLOATS TO PROVIDE 6 INCHES CLEARANCE.
  - SLOPE GROUT FILLETS AT 1V:2H MINIMUM.

**WET WELL CHANNELING**  
**DETAIL 2**  
 SCALE: 1/4" = 1'-0" C-3C

**Call 48 Hours Before You Dig**  
 1-800-424-5555  
 UNDERGROUND SERVICE

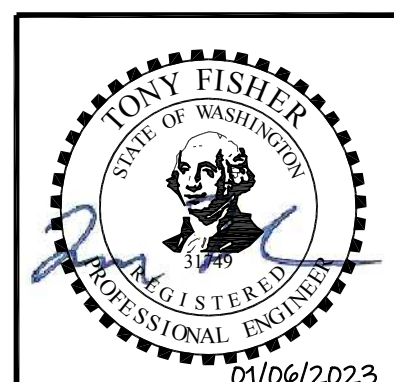

No.	Revision	Date	By	App'd
	ISSUED FOR BID	01-2023	TF	RAD

**bhc** CONSULTANTS  
 BHC Consultants, LLC  
 1601 Fifth Avenue, Suite 500  
 Seattle, Washington 98101  
 206.505.3400  
 206.505.3406 (fax)  
 www.bhcconsultants.com

Designed: T. Fisher, P.E.  
 Drawn: P. Simon  
 Checked: R. Dorn, P.E.

Scale:  
 1/4" = 1'-0"  
 One Inch at Full Scale  
 If Not One Inch Scale Accordingly



**Kitsap County Public Works**  
 614 Division Street, MS 26  
 Port Orchard, WA 98366

**SILVERDALE CONVEYANCE SYSTEM AND PUMP STATION 4 UPGRADES**  
 SCHEDULE C  
**WET WELL/DRY WELL TOP SLAB AND CHANNELING PLANS**

Drawing: **C-7C**  
 Sheet: **45** of **117**  
 File: P21-10530\_C-7C  
 Date: January 2023

Path: S:\CAD\Kitsap County\21-10530 Silverdale Conveyance\PS 4 Upgrd\Design\Drawings\21-10530\_C-8C\_PICP.dwg, Jan 06, 2023, 05:58:20pm CAD User: solace.  
 Xref Filename: I:\Fisher\1\21-10530\_PSA\_Ext\_Topo\1\21-10530\_PSA\_Prop\PS4\_Prop\HMA\1\Drawn\Palmer.dwg

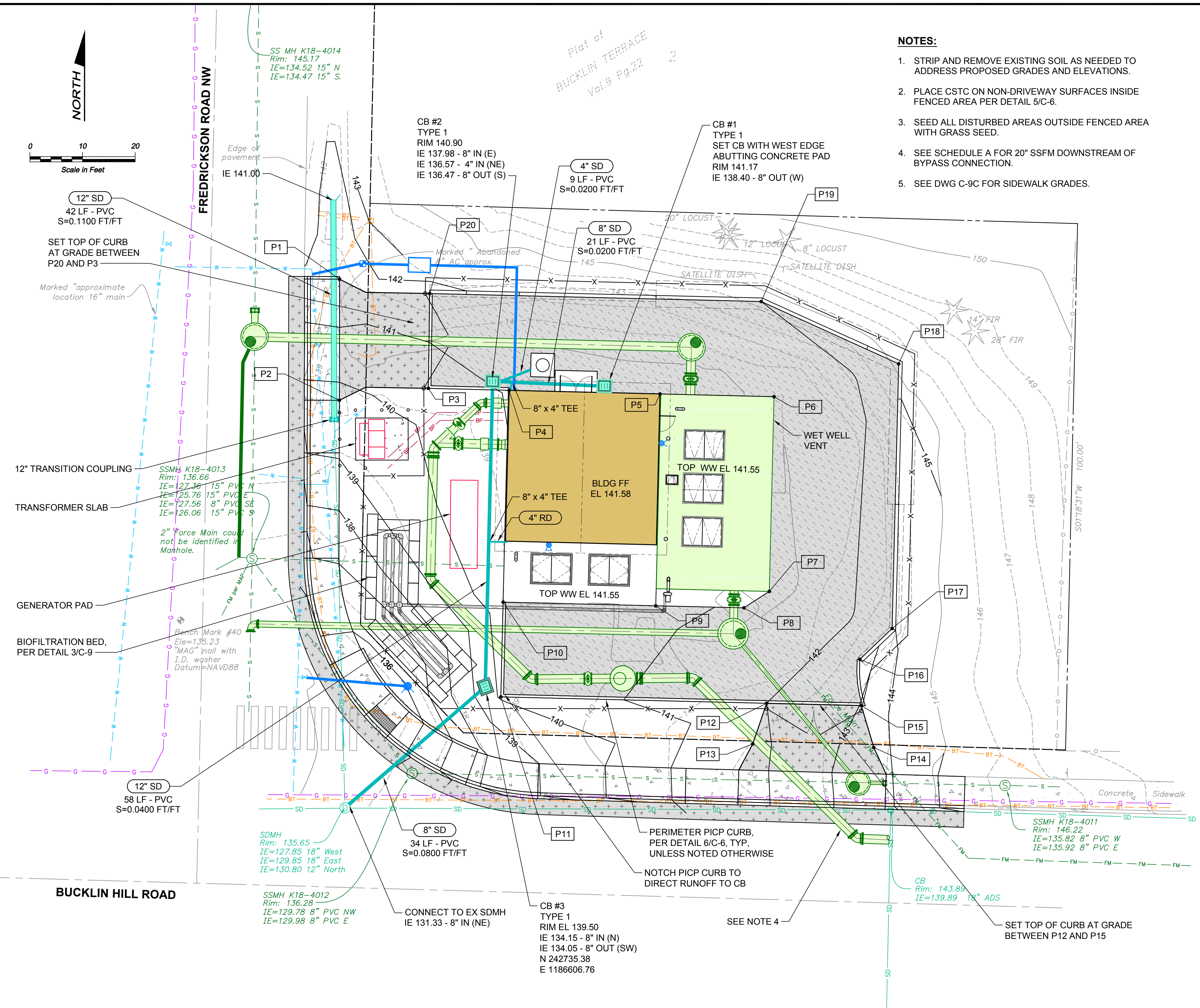

**NOTES:**

- 1. STRIP AND REMOVE EXISTING SOIL AS NEEDED TO ADDRESS PROPOSED GRADES AND ELEVATIONS.
- 2. PLACE CSTC ON NON-DRIVEWAY SURFACES INSIDE FENCED AREA PER DETAIL 5/C-6.
- 3. SEED ALL DISTURBED AREAS OUTSIDE FENCED AREA WITH GRASS SEED.
- 4. SEE SCHEDULE A FOR 20" SSSFM DOWNSTREAM OF BYPASS CONNECTION.
- 5. SEE DWG C-9C FOR SIDEWALK GRADES.

**COORDINATE CONTROL**

PT #	NORTHING	EASTING	ELEVATION	DESCRIPTION
P1	242817.64	1186579.18	142.0±1	HMA
P2	242794.64	1186579.16	140.10	HMA
P3	242796.91	1186596.06	140.00	HMA AT PICP CURB
P4	242796.53	1186611.40	141.08	PICP AT BUILDING CORNER
P5	242795.84	1186640.06	141.28	PICP AT BUILDING CORNER
P6	242795.32	1186661.72	141.43	PICP AT WET WELL CORNER
P7	242758.33	1186660.83	141.10	PICP AT WET WELL CORNER
P8	242755.21	1186656.01	141.05	PICP AT SIDEWALK CORNER
P9	242755.60	1186639.26	140.90	PICP AT WET WELL CORNER
P10	242756.30	1186610.26	140.63	PICP AT WET WELL CORNER
P11	242738.30	1186609.83	140.14	TOP OF CURB RESTRAINT
P12	242737.08	1186660.32	142.00	HMA AT PICP CURB
P13	242729.36	1186657.68	141.82	HMA
P14	242728.69	1186680.67	143.50	HMA
P15	242736.65	1186678.31	143.02	HMA AT PICP CURB
P16	242745.43	1186678.02	142.40	PICP AT WALL
P17	242751.28	1186684.16	142.40	PICP AT WALL
P18	242801.56	1186685.40	142.30	PICP AT WALL
P19	242813.38	1186659.32	142.00	PICP AT WALL
P20	242814.91	1186596.31	141.14	HMA/PICP AT WALL

\* MATCH EXISTING GROUND ELEVATION

**COORDINATE CONTROL NOTES:**

- 1. SEE DWGS D-1C C-1C, C-2C, AND C-9C AND C-1C FOR ADDITIONAL COORDINATE POINTS.

**Call 48 Hours Before You Dig**

**1-800-424-5555**  
UNDERGROUND SERVICE



No.	Revision	Date	By	App'd

**bhc CONSULTANTS**  
 BHC Consultants, LLC  
 1601 Fifth Avenue, Suite 500  
 Seattle, Washington 98101  
 206.505.3400  
 206.505.3406 (fax)  
 www.bhcconsultants.com

Designed: T. Fisher, P.E.  
 Drawn: P. Simon  
 Checked: R. Dorn, P.E.

Scale: 1" = 10'-0"  
 One Inch at Full Scale  
 If Not One Inch Scale Accordingly



**Kitsap County Public Works**  
 614 Division Street, MS 26  
 Port Orchard, WA 98366

**SILVERDALE CONVEYANCE SYSTEM AND PUMP STATION 4 UPGRADES SCHEDULE C**

**GRADING AND DRAINAGE PLAN**

Drawing:	<b>C-8C</b>
Sheet:	<b>46 of 117</b>
File:	P21-10530_C8C
Date:	January 2023

Path: S:\Cadd\Kitsap County\21-10530 Silverdale Conveyance-PS 4 Uprtg\Design\Drawings\21-10530\_C-9C\_P1.dwg, Date: Jan 06, 2023, 06:06:02pm, CAD User: sfolice, Xref Filename: I:\Fisher\1\21-10530\_PSA\_1\21-10530\_PSA\_1.dwg, Ex Topo Site\1\21-10530\_PSA\_1\21-10530\_PSA\_1.dwg, Palmiter

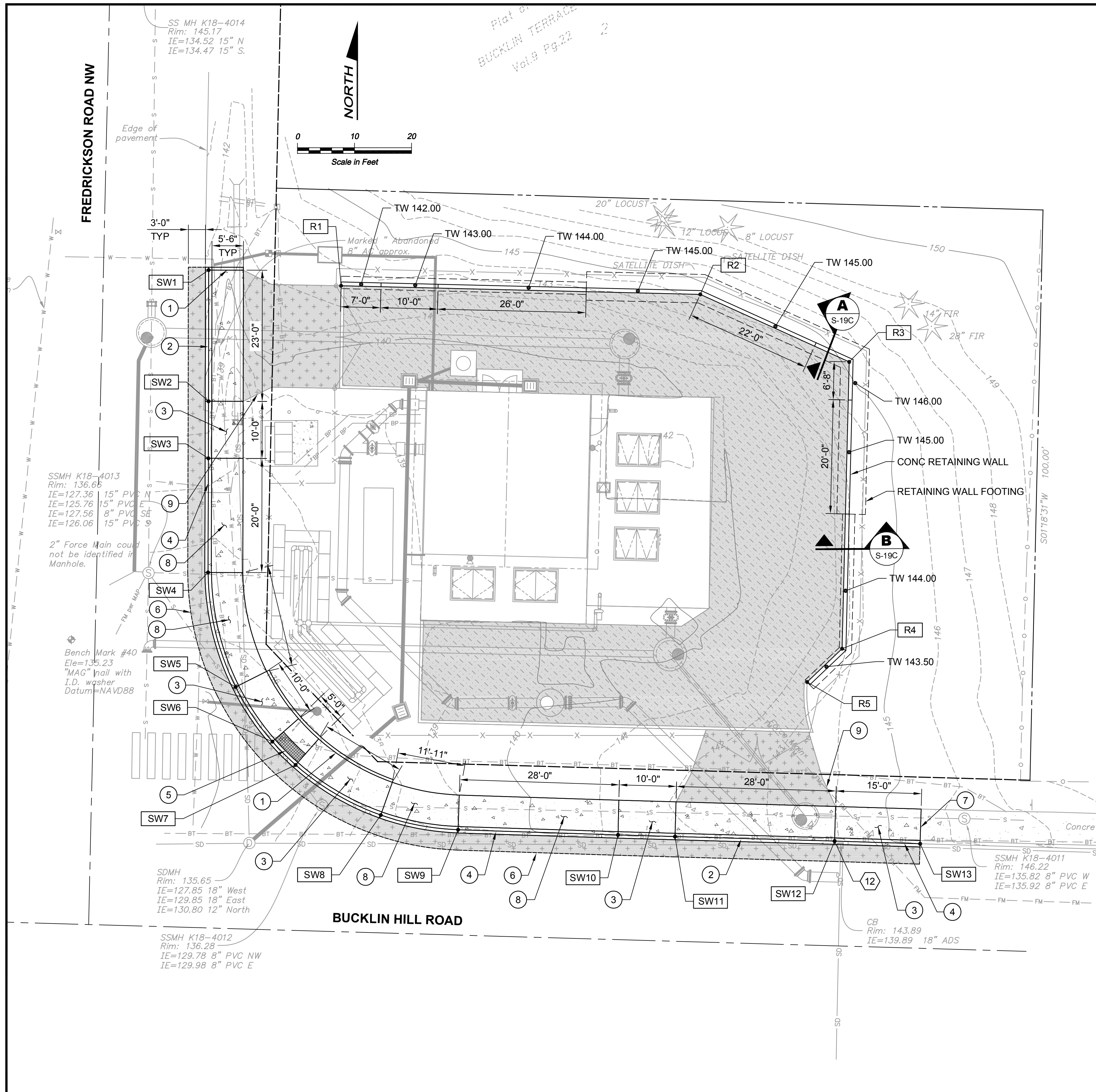

**NOTES:**

- SEE DRAWING S-19C FOR RETAINING WALL STRUCTURAL DETAILS.
- ALL SIDEWALK, LANDINGS, AND REMAPS SHALL BE BROOM FINISHED.
- CURB RAMP SHALL BE A PARALLEL TYPE A CURB RAMP PER WSDOT STANDARD PLAN DETAIL F-40.
- GRADE SOIL BEHIND SIDEWALK, PEDESTRIAN RAMP, AND LANDING PER DRAWING C-8C.
- CROSS SLOPE FROM BACK OF SIDEWALK TO FACE OF CURB SHALL NOT EXCEED 2%.

**CONSTRUCTION NOTES:**

- CEMENT CONCRETE PEDESTRIAN CURB PER WSDOT STD DETAIL F-10.
- DEPRESSED CURB AND GUTTER PER WSDOT STD DETAIL F-10. PROVIDE CONTRACTION JOINTS IN CURB, GUTTER, AND ACCESS DRIVEWAY, EVENLY SPACED, 4'-0" MIN ON CENTER.
- PROVIDE CONTRACTION JOINT(S) ON RAMPS AT 5'-0" ON CENTER.
- CEMENT CONCRETE TRAFFIC CURB AND GUTTER PER WSDOT STD DETAIL F-10. PROVIDE CONTRACTION JOINTS IN CURB AND GUTTER EVENLY SPACED, 4'-0" MIN ON CENTER.
- DETECTABLE WARNING SURFACE PER WSDOT STD DETAIL F-45. LONGITUDINAL SLOPE SHALL NOT EXCEED 2%.
- SAWCUT EXISTING PAVEMENT, COMPACT PAVEMENT AGGREGATE BASE AND PLACE HMA IN COMPACTED LIFTS TO MATCH DEPTH OF EXISTING PAVEMENT.
- SAWCUT EXISTING CURB, GUTTER, AND SIDEWALK TO NEAREST FULL JOINT AND PROVIDE CLEAN EDGE AND NEW EXPANSION JOINT.
- CEMENT CONCRETE SIDEWALK PER WSDOT STD DETAIL F30.10. PROVIDE CONTRACTION JOINTS IN SIDEWALK, EVENLY SPACED, 4'-0" MIN ON CENTER.
- URBAN RESIDENTIAL APPROACH PER KITSAP COUNTY STANDARD DETAIL FIGURE 4-3.

**SIDEWALK AND CURB TABLE**

ITEM #	DESCRIPTION	FLOWLINE NORTHING	FLOWLINE EASTING	FLOWLINE ELEVATION	CURB HEIGHT	BACK SIDEWALK ELEVATION
SW1	ACCESS DWY	242817.66	1186573.10	141.79	0.5	141.88
SW2	ACCESS DWY	242794.66	1186573.07	139.58	0.0	139.67
SW3*	RAMP	242784.65	1186573.04	138.52	0.5	139.11
SW4	SIDEWALK PC	242764.65	1186572.99	136.49	0.5	137.08
SW5	RAMP	242744.56	1186577.82	135.13	0.5	135.72
SW6	LANDING	242734.99	1186584.27	135.25	0.0	135.35
SW7	LANDING	242730.90	1186588.34	135.35	0.0	135.44
SW8	RAMP	242722.11	1186603.27	137.26	0.5	137.79
SW9	SIDEWALK PT	242719.54	1186616.83	138.46	0.5	138.99
SW10	RAMP	242718.63	1186644.87	140.70	0.5	141.23
SW11	ACCESS DWY	242718.35	1186654.86	141.50	0.0	141.53
SW12	ACCESS DWY	242717.54	1186682.84	143.80	0.0	143.86
SW13**	RAMP	242717.08	1186697.84	145.04	0.5	145.60

\* PROVIDE CONTRACTION JOINT IN RAMP EQUALLY SPACED AT 5'-0" OC.  
 \*\* MATCH EXISTING ELEVATIONS AT EXISTING CURB AND SIDEWALK TIE-INS.

**RETAINING WALL - COORDINATE CONTROL**

PT #	NORTHING	EASTING	TW EL	BW EL
R1	242814.91	1186596.31	142.00	141.14
R2	242813.39	1186659.29	145.50	141.27
R3	242801.56	1186685.40	146.00	141.40
R4	242751.28	1186684.16	144.00	141.74
R5	242745.43	1186678.02	144.00	142.00

**Call 48 Hours Before You Dig**  
 1-800-424-5555  
 UNDERGROUND SERVICE

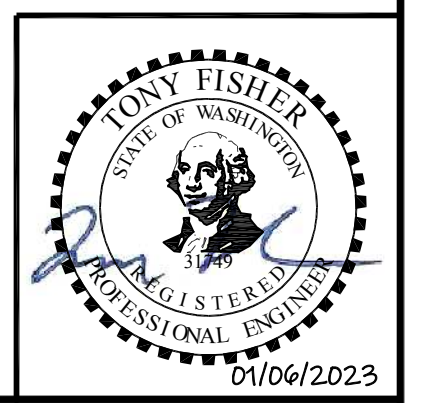

**bhc**  
 CONSULTANTS

**BHC Consultants, LLC**  
 1601 Fifth Avenue, Suite 500  
 Seattle, Washington 98101  
 206.505.3400  
 206.505.3406 (fax)  
 www.bhcconsultants.com

Designed: T. Fisher, P.E.  
 Drawn: P. Simon  
 Checked: R. Dorn, P.E.

Scale:  
 1" = 10'-0"  
 One Inch at Full Scale  
 If Not One Inch Scale Accordingly

**Kitsap County Public Works**  
 614 Division Street, MS 26  
 Port Orchard, WA 98366

**SILVERDALE CONVEYANCE SYSTEM AND PUMP STATION 4 UPGRADES SCHEDULE C**

**RETAINING WALL AND SIDEWALK PLAN**

Drawing: **C-9C**  
 Sheet: **47** of **117**  
 File: P21-10530\_C-9C  
 Date: January 2023

**ARCHITECTURAL GENERAL NOTES**

- DRAWINGS ARE IN PART DIAGRAMMATIC AND DO NOT NECESSARILY SHOW COMPLETE DETAILS OF CONSTRUCTION, WORK, OR MATERIALS, PERFORMANCE OR INSTALLATION. DRAWINGS DO NOT NECESSARILY SHOW HOW CONSTRUCTION DETAILS, OTHER ITEMS OR WORK AND EQUIPMENT MAY AFFECT A PARTICULAR INSTALLATION.
- FEATURES NOT FULLY SHOWN ON PLANS OR DETAILS ARE TO BE PROVIDED AS INDICATED FOR SIMILAR CONDITIONS.
- THE OWNER SHALL BE NOTIFIED OF ANY VARIATION FROM THE DIMENSIONS AND/OR CONDITIONS SHOWN ON THESE DOCUMENTS. ANY SUCH VARIATIONS SHALL BE APPROVED BY THE OWNER PRIOR TO PROCEEDING WITH THE WORK, OR THE CONTRACTOR SHALL ACCEPT FULL RESPONSIBILITY FOR COST TO RECTIFY THE SAME.
- ALL DIMENSIONS TO WALLS SHOWN ON DRAWINGS ARE TAKEN FROM FACE OF BLOCK.
- DO NOT SCALE DRAWINGS. WRITTEN DIMENSIONS ON THE DRAWINGS SHALL HAVE PRECEDENCE OVER SCALED DIMENSIONS.
- VERIFY DIMENSIONS, ROUGH OPENING SIZES SHOWN FOR DOORS, WINDOWS AND OTHER PENETRATIONS AGAINST REQUIREMENTS OF SPECIFIED PRODUCTS, CONDITIONS, ELEVATIONS, ETC. PERTAINING TO WORK BEFORE PROCEEDING.
- PROVIDE ALL SUB-FRAMING AS REQUIRED TO RECEIVE WORK BY OTHERS.
- PROVIDE GALVANIC ISOLATION BETWEEN DISSIMILAR METALS.
- ALL OPENINGS SHALL BE CAULKED, SEALED, OR WEATHER STRIPPED.
- NOT ALL ELEMENTS ARE SHOWN ON ARCHITECTURAL DRAWINGS. SEE STRUCTURAL, MECHANICAL AND ELECTRICAL DRAWINGS.
- ALL CLEAR DIMENSIONS ARE TO BE EXACTLY WITHIN 1/8" FULL HEIGHT AND WIDTH OF WALLS. CONTRACTOR SHALL NOT ADJUST ANY DIMENSIONS MARKED "CLEAR" OR "CLR" WITHOUT WRITTEN INSTRUCTIONS FROM THE OWNER.
- CONTRACTOR SHALL ADHERE TO ALL CODES, RULES AND REGULATIONS GOVERNING CONSTRUCTION BUILDING ACCESS AND THE USE OF FACILITIES AS SET BY THE AUTHORITY HAVING JURISDICTION.

**CODE NOTES**

JURISDICTION: KITSAP COUNTY DEPARTMENT OF COMMUNITY DEVELOPMENT  
 BUILDING: 2018 INTERNATIONAL BUILDING CODE (IBC), WITH KITSAP COUNTY AMENDMENTS  
 FIRE PROTECTION: 2018 INTERNATIONAL FIRE CODE (IFC), WITH WASHINGTON STATE AMENDMENTS  
 HYDRANTS, FIRE EXTINGUISHERS, COMBUSTIBLE GAS DETECTION SYSTEM PER NFPA 820, 2020 EDITION  
 ACCESSIBILITY: 2018 IBC CH. 11 WITH WASHINGTON STATE WAC 51-50 AMENDMENTS AND ICC A117.1-2009

PUMP STATION BUILDING

BUILDING TYPE: V-B  
 OCCUPANCY TYPE: U (2018 IBC 312)  
 OCCUPANT LOAD: 49 (2018 IBC TABLE 1004.5)  
 FIRE SPRINKLERS: REQUIRED: NO (2018 IBC 903.2)  
 PROVIDED: NO  
 FIRE ALARM: REQUIRED: NO (2018 IBC 907.2.2)  
 PROVIDED: NO  
 BUILDING HEIGHT (2018 IBC TABLE 504.3, 504.4)  
 A. ALLOWABLE: 1 STORIES/40 FT  
 B. PROPOSED: 1 STORY/ 16 FT (FROM FINISH GRADE)  
 BUILDING AREA (2018 IBC TABLE 506.2)  
 A. ALLOWABLE: 5,500 SF  
 B. PROPOSED:

EXITING

EXIT ACCESS TRAVEL DISTANCE:  
 LESS THAN 300 FT OF TRAVEL DISTANCE  
 (2018 IBC TABLE 1017.2)  
 COMMON PATH EGRESS TRAVEL:  
 LESS THAN 100 FT  
 (2018 IBC TABLE 1006.2.1)  
 MIN NUMBER OF EXITS OR EXIT ACCESS PER ROOM:  
 1 (2018 IBC TABLE 1006.3.3)

**WASHINGTON STATE ENERGY CODE**

USE OF EXCEPTION C OF THE TABLE C402.1.3 OF THE 2018 WASHINGTON STATE ENERGY CODE ALLOWS EXEMPTION FOR THE REQUIREMENT OF CONTINUOUS INSULATION.

EXCEPTION C:

- AT LEAST 50 PERCENT OF CORES MUST BE FILLED WITH VERMICULITE OR EQUIVALENT FILL INSULATION; AND
- THE BUILDING THERMAL ENVELOPE ENCLOSES ONE OR MORE OF THE FOLLOWING USES: WAREHOUSE (STORAGE AND RETAIL), GYMNASIUM, AUDITORIUM, CHURCH CHAPEL, ARENA, KENNEL, MANUFACTURING PLANT, INDOOR SWIMMING POOL, PUMP STATION, WATER AND WASTE WATER TREATMENT FACILITY, STORAGE FACILITY, STORAGE AREA, MOTOR VEHICLE SERVICE FACILITY.

ALL INSULATION MATERIALS SHALL BE INSTALLED ACCORDING TO THE MANUFACTURER'S INSTRUCTIONS TO ACHIEVE PROPER DENSITIES, MAINTAIN CLEARANCES AND MAINTAIN UNIFORM R-VALUES TO THE MAXIMUM EXTENT POSSIBLE, INSULATION SHALL EXTEND OVER THE FULL COMPONENT AREA TO THE INTENDED R-VALUE.

EXTERIOR JOINTS AROUND WINDOWS AND DOOR FRAMES, OPENINGS BETWEEN WALLS AND FOUNDATION, BETWEEN WALLS AND ROOF AND WALL PANELS; OPENINGS AT PENETRATIONS OF UTILITY SERVICES THROUGH WALLS, FLOORS AND ROOFS; AND ALL OTHER OPENINGS IN THE BUILDING ENVELOPE SHALL BE SEALED, CAULKED, GASKETED AND/OR WEATHER STRIPPED TO LIMIT AIR LEAKAGE. 'BUILDING ENVELOPE' MEANS ALL BUILDING ELEMENTS SEPARATING CONDITIONED FROM UNCONDITIONED SPACES.

DOORS AND OPERABLE GLAZING SEPARATING CONDITIONED FROM UNCONDITIONED SPACE SHALL BE WEATHER STRIPPED; FIXED WINDOWS SHALL BE TIGHT FITTING WITH GLASS RETAINED BY STOPS WITH SEALANT OR CAULKING ALL AROUND.

**Call 48 Hours Before You Dig**

**1-800-424-5555**  
 UNDERGROUND SERVICE

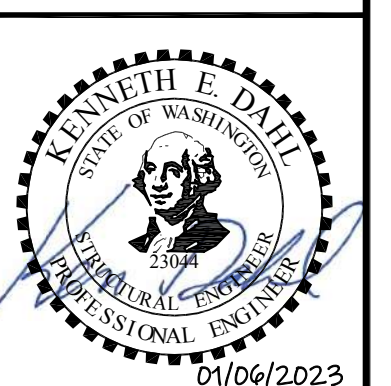

**BHC Consultants, LLC**  
 1601 Fifth Avenue, Suite 500  
 Seattle, Washington 98101  
 206.505.3400  
 206.505.3406 (fax)  
 www.bhcconsultants.com

Designed: K. Dahl, P.E., S.E.  
 Drawn: A. Bradley  
 Checked: T. Fisher, P.E.

Scale:  
 N/A  
 One Inch at Full Scale  
 If Not One Inch Scale Accordingly



**Kitsap County Public Works**  
 614 Division Street, MS 26  
 Port Orchard, WA 98366

**SILVERDALE CONVEYANCE SYSTEM AND PUMP STATION 4 UPGRADES SCHEDULE C**

**CODE SUMMARY**

Drawing: **A-1C**  
 Sheet: **48** of **117**  
 File: P21-10530\_A-1C  
 Date: January 2023



Path: S:\Cad\Kitsap County\21-10530 Silverdale Convey-PS-4 Upgr\Design\Drawings\21-10530\_A-2C\_PIPING.dwg, File: 21-10530\_A-2C\_PIPING.dwg, Date: 01/06/2023, Time: 08:58:48am, CAD User: JLFra, Xref File Name: 21-10530\_TB | Fisher | 21-10530-PS4\_Ext\_Bldg | 21-10530-PS4\_Prop\_Bldg | 21-10530-PS4\_Prop\_FIG | 21-10530-PS4\_Prop\_Grid | 21-10530-PS4\_Prop\_Mech | Palmatier |

NORTH

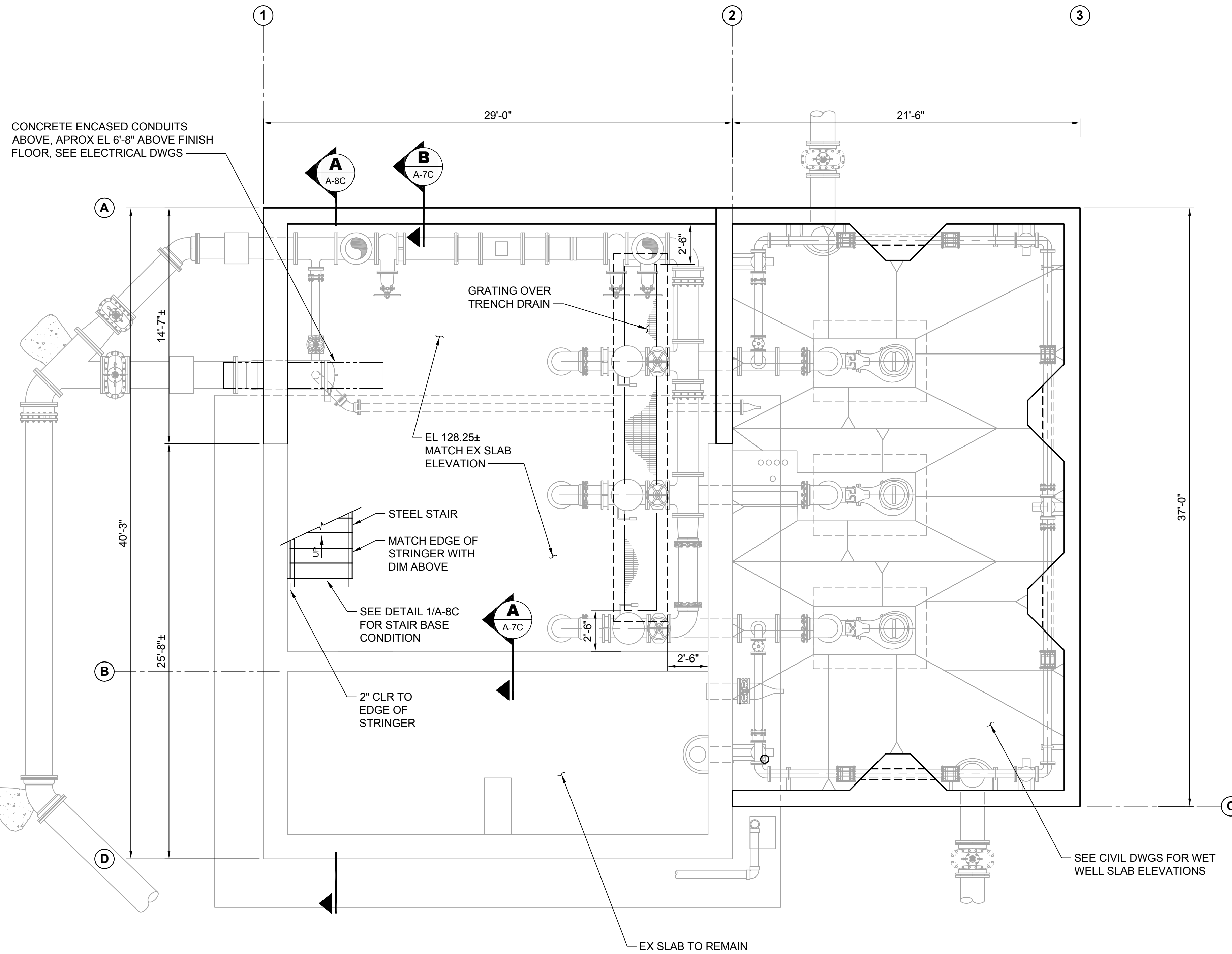

**Call 48 Hours Before You Dig**  
**1-800-424-5555**  
 UNDERGROUND SERVICE

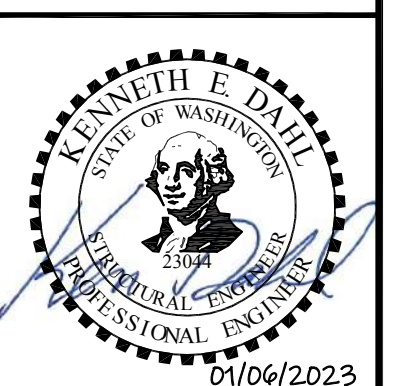

No.	Revision	Date	By	App'd
	ISSUED FOR BID	01-2023	TF	RAD



**BHC Consultants, LLC**  
 1601 Fifth Avenue, Suite 500  
 Seattle, Washington 98101  
 206.505.3400  
 206.505.3406 (fax)  
 www.bhcconsultants.com

Designed: K. Dahl, P.E., S.E.  
 Drawn: S. Olsoe  
 Checked: T. Fisher, P.E.

Scale:  
 1/4" = 1'-0"  
 One Inch at Full Scale  
 If Not One Inch Scale Accordingly



**Kitsap County Public Works**  
 614 Division Street, MS 26  
 Port Orchard, WA 98366

**SILVERDALE CONVEYANCE SYSTEM AND PUMP STATION 4 UPGRADES**  
**SCHEDULE C**  
**CONTROL BUILDING**  
**PIPING ROOM FLOOR PLAN**

Drawing: **A-2C**  
 Sheet: **49** of **117**  
 File: P21-10530\_A-2C  
 Date: January 2023

Path: S:\Cadd\Kitsap County\21-10530 Silverdale Conveyance PS 4 Upgr\Design\Drawings\A-3C Floor Plan.dwg, File Name: P21-10530\_A-3C Floor Plan.dwg, Date: 01/06/2023, 09:01:16am, CAD User: J.Lira, Xref File Name: 21-10530-PS4\_Ex Bldg | 21-10530-PS4\_Prop Mech | Dahl | 21-10530-PS4\_Prop Bldg | 21-10530-PS4\_Prop Elec | 21-10530-PS4\_Prop Grid | 21-10530-TB | Fisher | Palmalter |

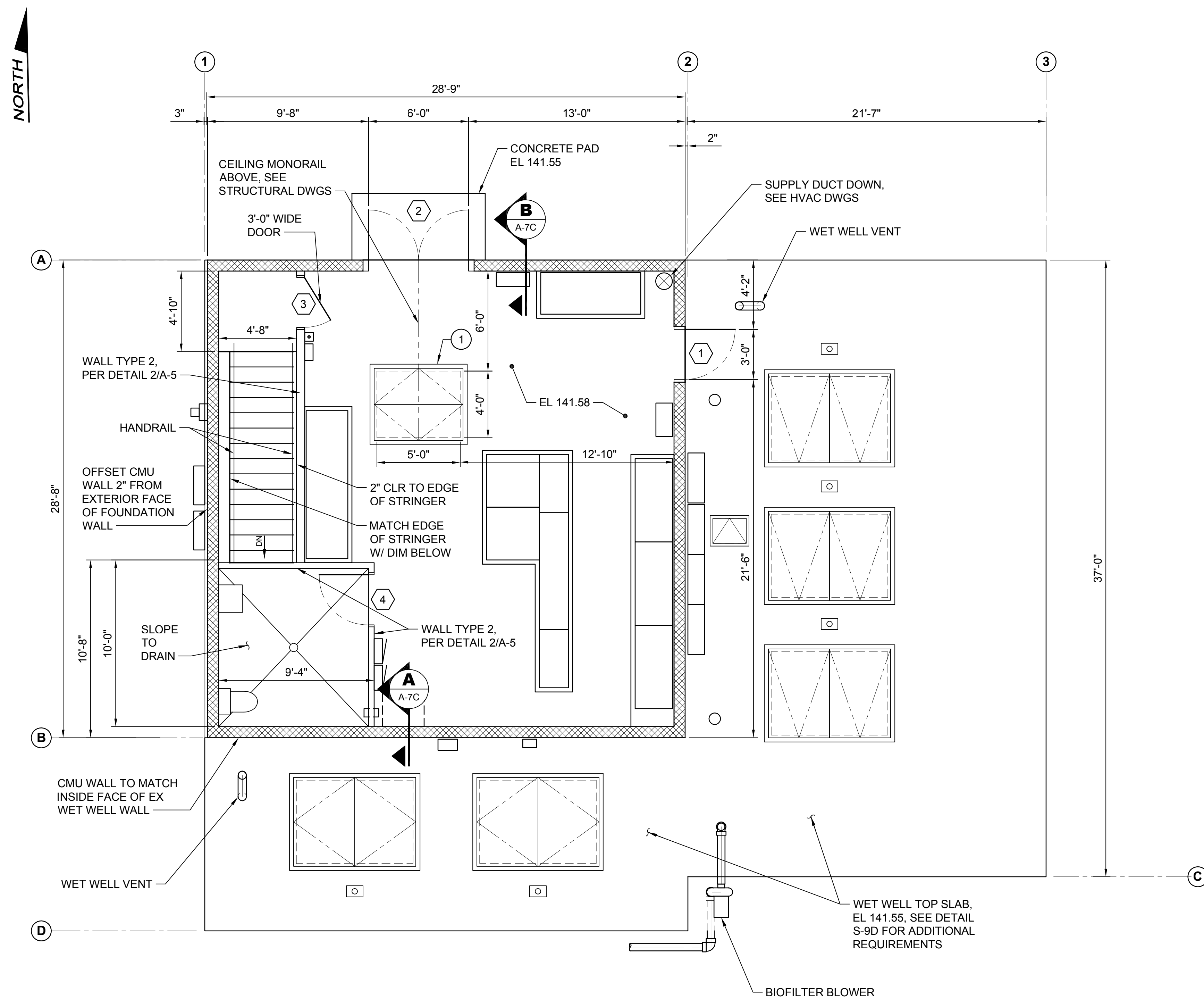

**NOTES:**

- 1. (#) SYMBOL REFERS TO THE DOOR SCHEDULE ON DWG A-10C.

**CONSTRUCTION NOTES:**

- 1. 48" x 60" DOUBLE LEAF ALUMINUM ACCESS HATCH, H-30 RATED.

**Call 48 Hours Before You Dig**

**1-800-424-5555**  
UNDERGROUND SERVICE



No.	Revision	Date	By	App'd
	ISSUED FOR BID	01-2023	TF	RAD

**bhc**  
CONSULTANTS

**BHC Consultants, LLC**  
1601 Fifth Avenue, Suite 500  
Seattle, Washington 98101  
206.505.3400  
206.505.3406 (fax)  
www.bhcconsultants.com

Designed: K. Dahl, P.E., S.E.  
Drawn: S. Olsoe  
Checked: T. Fisher, P.E.

Scale:  
1/4" = 1'-0"  
One Inch at Full Scale  
If Not One Inch Scale Accordingly



**Kitsap County Public Works**  
614 Division Street, MS 26  
Port Orchard, WA 98366

**SILVERDALE CONVEYANCE SYSTEM AND PUMP STATION 4 UPGRADES**  
SCHEDULE C  
**CONTROL BUILDING ELECTRICAL ROOM FLOOR PLAN**

Drawing: **A-3C**  
Sheet: **50** of **117**  
File: P21-10530\_A-3C  
Date: January 2023

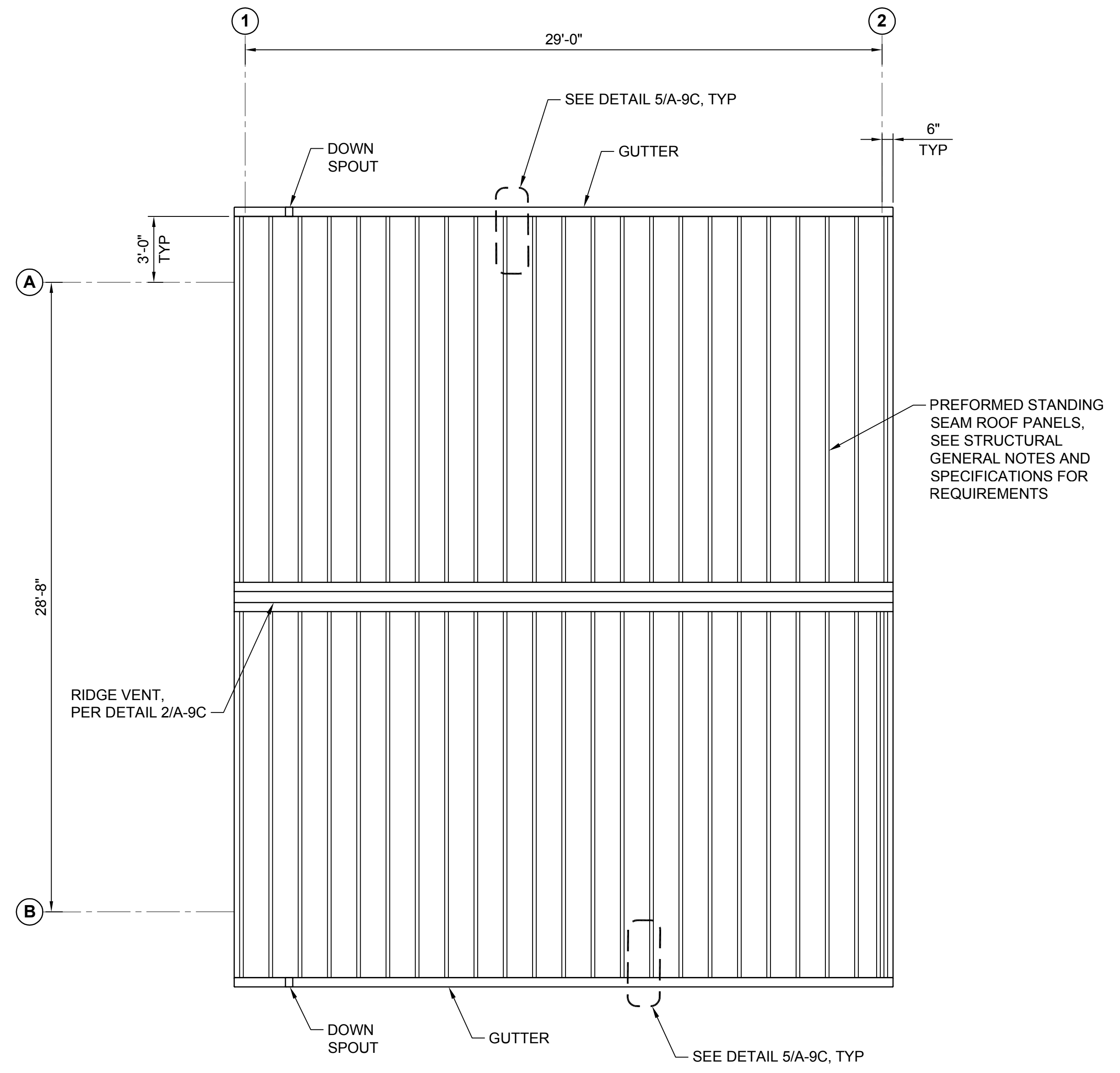

Path: S:\Cadd\Kitsap County\21-10530 Silverdale Conveyance-PS 4 Uprgt\Design\Drawings\21-10530-A-4C\_Prop.dwg, Jan 06, 2023, 09:02:47am CAD User: jllira  
 Xref Filename: X21-10530\_TB | Fisher | Dair | X21-10530-PS4\_Prop Bldg | X21-10530-PS4\_Prop Bldg | X21-10530-PS4\_Prop Roof | Palmater |

**Call 48 Hours Before You Dig**  
 1-800-424-5555  
 UNDERGROUND SERVICE

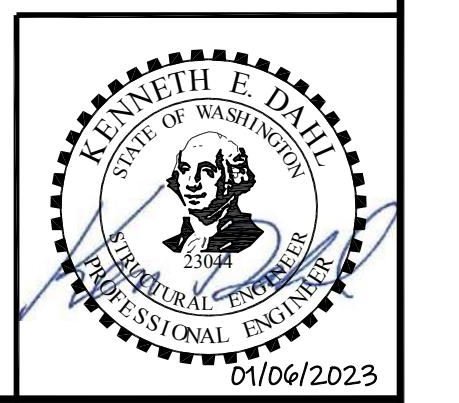

No.	Revision	Date	By	App'd
	ISSUED FOR BID	01-2023	TF	RAD

**bhc**  
**CONSULTANTS**  
**BHC Consultants, LLC**  
 1601 Fifth Avenue, Suite 500  
 Seattle, Washington 98101  
 206.505.3400  
 206.505.3406 (fax)  
 www.bhcconsultants.com

Designed: K. Dahl, P.E., S.E.  
 Drawn: A. Bradley  
 Checked: T. Fisher, P.E.

Scale:  
 1/4" = 1'-0"  
 One Inch at Full Scale  
 If Not One Inch Scale Accordingly



**Kitsap County Public Works**  
 614 Division Street, MS 26  
 Port Orchard, WA 98366

**SILVERDALE CONVEYANCE SYSTEM AND PUMP STATION 4 UPGRADES**  
**SCHEDULE C**  
**CONTROL BUILDING**  
**ROOF PLAN**

Drawing: **A-4C**  
 Sheet: **51** of **117**  
 File: P21-10530\_A-4C  
 Date: January 2023

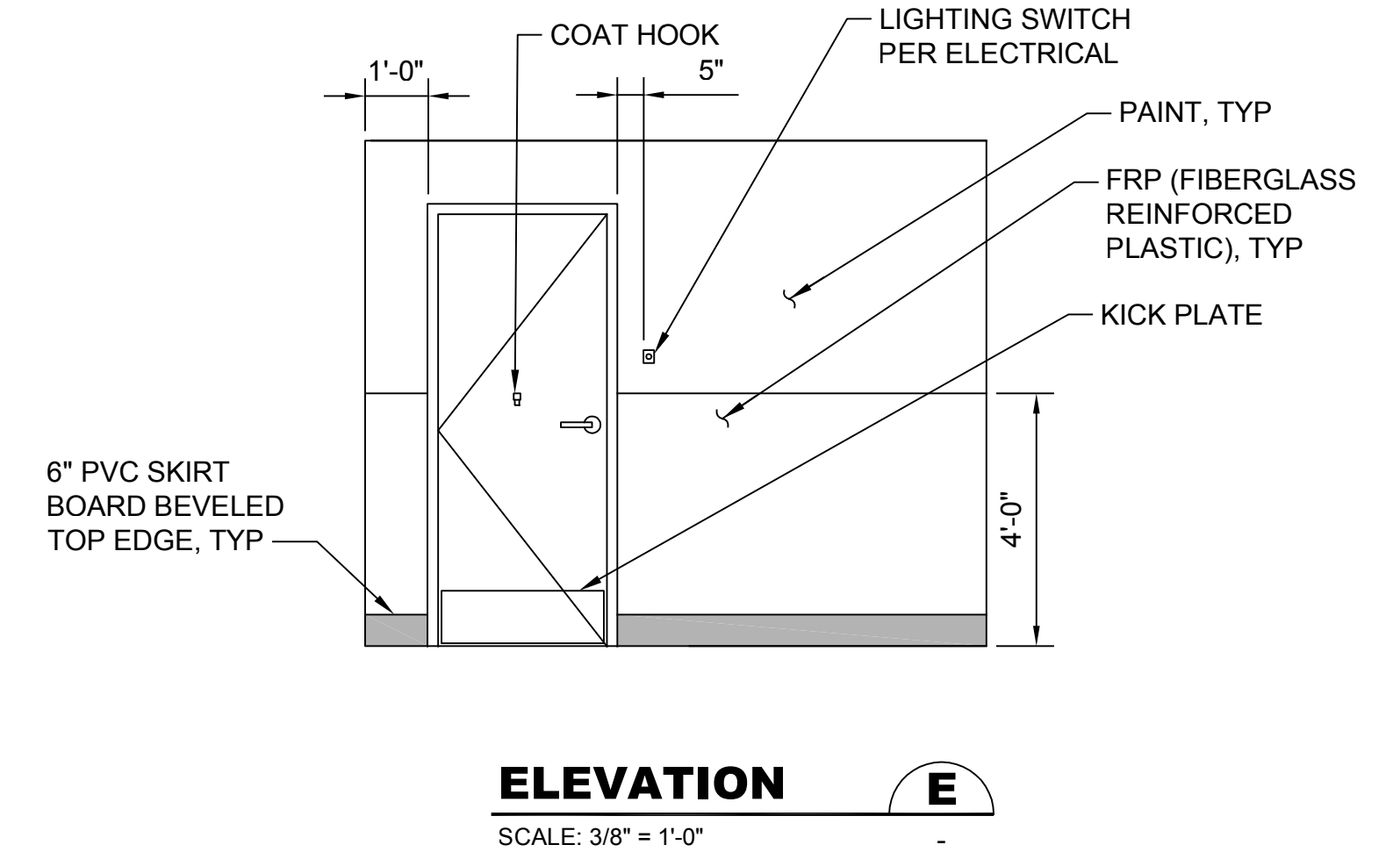
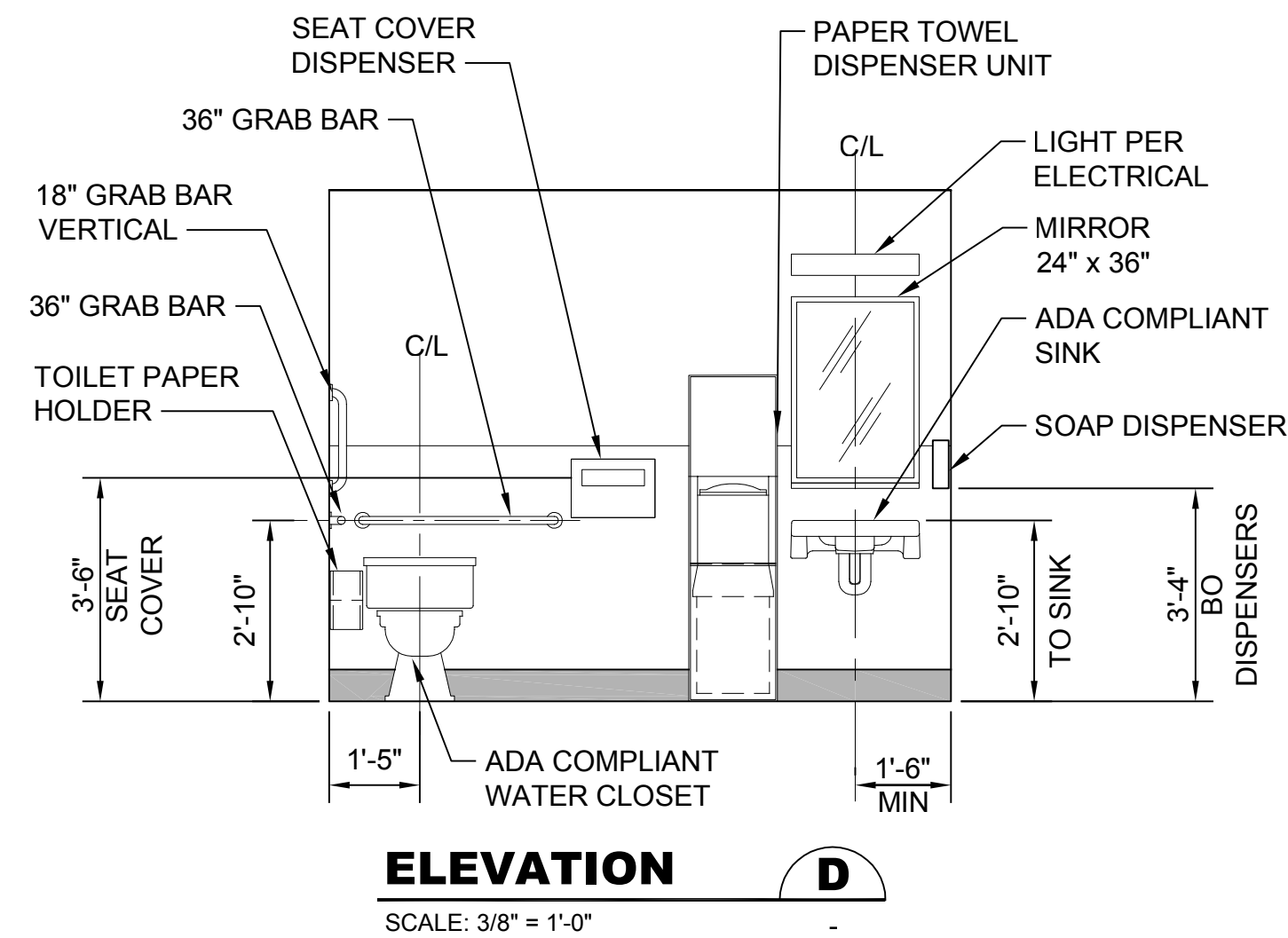
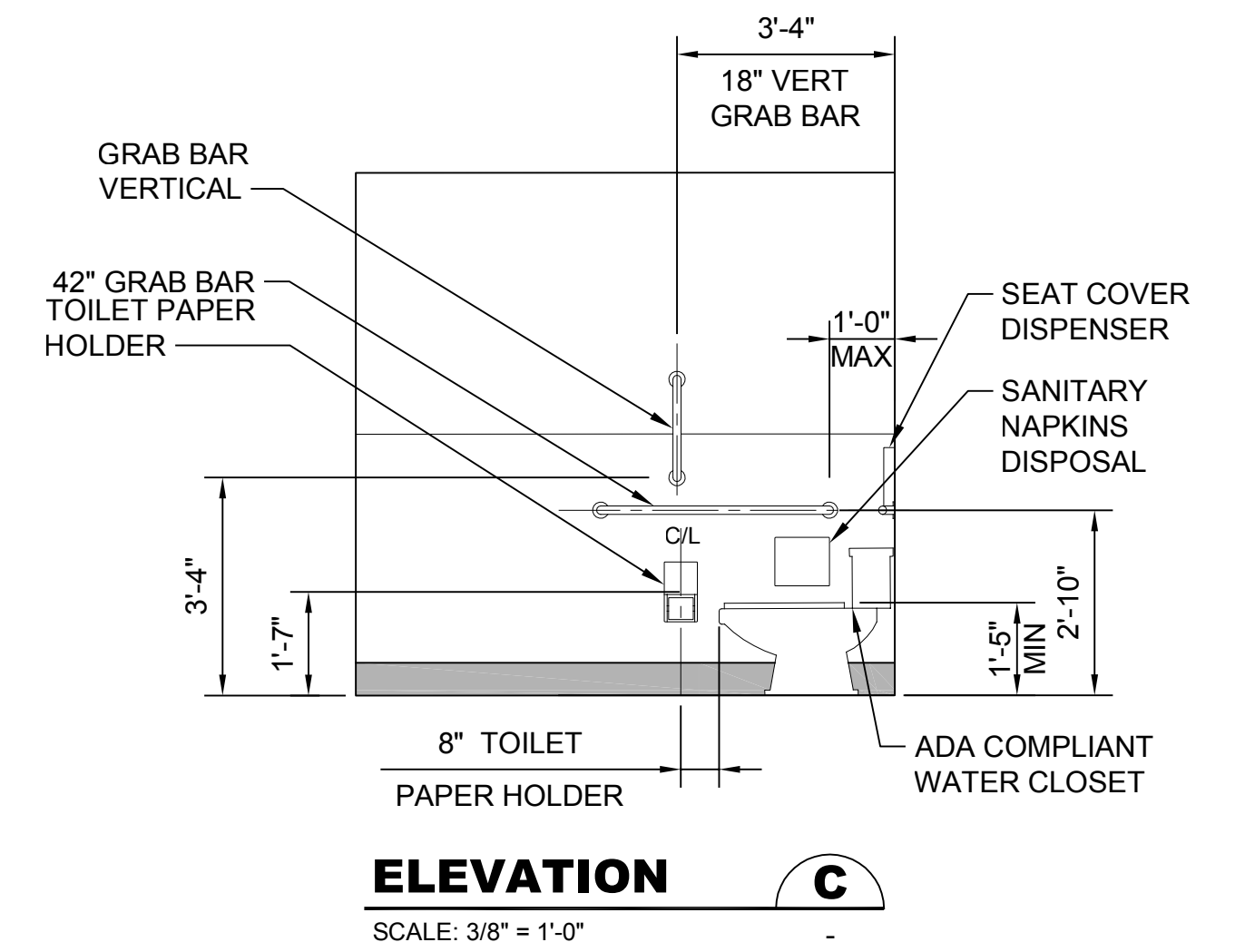
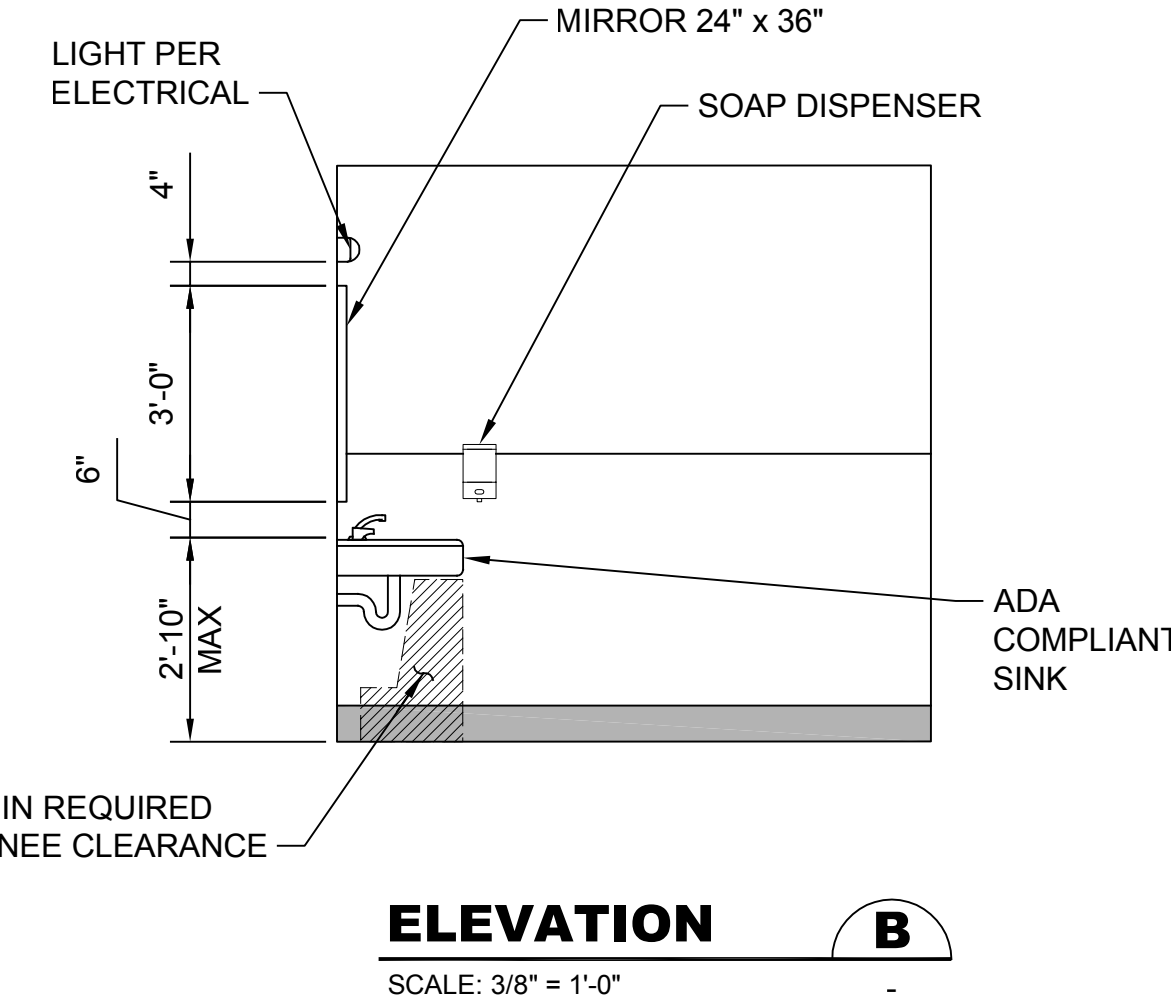
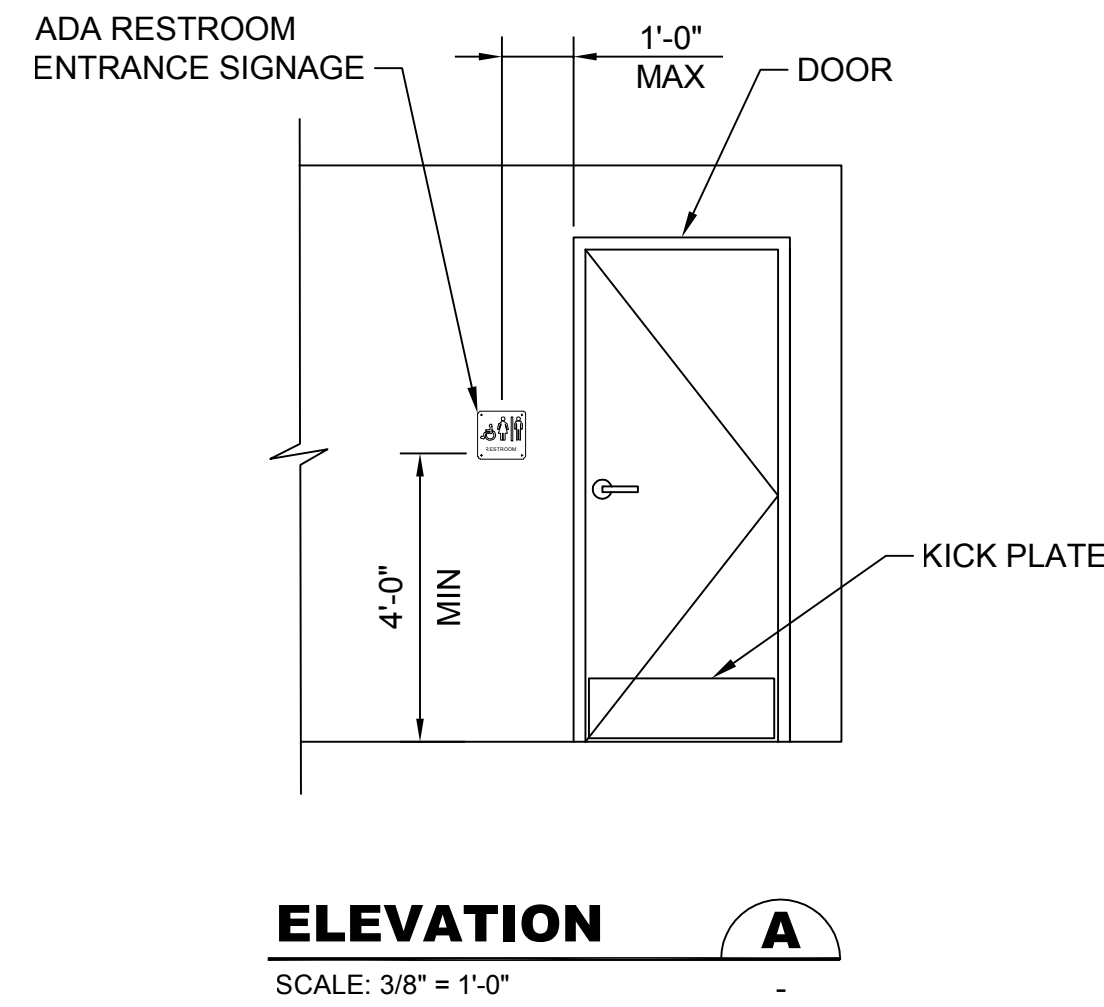
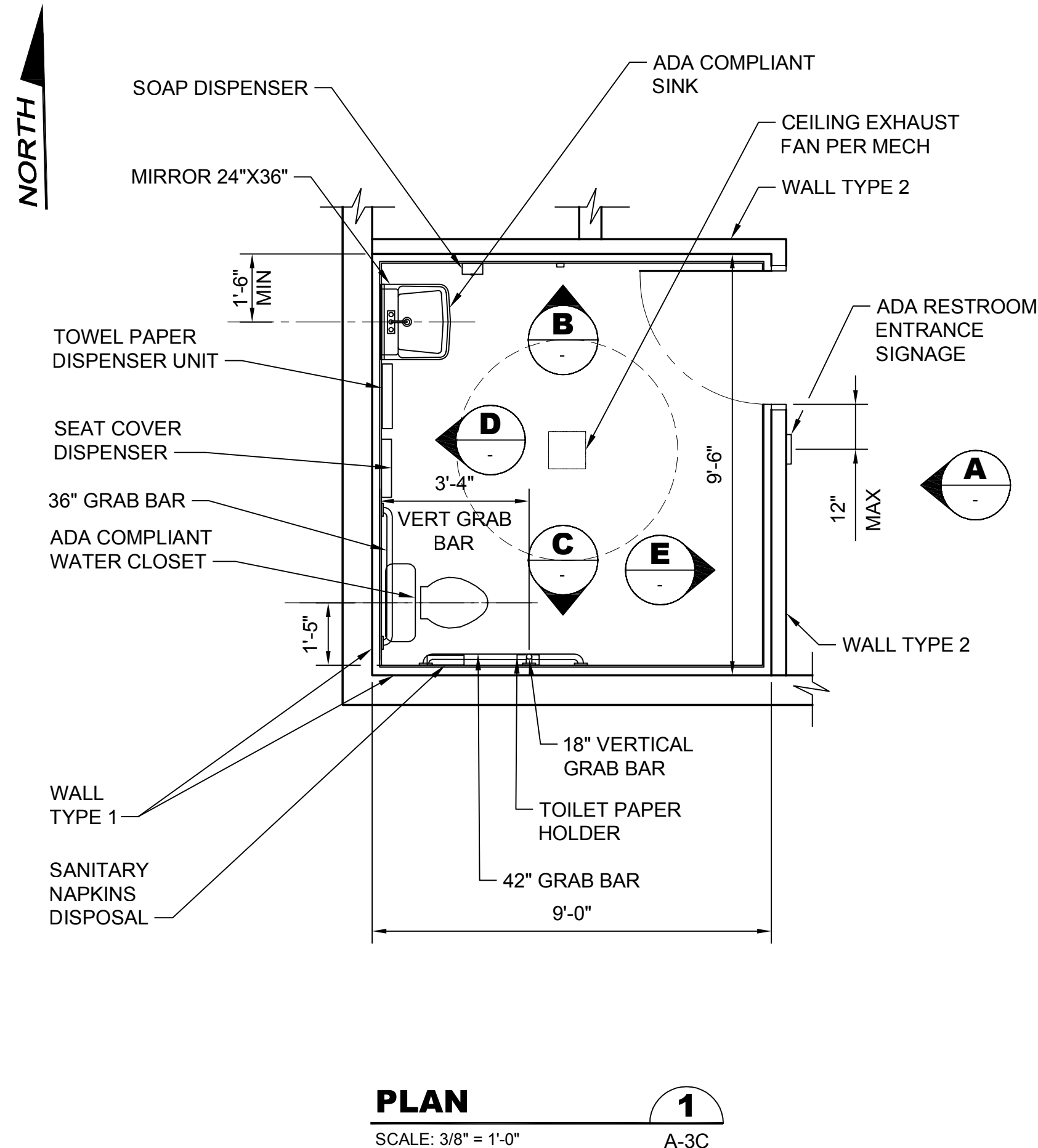

RESTROOM FIXTURE SCHEDULE					
NO.	DESCRIPTION	MANUFACTURER	MODEL	QUANTITY	REMARKS
1	GRAB BAR - 36"	BOBRICK	B-5806	1	
2	GRAB BAR - 42"	BOBRICK	B-5806	1	
3	GRAB BAR VERTICAL - 18"	BOBRICK	B-5806	1	
4	TOILET SEAT COVER DISPENSER	BOBRICK	B-4221	1	
5	TOILET TISSUE DISPENSER	BOBRICK	B-2888	1	
6	SANITARY NAPKINS DISPOSAL	BOBRICK	B-270	1	
7	SOAP DISPENSER	BOBRICK	B-4112	1	
8	COAT HOOK	BOBRICK	B-682	1	
9	ADA RESTROOM ENTRANCE SIGNAGE	ADA SIGN DEPOT	ADA-1245	1	
10	KICK PLATE	IVES HARDWARE	IVES 8400 10 x 32" US32D	2	TO BE INSTALLED BOTH SIDE OF THE DOOR.
11	MIRROR	BOBRICK	B-1658	1	PROVIDE SHIM FOR MIRROR ATTACHMENT.
12	PAPER TOWEL DISPENSER & WASTE RECEPTACLE	BOBRICK	B-43949	1	

NOTE: ALL FUTURE CONSTRUCTION EXCEPT FOR KICK PLATES.

RESTROOM FINISH SCHEDULE				
FLOOR	WALL	CEILING	BASE	REMARKS
SEALED CONCRETE	FRP (FIBERGLASS REINFORCED PLASTIC) W/ PAINTED GWB ABOVE	PAINTED GWB OVER 1/2" PLYWOOD	6" PVC SKIRT BOARD BEVELED TOP EDGE	

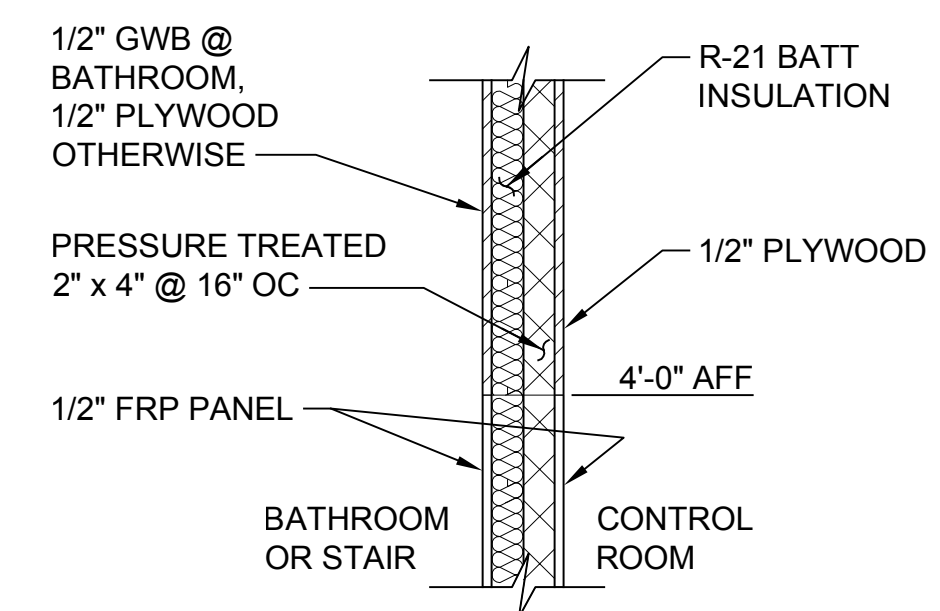
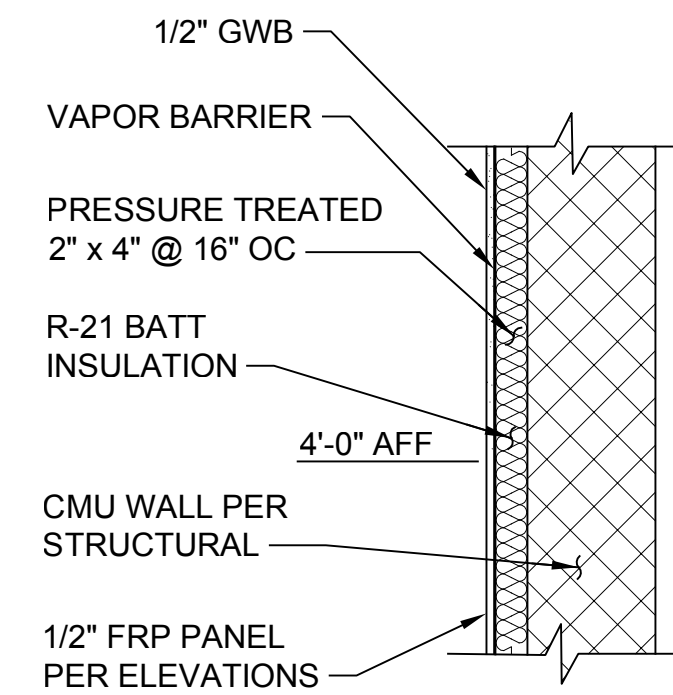

Call 48 Hours Before You Dig  
1-800-424-5555  
UNDERGROUND SERVICE

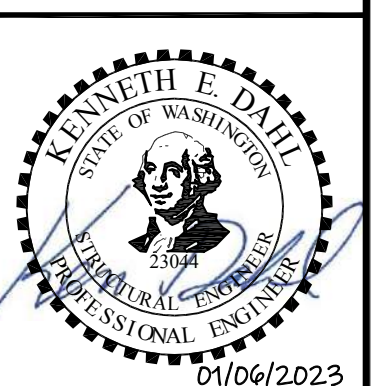

Path: S:\Cadd\Kitsap County\21-10530 Silverdale Conveyance-PS 4 Uprgr\Design\Drawings\21-10530\_A-5C Restroom Details.dwg  
Xref Filename: [Dahl] \21-10530\_TB [Fisher] [Palmer] [

No.	Revision	Date	By	App'd
	ISSUED FOR BID	01-2023	TF	RAD

**bhc**  
CONSULTANTS

**BHC Consultants, LLC**  
1601 Fifth Avenue, Suite 500  
Seattle, Washington 98101  
206.505.3400  
206.505.3406 (fax)  
www.bhcconsultants.com

Designed: K. Dahl, P.E., S.E.  
Drawn: A. Bradley  
Checked: T. Fisher, P.E.

Scale:  
1/4" = 1'-0"  
One Inch at Full Scale  
If Not One Inch Scale Accordingly



**Kitsap County Public Works**  
614 Division Street, MS 26  
Port Orchard, WA 98366

**SILVERDALE CONVEYANCE SYSTEM AND PUMP STATION 4 UPGRADES  
SCHEDULE C**

**RESTROOM DETAILS**

Drawing: **A-5C**  
Sheet: **52** of **117**  
File: P21-10530\_A-5C  
Date: January 2023

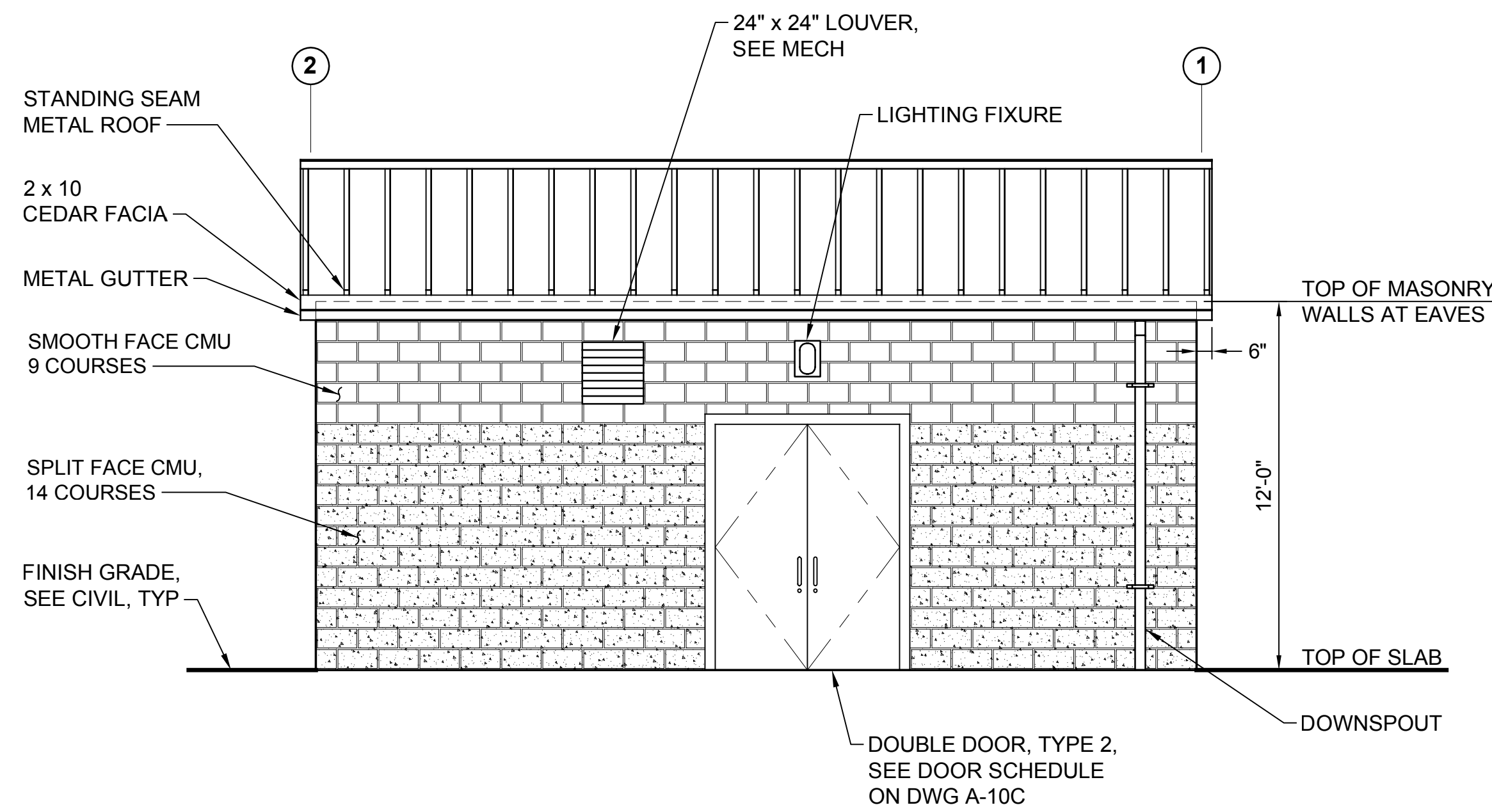

**NORTH ELEVATION**

SCALE: 1/4" = 1'-0"

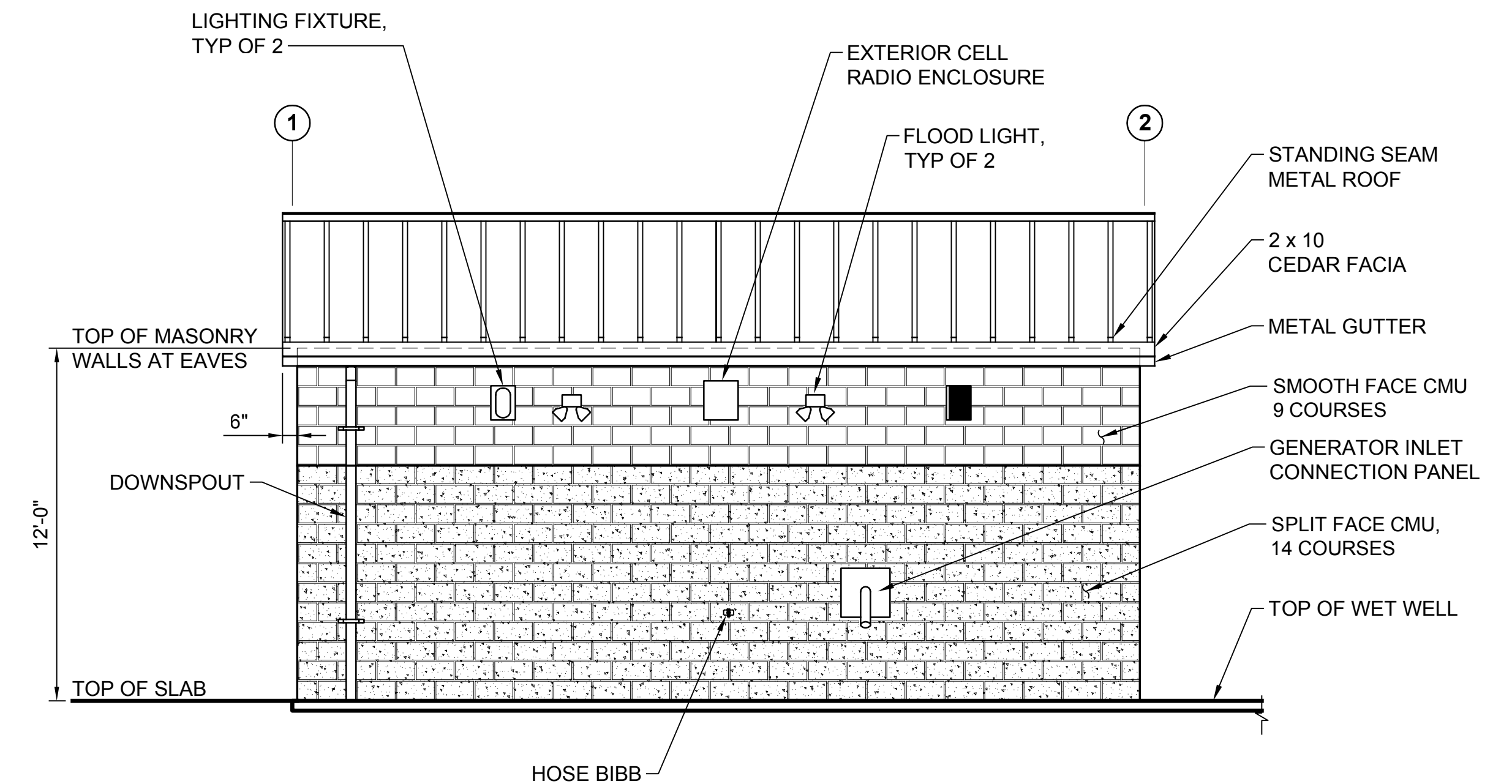

**SOUTH ELEVATION**

SCALE: 1/4" = 1'-0"

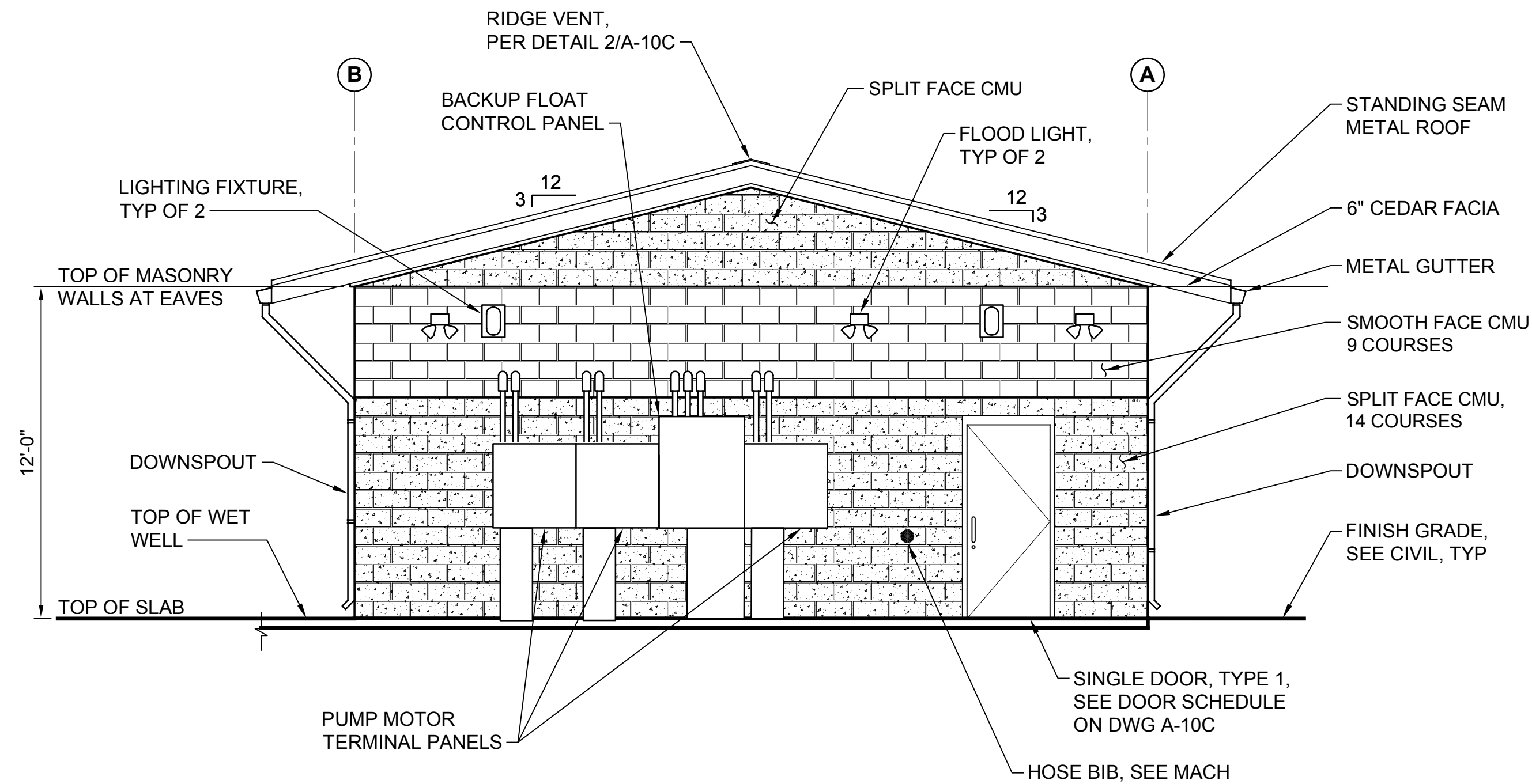

**EAST ELEVATION**

SCALE: 1/4" = 1'-0"

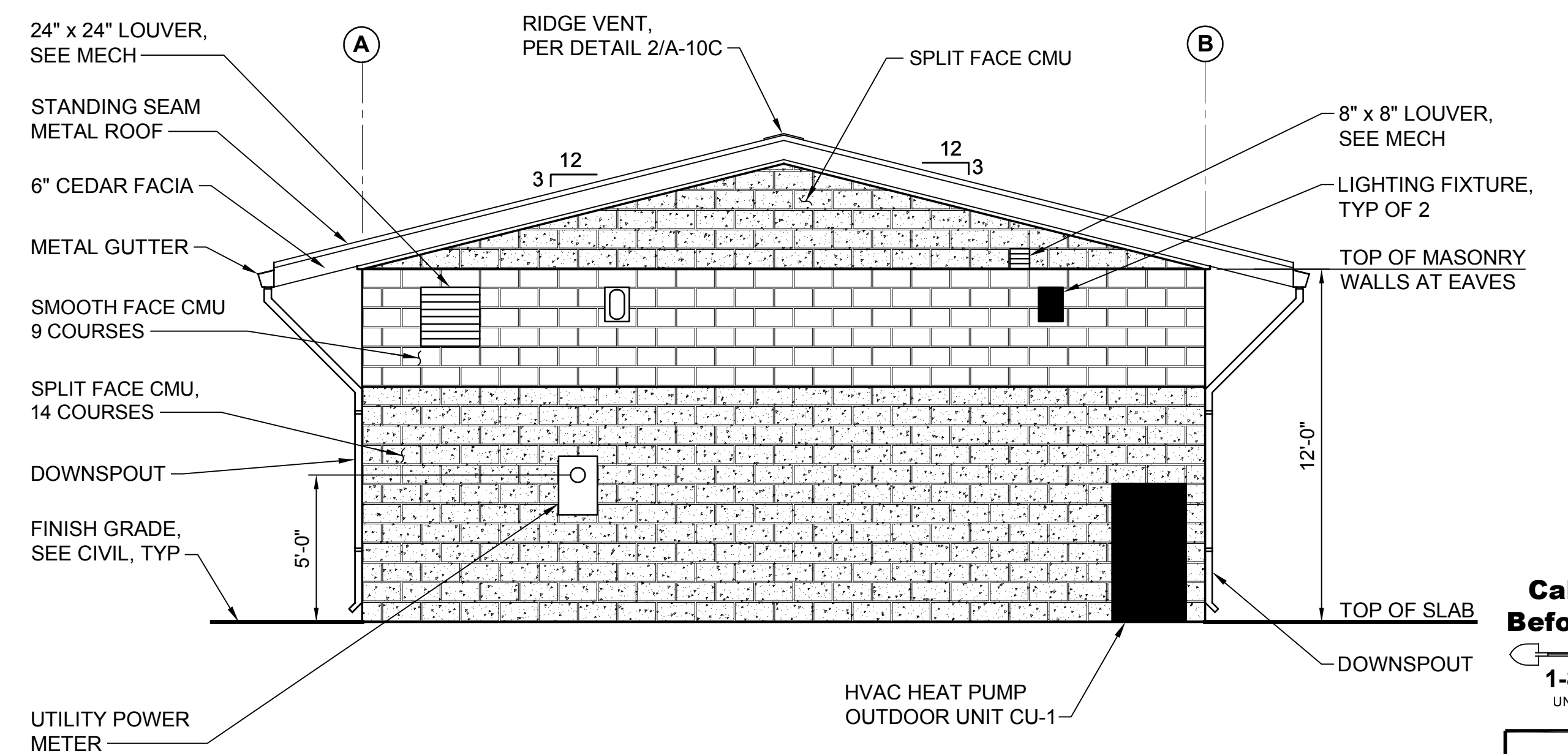

**WEST ELEVATION**

SCALE: 1/4" = 1'-0"

Path: S:\CAD\Kitsap County\21-10530 Silverdale Convey-PS 4 Uprgr\Design\Drawings\A-6C.dwg, File: P21-10530\_A-6C.dwg, Date: 01/06/2023 09:07:43am, CAD User: JLi, Xref File Name: 1\X21-10530\_TB1\X21-10530-PS4\_Prop Bldg Elev | X21-10530-PS4\_Prop Bldg Elev | X21-10530-PS4\_Prop Elec | Detail | Fisher | Palminter

**Call 48 Hours Before You Dig**  
1-800-424-5555  
UNDERGROUND SERVICE

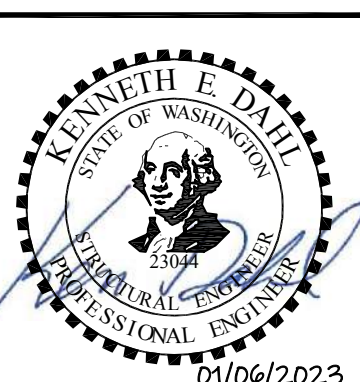

No.	Revision	Date	By	App'd
	ISSUED FOR BID	01-2023	TF	RAD



**BHC Consultants, LLC**  
1601 Fifth Avenue, Suite 500  
Seattle, Washington 98101  
206.505.3400  
206.505.3406 (fax)  
www.bhcconsultants.com

Designed: K. Dahl, P.E., S.E.  
Drawn: S. Olsoe  
Checked: T. Fisher, P.E.

Scale:  
1/4" = 1'-0"  
One Inch at Full Scale  
If Not One Inch Scale Accordingly



**Kitsap County Public Works**  
614 Division Street, MS 26  
Port Orchard, WA 98366

**SILVERDALE CONVEYANCE SYSTEM AND PUMP STATION 4 UPGRADES SCHEDULE C**

**CONTROL BUILDING ARCHITECTURAL ELEVATIONS**

Drawing: **A-6C**  
Sheet: **53** of **117**  
File: P21-10530\_A-6C  
Date: January 2023

**NOTES:**

1. SEE SECTION B/- FOR NOTES IN COMMON.

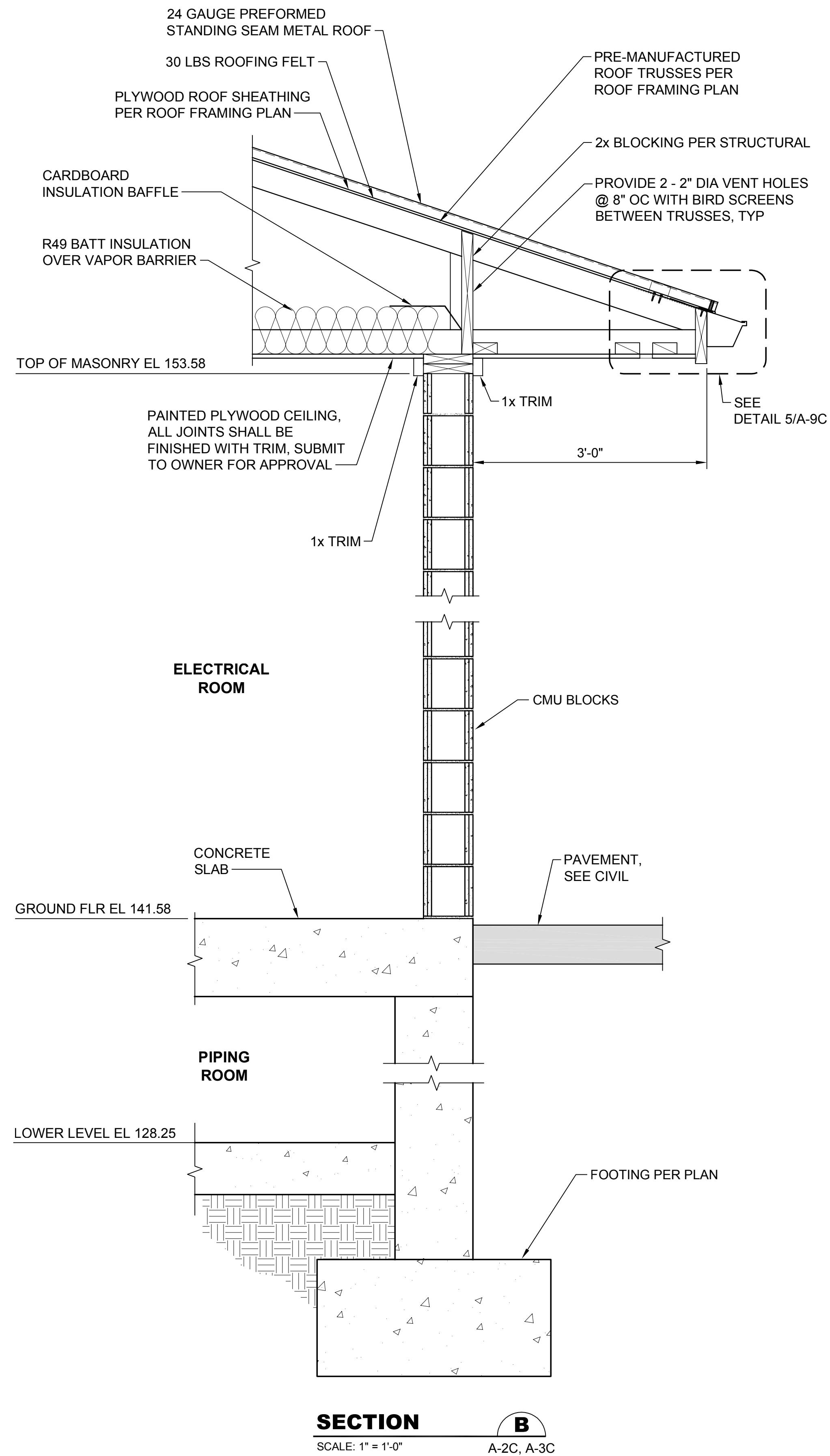
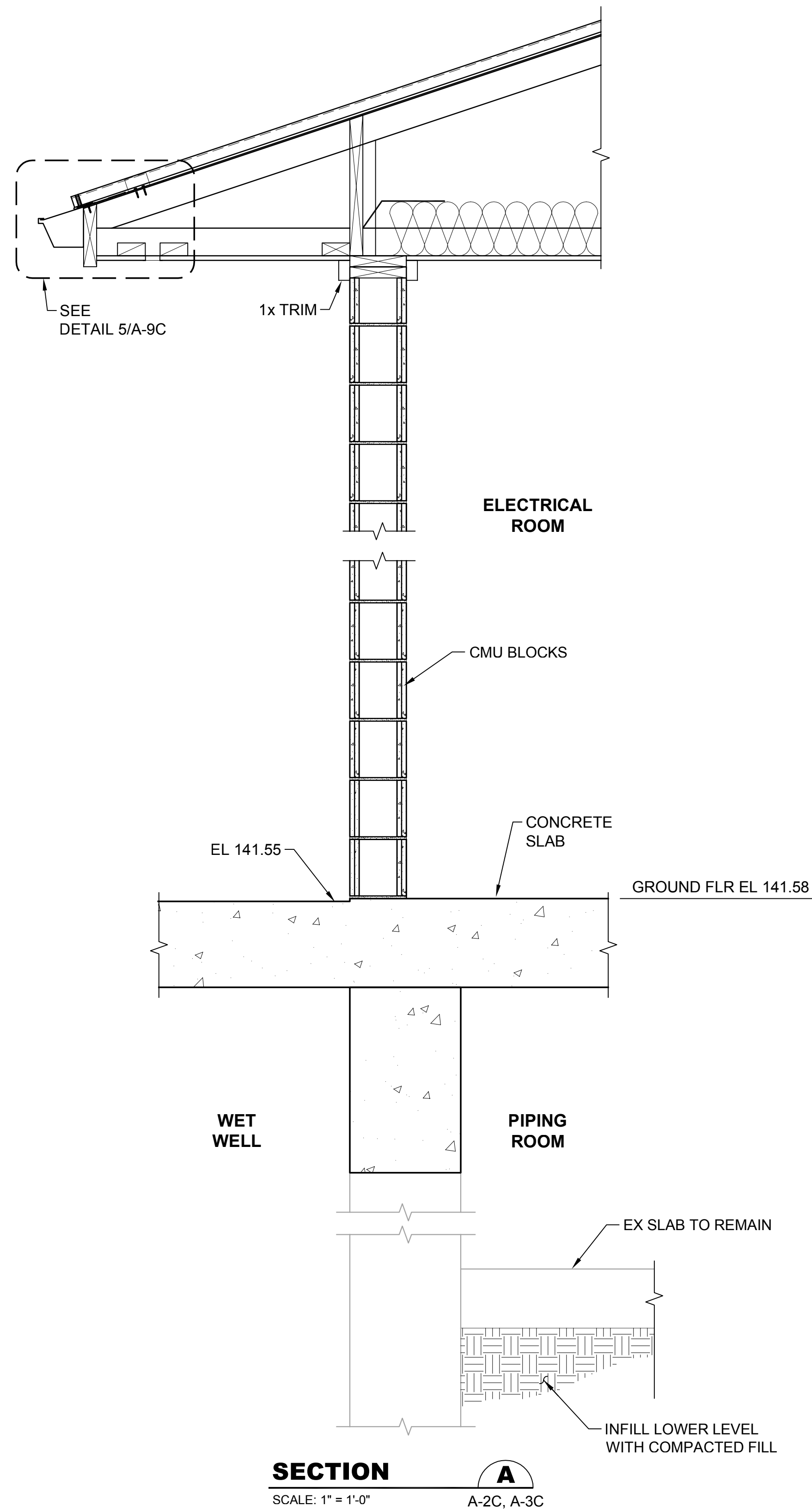

Path: S:\CAD\Kitsap County\21-10530 Silverdale Conveyance-PS 4 Upgr\Design\Drawings\21-10530\_A-7C.dwg  
 Xref Filename: 21-10530\_TB | Fisher | Dan | Palmieri |

**Call 48 Hours Before You Dig**  
**1-800-424-5555**  
 UNDERGROUND SERVICE

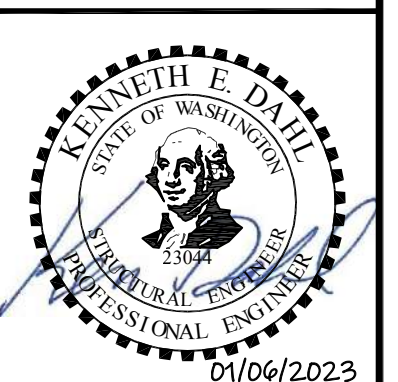

No.	Revision	Date	By	App'd
	ISSUED FOR BID	01-2023	TF	RAD

**bhc**  
**CONSULTANTS**  
**BHC Consultants, LLC**  
 1601 Fifth Avenue, Suite 500  
 Seattle, Washington 98101  
 206.505.3400  
 206.505.3406 (fax)  
 www.bhcconsultants.com

Designed: K. Dahl, P.E., S.E.  
 Drawn: A. Bradley  
 Checked: T. Fisher, P.E.

Scale:  
 As Shown  
 One Inch at Full Scale  
 If Not One Inch Scale Accordingly



**Kitsap County Public Works**  
 614 Division Street, MS 26  
 Port Orchard, WA 98366

**SILVERDALE CONVEYANCE SYSTEM AND PUMP STATION 4 UPGRADES**  
**SCHEDULE C**  
**CONTROL BUILDING**  
**ARCHITECTURAL SECTIONS**  
**1 OF 2**

Drawing: **A-7C**  
 Sheet: **54** of **117**  
 File: P21-10530\_A-7C  
 Date: January 2023

Path: S:\Cad\Kitsap County\21-10530 Silverdale Convey-PS 4 Uprgt\Design\Drawings\21-10530\_A-8C\_Prop Bldg Jan 06, 2023 09:12:40am CAD User: JLra  
 Xref Filename: 21-10530-PS4\_TB | Fisher | Dahl | 21-10530-PS4\_Prop Bldg | 21-10530-PS4\_Ex Bldg | 21-10530-PS4\_Prop Grid | Palmler |

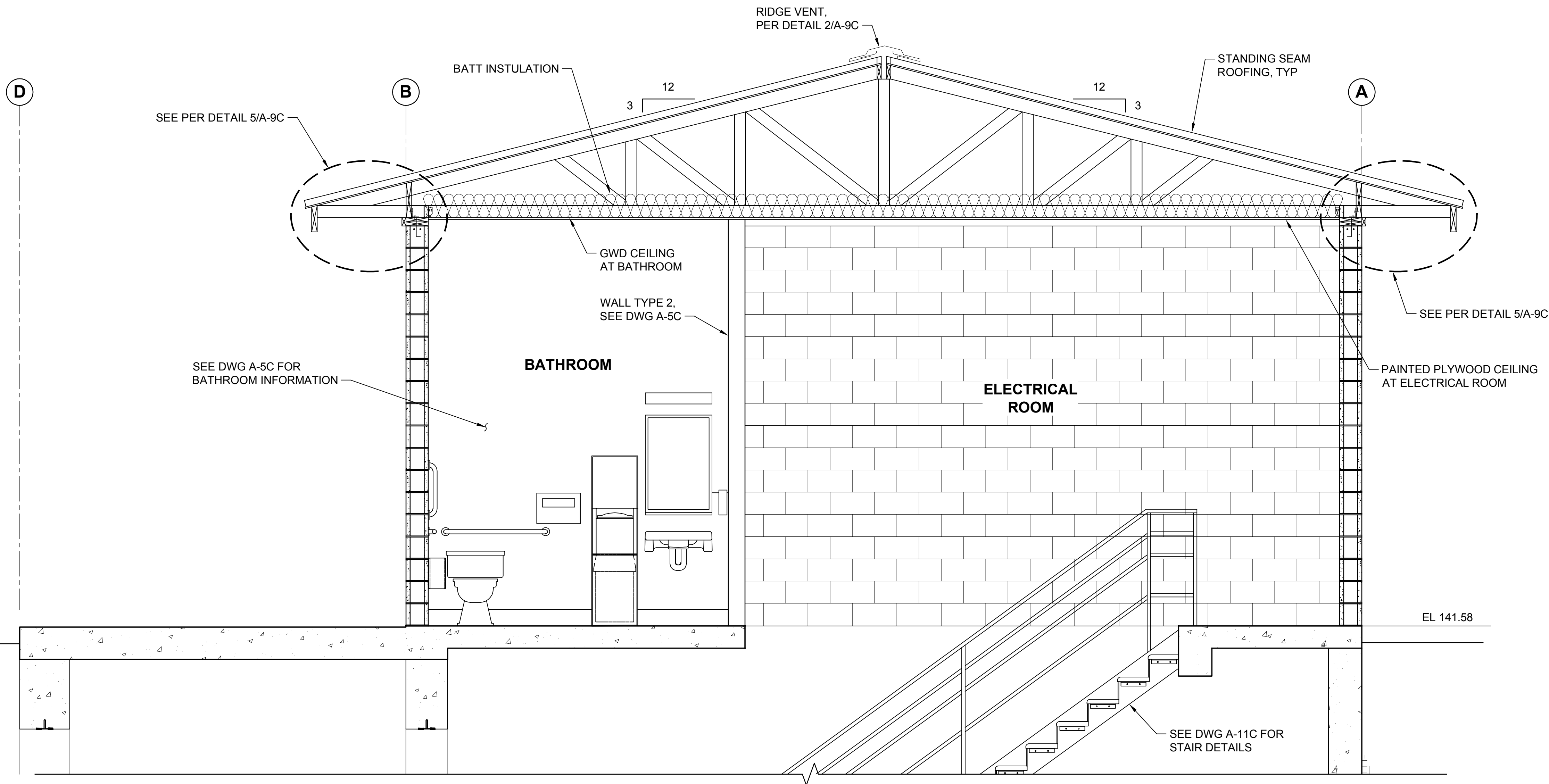

**SECTION**



A-2C

SCALE: 3/8" = 1'-0"

**Call 48 Hours Before You Dig**

**1-800-424-5555**  
UNDERGROUND SERVICE

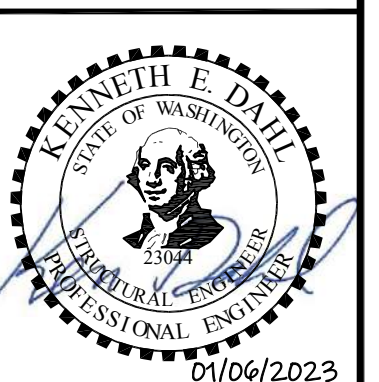

No.	Revision	Date	By	App'd
	ISSUED FOR BID	01-2023	TF	RAD



**BHC Consultants, LLC**  
 1601 Fifth Avenue, Suite 500  
 Seattle, Washington 98101  
 206.505.3400  
 206.505.3406 (fax)  
 www.bhcconsultants.com

Designed: K. Dahl, P.E., S.E.  
 Drawn: A. Bradley  
 Checked: T. Fisher, P.E.

Scale:  
 3/8" = 1'-0"  
 One Inch at Full Scale  
 If Not One Inch Scale Accordingly



**Kitsap County Public Works**  
 614 Division Street, MS 26  
 Port Orchard, WA 98366

**SILVERDALE CONVEYANCE SYSTEM AND PUMP STATION 4 UPGRADES**  
**SCHEDULE C**  
**CONTROL BUILDING**  
**ARCHITECTURAL SECTIONS**  
**2 OF 2**

Drawing: **A-8C**  
 Sheet: **55** of **117**  
 File: P21-10530-PS4\_A-8C  
 Date: January 2023

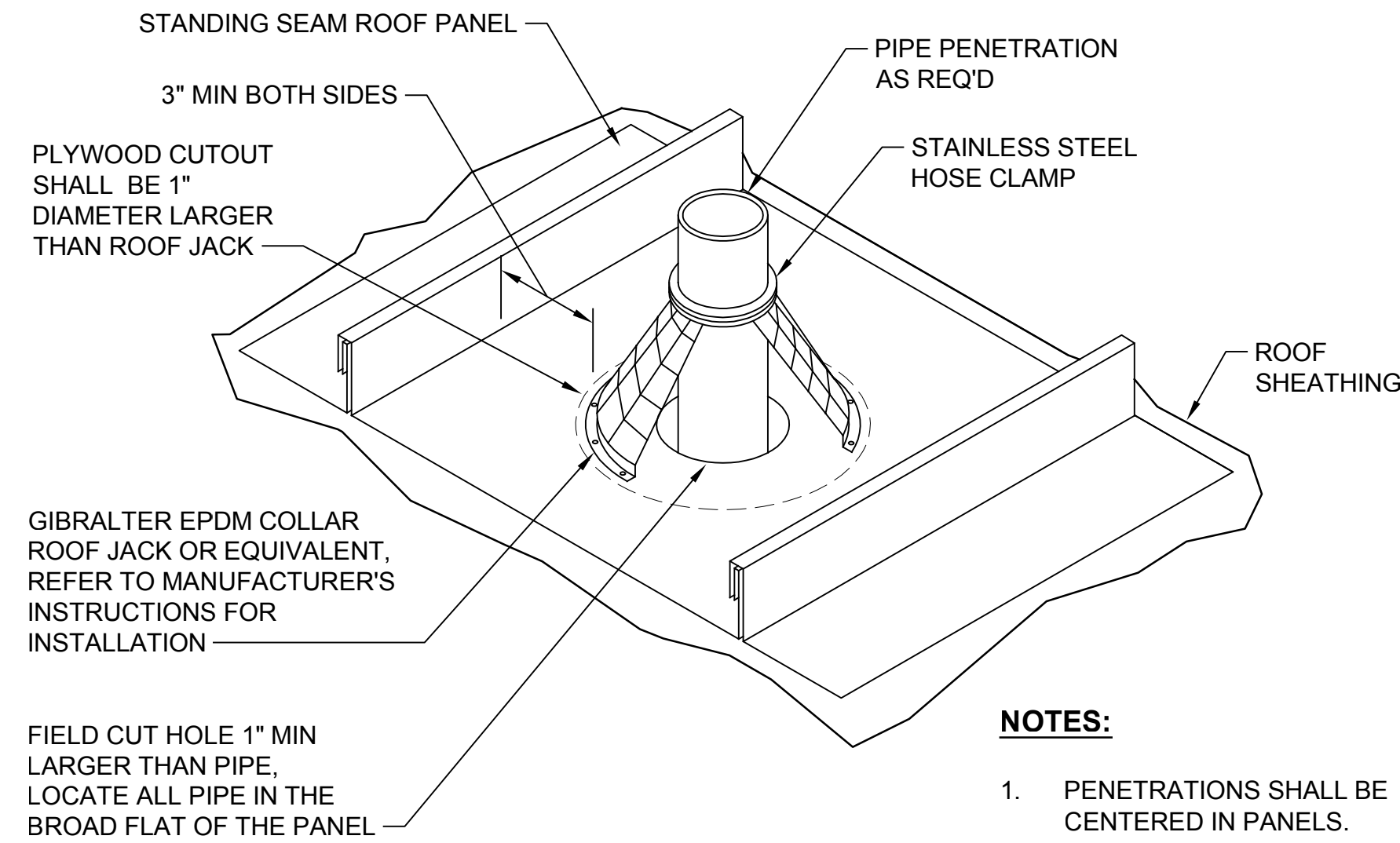

**ROOF PENETRATION  
DETAIL**

1  
NTS TYP

- NOTES:**
1. PENETRATIONS SHALL BE CENTERED IN PANELS.

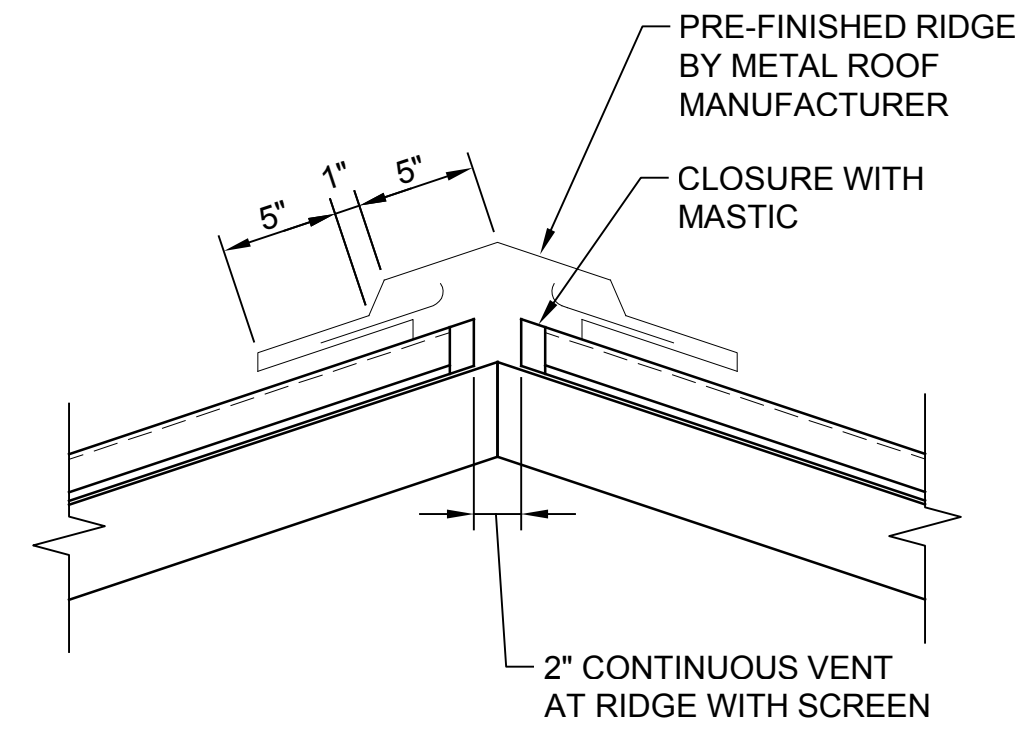

**RIDGE VENT  
DETAIL**

2  
NTS TYP

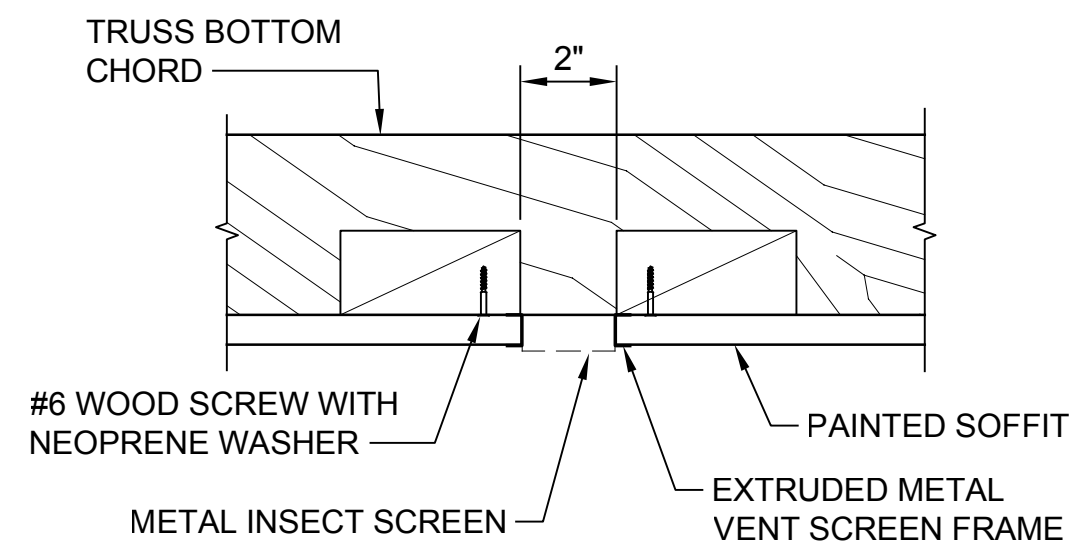

**SOFFET VENT  
DETAIL**

3  
NTS TYP

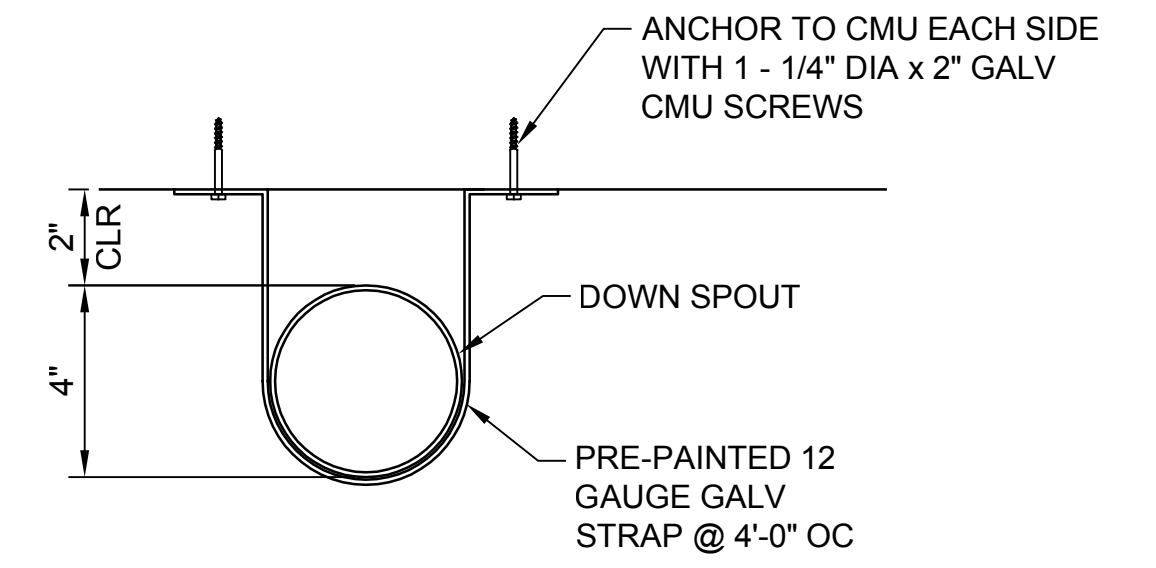

**DOWNSPOUT  
DETAIL**

4  
NTS TYP

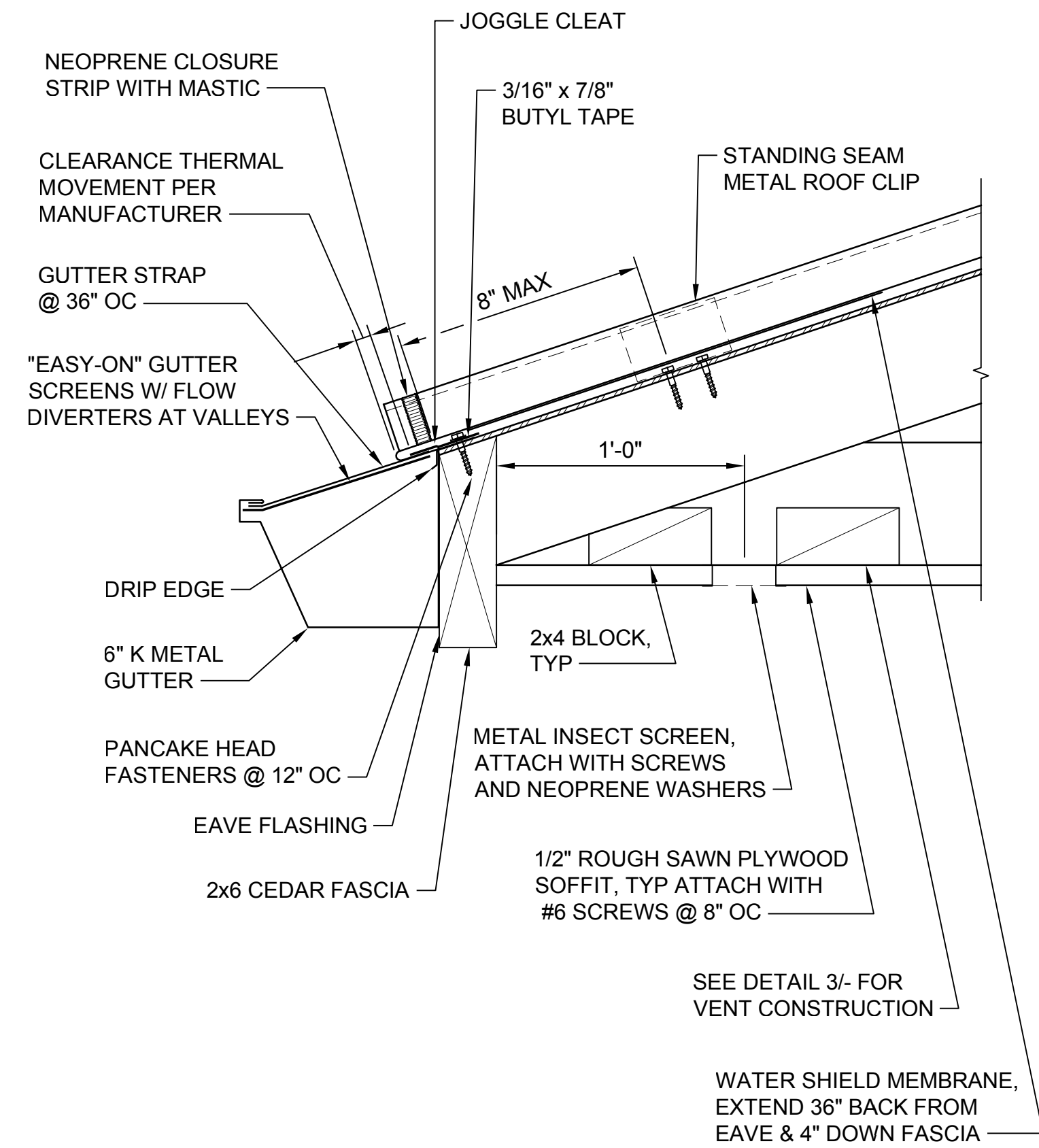

**EAVE  
DETAIL**

5  
NTS TYP

**Call 48 Hours  
Before You Dig**  
1-800-424-5555  
UNDERGROUND SERVICE

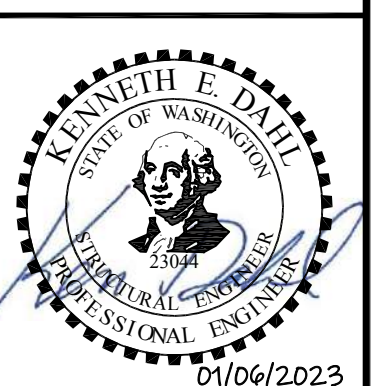

Path: S:\Cadd\Kitsap County\21-10530 Silverdale Convey-PS 4 \Upgr\Design\Drawings\A-9C\_P21-10530\_A-9C.dwg, Date: 01/06/2023, 09:14:18am, CAD User: J.Lira, Xref Filename: 1\21-10530\_TB\1\Fisher\Dan\Palmer\

No.	Revision	Date	By	App'd
	ISSUED FOR BID	01-2023	TF	RAD



**BHC Consultants, LLC**  
1601 Fifth Avenue, Suite 500  
Seattle, Washington 98101  
206.505.3400  
206.505.3406 (fax)  
www.bhcconsultants.com

Designed: K. Dahl, P.E., S.E.  
Drawn: A. Bradley  
Checked: T. Fisher, P.E.

Scale:  
As Shown  
One Inch at Full Scale  
If Not One Inch Scale Accordingly



**Kitsap County Public Works**  
614 Division Street, MS 26  
Port Orchard, WA 98366

**SILVERDALE CONVEYANCE SYSTEM AND PUMP STATION 4 UPGRADES  
SCHEDULE C**  
**TYPICAL ARCHITECTURAL  
EXTERIOR DETAILS**

Drawing: **A-9C**  
Sheet: **56** of **117**  
File: P21-10530\_A-9C  
Date: January 2023



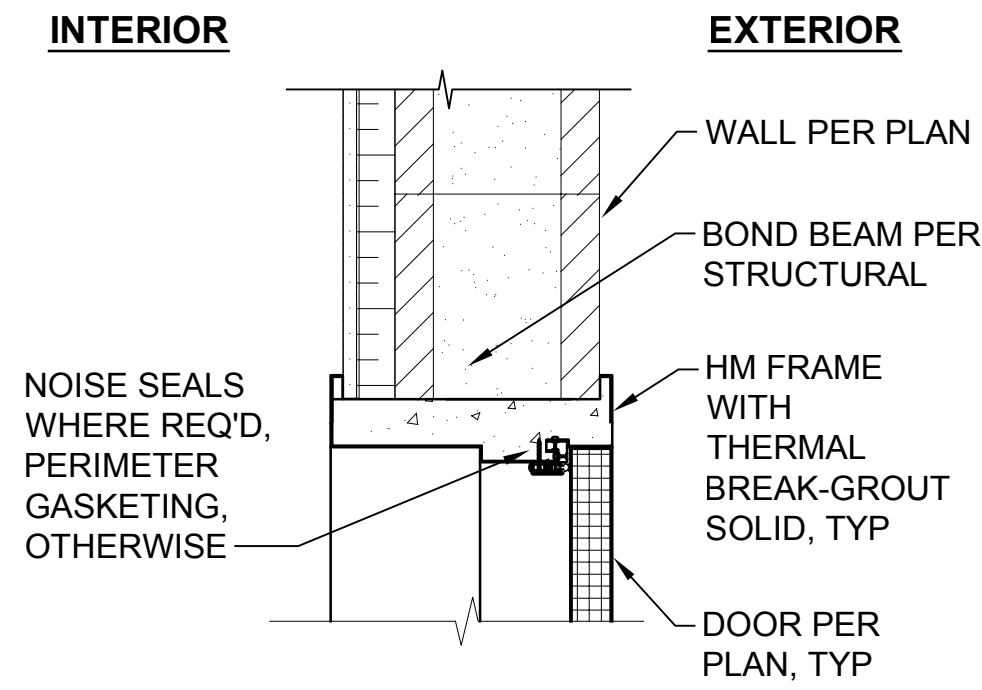

**DOOR HEAD  
DETAIL 1**  
SCALE: 1 1/2" = 1'-0"  
TYP

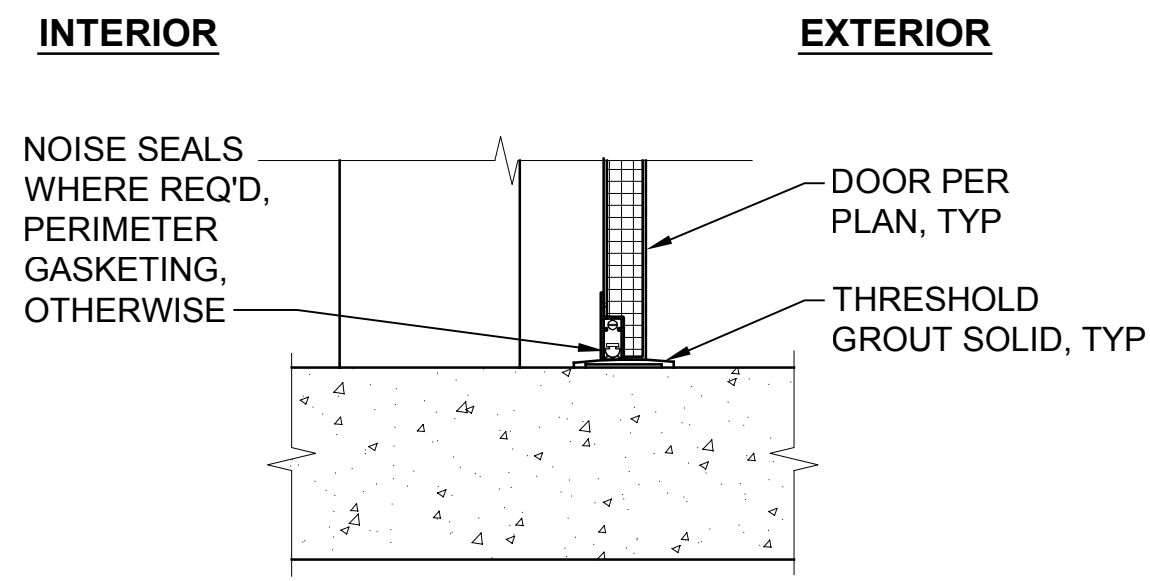

**DOOR THRESHOLD  
DETAIL 2**  
SCALE: 1 1/2" = 1'-0"  
TYP

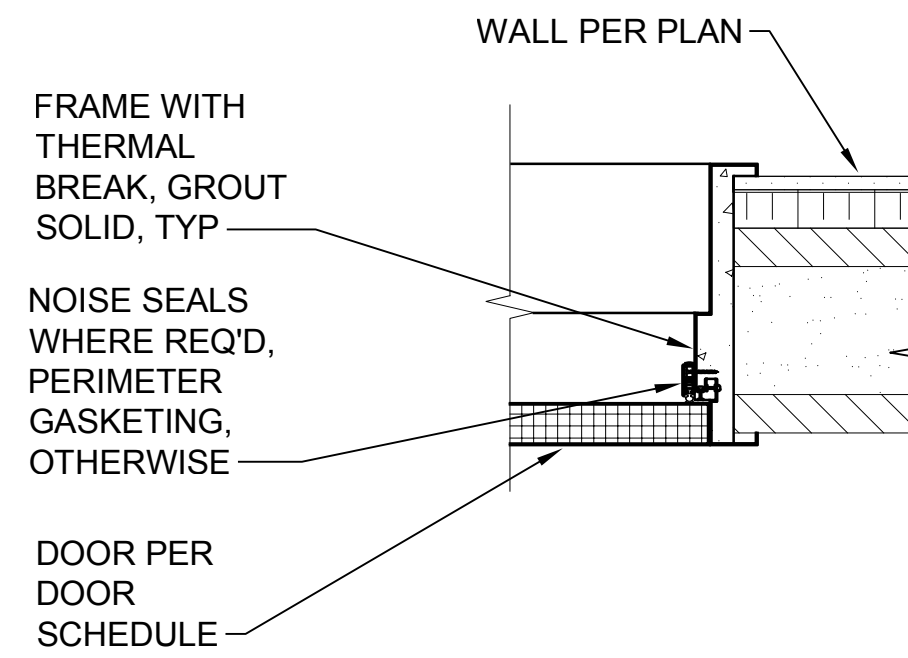

**DOOR JAMB  
DETAIL 3**  
SCALE: 1 1/2" = 1'-0"  
TYP

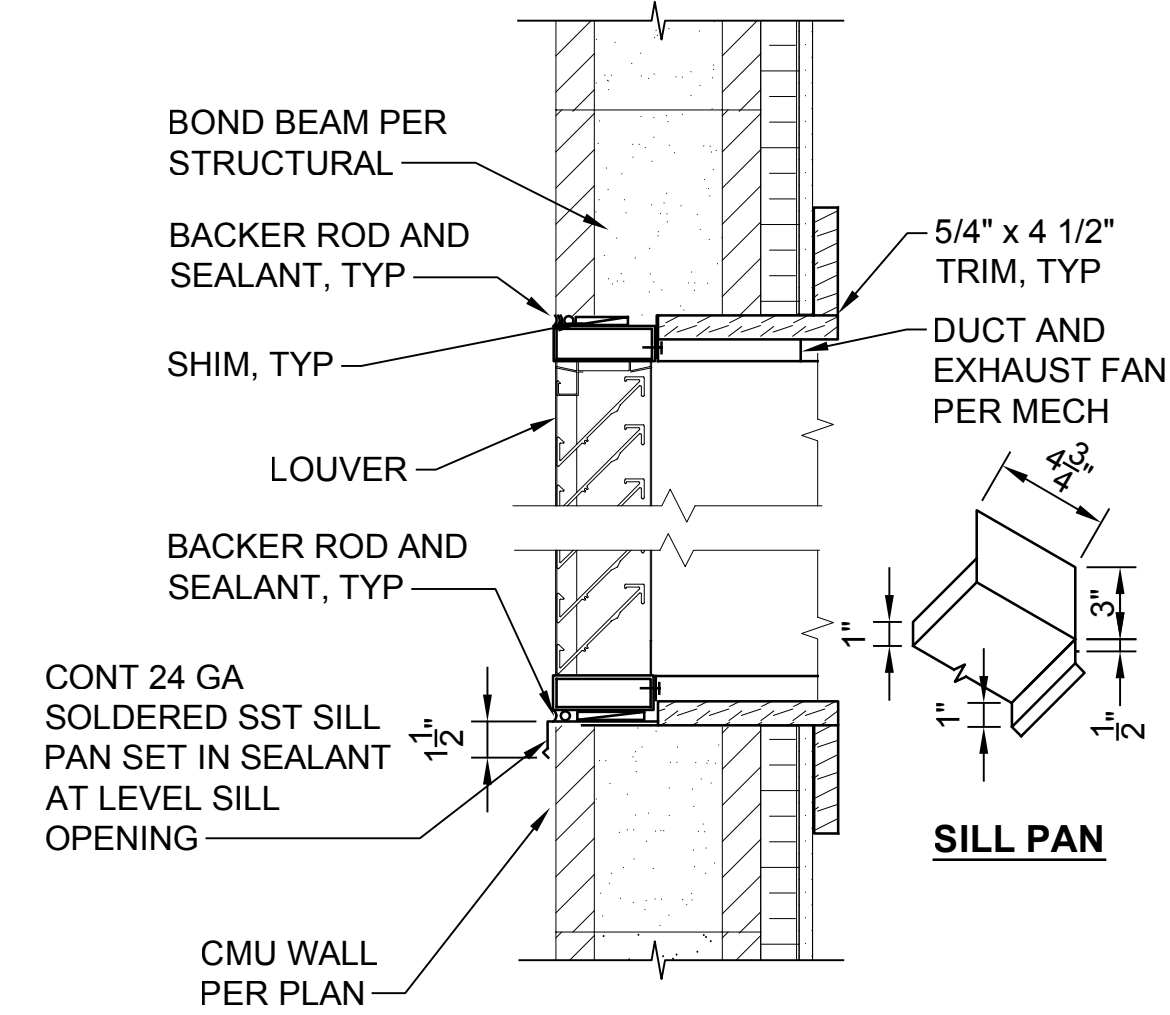

**LOUVER  
DETAIL 4**  
SCALE: 1 1/2" = 1'-0"  
TYP

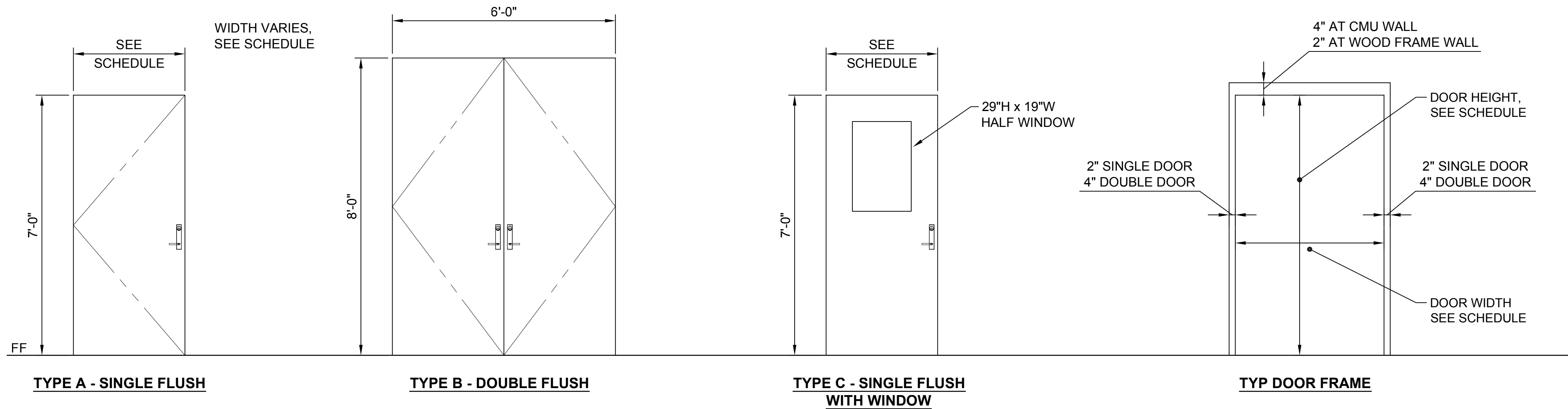

DOOR SCHEDULE								DOOR HARDWARE SCHEDULE								COMMENTS
MARK	TYPE	WIDTH	HEIGHT	DOOR MATERIAL	DOOR FINISH	FRAME MATERIAL	FRAME FINISH	SEE SPECIFICATIONS FOR DETAILED INFORMATION								
								HINGES	PASSAGE LEVER	DEAD BOLT	WEATHERSTRIP RING	DOOR STOP / HOLD OPEN	CLOSER	EXTENSION BOLT	ASTRAGAL	
1	A	3'-0"	7'-0"	STEEL/INSULATED	PAINT	HM	PAINT	YES	YES	YES	YES	YES	YES	NO	NO	KEY ALL LOCKS PER COUNTY REQUIREMENTS
2	B	6'-0"	8'-0"	STEEL/INSULATED	PAINT	HM	PAINT	YES	YES	YES	YES	YES	YES	YES	YES	KEY ALL LOCKS PER COUNTY REQUIREMENTS
3	C	3'-0"	7'-0"	STEEL	PAINT	HM	PAINT	YES	YES	NO	NO	YES	YES	NO	NO	NO LOCK SYSTEM
4	A	3'-0"	7'-0"	STEEL	PAINT	HM	PAINT	YES	YES	NO	NO	YES	YES	NO	NO	

**Call 48 Hours  
Before You Dig**  
1-800-424-5555  
UNDERGROUND SERVICE

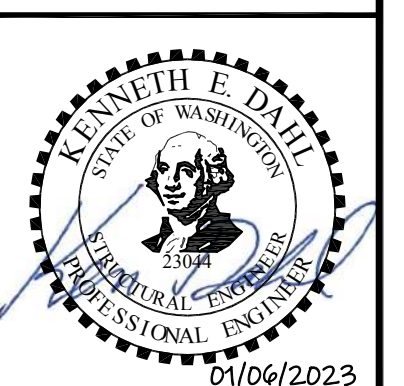

Path: S:\Cadd\Kitsap County\21-10530 Silverdale Conveyance-PS-4 Upgr\Design\Drawings\21-10530\_A-10C\_Plot.dwg; Plot date: Jan 06, 2023 09:16:23am; CAD User: J.Lira; Xref Filename: 21-10530-PS-4\_TB | Dahl | Fisher | Palmatier

No.	Revision	Date	By	App'd
	ISSUED FOR BID	01-2023	TF	RAD

**bhc**  
CONSULTANTS  
BHC Consultants, LLC  
1601 Fifth Avenue, Suite 500  
Seattle, Washington 98101  
206.505.3400  
206.505.3406 (fax)  
www.bhcconsultants.com

Designed: K. Dahl, P.E., S.E.  
Drawn: J. Lira  
Checked: R. Dorn, P.E.  
Scale: As Shown  
One Inch at Full Scale  
If Not One Inch Scale Accordingly

**Kitsap County Public Works**  
614 Division Street, MS 26  
Port Orchard, WA 98366

**SILVERDALE CONVEYANCE SYSTEM AND PUMP STATION 4 UPGRADES  
SCHEDULE C  
TYPICAL DOOR AND LOUVER  
DETAILS**

Drawing: **A-10C**  
Sheet: **57** of **117**  
File: P19-10530\_A-10C  
Date: January 2023

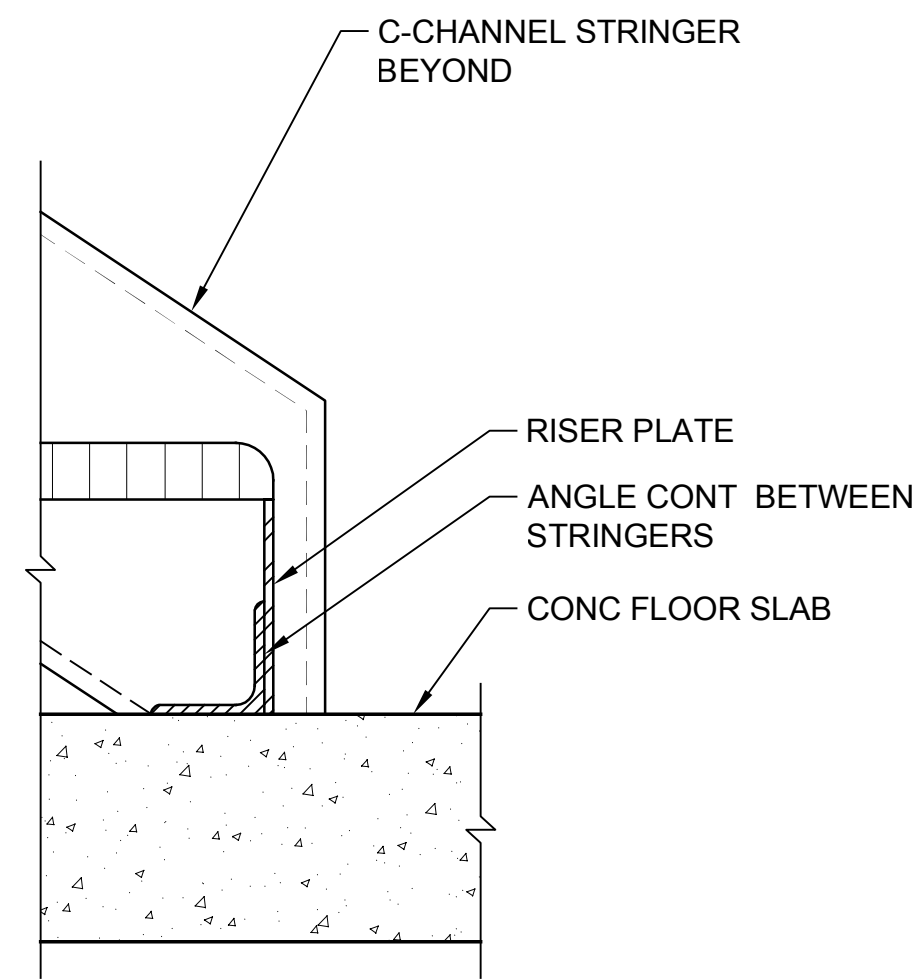

**TYPICAL STAIR BOTTOM CONNECTION**

**DETAIL**



SCALE: 3" = 1'-0"

A-8C

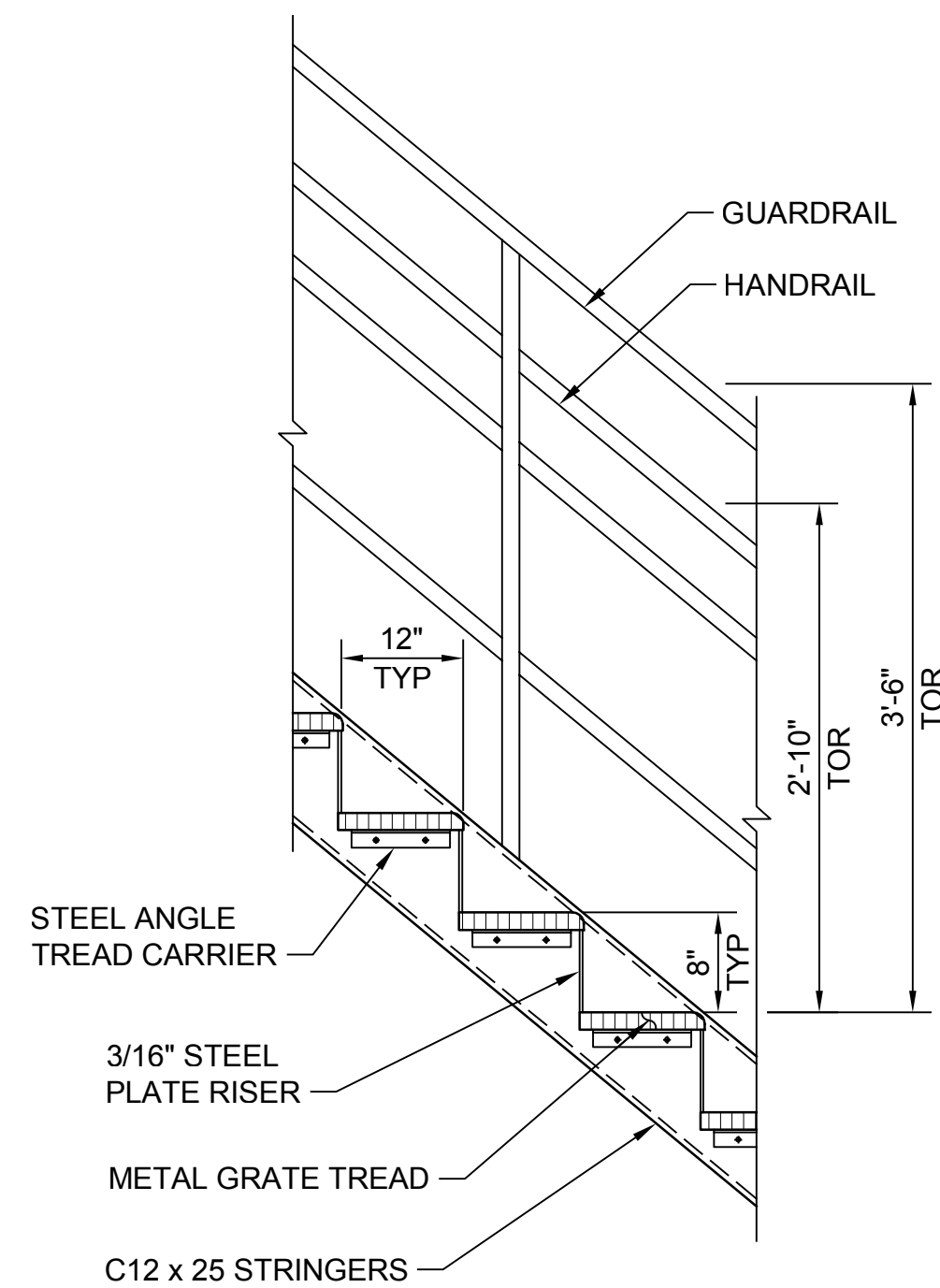

**TYPICAL STAIR SECTION**

**DETAIL**



SCALE: 1" = 1'-0"

A-8C

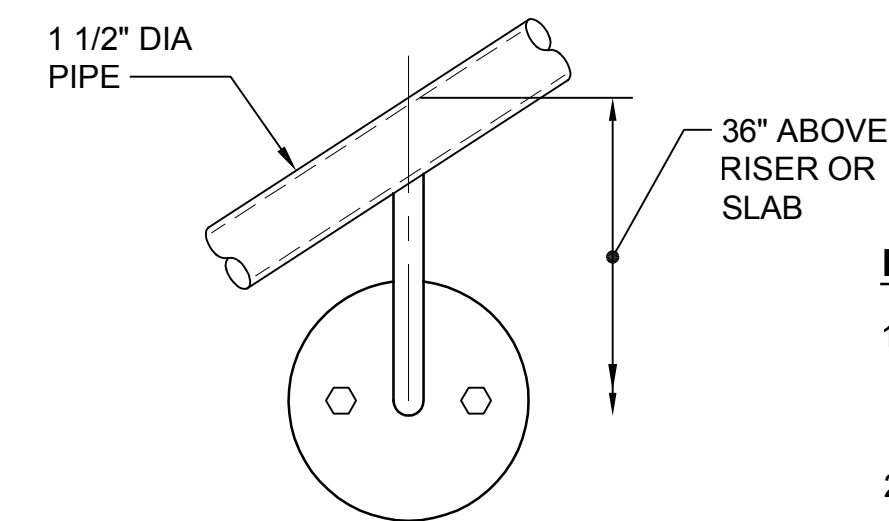

**ELEVATION**

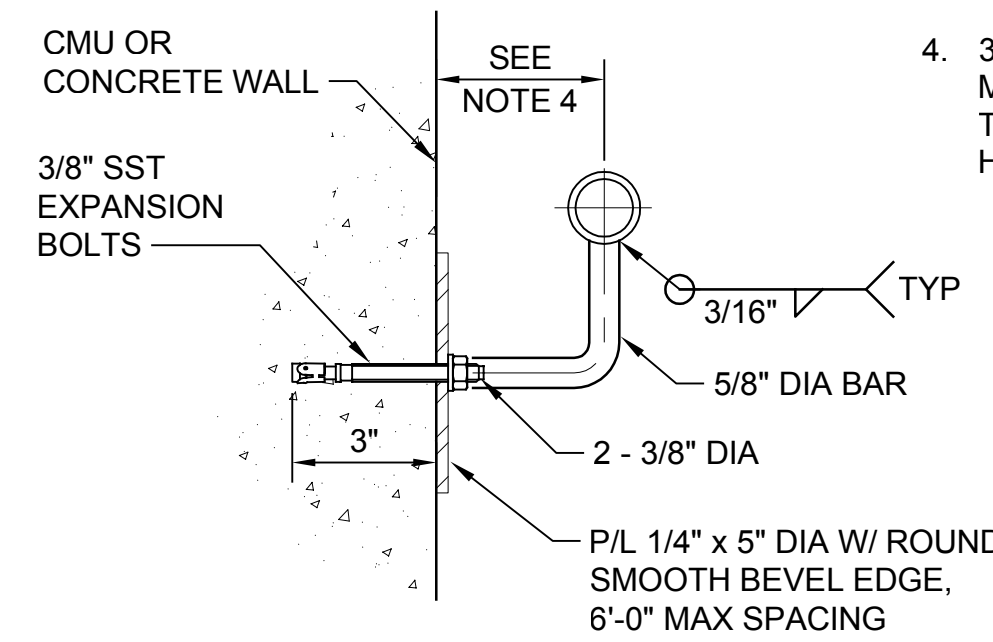

**SIDE VIEW**

**HANDRAIL WALL MOUNTING**

**DETAIL**

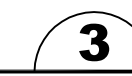

SCALE: 3" = 1'-0"

A-8C

**NOTE:**

1. AT CMU WALL, LOCATE ATTACHMENTS IN GROUTED CELLS.
2. PROVIDE FLAT END CAPS AT TOP AND BOTTOM.
3. RAIL TO MATCH ELEVATION AND EXTENT OF OPPOSITE TOP RAIL.
4. 3-1/2" AT CONC WALL, FIELD MEASURE FOR CMU WALL TO PROVIDE STRAIGHT HANDRAIL ALONG STAIR

Path: S:\Cad\Kitsap County\21-10530 Silverdale Convey-PS 4 UprgtDesign.d Filename: P21-10530\_A-11C Plot date: Jan 06, 2023 09:25:04am CAD User: J.Lira  
 Xref Filename: I:\21-10530-PS4\_TB\Fisher\Dahl\Palmtier

**Call 48 Hours Before You Dig**  
 1-800-424-5555  
 UNDERGROUND SERVICE



No.	Revision	Date	By	App'd
	ISSUED FOR BID	01-2023	TF	RAD

**bhc**  
**CONSULTANTS**

**BHC Consultants, LLC**  
 1601 Fifth Avenue, Suite 500  
 Seattle, Washington 98101  
 206.505.3400  
 206.505.3406 (fax)  
 www.bhcconsultants.com

Designed: K. Dahl, P.E., S.E.  
 Drawn: P. Simon  
 Checked: T. Fisher, P.E.

Scale:  
 As Shown  
 One Inch at Full Scale  
 If Not One Inch Scale Accordingly



**Kitsap County Public Works**  
 614 Division Street, MS 26  
 Port Orchard, WA 98366

**SILVERDALE CONVEYANCE SYSTEM AND PUMP STATION 4 UPGRADES**  
**SCHEDULE C**

**STAIR DETAILS**

Drawing: **A-11C**  
 Sheet: **58** of **117**  
 File: P21-10530\_A-11C  
 Date: January 2023

GENERAL STRUCTURAL NOTES

A. GENERAL

1. SCOPE
THE GENERAL STRUCTURAL NOTES AND TYPICAL STRUCTURAL DETAILS ARE GENERAL AND APPLY TO THE ENTIRE PROJECT EXCEPT WHERE THERE ARE SPECIFIC INDICATIONS OR MODIFICATIONS TO THE CONTRARY.

2. APPLICABLE SPECIFICATIONS AND CODES
ALL CONSTRUCTION SHALL BE IN ACCORDANCE WITH THE BUILDING CODE, (SEE BELOW). THE PROVISIONS OF THE BUILDING CODE SHALL SUPERSEDE THE PLANS AND SPECIFICATIONS EXCEPT WHERE THE PLANS AND SPECIFICATIONS ARE MORE RESTRICTIVE.

IN ADDITION TO THE BUILDING CODE, CONSTRUCTION SHALL CONFORM TO OTHER STANDARDS AND CODES AS REFERENCED ON THE DRAWINGS OR IN THE SPECIFICATIONS.

3. DIMENSIONS
STRUCTURAL DIMENSIONS CONTROLLED BY OR RELATED TO MECHANICAL AND ELECTRICAL EQUIPMENT SHALL BE VERIFIED BY THE CONTRACTOR PRIOR TO CONSTRUCTION.

REFER TO MECHANICAL AND ELECTRICAL DRAWINGS FOR SIZE AND LOCATION OF ALL OPENINGS FOR DUCTS, PIPING, CONDUITS, ETC., NOT SHOWN. ALL OPENINGS IN STRUCTURAL MEMBERS SHALL BE APPROVED BY THE STRUCTURAL ENGINEER. REFER TO CIVIL DRAWINGS AND SPECIFICATIONS FOR SUBGRADE INFORMATION AND CRITERIA. VERIFY ALL DIMENSIONS WITH CIVIL, MECHANICAL, AND ELECTRICAL DRAWINGS.

4. PROVISIONS FOR EQUIPMENT
MECHANICAL AND ELECTRICAL EQUIPMENT SUPPORTS, ANCHORAGES, OPENINGS, PIPE SLEEVES AND, PENETRATIONS, RECESSES AND REVEALS NOT SHOWN ON THE STRUCTURAL DRAWINGS, BUT REQUIRED BY OTHER CONTRACT DRAWINGS SHALL BE PROVIDED FOR, PRIOR TO CASTING CONCRETE.

5. CONSTRUCTION LOADS
STRUCTURES HAVE BEEN DESIGNED FOR OPERATIONAL LOADS ON THE COMPLETED STRUCTURES. DURING CONSTRUCTION, THE STRUCTURES SHALL BE PROTECTED BY BRACING AND SUPPORTS WHEREVER EXCESSIVE CONSTRUCTION LOADS MAY OCCUR.

6. DRAINAGE SURFACES
SLOPE DRAINAGE SURFACES UNIFORMLY TO DRAIN. SLOPE SHALL BE 1/4" PER FOOT, EXCEPT WHERE NOTED OTHERWISE ON THE PLANS. AT CONTRACTOR'S OPTION, BOTTOM OF SLAB MAY BE LEVEL AND MAINTAIN A MINIMUM THICKNESS AT FLOOR DRAINS.

B. STRUCTURAL DESIGN DATA

1. GENERAL

A. BUILDING CODE: 2018 INTERNATIONAL BUILDING CODE WITH KITSAP COUNTY AMENDMENTS AND BY REFERENCE ASCE 7-16 MINIMUM DESIGN LOADS FOR AND BUILDINGS AND OTHER STRUCTURES.

B. OCCUPANCY: U
C. RISK CATEGORY IV
D. LOCATION: PS 4: 47.65° N, 122.66° W, EL 140

2. DESIGN LOADS

A. DEAD LOAD:
BUILDING STRUCTURE: ACTUAL PLUS 5 PSF COLLATERAL DEAD LOAD ON ROOF SYSTEM

B. LIVE LOAD
BUILDING FLOOR: 250 PSF
BUILDING ROOF: 25 PSF

C. SNOW LOAD
GROUND SNOW LOAD Pg: 30 PSF
FLAT-ROOF SNOW LOAD Pf: 31 PSF
SLOPING ROOF SNOW LOAD, PS: PSF
SNOW EXPOSURE FACTOR Ce: 1.0
SNOW LOAD IMPORTANCE FACTOR: Is = 1.2
THERMAL FACTOR Ct = 1.2

D. WIND DESIGN DATA
BASIC WIND SPEED (3 SECOND GUST): 115 MPH
WIND EXPOSURE: B ALL DIRECTIONS
INTERNAL PRESSURE COEFFICIENT: ENCLOSED. GCpi = +/- .18
INTERNAL PRESSURE: ± 7 PSF

B. STRUCTURAL DESIGN DATA (cont.)

E. EARTHQUAKE DESIGN DATA:

SEISMIC IMPORTANCE FACTOR: Ie = 1.50
SEISMIC DESIGN CATEGORY: D
BASIC FORCE RESISTING SYSTEM: SPECIAL REINFORCED MASONRY SHEARWALLS
SITE CLASS C
Ss = 1.465
Si = 0.519
Fa = 1.2
Fv = 1.481
SDS = 1.177
SD1 = 0.514

RESPONSE MODIFICATION FACTOR: 5.0
ANALYSIS PROCEDURE: EQUIVALENT STATIC FORCE PROCEDURE

F. SOILS DATA:

SOILS EXPLORATION INFORMATION IS CONTAINED IN "SILVERDALE PUMP STATION 4 UPGRADES TECHNICAL MEMO, PREPARED BY LANDAU ASSOCIATES DATED SEPTEMBER 24, 2021.

TRAFFIC SURCHARGE: 100 PSF
SOIL BEARING PRESSURE ON STRUCTURAL BACKFILL: 3.0 KSF STATIC, 4 KSF WITH WIND OR EARTHQUAKE

FROST DEPTH: 12 INCHES
SLIDING FRICTION COEFFICIENT: 0.35

C. CONCRETE

1. SPECIFICATION
SEE SPECIFICATIONS FOR COMPLETE REQUIREMENTS FOR MIX DESIGNS, FORMING, REINFORCEMENT, PLACING, CURING, AND FINISHING.

2. DESIGN STRESSES

A. CAST-IN-PLACE CONCRETE
- STRUCTURAL CONCRETE: 4000 PSI AT 28 DAYS
- PLAIN CONCRETE: 3000 PSI AT 28 DAYS

STRUCTURAL CONCRETE SHALL BE USED FOR FOUNDATIONS, WALLS, SLABS, EQUIPMENT PADS, AND ALL LOAD BEARING CONCRETE. ALL OTHER CONCRETE SHALL BE PLAIN CONCRETE.

B. REINFORCING STEEL SHALL BE ASTM A615 DEFORMED BARS, GRADE 60. WELDED WIRE FABRIC SHALL BE ASTM A185 SMOOTH WIRE - fy = 60 KSI MINIMUM.

3. BAR SPLICES
SPLICES OF REINFORCING STEEL BARS SHALL BE IN ACCORDANCE WITH THE BUILDING CODE AND SHALL BE CLASS B, UNLESS OTHERWISE NOTED. THE LENGTH OF LAP SPLICE OF BARS OF DIFFERENT DIAMETER SHALL BE BASED ON THE SMALLER DIAMETER.

4. STANDARD HOOKS
BARS ENDING IN RIGHT ANGLE BENDS OR HOOKS SHALL CONFORM TO THE REQUIREMENTS OF THE BUILDING CODE.

5. SLOPING SLABS
MONOLITHIC SLABS WITH TOPS THAT ARE SLOPED SHALL HAVE BOTTOMS SLOPED THE SAME AMOUNT, MAINTAINING A UNIFORM SLAB THICKNESS, UNLESS OTHERWISE NOTED.

6. CHAMFERS
EXCEPT AS OTHERWISE NOTED, EXPOSED CONCRETE CORNERS AND EDGES SHALL HAVE 3/4" CHAMFERS. RE-ENTRANT CORNERS SHALL NOT HAVE FILLETS.

7. CONSTRUCTION JOINTS
ENGINEER APPROVAL IS REQUIRED FOR ANY CONSTRUCTION JOINTS NOT SHOWN ON THE DRAWINGS. CONSTRUCTION JOINTS SHALL BE DETAILED AS SHOWN ON THE DRAWINGS.

D. NON-SHRINK GROUT

GROUT FOR BASE PLATES, EQUIPMENT ANCHORAGE AND GENERAL PURPOSES SHALL BE APPROVED, NON-SHRINK CEMENTITIOUS GROUT CONTAINING NATURAL AGGREGATES DELIVERED TO THE JOB SITE IN FACTORY PREPACKAGED CONTAINERS REQUIRING ONLY THE ADDITION OF WATER, ASTM C1107 TYPE B OR C.

E. MASONRY

CONSTRUCTION SHALL MEET THE REQUIREMENTS OF THE BUILDING CODE. ALL HOLLOW CONCRETE MASONRY UNITS SHALL CONFORM TO ASTM C90. MEDIUM WEIGHT. MINIMUM REQUIRED BLOCK COMPRESSIVE STRENGTH IS 2,800 PSI. ALL CELLS CONTAINING REINFORCEMENT SHALL BE FILLED SOLID WITH CONCRETE GROUT. REMAINING CELLS SHALL BE FILLED WITH LOOSE GRANULAR INSULATION. GROUT MIX SHALL CONTAIN PORTLAND CEMENT ONLY, AGGREGATE, AND A GROUT-ENHANCING SHRINKAGE-COMPENSATING ADDITIVE. MAXIMUM SIZE OF AGGREGATE SHALL BE 3/8 INCH. SLUMP SHALL BE 8 TO 11 INCHES. WATER-REDUCING ADMIXTURES MAY BE USED. MINIMUM GROUT COMPRESSIVE STRENGTH BASED ON 28-DAY TESTS SHALL BE 2,000 PSI AND GREATER THAN OR EQUAL TO THE SPECIFIED MINIMUM DESIGN STRENGTH. GROUT SHALL BE VIBRATED WHILE PLACING TO ENSURE THAT CELLS ARE COMPLETELY FILLED. SUBMIT GROUT MIXES TO STRUCTURAL ENGINEER FOR REVIEW BEFORE COMMENCING MASONRY CONSTRUCTION. ALL UNITS SHALL BE LAID IN RUNNING BOND USING TYPE S MORTAR WITH HEAD JOINTS. MASONRY DESIGN STRENGTH IS fm = 2,000 PSI.

F. SUPPLEMENTAL MASONRY JOINT REINFORCING

1. DESCRIPTION: WELDED-WIRE UNITS PREFABRICATED WITH DEFORMED CONTINUOUS SIDE RODS AND PLAIN CROSS RODS INTO STRAIGHT LENGTHS OF NOT LESS THAN 10 FEET, WITH PREFABRICATED CORNER AND TEE UNITS, AND COMPLYING WITH REQUIREMENTS INDICATED BELOW:

A. WIRE DIAMETER FOR SIDE RODS: 0.1875 INCH.
B. WIRE DIAMETER FOR CROSS RODS: 0.1483 INCH (9 GAGE)

2. EXTERIOR WALLS:
STAINLESS STEEL WIRE, TYPE 304 COMPLYING WITH ASTM A 580.

3. INTERIOR WALLS:
GALVANIZED CARBON STEEL WIRE, COATING CLASS AS REQUIRED UNIT MASONRY STANDARD.

G. WOOD

1. FRAMING LUMBER

FRAMING LUMBER SHALL BE KILN DRIED OR MC-15, AND GRADED AND MARKED IN CONFORMANCE WITH WEST COAST LUMBER INSPECTION BUREAU STANDARD GRADING RULES FOR WEST COAST LUMBER NO. 16, LATEST EDITION. FURNISH TO THE FOLLOWING MINIMUM STANDARDS: UNLESS NOTED OTHERWISE.

2x JOISTS AND BUILT-UP MEMBERS HEM-FIR NO. 2

3x AND 4x BEAMS AND POSTS DOUGLAS FIR-LARCH NO. 2

TOP AND BOTTOM PLATES AT BEARING WALLS DOUGLAS FIR-LARCH CONSTRUCTION GRADE

BOLTED STUDS, LEDGERS AND PLATES DOUGLAS FIR-LARCH STANDARD GRADE

2. ROOF SHEATHING

PROVIDE 15/32 INCH-CDX-PLYWOOD, INDEX 32/16, BLOCKED, LAID UP WITH FACE GRAIN PERPENDICULAR TO FRAMING BELOW. STAGGER PANEL END JOINTS, PROVIDE APPROVED EDGE CLIPS AT 24 INCHES ON CENTER AT UNBLOCKED ROOF SHEATHING EDGES. PROVIDE 1/8-INCH GAP BETWEEN ALL ABUTTING PANEL EDGES. PROVIDE THE FOLLOWING MINIMUM NAILING UNLESS NOTED OTHERWISE ON PLANS:

10d AT 6 INCHES ON CENTER ALL SUPPORTED PANEL EDGES, DIAPHRAGM BOUNDARIES AND OVER EXTERIOR WALLS

10d AT 12 INCHES ON CENTER FIELD NAILING

3. TREATED WOOD

ALL WOOD PLATES, LEDGERS, AND BLOCKING IN DIRECT CONTACT WITH CONCRETE OR MASONRY SHALL BE PRESSURE-TREATED WITH AN AMERICAN WOOD PRESERVERS ASSOCIATION (AWPA) APPROVED PRESERVATIVE. ALTERNATIVELY PER IBC SECTION 2304.11, FOR SOME EXCEPTIONS, IMPERVIOUS MOISTURE BARRIERS MAY BE PROVIDED BETWEEN UNTREATED MEMBERS AND CONCRETE OR MASONRY.

ALL METAL FASTENERS IN CONTACT WITH TREATED WOOD SHALL BE GALVANIZED PER ASTM F2329 OR STAINLESS STEEL. WHEN USING GALVANIZED FASTENERS, THE CONTRACTOR SHALL VERIFY THE GALVANIZATION PROCESS WITH THE CHEMICAL COMPOSITION OF THE WOOD TREATMENT.

4. TIMBER CONNECTORS

TIMBER CONNECTORS CALLED OUT BY LETTERS AND NUMBERS SHALL BE BY SIMPSON STRONG-TIE COMPANY, INC, AS SPECIFIED IN THE LATEST EDITION OF THEIR CATALOG. EQUIVALENT DEVICES BY OTHER MANUFACTURERS MAY BE SUBSTITUTED, PROVIDED THEY HAVE CURRENT ICC-ES EVALUATION REPORTS DEMONSTRATING THAT THE PRODUCTS HAVE EQUAL OR GREATER LOAD CAPACITIES. PROVIDE NUMBER AND SIZE OF FASTENERS AS SPECIFIED BY MANUFACTURER. CONNECTORS SHALL BE INSTALLED IN ACCORDANCE WITH THE MANUFACTURER'S PUBLISHED SPECIFICATIONS. WHERE CONNECTOR STRAPS CONNECT TWO MEMBERS, PLACE ONE-HALF OF THE NAILS OR BOLTS IN EACH MEMBER. ALL BOLTS IN WOOD MEMBERS SHALL CONFORM TO ASTM A307. PROVIDE WASHERS UNDER THE HEADS AND NUTS OF ALL BOLTS AND LAG SCREWS BEARING ON WOOD. UNLESS NOTED OTHERWISE, ALL NAILS SHALL BE COMMON. ALL SHIMS SHALL BE SEASONED AND DRIED AND THE SAME GRADE (MINIMUM) AS MEMBERS CONNECTED. ALL SINGLE JOISTS, DOUBLE JOISTS, AND TRIPLE JOISTS SHALL BE CONNECTED TO FLUSH BEAMS WITH "U" SERIES JOIST HANGERS.

5. NAILS

A. NAILS SHALL BE GALVANIZED COMMON WIRE NAILS.

B. MINIMUM NAILING PER 2015 IBC TABLE 2304.10.1.

C. PRE DRILLED HOLES SHALL BE 1/16" LESS THAN SPIKE DIAMETER. WHERE SPLITTING OF WOOD MAY OCCUR, HOLES SHALL BE 1/32" LESS THAN NAIL DIAMETER AND DIAMETER OF NAIL LESS THAN THE PENETRATION OF THE NAIL.

6. WOOD FRAMING DETAILS

THE FOLLOWING APPLY UNLESS OTHERWISE SHOWN ON THE PLANS.

A. PLYWOOD WALL SHEATHING SHALL HAVE SOLID BLOCKING AT ALL EDGES. PROVIDE THE FOLLOWING MINIMUM NAILING UNLESS NOTED OTHERWISE ON PLANS:

8D AT 6 INCHES ON CENTER AT SHEET EDGES
8D AT 12 INCHES ON CENTER AT INTERMEDIATE BEARING POINTS

B. ALL MASONRY WALLS SHALL HAVE A DOUBLE TOP PLATE. WHERE BREAKS IN A PLATE OCCUR THEY SHALL BE LAPPED BY THE OTHER PLATE A MINIMUM OF 4'-0" AND NAILED TOGETHER WITH SIMPSON MSTA36.

Call 48 Hours Before You Dig

1-800-424-5555 UNDERGROUND SERVICE

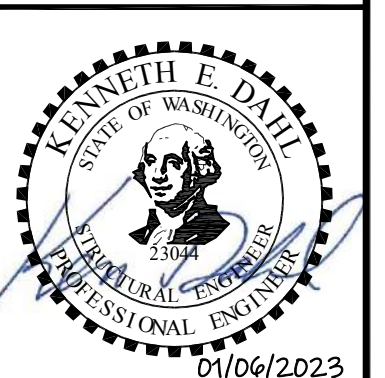

BHC Consultants, LLC
1601 Fifth Avenue, Suite 500
Seattle, Washington 98101
206.505.3400
206.505.3406 (fax)
www.bhcconsultants.com

Designed: K. Dahl, P.E., S.E.

Drawn: A. Bradley

Checked: T. Fisher, P.E.

Scale:

N/A

One Inch at Full Scale
If Not One Inch Scale Accordingly



Kitsap County Public Works

614 Division Street, MS 26
Port Orchard, WA 98366

SILVERDALE CONVEYANCE SYSTEM AND PUMP STATION 4 UPGRADES

SCHEDULE C

STRUCTURAL GENERAL NOTES

1 OF 2

Drawing: S-1C

Sheet: 59 of 117

File: P21-10530-PS4\_S-1C

Date: January 2023

**STRUCTURAL ABBREVIATIONS**

**H. PREFABRICATED WOOD TRUSSES**

THE CONTRACTOR IS RESPONSIBLE FOR THE DESIGN OF PREFABRICATED OPEN WEB WOOD TRUSSES (OR COMBINATION WOOD AND METAL). THESE MEMBERS SHALL BE DESIGNED FOR THE SPANS AND CONDITIONS SHOW ON THE PLANS AND SHALL BE FURNISHED AND INSTALLED IN CONFORMANCE WITH THE MANUFACTURER'S PUBLISHED SPECIFICATIONS. ALL NECESSARY BRACING, BRIDGING, BLOCKING, PRE-NOTCHED PLATES, ETC, SHALL BE DETAILED AND FURNISHED BY THE CONTRACTOR.

THE FOLLOWING TRUSS LOADING IS TYPICAL UNLESS NOTED OTHERWISE ON PLANS AND/OR LOAD MAPS.

TOP CHORD LIVE LOAD (SNOW) 25 PSF  
TOP CHORD DEAD LOAD 15 PSF

BOTTOM CHORD DEAD LOAD 10 PSF OR 2-200 LB. POINT LOADS APPLIED AT JOINTS, WHICHEVER IS LARGER.

ROOF TRUSSES SUPPORTING SNOW LOADS SHALL BE DESIGNED TO RESIST THE STRUCTURAL FORCES SET FORTH IN SECTION 1608 OF THE IBC. ROOF TRUSS DEFLECTION SHALL MEET THE MINIMUM IBC REQUIREMENTS UNLESS A MORE STRINGENT CRITERIA IS NOTED ON THE PLANS.

FLOOR LIVE LOAD DEFLECTION SHALL BE A MAXIMUM OF L/480, AND TOTAL LOAD DEFLECTION SHALL BE A MAXIMUM OF L/240, WHERE "L" IS THE SPAN IN INCHES.

IF USED, THE CONTRACTOR IS RESPONSIBLE FOR THE DESIGN OF PREFABRICATED CONNECTOR PLATE WOOD ROOF TRUSSES. THESE MEMBERS SHALL BE DESIGNED BY THE MANUFACTURER IN ACCORDANCE WITH ANSITPI 1, "NATIONAL DESIGN STANDARD FOR METAL PLATE CONNECTED WOOD TRUSS CONSTRUCTION." UTILIZE APPROVED CONNECTOR PLATES (GANGNAIL OR APPROVED EQUAL).

SUBMIT SHOP DRAWINGS AND DESIGN CALCULATIONS (COMPLETE WITH STRESS DIAGRAMS) TO THE ARCHITECT AND STRUCTURAL ENGINEER FOR REVIEW A MINIMUM OF TWO WEEKS PRIOR TO FABRICATION. SUBMITTED DOCUMENTS SHALL BEAR THE STAMP AND SIGNATURE OF AN ENGINEER LICENSED TO PERFORM THE WORK IN THE JURISDICTION WHERE THE PROJECT IS LOCATED.

PERMANENT AND TEMPORARY BRIDGING AND BRACING SHALL BE INSTALLED IN CONFORMANCE WITH MANUFACTURER'S PUBLISHED SPECIFICATIONS REQUIREMENTS

**I. METAL ROOF PANELS**

PROVIDE WEATHERTIGHT PREFORMED METAL ROOF PANELS. PANEL PROFILE SHALL BE AEP DESIGN SPAN HP,16" WIDE COVERAGE OR APPROVED EQUIVALENT. PANELS SHALL BE MANUFACTURED FROM 22 GA MINIMUM PER ASTM A792, GRADE 50, STEEL. PROVIDE PROTECTIVE COATINGS PER ASTM A792. ATTACH PANELS TO FRAMING PER MANUFACTURER REQUIREMENTS TO RESIST UL 90 UPLIFT LOADING. PROVIDE A COMPLETE WATERPROOF SYSTEM INCLUDING REQUIRED FLASHING, END STOPS, AND OTHER ACCESSORIES.

**J. FOUNDATION PREPARATION**

FOUNDATIONS, UNLESS NOTED OTHERWISE IN THE GEOTECHNICAL REPORT, SHALL BEAR ON UNDISTURBED, DENSE ALLUVIAL SOIL. IF UNDISTURBED, DENSE ALLUVIAL SOIL IS NOT FOUND AT THE BOTTOM OF THE FOOTING ELEVATION. WEAK MATERIAL SHALL BE REMOVED AND REPLACED WITH COMPACTED BACKFILL IN ACCORDANCE WITH THE SPECIFICATIONS. PROVIDE GRADED CRUSHED OR NATURAL ROCK BASE COURSE BENEATH CONCRETE SLABS OR FOOTINGS WHERE INDICATED.

BACKFILL SHALL BE COMPACTED TO 95% OF MAXIMUM DENSITY USING ASTM D1557.

**K. SPECIAL INSPECTION**

IN ADDITION TO THE INSPECTIONS REQUIRED BY SECTION 1701 OF THE IBC, SPECIAL INSPECTIONS SHALL BE PROVIDED DURING CONSTRUCTION OF THE FOLLOWING WORK:

1. ANCHOR BOLTS: INSTALLED IN CONCRETE OR MASONRY PRIOR TO AND DURING THE PLACEMENT OF CONCRETE AROUND BOLTS.
2. ALL MASONRY CONSTRUCTION: SHALL BE INSPECTED AND TESTED IN ACCORDANCE WITH LEVEL B REQUIREMENTS OF 2018 IBC PARAGRAPH 1705.4.
3. ALL CONCRETE: SHALL BE INSPECTED IN ACCORDANCE WITH REQUIREMENTS OF 2018 IBC PARAGRAPH 1705.3.
4. PLACEMENT: OF ALL REINFORCING STEEL SHALL BE INSPECTED.
5. ROOF SHEATHING NAILING AND CONNECTOR INSTALLATION.

**L. DEFERERED STRUCTURAL SUBMITTALS**

SOME STRUCTURAL SYSTEMS ARE DEFINED AS VENDOR-DESIGNED COMPONENTS PER STRUCTURAL DOCUMENTS. THE ELEMENTS OF DESIGN ARE DEFERRED SUBMITTAL COMPONENTS AND HAVE NOT BEEN PERMITTED UNDER THE BASE BUILDING APPLICATION. THE CONTRACTOR WILL BE REQUIRED TO SUBMIT THE STAMPED COMPONENT SYSTEM DOCUMENTS TO THE BUILDING OFFICIAL FOR APPROVAL.

DOCUMENTS FOR PREFERRED SUBMITTAL ITEMS SHALL BE SUBMITTED TO THE ENGINEER, WHO SHALL REVIEW THEM FOR GENERAL CONFORMANCE TO THE DESIGN OF THE BUILDING. THE CONTRACTOR SHALL SUBMIT THESE REVIEWED DEFERRED SUBMITTAL DOCUMENTS HAVE BEEN APPROVED BY THE BUILDING OFFICIAL.

THE FOLLOWING LIST INCLUDES THE ITEMS THAT ARE DEFINED AS DEFERRED STRUCTURAL SUBMITTAL COMPONENTS. REFER TO THE ARCHITECTURAL, MECHANICAL, ELECTRICAL, AND CIVIL DRAWINGS FOR ADDITIONAL DEFERRED SUBMITTAL COMPONENTS.

DEFERRED STRUCTURAL SUBMITTAL COMPONENTS:  
PREFABRICATED WOOD TRUSSES

**M. STRUCTURAL OBSERVATIONS**

THE ENGINEER OF RECORD SHALL PROVIDE VISUAL OBSERVATION OF THE STRUCTURAL SYSTEM, FOR GENERAL CONFORMANCE TO THE APPROVED PLANS AND SPECIFICATIONS, AT SIGNIFICANT CONSTRUCTION STAGES AND AT THE COMPLETION OF THE STRUCTURAL SYSTEM. STRUCTURAL OBSERVATION DOES NOT INCLUDE OR WAIVE THE RESPONSIBILITY FOR THE INSPECTIONS REQUIRED BY IBC SECTIONS 109, 1704 OR OTHER SECTIONS OF THE INTERNATIONAL BUILDING CODE. STRUCTURAL OBSERVATION REPORTS SHALL BE ISSUED TO THE OWNER, ARCHITECT, CONTRACTOR, AND BUILDING OFFICIAL AT THE SIGNIFICANT CONSTRUCTION STAGES.

Path: S:\Cadd\Kitsap County\21-10530 Silverdale Conveyance-PS-4 Upgr\Design\Drawings\21-10530\_S-2C.dwg; PLOT DATE: 01/06/2023 10:30:58am; CAD USER: JLF;a; Xref Filename: \X21-10530-PS4\_TB | Fisher | Dahl | Palmatier |

Call 48 Hours Before You Dig

1-800-424-5555  
UNDERGROUND SERVICE

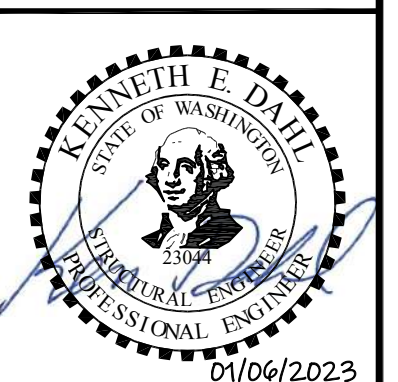

**BHC Consultants, LLC**  
1601 Fifth Avenue, Suite 500  
Seattle, Washington 98101  
206.505.3400  
206.505.3406 (fax)  
www.bhcconsultants.com

Designed: K. Dahl, P.E., S.E.

Drawn: A. Bradley

Checked: T. Fisher, P.E.

Scale:

N/A

One Inch at Full Scale

If Not One Inch Scale Accordingly



**Kitsap County Public Works**

614 Division Street, MS 26  
Port Orchard, WA 98366

**SILVERDALE CONVEYANCE SYSTEM AND PUMP STATION 4 UPGRADES  
SCHEDULE C**

**STRUCTURAL GENERAL NOTES  
2 OF 2**

Drawing: **S-2C**

Sheet: **60** of **117**

File: P21-10530\_S-2C

Date: January 2023

**STRUCTURAL ABBREVIATIONS**

@	AT	GA	GAGE	SIM	SIMILAR
AB	ANCHOR BOLT	GALV	GALVANIZED	SL	SLOPE
ACI	AMERICAN CONCRETE INSTITUTE	GL	GLUE LAMINATED LUMBER	SOG	SLAB ON GRADE
AISC	AMERICAN INSTITUTE OF STEEL CONSTRUCTION	GLULAM	GLUE LAMINATED BEAM	SP	SPACE
AITC	AMERICAN INSTITUTE OF TIMBER CONSTRUCTION	GWB	GYPSUM WALL BOARD	SPEC	SPECIFICATIONS
AL	ALUMINUM			SQ	SQUARE
ALT	ALTERNATE	HORIZ or H	HORIZONTAL	SQ IN	SQUARE INCH
ANSI	AMERICAN NATIONAL STANDARD INSTITUTE	HT	HEIGHT	SST	STAINLESS STEEL
APPROX	APPROXIMATE ARCH ARCHITECTURAL			STIR	STIRRUP
ARCH	ARCHITECT	IBC	INTERNATIONAL BUILDING CODE	STD	STANDARD
ASCE	AMERICAN SOCIETY OF CIVIL ENGINEERS	ID	INSIDE DIAMETER	STL	STEEL
ASTM	AMERICAN SOCIETY FOR TESTING AND MATERIALS	IF	INSIDE FACE	STR	STRUCTURAL
AWPA	AMERICAN WOOD PRESERVERS ASSOCIATION	IN or "	INCH	SYM	SYMMETRY
AWS	AMERICAN WELDING SOCIETY				
		JST	JOIST	T&B	TOP AND BOTTOM
BLDG	BUILDING	JT	JOINT	TEMP	TEMPORARY
BM	BEAM			TOC	TOP OF CONCRETE
BOT	BOTTOM	K	KIP	TOF	TOP OF FOOTING
BP	BASE PLATE	KSF	KIPS PER SQUARE FEET	TOM	TOP OF MASONRY
BR	BRICK			TOS	TOP OF STEEL, TOP OF SLAB
BRG	BEARING	L	LENGTH or METAL ANGLE	TOW	TOP OF WALL
		LBS	POUNDS		
CB	CORNER BAR	LF	LINEAR FEET	TPI	TRUSS PLATE INSTITUTE
CC	CENTER TO CENTER	LLV	LONG LEG VERTICAL	TRANS	TRANSVERSE
CF	CUBIC FEET	LONGIT	LONGITUDINAL	TYP	TYPICAL
CFS	COLD FORMED STEEL	LSL	TIMBERSTRAND RIM BOARD		
CIP	CAST-IN-PLACE	LVL	LAMINATED VENEER LUMBER	UNO	UNLESS NOTED OTHERWISE
CJ	CONSTRUCTION JOINT				
C/L	CENTER LINE	MAX	MAXIMUM	VAR	VARIES
CLR	CLEARANCE, CLEAR	MECH	MECHANICAL	VERT OR V	VERTICAL
CLSM	CONTROLLED LOW STRENGTH MATERIAL	MFR	MANUFACTURER		
CNR	CORNER	MIN	MINIMUM	W	WEST, WIDTH
CMU	CONCRETE MASONRY UNIT	MISC	MISCELLANEOUS	W/	WITH
COL	COLUMN	MO	MASONRY OPENING	W/O	WITHOUT
CONC	CONCRETE	MPH	MILES PER HOUR	WHS	WELDED HEADED STUD
CONN	CONNECTION			WP	WORK POINT
CONT	CONTINUOUS	N	NORTH	WSDOT	WASHINGTON STATE DEPARTMENT OF
CPLG	COUPLING	N/A	NOT APPLICABLE		TRANSPORTATION
CTR	CENTER	NIC	NOT IN CONTRACT	WWR	WELDED WIRE REINFORCEMENT
		NO.	or # NUMBER		
DBA	DEFORMED BAR ANCHOR	NOM	NOMINAL		
DEG or °	DEGREES	NS	NEAR SIDE		
DI	DUCTILE IRON	NTS	NOT TO SCALE		
DIA OR Ø	DIAMETER				
DWG	DRAWING	OC	ON CENTER		
		OD	OUTSIDE DIAMETER		
EA	EACH	OF	OUTSIDE FACE		
EF	EACH FACE	OPNG	OPENING		
EJ	EXPANSION JOINT	OPP	OPPOSITE		
EL, ELEV	ELEVATION				
ELEC	ELECTRICAL	PC	PRECAST		
EMBED	EMBEDMENT	PCF	POUNDS PER CUBIC FOOT		
EQ	EQUAL	PERF	PERFORATED		
ES	EACH SIDE	PJF	PREFORMED JOINT FILLER		
EW	EACH WAY	PL	PLATE		
EX	EXISTING	PS	PRESTRESSING TENDON		
		PSF	POUNDS PER SQUARE FOOT		
FAB	FABRICATION	PSI	POUNDS PER SQUARE INCH		
FB	FLAT BAR	PSL	PARALLEL STRESSED LUMBER		
FIN	FINISH	PT	PRESSURE TREATED, POST TENSIONED		
FF	FINISHED FLOOR				
FLR	FLOOR	R	RADIUS		
FS	FAR SIDE	REINF	REINFORCEMENT		
FT or '	FOOT or FEET	RO	ROUGH OPENING		
FTG	FOOTING				
fy	YIELD STRESS				

**Call 48 Hours Before You Dig**  
**1-800-424-5555**  
 UNDERGROUND SERVICE



Path: S:\Cadd\Kitsap County\21-10530 Silverdale Convey-PS-4 Upgr\Design\Drawings\21-10530-S-3C PS4\_TB.dwg  
 Xref Filename: 21-10530-PS4\_TB | Fisher | Dahl | Palmatier |  
 File Name: 21-10530-S-3C PS4\_TB.dwg  
 PLOT Date: Jan 06, 2023 - 10:35:50am  
 CAD User: JLD

ISSUED FOR BID	01-2023	TF	RAD
No.	Revision	Date	By App'd

**bhc**  
**CONSULTANTS**

**BHC Consultants, LLC**  
 1601 Fifth Avenue, Suite 500  
 Seattle, Washington 98101  
 206.505.3400  
 206.505.3406 (fax)  
 www.bhcconsultants.com

Designed: K. Dahl, P.E., S.E.	Scale: N/A
Drawn: A. Bradley	One Inch at Full Scale If Not One Inch Scale Accordingly
Checked: T. Fisher, P.E.	

**Kitsap County Public Works**  
 614 Division Street, MS 26  
 Port Orchard, WA 98366

**SILVERDALE CONVEYANCE SYSTEM AND PUMP STATION 4 UPGRADES SCHEDULE C**

**STRUCTURAL ABBREVIATIONS**

Drawing: <b>S-3C</b>
Sheet: <b>61</b> of <b>117</b>
File: P21-10530-PS4_S-3C
Date: January 2023

Path: S:\Cadd\Kitsap County\21-10530 Silverdale Convey-PS 4 Uprgr\Design\Drawings\21-10530-S-4C\_Prop\_FTC.dwg, P21-10530-S-4C\_Prop\_FTC.dwg, Jan 06, 2023, 10:37:24am CAD User: J.Lira  
 Xref Filename: | X21-10530-PS4\_TB | Fisher | X21-10530-PS4\_Ex Bldg | Dahl | X21-10530-PS4\_Prop FTC | X21-10530-PS4\_Prop Grid | Palmatier |

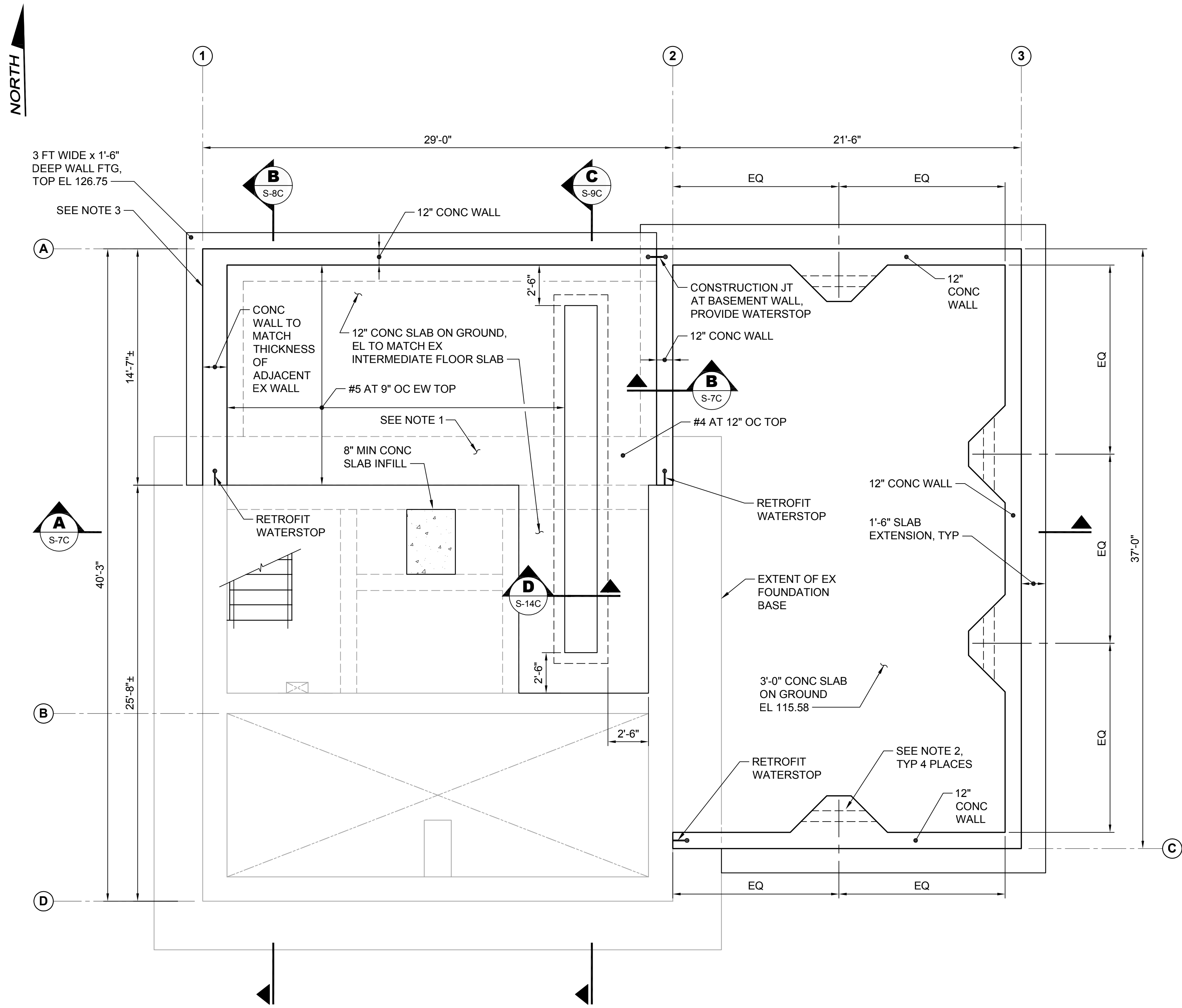

**NOTES:**

1. NEW FLOOR ELEVATION TO MATCH EXISTING FLOOR ELEVATION. APPROXIMATE ELEVATION IS 128.25. FIELD VERIFY.
2. PROVIDE PVC PIPE SLEEVE TO MATCH CENTERLINE OF INCOMING PIPE. INSIDE DIAMETER OF SLEEVE SHALL BE 1 INCH LARGER THAN OUTSIDE OF INCOMING PIPE.
3. REINFORCE WALL ALONG GRID 1 SAME AS SPECIFIED FOR WALL ALONG GRID A BETWEEN GRIDS 1 AND 2.

**Call 48 Hours Before You Dig**

**1-800-424-5555**  
UNDERGROUND SERVICE

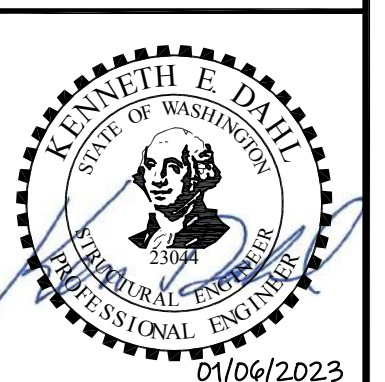

No.	Revision	Date	By	App'd
	ISSUED FOR BID	01-2023	TF	RAD



**BHC Consultants, LLC**  
 1601 Fifth Avenue, Suite 500  
 Seattle, Washington 98101  
 206.505.3400  
 206.505.3406 (fax)  
 www.bhcconsultants.com

Designed: K. Dahl, P.E., S.E.  
 Drawn: A. Bradley  
 Checked: T. Fisher, P.E.

Scale:  
 1/4" = 1'-0"  
 One Inch at Full Scale  
 If Not One Inch Scale Accordingly



**Kitsap County Public Works**  
 614 Division Street, MS 26  
 Port Orchard, WA 98366

**SILVERDALE CONVEYANCE SYSTEM AND PUMP STATION 4 UPGRADES**  
**SCHEDULE C**  
**CONTROL BUILDING**  
**PIPING ROOM FLOOR AND FOUNDATION**  
**PLAN**

Drawing: **S-4C**  
 Sheet: **62** of **117**  
 File: P21-10530-PS4\_S-4C  
 Date: January 2023

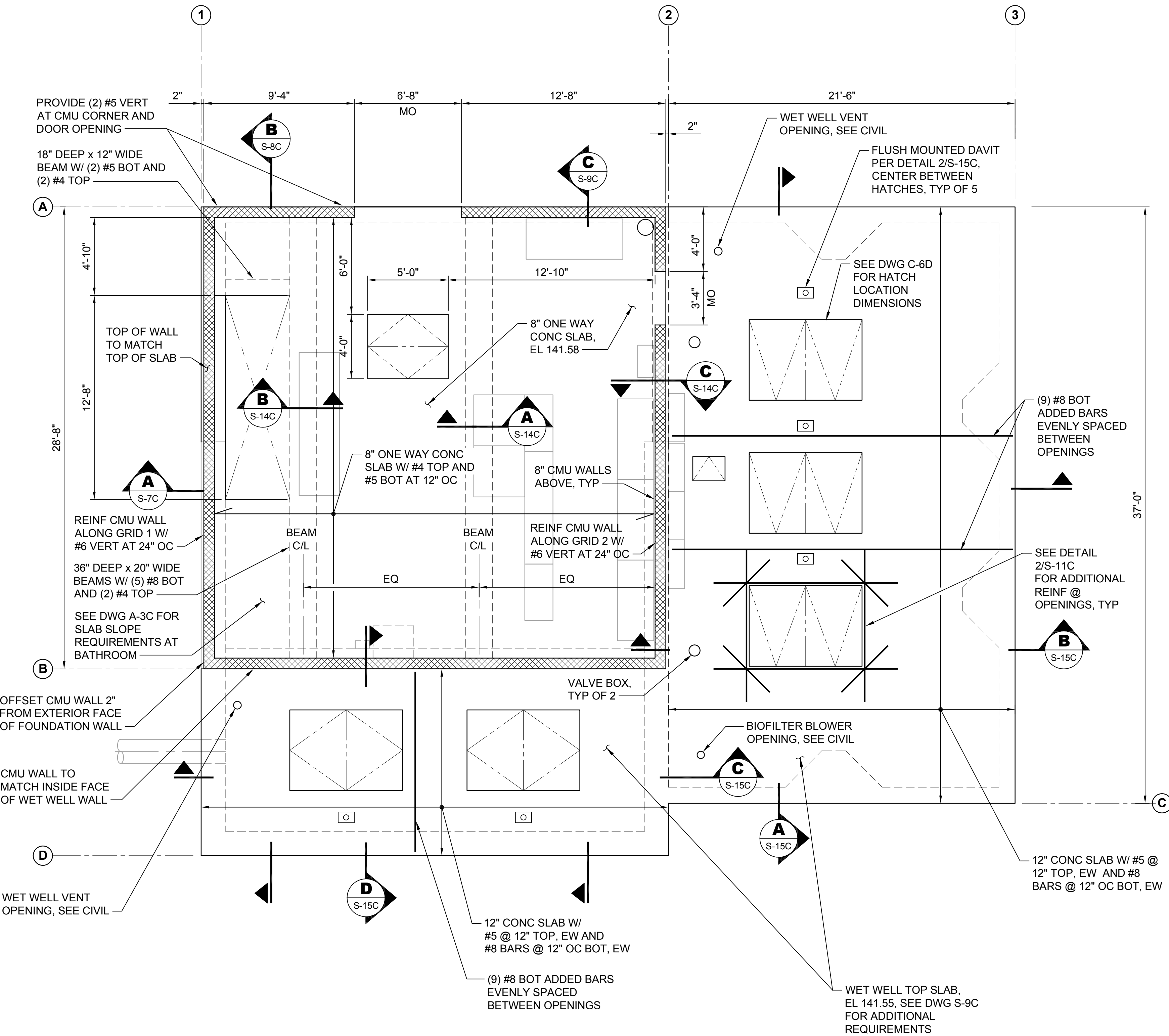
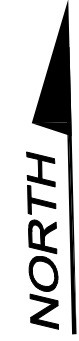

**NOTES:**

1. EXTERIOR CMU WALLS SHALL BE REINFORCED WITH #5 VERTS AT 24" OC CELLS WITHOUT REINFORCEMENT SHALL BE FILLED WITH VERMICULITE.
2. SEE CMU WALL TYPICAL DETAILS FOR HORIZONTAL AND OPENING REINFORCEMENT REQUIREMENTS.
3. TOP OF SLAB ELEVATION PER DWG C3-C.
4. SEE DWG C6-D FOR HATCH AND VALVE BOX LOCATIONS.

Path: S:\Cadd\Kitsap County\21-10530 Silverdale Convey-PS-4 UprgtDesign.d File: P21-10530\_S-5C Prop date: Jan 06, 2023 10:39:15am CAD User: JLFra  
 Xref File: X21-10530-PS4\_TB | X21-10530-PS4\_Ex Bldg | X21-10530-PS4\_Prop Mch | X21-10530-PS4\_Prop PFC | X21-10530-PS4\_Prop Elec | Fisher | Palmatier |

**Call 48 Hours Before You Dig**  
 1-800-424-5555  
 UNDERGROUND SERVICE

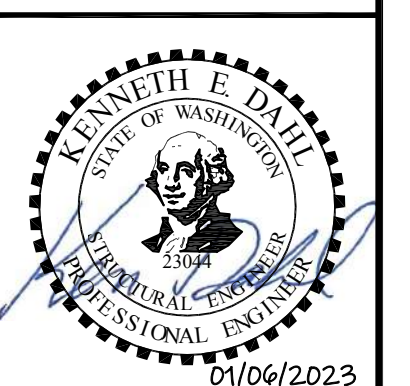

No.	Revision	Date	By	App'd
	ISSUED FOR BID	01-2023	TF	RAD

**bhc**  
**CONSULTANTS**  
**BHC Consultants, LLC**  
 1601 Fifth Avenue, Suite 500  
 Seattle, Washington 98101  
 206.505.3400  
 206.505.3406 (fax)  
 www.bhcconsultants.com

Designed: K. Dahl, P.E., S.E.  
 Drawn: S. Olsoe  
 Checked: T. Fisher, P.E.

Scale:  
 1/4" = 1'-0"  
 One Inch at Full Scale  
 If Not One Inch Scale Accordingly



**Kitsap County Public Works**  
 614 Division Street, MS 26  
 Port Orchard, WA 98366

**SILVERDALE CONVEYANCE SYSTEM AND PUMP STATION 4 UPGRADES**  
**SCHEDULE C**  
**CONTROL BUILDING**  
**ELECTRICAL ROOM AND WET WELL**  
**TOP SLAB FRAMING PLAN**

Drawing: **S-5C**  
 Sheet: **63** of **117**  
 File: P21-10530\_S-5C  
 Date: January 2023

NORTH

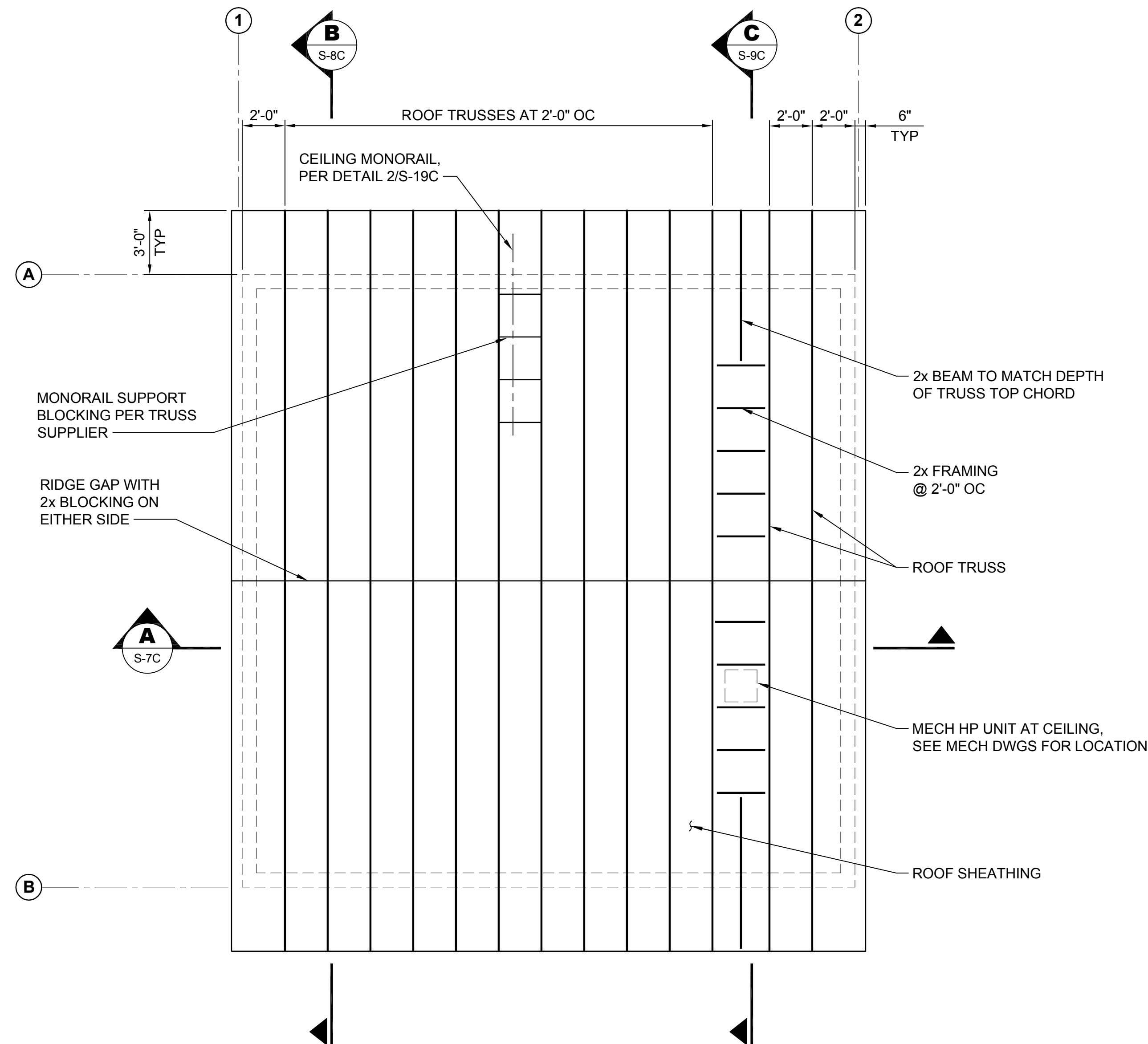

Path: S:\Cadd\Kitsap County\21-10530 Silverdale Convey-PS 4 Uprgt\Design\Drawings\21-10530\_S-6C\_Prop.dwg, P21-10530\_S-6C\_Prop.dwg, Jan 06, 2023, 10:54:27am CAD User: JLiRa  
 Xref Filename: \X21-10530-PS4\_TB | Fisher | Dahl | X21-10530-PS4\_Prop Bldg | X21-10530-PS4\_Prop Grid | Palmalter |

**Call 48 Hours Before You Dig**  
 1-800-424-5555  
 UNDERGROUND SERVICE

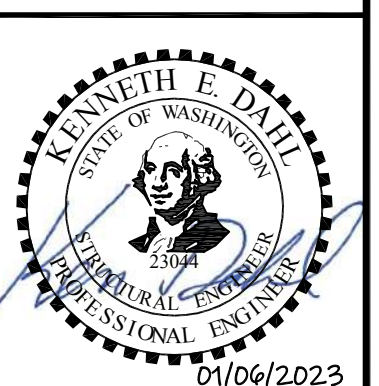

No.	Revision	Date	By	App'd
	ISSUED FOR BID	01-2023	TF	RAD

**bhc**  
 CONSULTANTS

**BHC Consultants, LLC**  
 1601 Fifth Avenue, Suite 500  
 Seattle, Washington 98101  
 206.505.3400  
 206.505.3406 (fax)  
 www.bhcconsultants.com

Designed: K. Dahl, P.E., S.E.  
 Drawn: A. Bradley  
 Checked: T. Fisher, P.E.

Scale:  
 1/4" = 1'-0"  
 One Inch at Full Scale  
 If Not One Inch Scale Accordingly



**Kitsap County Public Works**  
 614 Division Street, MS 26  
 Port Orchard, WA 98366

**SILVERDALE CONVEYANCE SYSTEM AND PUMP STATION 4 UPGRADES**  
 SCHEDULE C

**CONTROL BUILDING**  
**ROOF FRAMING PLAN**

Drawing: **S-6C**  
 Sheet: **64** of **117**  
 File: P21-10530\_S-6C  
 Date: January 2023



Path: S:\Cadd\Kitsap County\21-10530 Silverdale Conveyance PS 4 Upgr\Design\Drawings\21-10530\_S-7C\_Prop.dwg, Jan 06, 2023, 10:57:35am CAD User: J.Lira  
 Xref Filename: 21-10530-PS4\_TB | 21-10530-PS4\_Prop.dwg | 21-10530-PS4\_Ex.dwg | 21-10530-PS4\_Prop.dwg | 21-10530-PS4\_Prop.dwg | 21-10530-PS4\_Prop.dwg | 21-10530-PS4\_Prop.dwg

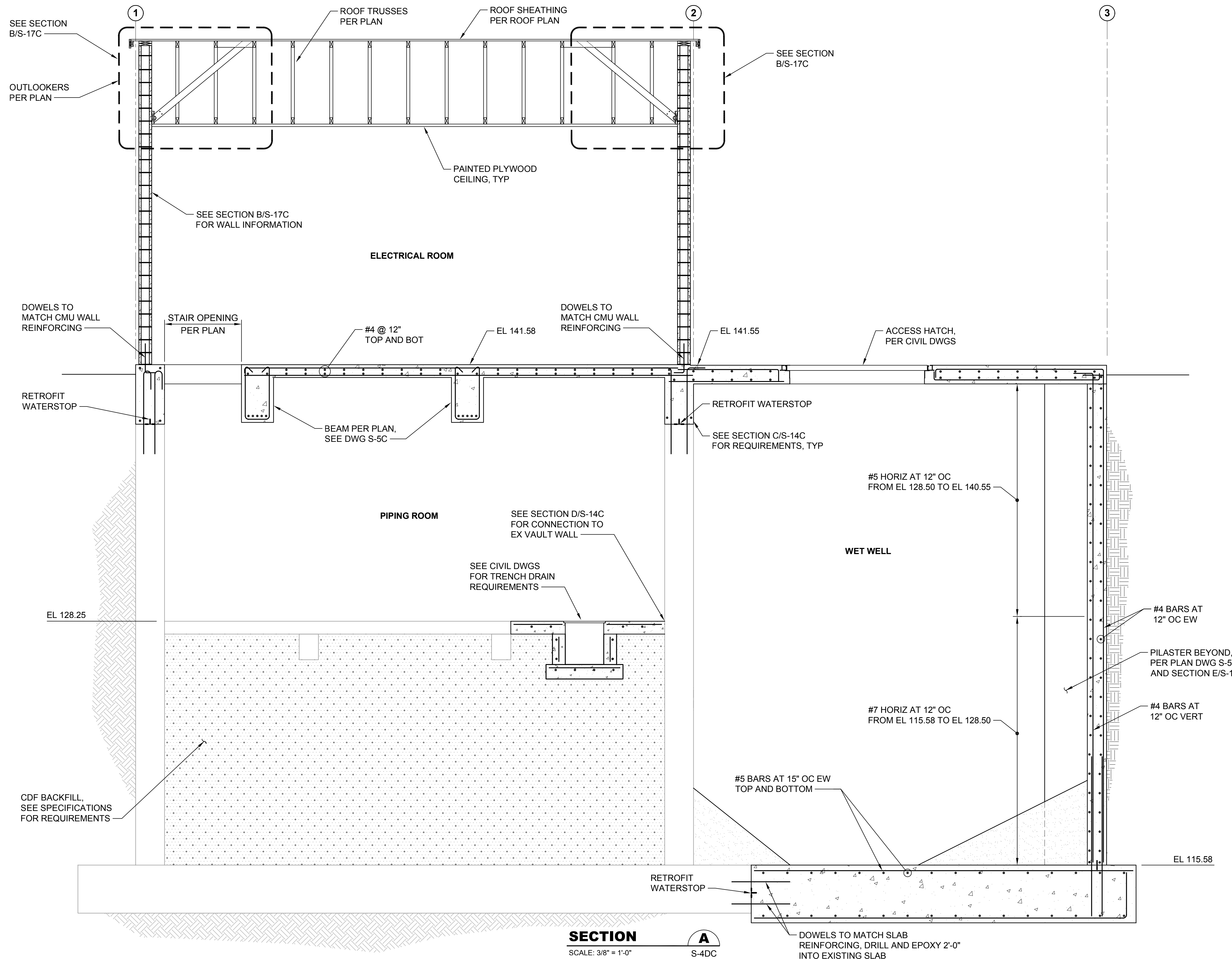

**SECTION A**  
SCALE: 3/8" = 1'-0"  
S-4DC

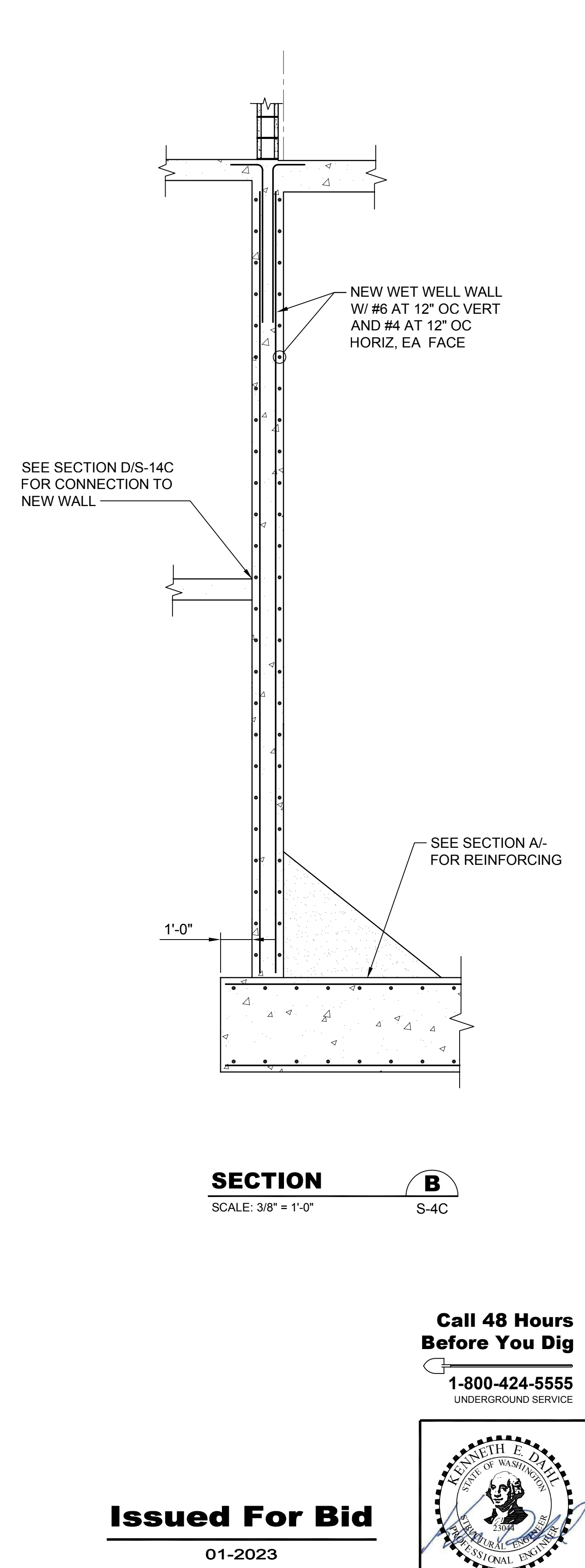

**SECTION B**  
SCALE: 3/8" = 1'-0"  
S-4C

**Call 48 Hours Before You Dig**  
 1-800-424-5555  
 UNDERGROUND SERVICE



**Issued For Bid**  
01-2023

No.	Revision	Date	By	App'd
	ISSUED FOR BID	01-2023	TF	RAD

**bhc**  
CONSULTANTS

**BHC Consultants, LLC**  
1601 Fifth Avenue, Suite 500  
Seattle, Washington 98101  
206.505.3400  
206.505.3406 (fax)  
www.bhcconsultants.com

Designed: K. Dahl, P.E., S.E.  
 Drawn: P. Simon  
 Checked: T. Fisher, P.E.

Scale:  
3/8" = 1'-0"  
One Inch at Full Scale  
If Not One Inch Scale Accordingly



**Kitsap County Public Works**  
614 Division Street, MS 26  
Port Orchard, WA 98366

**SILVERDALE CONVEYANCE SYSTEM AND PUMP STATION 4 UPGRADES**  
SCHEDULE C  
**CONTROL BUILDING SECTIONS**  
1 OF 3

Drawing: **S-7C**  
 Sheet: **65** of **117**  
 File: P21-10530\_S-7C  
 Date: January 2023

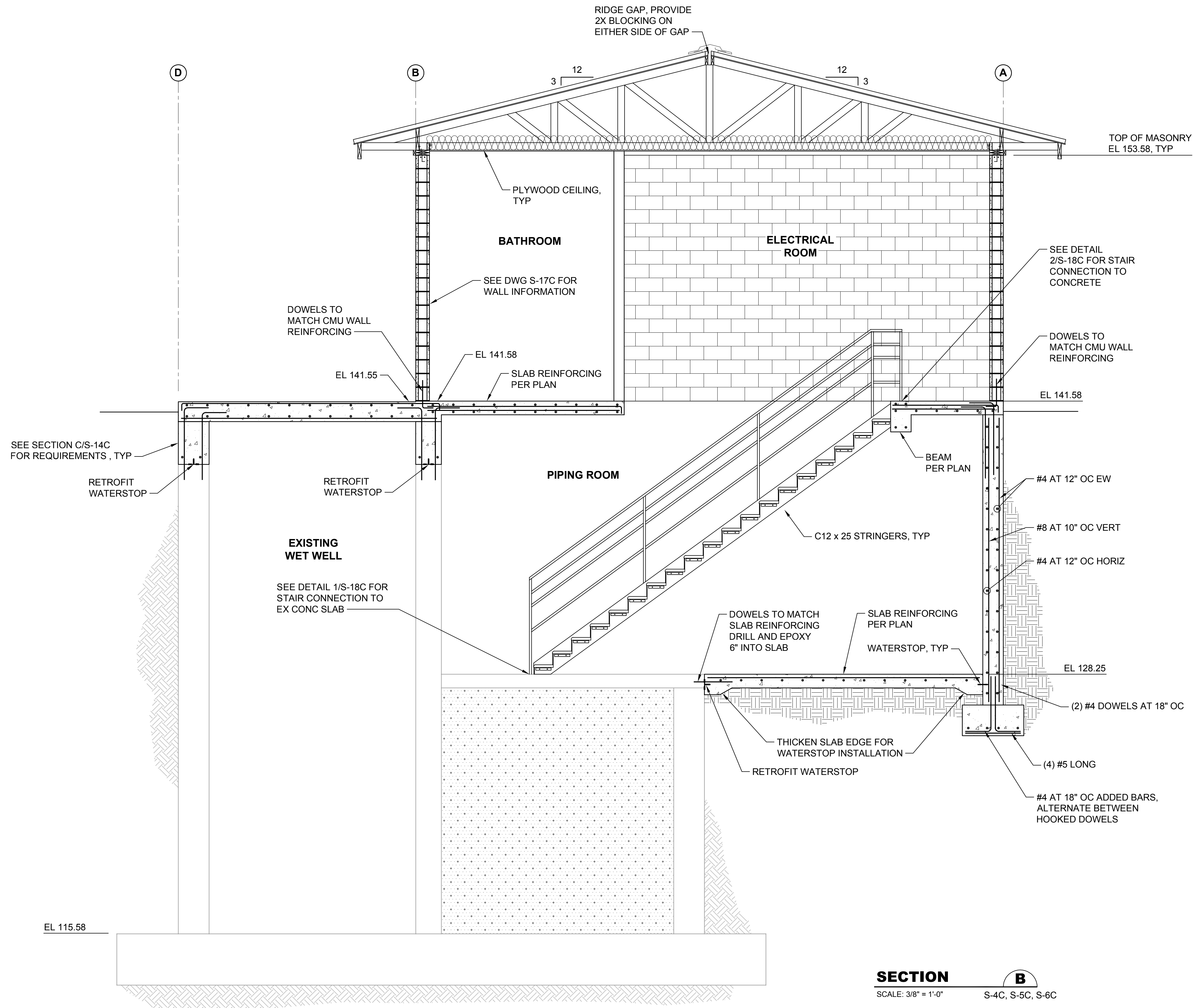

**SECTION B**  
SCALE: 3/8" = 1'-0" S-4C, S-5C, S-6C

**Call 48 Hours Before You Dig**  
1-800-424-5555  
UNDERGROUND SERVICE

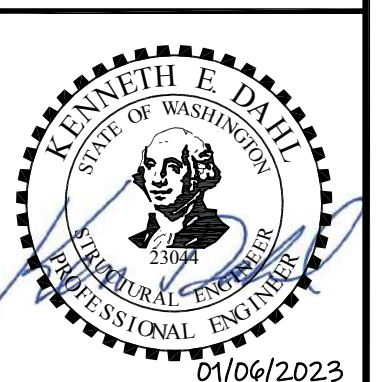

Path: S:\Cad\Kitsap County\21-10530 Silverdale Convey-PS-4 Upgr\Design\Drawings\21-10530\_S-8C Prop date Jan 06, 2023-10:59:57am CAD User: JLiira  
Xref Filename: 21-10530-PS4\_TB | Dahl | 21-10530-PS4\_Prop Bldg | 21-10530-PS4\_Ext Bldg | 21-10530-PS4\_Prop Grd | Fisher | Palmalter |

No.	Revision	Date	By	App'd
	ISSUED FOR BID	01-2023	TF	RAD

**bhc CONSULTANTS**  
BHC Consultants, LLC  
1601 Fifth Avenue, Suite 500  
Seattle, Washington 98101  
206.505.3400  
206.505.3406 (fax)  
www.bhcconsultants.com

Designed: K. Dahl, P.E., S.E.  
Drawn: A. Bradley  
Checked: T. Fisher, P.E.

Scale:  
3/8" = 1'-0"  
One Inch at Full Scale  
If Not One Inch Scale Accordingly



**Kitsap County Public Works**  
614 Division Street, MS 26  
Port Orchard, WA 98366

**SILVERDALE CONVEYANCE SYSTEM AND PUMP STATION 4 UPGRADES SCHEDULE C**  
**CONTROL BUILDING SECTIONS**  
**2 OF 3**

Drawing: **S-8C**  
Sheet: **66** of **117**  
File: P21-10530\_S-8C  
Date: January 2023

Path: S:\CAD\Kitsap County\21-10530 Silverdale Convey-PS-4\Upgr\Design\Drawings\21-10530\_S-9C\_Prop.dwg, Jan 06, 2023, 11:02:39am CAD User: JLi,ra  
 Xref Filename: 21-10530-PS-4\_TB | Fisher | Dahl | 21-10530-PS-4\_Prop Bldg | 21-10530-PS-4\_Ex Bldg | 21-10530-PS-4\_Prop Grid | Palmalter |

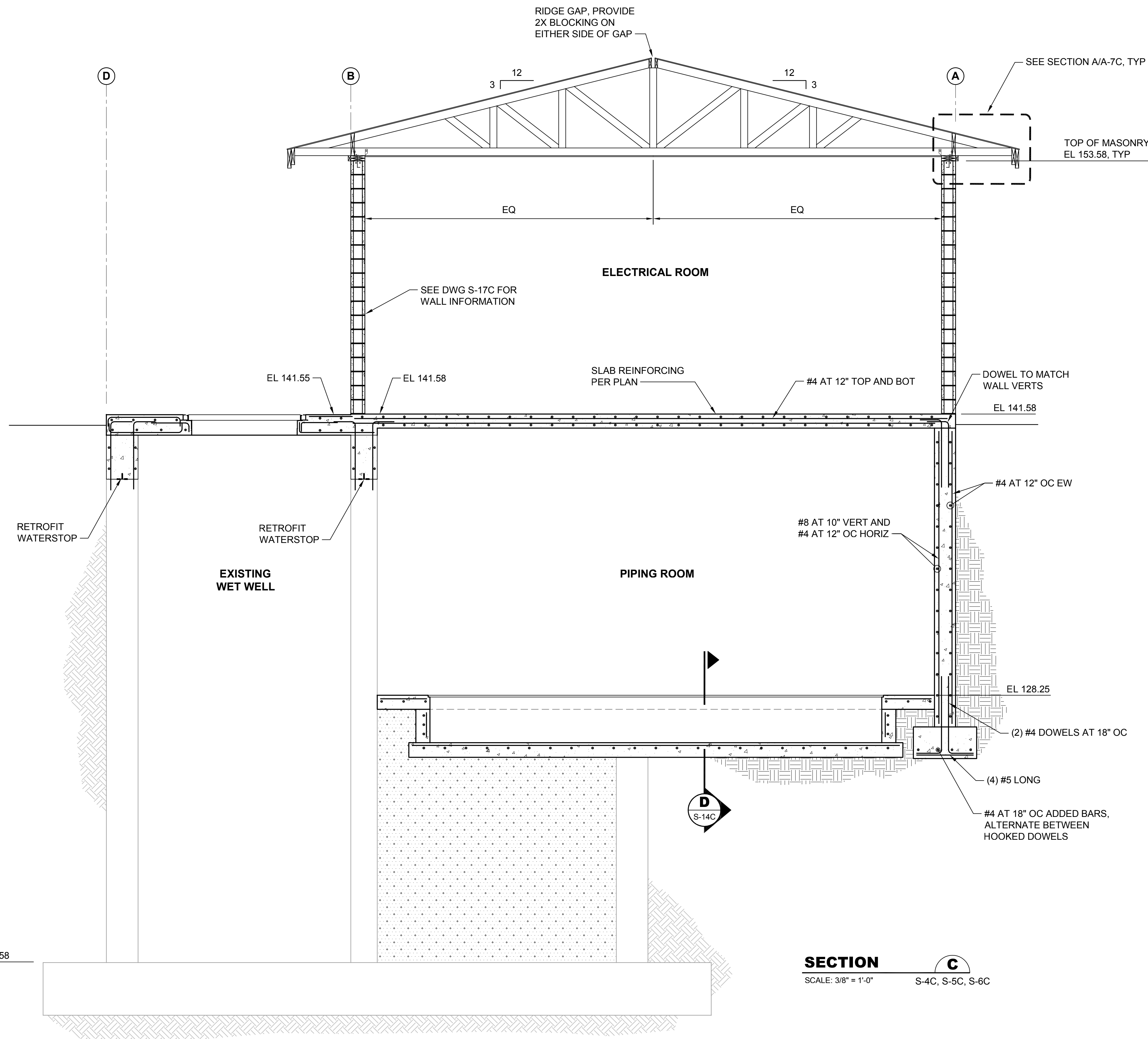

**SECTION C**  
 SCALE: 3/8" = 1'-0" S-4C, S-5C, S-6C

**Call 48 Hours Before You Dig**  
 1-800-424-5555  
 UNDERGROUND SERVICE



No.	Revision	Date	By	App'd
	ISSUED FOR BID	01-2023	TF	RAD



**BHC Consultants, LLC**  
 1601 Fifth Avenue, Suite 500  
 Seattle, Washington 98101  
 206.505.3400  
 206.505.3406 (fax)  
 www.bhcconsultants.com

Designed: K. Dahl, P.E., S.E.  
 Drawn: P. Simon  
 Checked: T. Fisher, P.E.

Scale:  
 3/8" = 1'-0"  
 One Inch at Full Scale  
 If Not One Inch Scale Accordingly



**Kitsap County Public Works**  
 614 Division Street, MS 26  
 Port Orchard, WA 98366

**SILVERDALE CONVEYANCE SYSTEM AND PUMP STATION 4 UPGRADES**  
 SCHEDULE C  
**CONTROL BUILDING SECTIONS**  
**3 OF 3**

Drawing: **S-9C**  
 Sheet: **67** of **117**  
 File: P21-10530\_S-9C  
 Date: January 2023

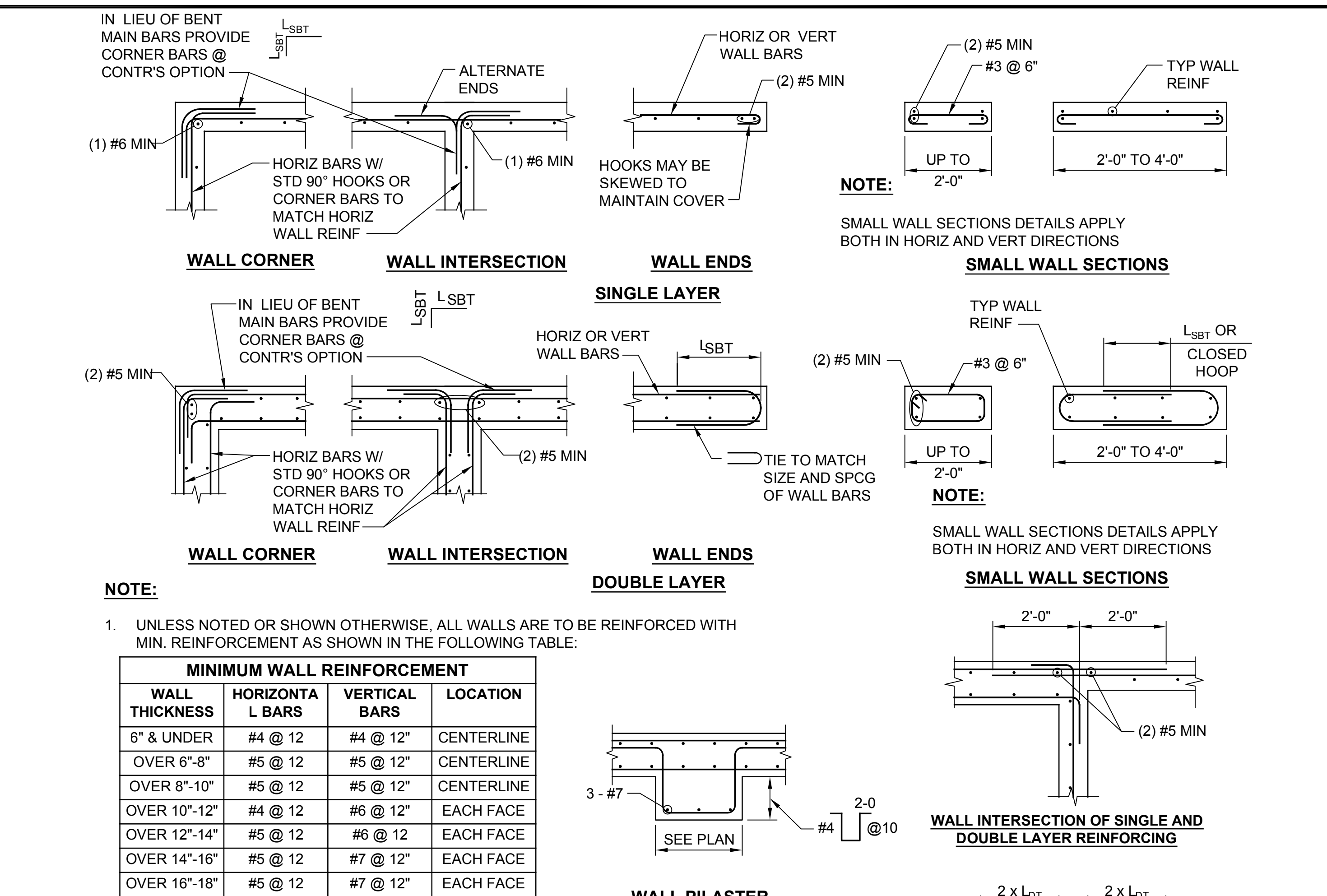
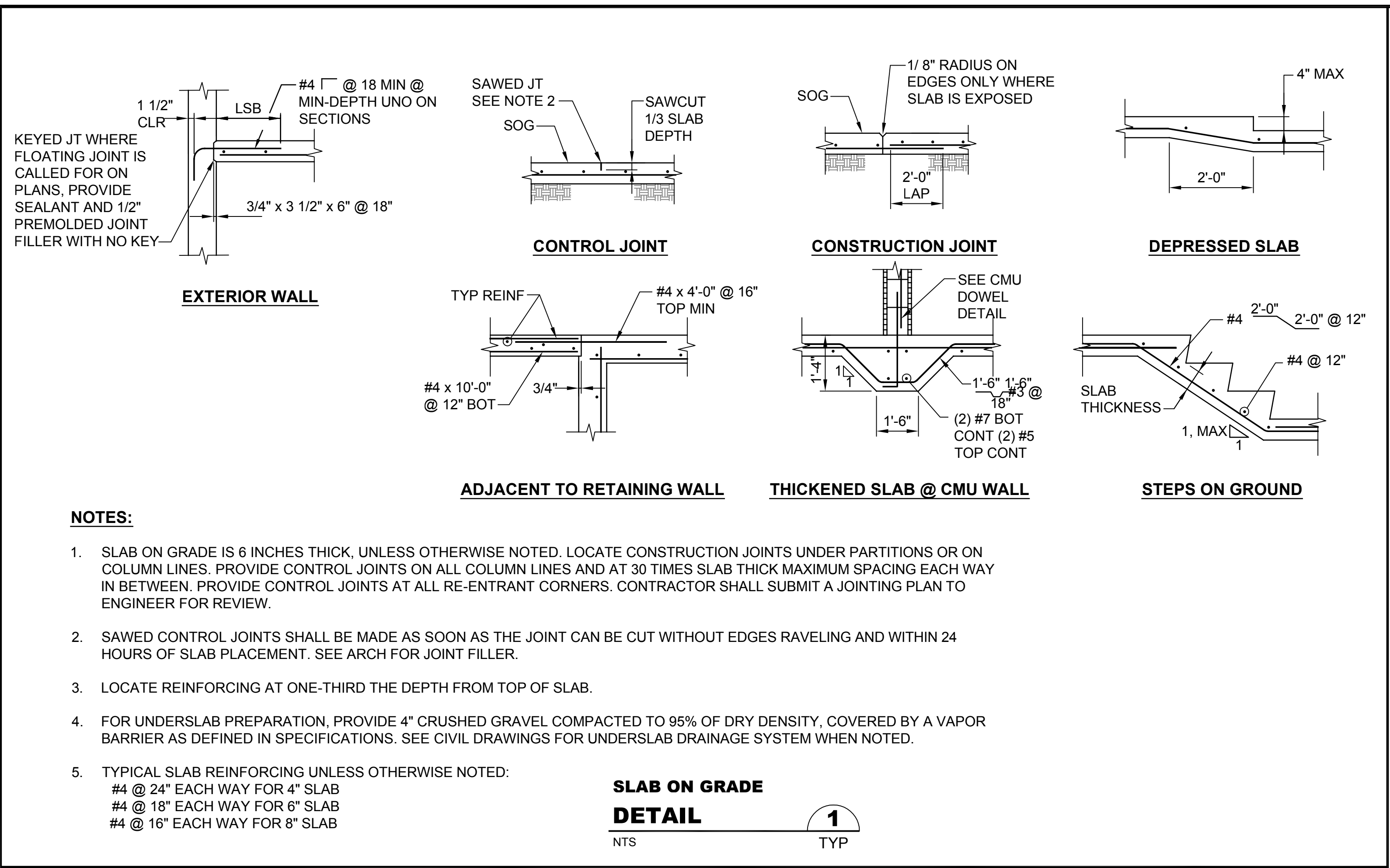

- NOTES:**
- SLAB ON GRADE IS 6 INCHES THICK, UNLESS OTHERWISE NOTED. LOCATE CONSTRUCTION JOINTS UNDER PARTITIONS OR ON COLUMN LINES. PROVIDE CONTROL JOINTS ON ALL COLUMN LINES AND AT 30 TIMES SLAB THICK MAXIMUM SPACING EACH WAY IN BETWEEN. PROVIDE CONTROL JOINTS AT ALL RE-ENTRANT CORNERS. CONTRACTOR SHALL SUBMIT A JOINTING PLAN TO ENGINEER FOR REVIEW.
  - SAWED CONTROL JOINTS SHALL BE MADE AS SOON AS THE JOINT CAN BE CUT WITHOUT EDGES RAVELING AND WITHIN 24 HOURS OF SLAB PLACEMENT. SEE ARCH FOR JOINT FILLER.
  - LOCATE REINFORCING AT ONE-THIRD THE DEPTH FROM TOP OF SLAB.
  - FOR UNDERSLAB PREPARATION, PROVIDE 4" CRUSHED GRAVEL COMPACTED TO 95% OF DRY DENSITY, COVERED BY A VAPOR BARRIER AS DEFINED IN SPECIFICATIONS. SEE CIVIL DRAWINGS FOR UNDERSLAB DRAINAGE SYSTEM WHEN NOTED.
  - TYPICAL SLAB REINFORCING UNLESS OTHERWISE NOTED:  
#4 @ 24" EACH WAY FOR 4" SLAB  
#4 @ 18" EACH WAY FOR 6" SLAB  
#4 @ 16" EACH WAY FOR 8" SLAB



- NOTE:**
- UNLESS NOTED OR SHOWN OTHERWISE, ALL WALLS ARE TO BE REINFORCED WITH MIN. REINFORCEMENT AS SHOWN IN THE FOLLOWING TABLE:

MINIMUM WALL REINFORCEMENT			
WALL THICKNESS	HORIZONTAL BARS	VERTICAL BARS	LOCATION
6" & UNDER	#4 @ 12	#4 @ 12"	CENTERLINE
OVER 6"-8"	#5 @ 12	#5 @ 12"	CENTERLINE
OVER 8"-10"	#5 @ 12	#5 @ 12"	CENTERLINE
OVER 10"-12"	#4 @ 12	#6 @ 12"	EACH FACE
OVER 12"-14"	#5 @ 12	#6 @ 12"	EACH FACE
OVER 14"-16"	#5 @ 12	#7 @ 12"	EACH FACE
OVER 16"-18"	#5 @ 12	#7 @ 12"	EACH FACE
OVER 18"-20"	#5 @ 12	#8 @ 12"	EACH FACE
OVER 20"-24"	#5 @ 12	#8 @ 12"	EACH FACE

- LAP WALL REINFORCING AT SPLICES L<sub>SB(G)</sub> SEE NOTE 5.
- ALL VERTICAL REINFORCING IN CONCRETE WALLS SHALL BE CONTINUOUS FROM STRUCTURAL FLOOR TO STRUCTURAL FLOOR, OR FROM FOOTING TO FIRST STRUCTURAL FLOOR ABOVE, UNLESS NOTED OTHERWISE.
- START HORIZONTAL AND VERTICAL BARS 1 INCH CLEAR OF EDGE OF OPENINGS. SPACE REINFORCING BARS AT EQUAL SPACES NOT TO EXCEED REQUIRED SPACING.
- REFER TO 3/- FOR VALUES OF L<sub>D</sub>, L<sub>SB</sub>, AND L<sub>SBG</sub>. LENGTHS SHOWN AS L<sub>SB(G)</sub> SHALL BE EITHER L<sub>SB</sub> OR L<sub>SBG</sub> DEPENDING ON BAR SPACING.
- SEE DETAIL 2/S-11C FOR OPENING REINFORCEMENT.



BAR SIZE	L <sub>D</sub>	L <sub>DT</sub>	L <sub>SB</sub>	L <sub>SBT</sub>	L <sub>B</sub>
3	14	18	18	24	8
4	19	25	25	32	10
5	24	31	31	40	12
6	28	37	37	48	14
7	42	54	54	70	17
8	47	62	62	80	19
9	54	70	70	90	22
10	60	78	78	102	24
11	67	87	87	113	26

- NOTES:**
- LENGTHS EXPRESSED IN INCHES.
  - LENGTHS APPLICABLE FOR f<sub>c</sub> = 4000 psi, NORMAL WEIGHT CONCRETE ONLY, AND REINFORCEMENT WITH f<sub>y</sub>=60,000 PSI
  - L<sub>D</sub> TENSION DEVELOPMENT LENGTH, BARS OTHER THAN TOP BARS  
L<sub>DT</sub> TENSION DEVELOPMENT LENGTH, TOP BARS (SEE NOTE 4)  
L<sub>SB</sub> CLASS B TENSION SPLICE, BAR SPACING  
L<sub>SBT</sub> CLASS B TENSION SPLICE, TOP BARS (SEE NOTE 4)  
L<sub>B</sub> COMPRESSION DEVELOPMENT LENGTH, BOTTOM BAR OR DOWEL
  - TOP BARS ARE HORIZONTAL BARS WITH MORE THAN 12 INCHES OF CONCRETE CAST BELOW THE BARS.
  - FOR EPOXY COATED BARS, INCREASE ALL LENGTHS 50 PERCENT.
  - USE OF THIS CHART IS RESTRICTED TO BARS WITH CONCRETE COVER OF AT LEAST ONE BAR DIAMETER AND CLEAR SPACE BETWEEN BARS OF AT LEAST TWO BAR DIMENSIONS. FOR OTHER SITUATIONS, SPLICE LENGTHS SHALL BE INCREASED BY 50%, EXCEPT FOR L<sub>B</sub>.

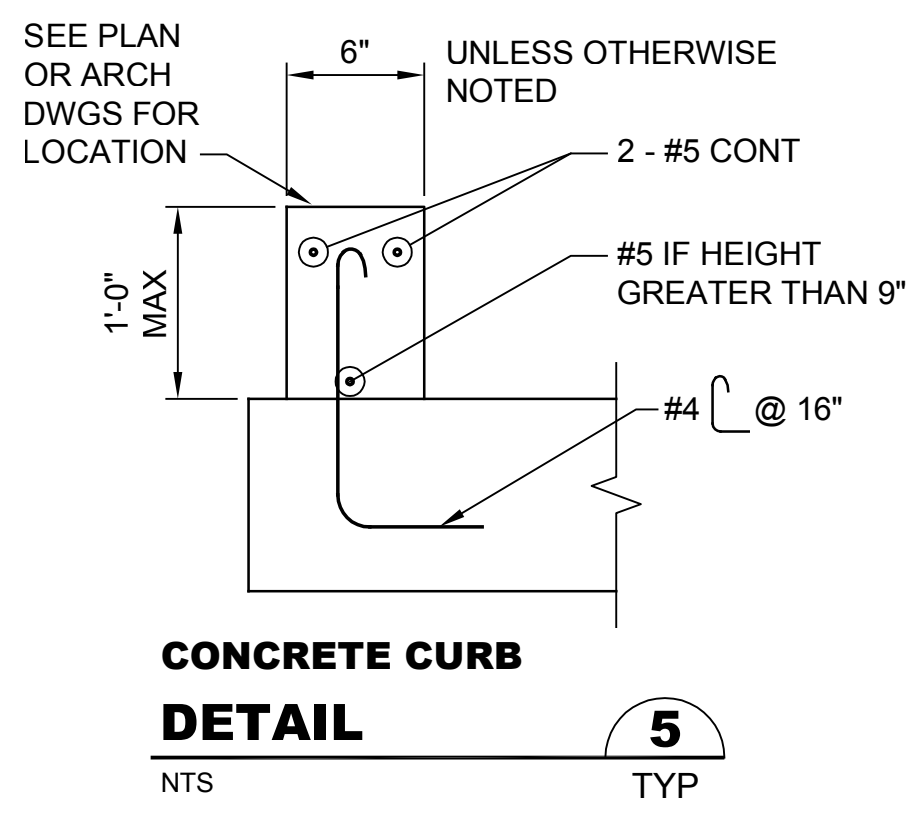
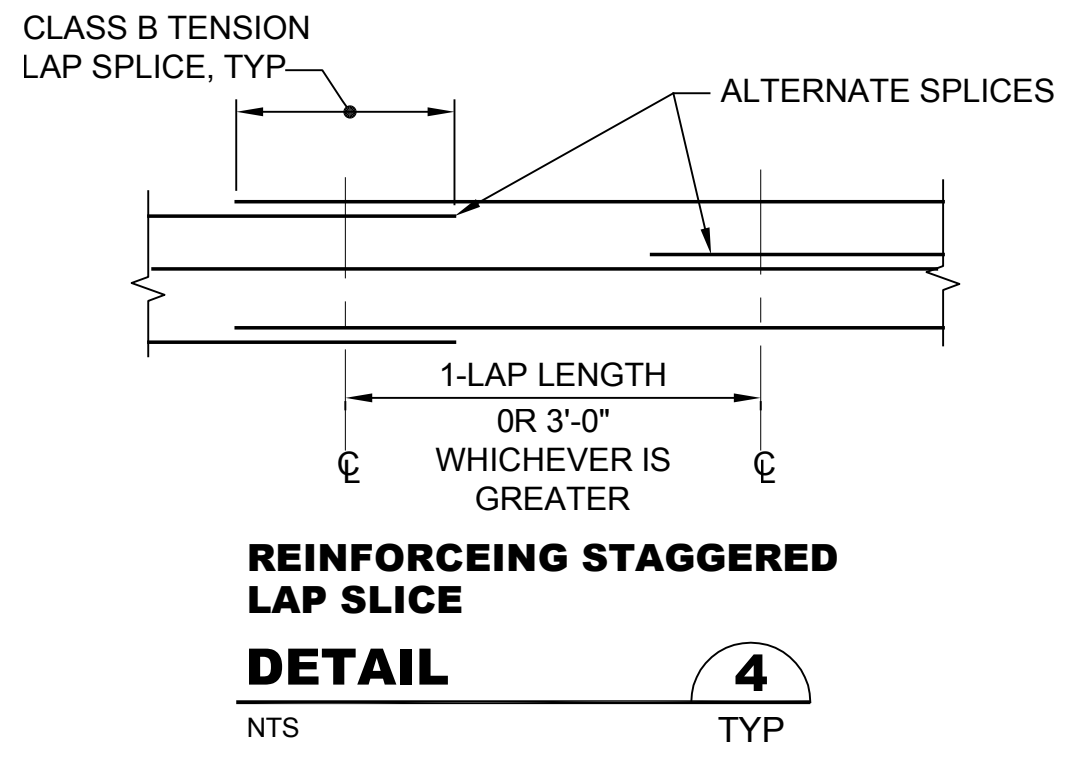
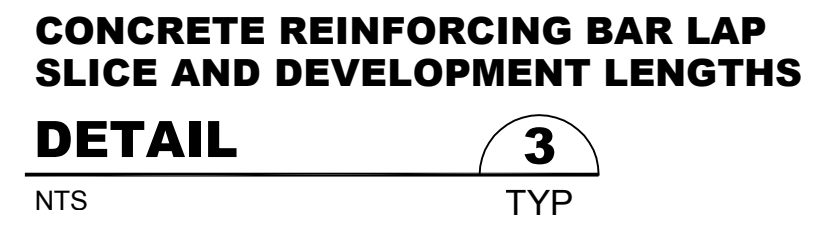

Path: S:\Cadd\Kitsap County\21-10530 Silverdale Convey-P&S-4 UprtgDesign.dwg File name: P21-10530\_S-10C Plot date: Jan 06, 2023-11:04:23am CAD User: Jilira  
Xref File name: 1\X21-10530-PSA\_TB | Fisher | Dahn | Palmatier |

**bhc CONSULTANTS**  
BHC Consultants, LLC  
1601 Fifth Avenue, Suite 500  
Seattle, Washington 98101  
206.505.3400  
206.505.3406 (fax)  
www.bhcconsultants.com

Designed: K. Dahl, P.E., S.E.  
Drawn: A. Bradley  
Checked: T. Fisher, P.E.

Scale:  
As Shown  
One Inch at Full Scale  
If Not One Inch Scale Accordingly

**Kitsap County Public Works**  
614 Division Street, MS 26  
Port Orchard, WA 98366

**SILVERDALE CONVEYANCE SYSTEM AND PUMP STATION 4 UPGRADES SCHEDULE C**  
**TYPICAL CONCRETE DETAILS**  
**1 OF 6**

**Call 48 Hours Before You Dig**  
1-800-424-5555  
UNDERGROUND SERVICE

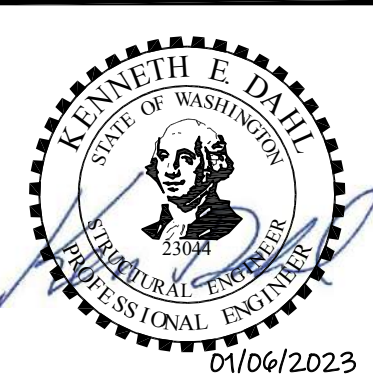

Drawing: **S-10C**  
Sheet: **68** of **117**  
File: P21-10530\_S-10C  
Date: January 2023

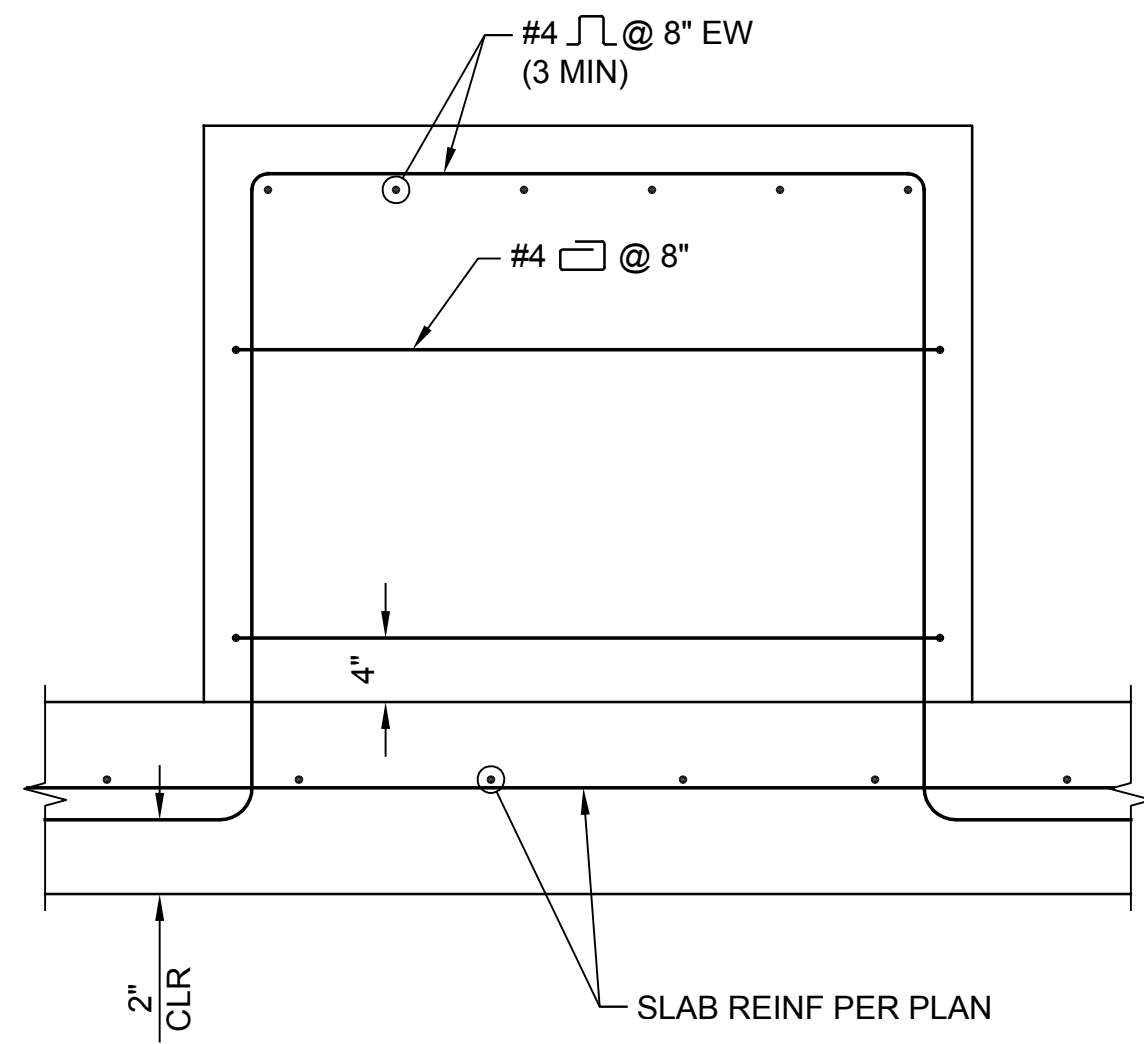

**NOTES:**

- SEE 3/- FOR ADDITIONAL INFORMATION.
- FOR EQUIPMENT PADS THAT ARE 10 INCHES OR LESS IN HEIGHT, SEE 3/-.

**TYPICAL EQUIPMENT PAD EXCEEDING 10" HEIGHT**

**DETAIL 1**  
NTS TYP

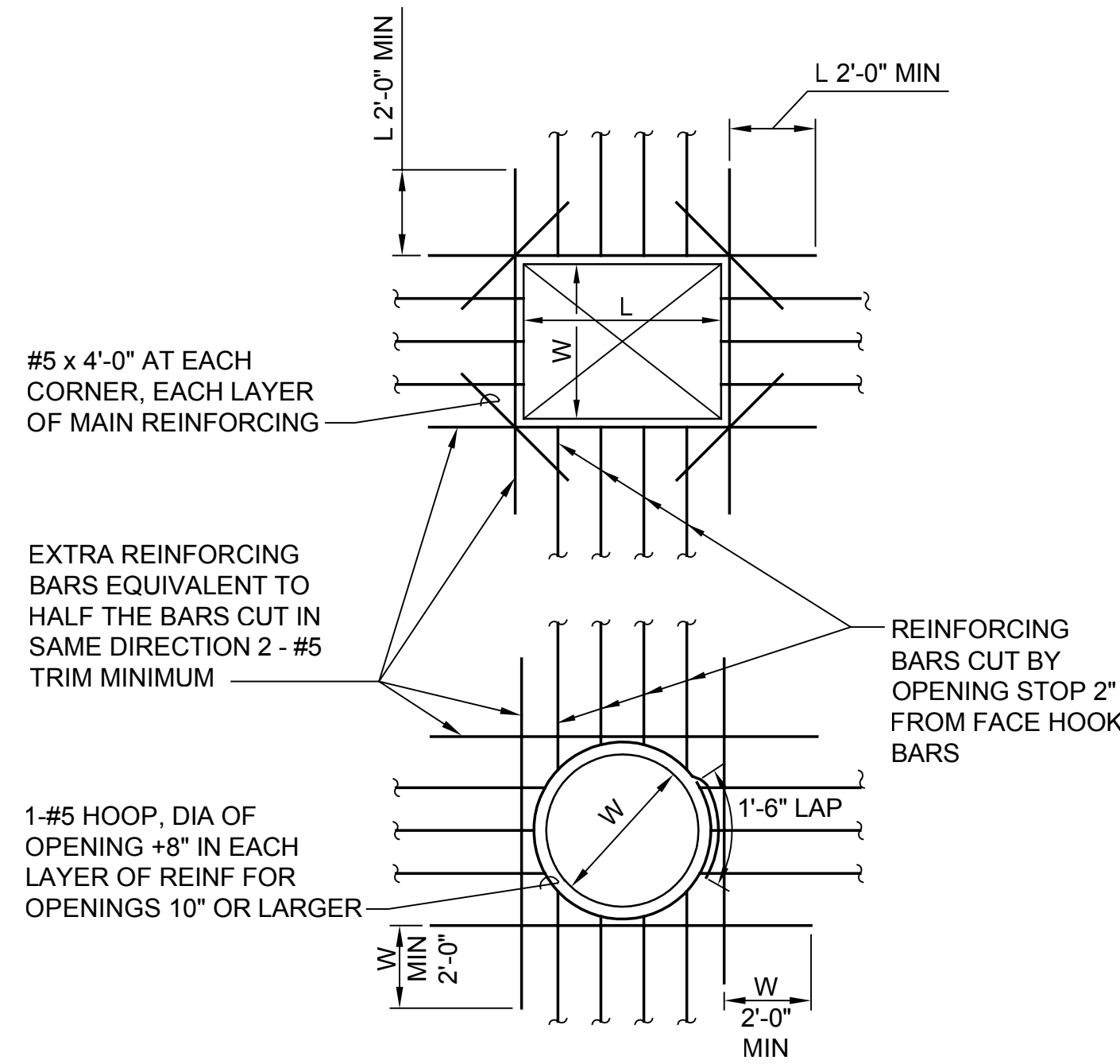

**NOTES:**

- REINFORCEMENT IN OTHER DIRECTION SHALL BE TREATED IN A SIMILAR MANNER.
- "W" AND "L" = DIMENSION OF OPENING. FOR CIRCULAR OPENINGS "W" = DIAMETER.
- OMIT ADDED REINFORCING WHEN SPECIAL REINFORCING INDICATED ON PLANS OR DETAILS EXCEED REINFORCING SHOWN HERE.
- SUPPLEMENTARY BARS MAY BE OMITTED ONLY WHERE OPENING IS FRAMED BY BEAMS.
- OPENING DETAILS SHOWN ARE TYPICAL UNLESS NOTED OTHERWISE.
- SEE MECHANICAL AND ARCHITECTURAL DRAWINGS FOR SLAB AND WALL OPENINGS NOT SHOWN ON STRUCTURAL DRAWINGS.

**REINFORCING AT WALL AND SLAB OPENING**

**DETAIL 2**  
NTS TYP

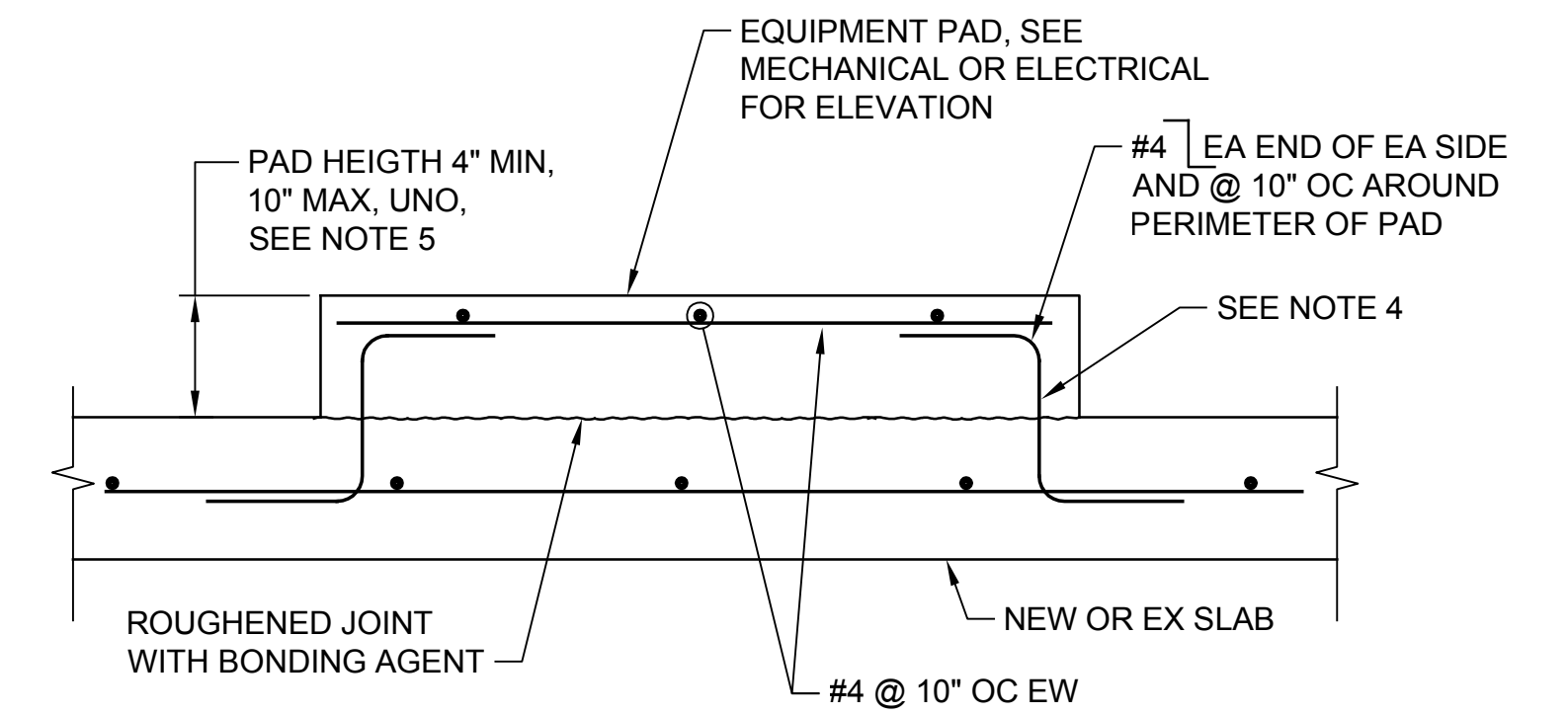

**NOTES:**

- PROVIDE EQUIPMENT PADS FOR ALL EQUIPMENT UNLESS NOTED OTHERWISE
- PROVIDE EQUIPMENT PAD DIMENSIONS, HEIGHT, AND LOCATIONS AS REQUIRED BY THE EQUIPMENT MANUFACTURER AND APPROVED BY THE ENGINEER. VERIFY EQUIPMENT PAD DIMENSIONS, HEIGHT AND LOCATION WITH THE EQUIPMENT MANUFACTURER'S REVIEWED SHOP DRAWINGS BEFORE THE PAD IS INSTALLED.
- PROVIDE ANCHOR BOLT SIZE, TYPE, QUANTITY, LOCATION, AND THREAD PROJECTION AS REQUIRED BY THE EQUIPMENT MANUFACTURER AND APPROVED BY THE ENGINEER. PROVIDE MINIMUM 1/2" DIAMETER ANCHOR BOLTS.
- AT EXISTING SLABS, DRILL AND EPOXY 3" INTO EXISTING SLAB. WHERE SLAB IS 2" TOPPING OVER HOLLOW CORE, USE 2" EMBEDMENT.
- IF PAD IS GREATER THAN 10", SEE DETAIL 1/-.

**TYPICAL EQUIPMENT PAD FOR HEIGHT 10 INCHES OR LESS**

**DETAIL 3**  
NTS TYP

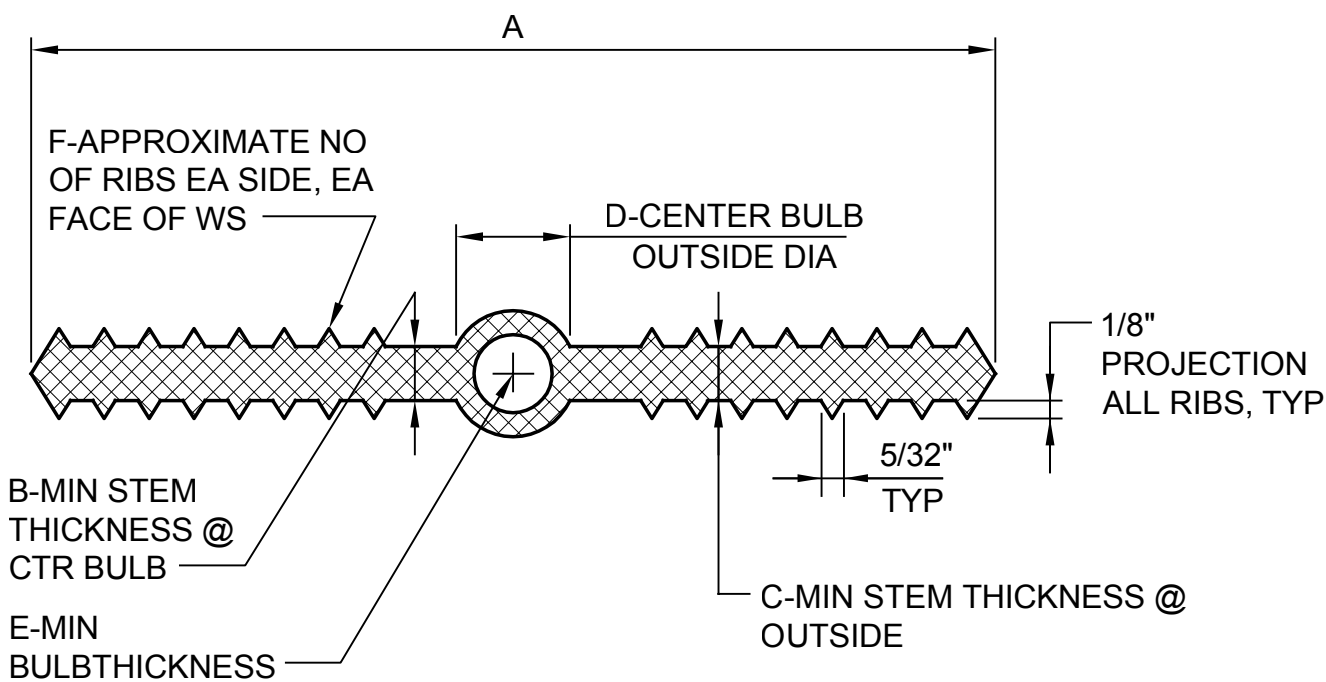

**NOTES:**

- PREFABRICATE ALL INTERSECTIONS. FIELD BUTT-WELD STRAIGHT JOINTS.
- MITER ALL FLAT JOINTS 45° AT INTERSECTIONS.
- ALL SPLICES SHALL CONFORM TO MANUFACTURER'S RECOMMENDATIONS AND THE SPECIFICATIONS.
- PROVIDE 6-INCH WATERSTOPS IN ALL SPECIFIED OR CONTRACTOR PROPOSED CONSTRUCTION JOINTS AT ALL FOUNDATION AND DIGESTER TANK WALLS.
- FURNISH DIMENSION REQUIREMENTS TO SUPPLIERS PRIOR TO PLACING ORDERS.

SIZE	A	B	C	D	E	F
6" x 3/8"	6"	3/8"	3/8"	7/8"	1/4"	6

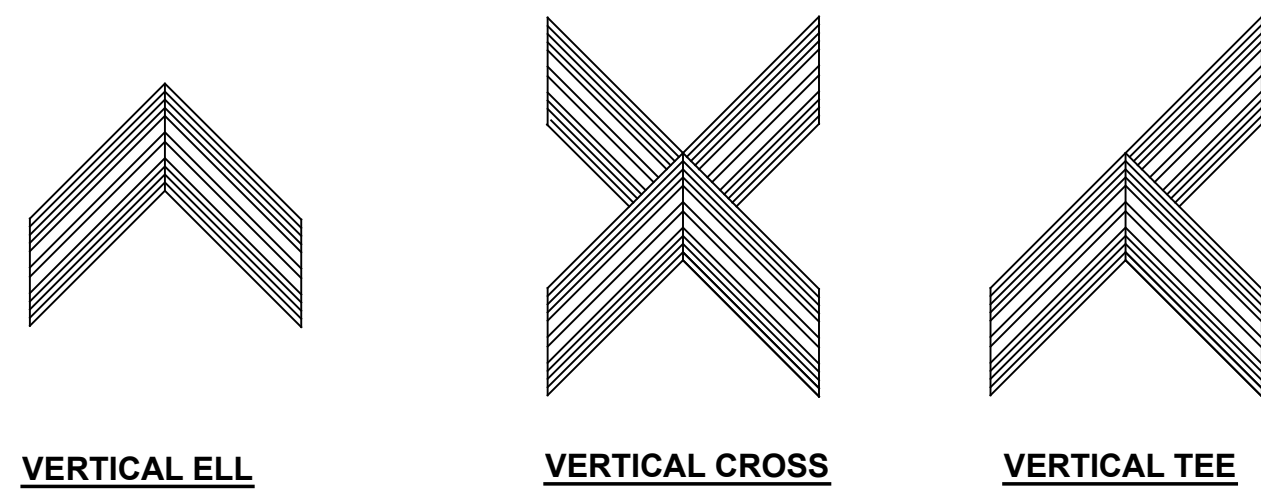

**WATERSTOP INTERSECTION SPLICES**

**TYPICAL WATERSTOP DETAIL 4**

NTS TYP

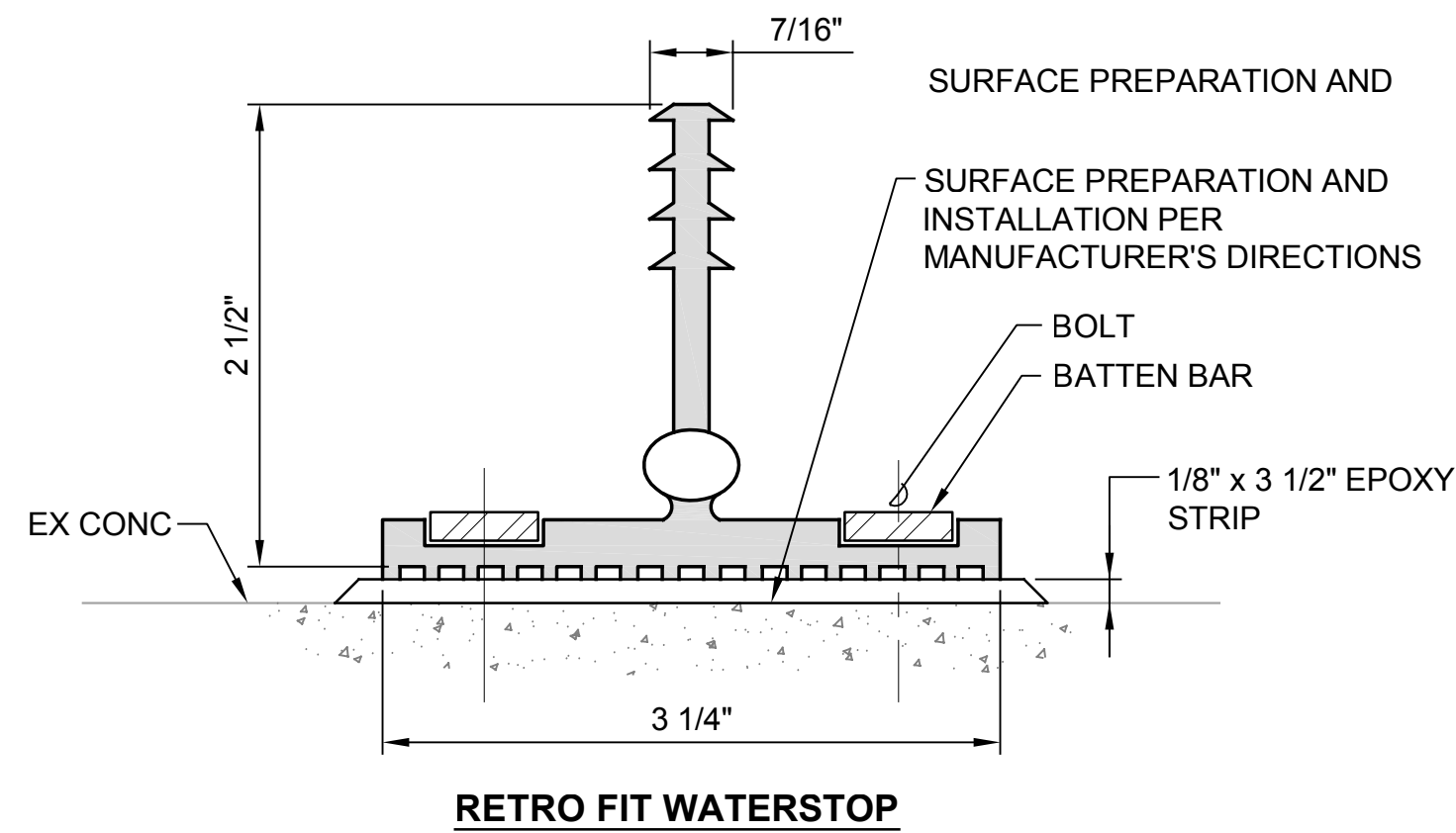

**RETRO FIT WATERSTOP**

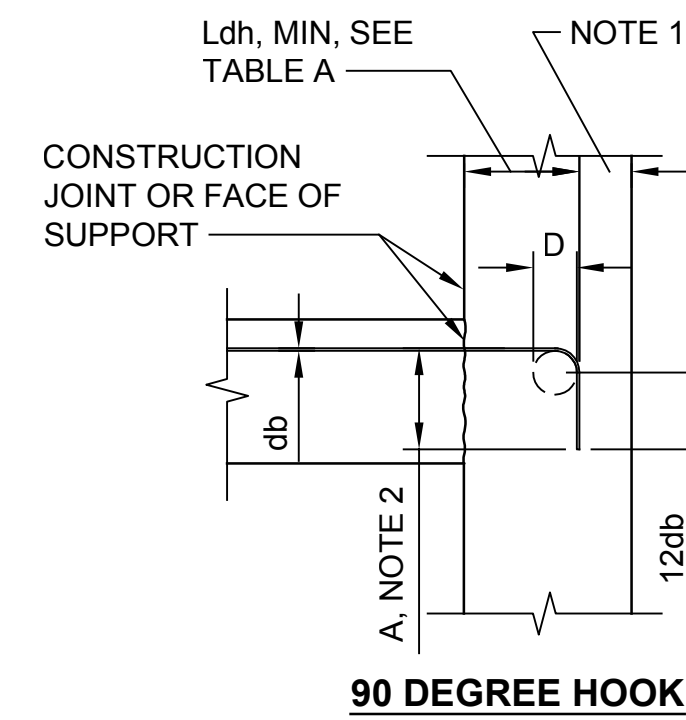

**90 DEGREE HOOK**

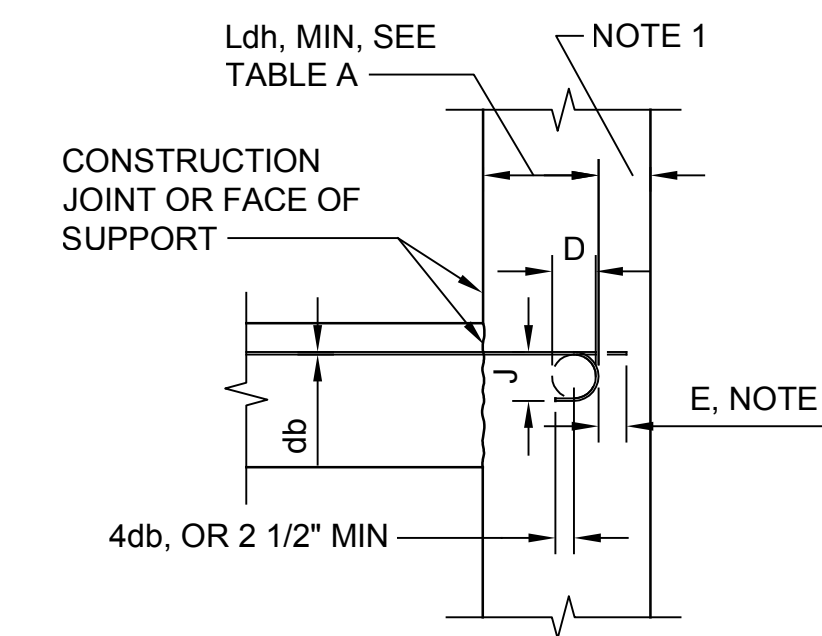

**180 DEGREE HOOK**

HOOK END				
ALL GRADES (D) FINISHED BEND DIAMETER				
BAR SIZE	D	180° HOOKS		90° HOOKS
		E	J	A
#3	2 1/4"	5"	3"	6"
#4	3"	6"	4"	8"
#5	3 3/4"	7"	5"	10"
#6	4 1/2"	8"	6"	12"
#7	5 1/4"	10"	7"	14"
#8	6"	11"	8"	16"
#9	9 1/2"	15"	11 3/4"	19"
#10	10 3/4"	17"	13 1/4"	22"
#11	12"	19"	14 3/4"	24"
#14	18 1/4"	27"	21 3/4"	31"
#18	24"	36"	28 1/2"	41"

**NOTES:**

- ABOVE VALUES VALID FOR ALL CASE IF " SIDE COVER GREATER THAN 2 1/2" END COVER GREATER THAN 2"
- BAR DIMENSION REQUIRED TO MANUFACTURE HOOK.
- FOR EPOXY COATED HOOKS, INCREASE THE ABOVE EMBEDMENT LENGTHS BY 20%.

**STANDARD HOOK & EMBEDMENT**

**DETAIL 5**  
NTS TYP

TABLE A							
MINIMUM TENSION EMBEDMENT LENGTHS, (Ldh) FOR STANDARD END HOOKS ON GRADE 60 BARS							
BAR SIZE	NORMAL WEIGHT CONCRETE, f'c (PSI)						
	3,000	4,000	5,000	6,000	7,000	8,000	
#3	6"	6"	6"	6"	6"	6"	
#4	8"	7"	7"	7"	7"	7"	
#5	10"	9"	8"	7"	7"	7"	
#6	12"	10"	9"	8"	8"	8"	
#7	14"	12"	11"	10"	9"	9"	
#8	16"	14"	12"	11"	10"	10"	
#9	18"	15"	14"	13"	12"	11"	
#10	20"	17"	15"	14"	14"	14"	
#11	22"	19"	17"	16"	15"	15"	
#14	37"	32"	29"	27"	25"	31"	
#18	50"	43"	39"	35"	33"	35"	

**Call 48 Hours Before You Dig**  
1-800-424-5555  
UNDERGROUND SERVICE

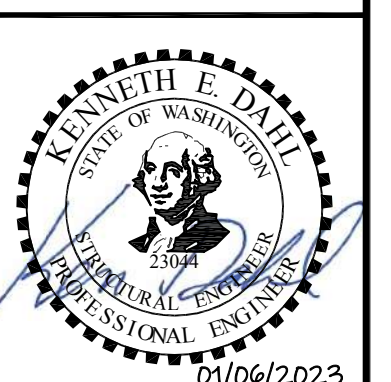

Path: S:\Cadd\Kitsap County\21-10530 Silverdale Conveyance-PS-4 UprgrDesign.d File: P21-10530\_S-11C\_Plot.dwg Date: Jan 06, 2023 11:24:41am CAD User: J.Lira Xref File: X21-10530-PS4\_TB | Fisher | Dahl | Palmatier

No.	Revision	Date	By	App'd
	ISSUED FOR BID	01-2023	TF	RAD

**bhc CONSULTANTS**  
BHC Consultants, LLC  
1601 Fifth Avenue, Suite 500  
Seattle, Washington 98101  
206.505.3400  
206.505.3406 (fax)  
www.bhcconsultants.com

Designed: K. Dahl, P.E., S.E.  
Drawn: A. Bradley  
Checked: T. Fisher, P.E.

Scale: NTS  
One Inch at Full Scale  
If Not One Inch Scale Accordingly

**Kitsap County Public Works**  
614 Division Street, MS 26  
Port Orchard, WA 98366

**SILVERDALE CONVEYANCE SYSTEM AND PUMP STATION 4 UPGRADES SCHEDULE C**  
**TYPICAL CONCRETE DETAILS**  
**2 OF 6**

Drawing: **S-11C**  
Sheet: **69** of **117**  
File: P21-10530\_S-11C  
Date: January 2023

Path: S:\Cadd\Kitsap County\21-10530 Silverdale Conveyance-PS-4 Uprgr\Design\Drawings\21-10530-PS-4\_TB\_1\Fisher\Detail\1 Palmattler

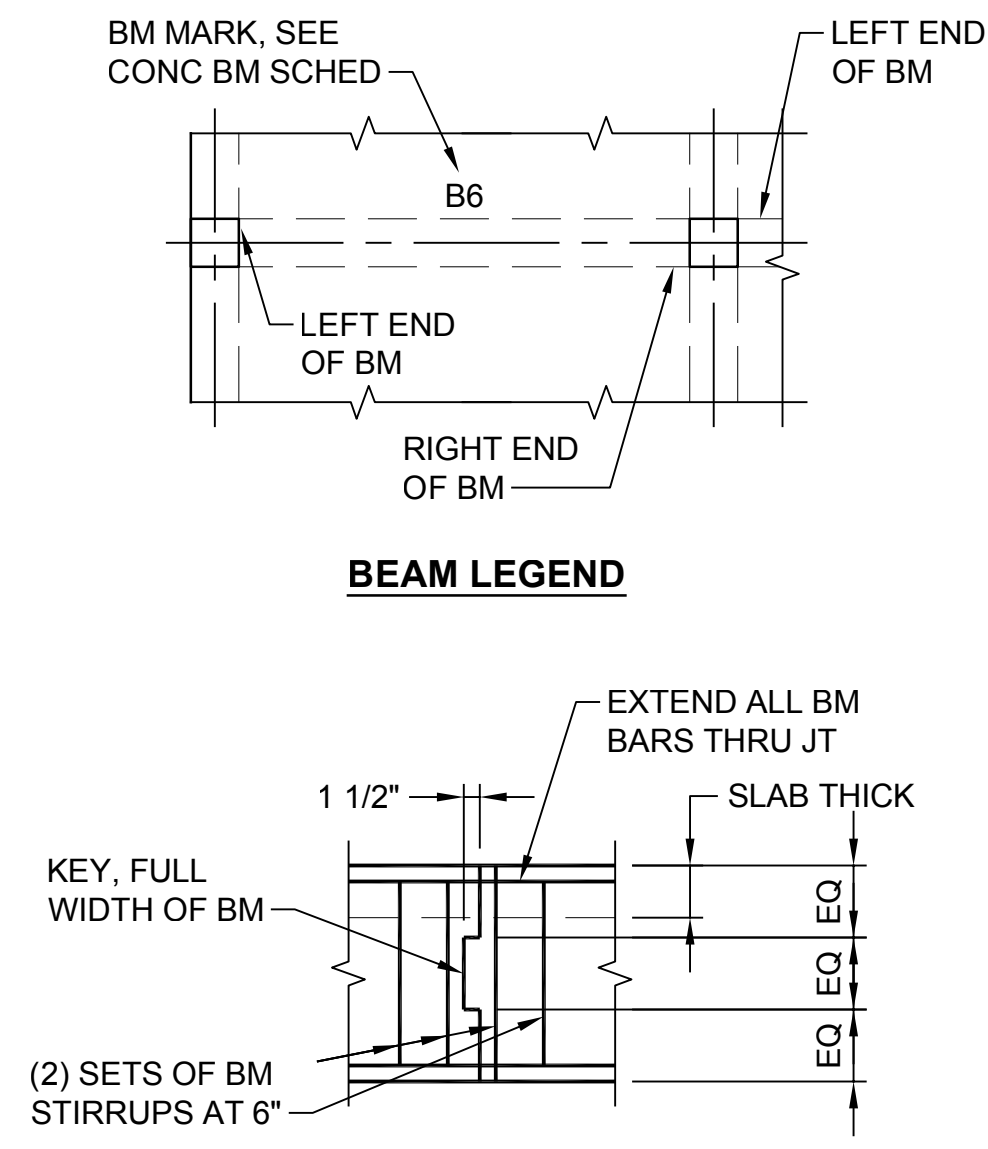
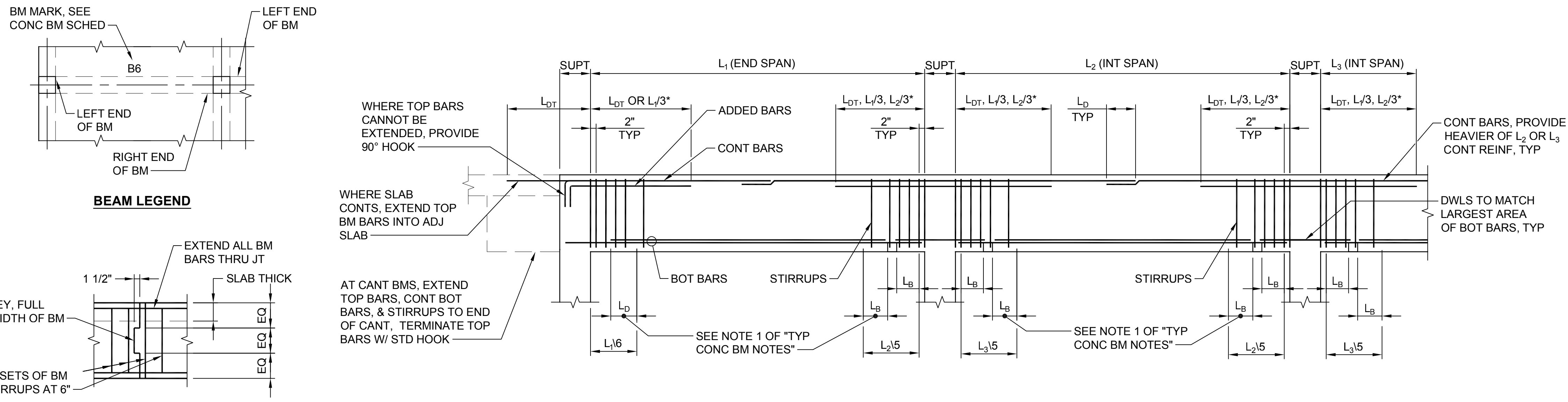

**NOTES:**  
 1. SEE NOTE 6 OF "TYPICAL CONCRETE BEAM NOTES".

**BEAM REINFORCING ELEVATION**  
 \*WHICHEVER IS GREATER

**TYPICAL CONCRETE BEAM DETAIL 1**  
 NTS TYP

- TYPICAL CONCRETE BEAM NOTES:**
- AT CONTRACTOR'S OPTION, WHERE REQUIRED TO RELIEVE BAR CONGESTION, NOT MORE THAN 50 PERCENT OF THE AREA OF THE STRAIGHT BOTTOM BARS MAY BE TERMINATED AS SHOWN UNLESS NOTED OTHERWISE.
  - PLANS, SECTIONS AND DETAILS DO NOT INDICATE REQUIREMENTS FOR ARRANGING BARS. THE CONTRACTOR SHALL DETAIL AND PLACE REINFORCING STEEL IN A SINGLE LAYER WHENEVER POSSIBLE. A SECOND LAYER MAYBE USED ONLY WHERE REQUIRED TO PROVIDE PROPER CLEARANCE BETWEEN BARS IN A LAYER AND WHERE REQUIRED IN ORDER TO PROPERLY CLEAR COLUMN VERTICALS AND SIMILAR REINFORCING.
  - REFER TO "REINFORCING BAR DEVELOPMENT AND SPLICE LENGTH TABLE" FOR  $L_{DT}$ ,  $L_B$ , AND  $L_D$ .
  - EITHER 90 OR 180 DEGREE STANDARD HOOK BARS MAY BE USED FOR LONGITUDINAL BARS.
  - WHERE TOP BARS ARE INDICATED AS CONTINUOUS AND RUN OVER 60 FEET IN LENGTH, BARS MAY BE LAPPED  $L_D$  IN THE MIDDLE THIRD OF THE BEAM SPAN UNLESS NOTED OTHERWISE. CONTINUOUS TOP BARS SHALL NOT BE LAPPED IN THE SPAN ADJACENT TO A CANTILEVER, UNLESS NOTED OTHERWISE. WHERE BOTTOM BARS ARE SHOWN AS CONTINUOUS AND RUN IN EXCESS OF 60 FEET, A LAP SPLICE MAY BE USED EQUAL TO  $L_{SB}$  AND SHALL BE OUTSIDE THE MIDDLE THIRD OF THE BEAM SPAN. SIDE BAR SPLICES MA BE MADE WHERE CONVENIENT.
  - LOCATE ALL CONSTRUCTION JOINTS WITHIN THE MIDDLE THIRD OF SPAN. JOINTS SHALL BE OFFSET AT A MINIMUM DISTANCE OF TWO TIMES THE WIDTH OF INTERSECTING BEAMS. SUBMIT LOCATION OF ALL CONSTRUCTION JOINTS TO ENGINEER FOR REVIEW AND ACCEPTANCE BEFORE FORMING.
  - STANDARD HOOKS FOR STIRRUPS MAY BE 135 DEGREES BEND PLUS 6 BAR DIAMETER EXTENSION, BUT NOT LESS THAN 3 INCHES.
  - ALL BARS IN SAME LAYER UNLESS NOTED OTHERWISE.
  - SEE PLANS, SECTIONS, AND DETAILS FOR BAR SIZES AND LAYOUT.

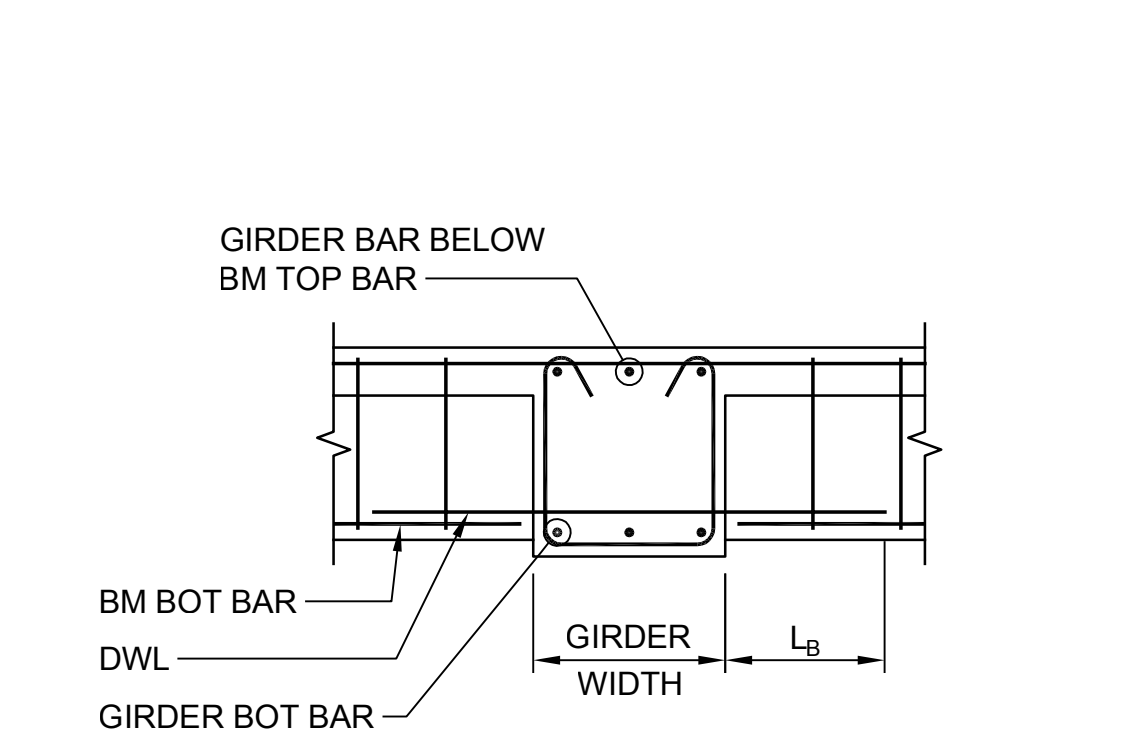
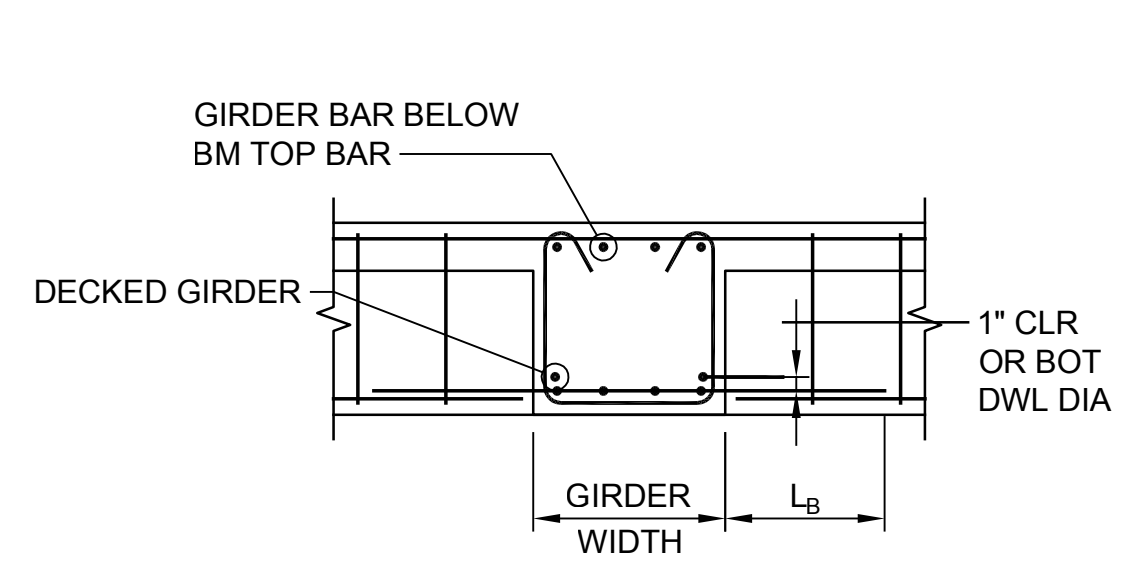

**TYPICAL CONCRETE BEAM AND GIRDER INTERSECTION DETAIL 2**  
 NTS TYP

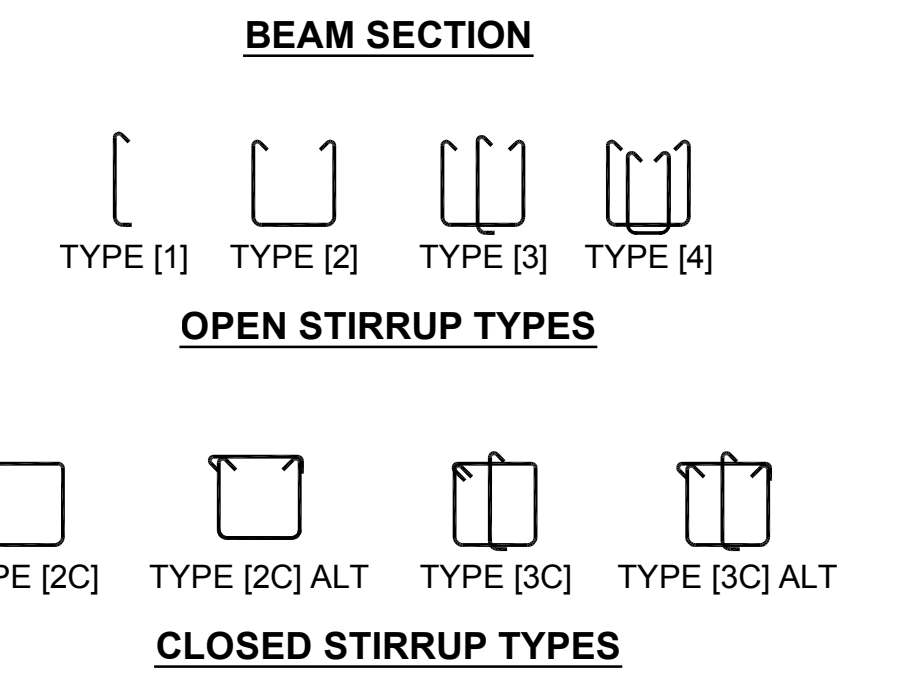
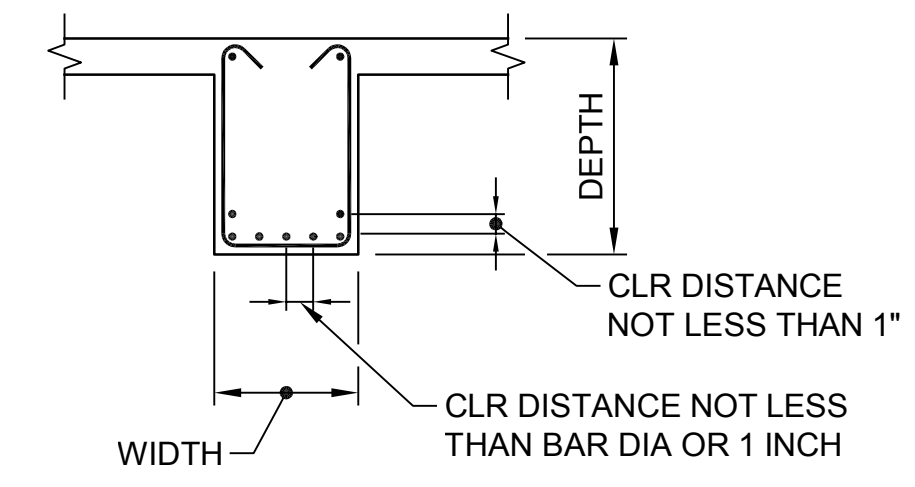

**NOTES:**  
 1. [ ] DENOTES TYPE OF STIRRUP REINFORCING CONFIGURATION. SEE CONCRETE BEAM SCHEDULE.

**TYPICAL CONCRETE BEAM SECTIONS AND STIRRUPS DETAIL 3**  
 NTS TYP

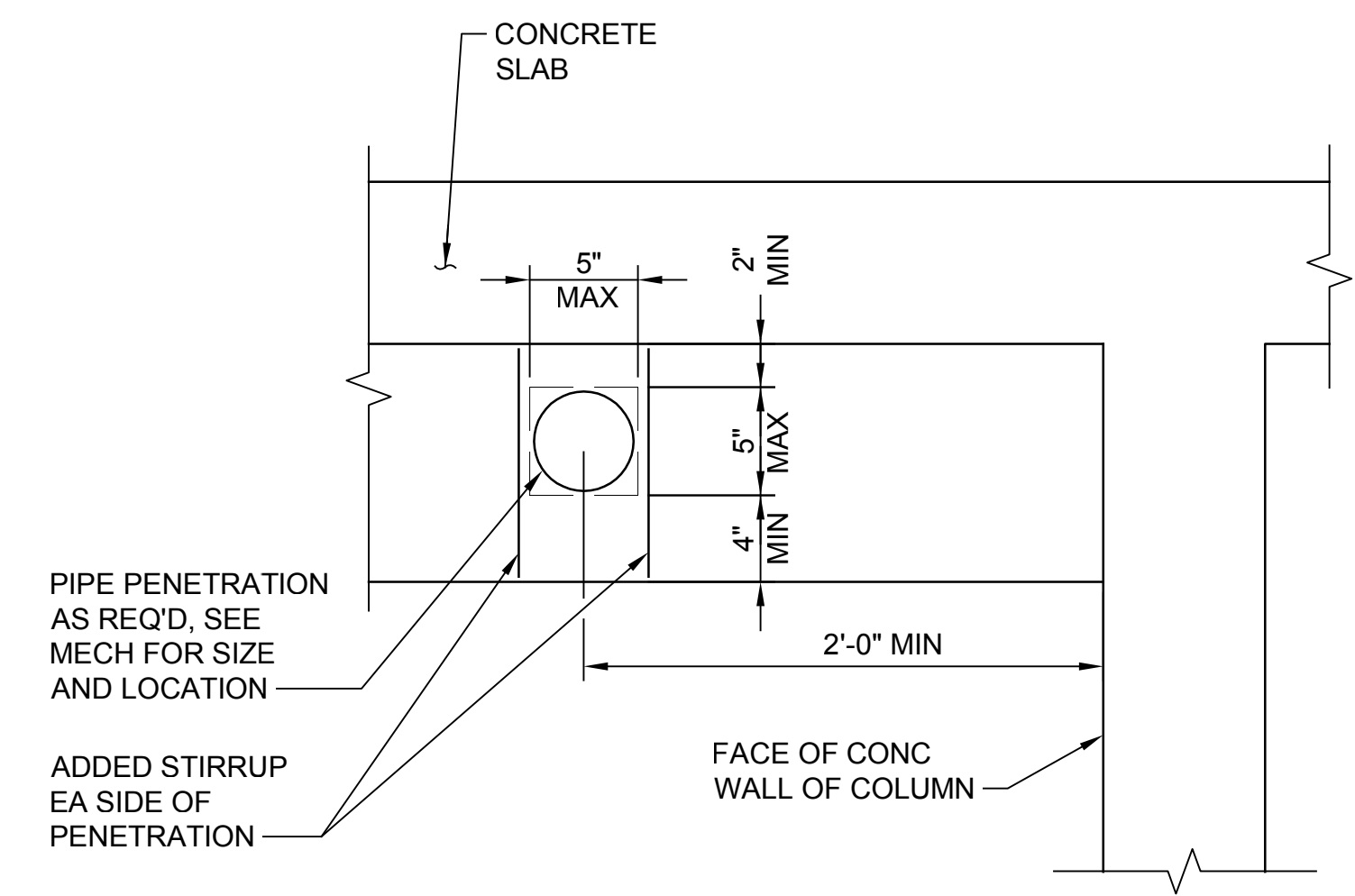

**NOTES:**

- PENETRATIONS MUST BE SPACED 3 DIAMETERS OR 3X WIDTH OF PENETRATION APART.
- PENETRATIONS MUST BE COORDINATED WITH MECHANICAL CONTRACTOR 2 WEEKS PRIOR TO SHOP DRAWING PRODUCTION COMMENCING.
- PENETRATION MAY BE ROUND OR RECTANGULAR

**TYPICAL CONCRETE BEAM HORIZONTAL PENETRATION DETAIL 4**  
 SCALE: 1 1/2" = 1'-0" TYP

**Call 48 Hours Before You Dig**  
 1-800-424-5555  
 UNDERGROUND SERVICE



Drawing: **S-12C**  
 Sheet: **70** of **117**  
 File: P21-10530-PS4\_S-12C  
 Date: January 2023

**bhc CONSULTANTS**  
 BHC Consultants, LLC  
 1601 Fifth Avenue, Suite 500  
 Seattle, Washington 98101  
 206.505.3400  
 206.505.3406 (fax)  
 www.bhcconsultants.com

Designed: K. Dahl, P.E., S.E.  
 Scale: As Shown  
 One Inch at Full Scale  
 If Not One Inch Scale Accordingly  
 Drawn: A. Bradley  
 Checked: T. Fisher, P.E.

**Kitsap County Public Works**  
 614 Division Street, MS 26  
 Port Orchard, WA 98366

**SILVERDALE CONVEYANCE SYSTEM AND PUMP STATION 4 UPGRADES SCHEDULE C**  
**TYPICAL CONCRETE DETAILS**  
**3 OF 6**

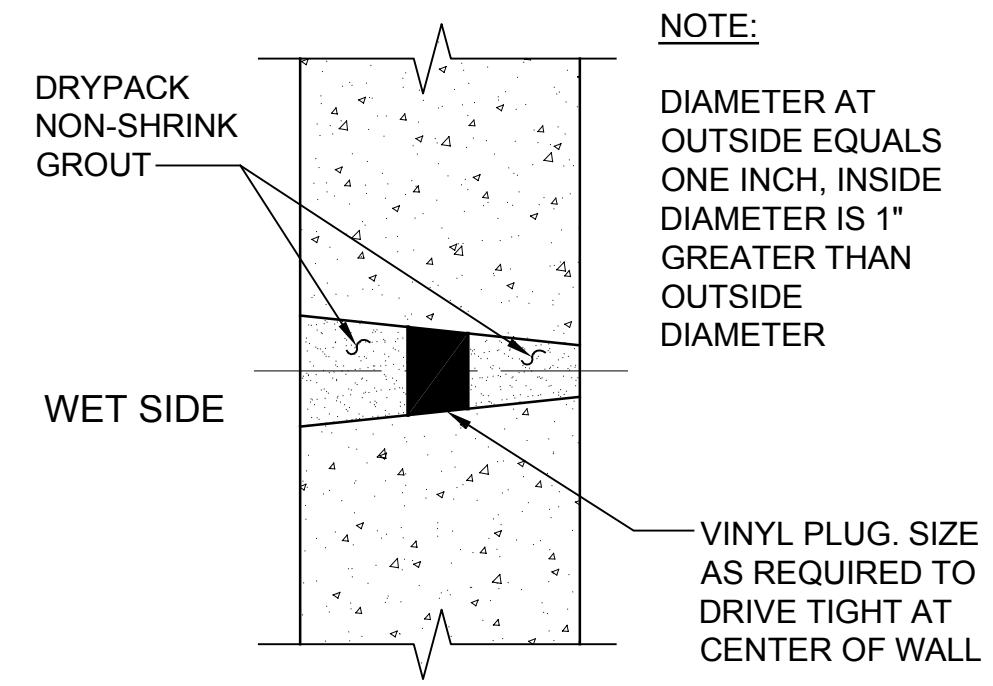

**CONSTRUCTION STEPS:**

1. SANDBLAST OR MECHANICALLY ROUGHEN TAPERED TIE-HOLE SURFACES.
2. DRIVE IN VINYL PLUG.
3. PROVIDE BONDING AGENT INSIDE AND DRYPACK WITH NON-SHRINK GROUT WHILE STILL TACKY.
4. PROVIDE BONDING AGENT OUTSIDE AND DRYPACK WITH NON-SHRINK GROUT WHILE STILL TACKY.
5. WET SIDE IS CONTENTS SIDE FOR TANKS, EXTERIOR SIDE FOR FOUNDATION WALLS.

**TYPICAL FORM TAPER TIE HOLE DETAIL**  
NTS TYP

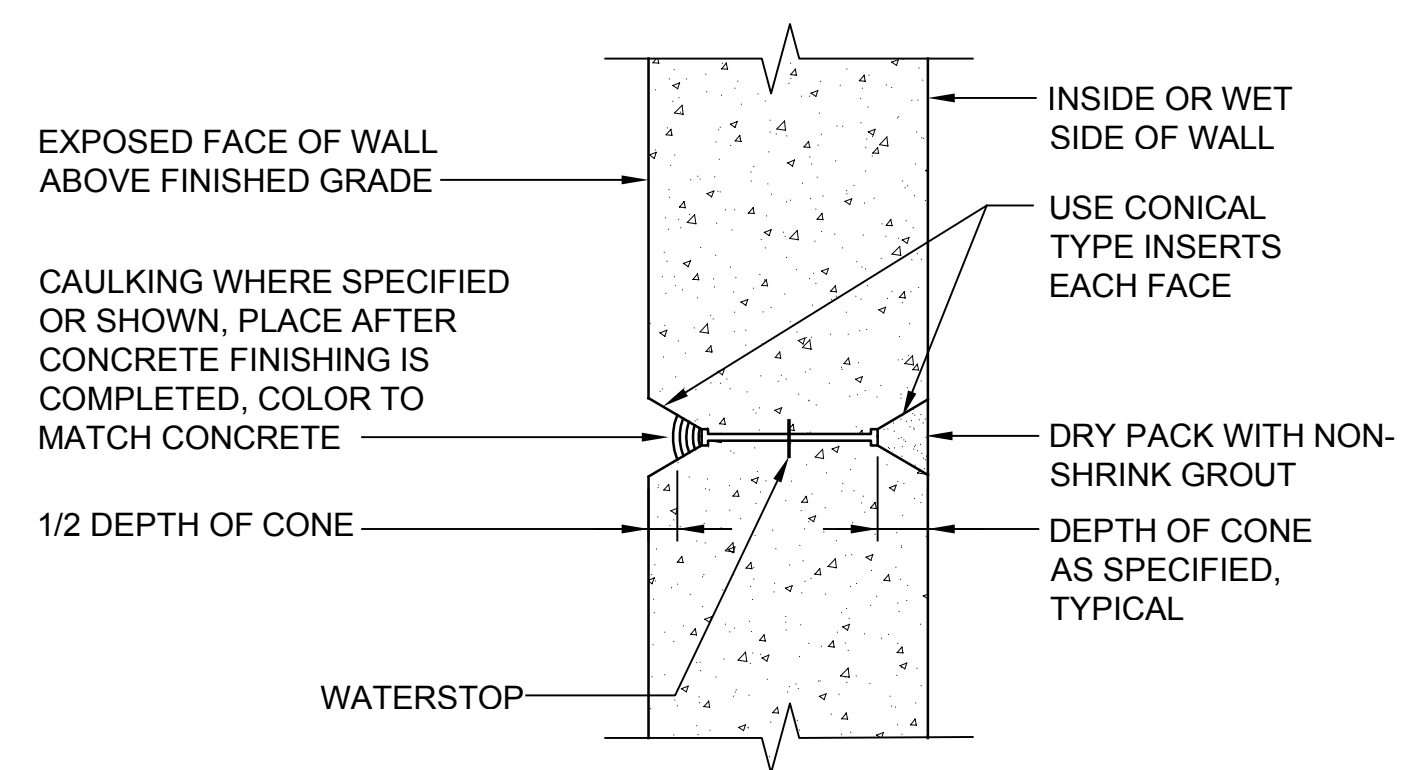

**NOTES:**

1. FOR FORM TIE HOLES ON OUTSIDE FACE OF WALL BELOW GRADE. DRY PACK WITH NON-SHRINK GROUT.
2. SPACE FORM TIES ON EXPOSED PORTIONS OF WALLS APPROXIMATELY EQUAL HORIZONTALLY AND VERTICALLY AND UNIFORMLY IN EACH DIRECTION.
3. WHERE CAULKING IS NOT SPECIFIED OR SHOWN, DRY PACK EXTERIOR TIE HOLES WITH NON-SHRINK GROUT. GROUT COLOR TO MATCH COLOR OF CONCRETE.
4. DRY PACK USING STEEL TOOLS.

**TYPICAL FORM SNAP TIE HOLE DETAIL**  
NTS TYP

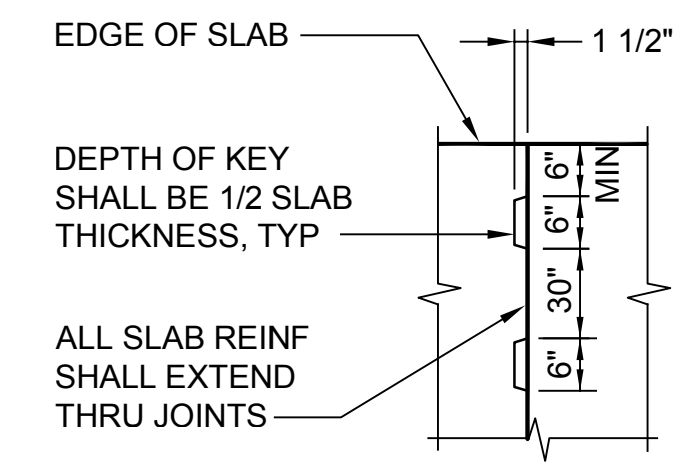

**NOTE:**

LOCATE ALL CONSTRUCTION JOINTS WITHIN THE MIDDLE THIRD OF THE SPAN. SUBMIT LOCATIONS OF ALL CONSTRUCTION JOINTS TO ENGINEER FOR REVIEW AND ACCEPTANCE BEFORE FRAMING.

**SLAB CONSTRUCTION JOINT PLAN**

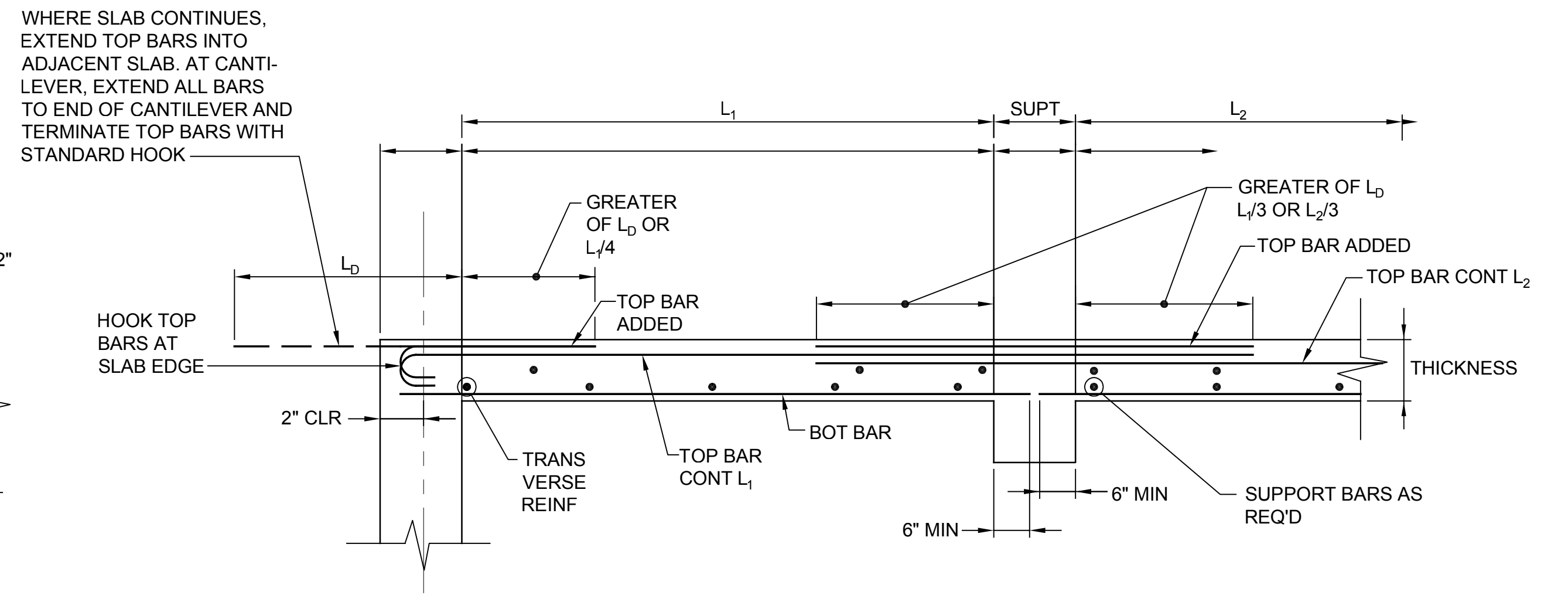

**NOTE:**

1. IF TOP BARS ARE NOT NOTED ON PLANS, PROVIDE EQUIV TO 1/2 BOT OR #4 @ 16" MIN
2. SEE PLAN FOR REINFORCEMENT REQUIREMENTS.

**TYPICAL ONE WAY SLAB DETAIL**  
NTS TYP

**MAIN REINFORCEMENT**

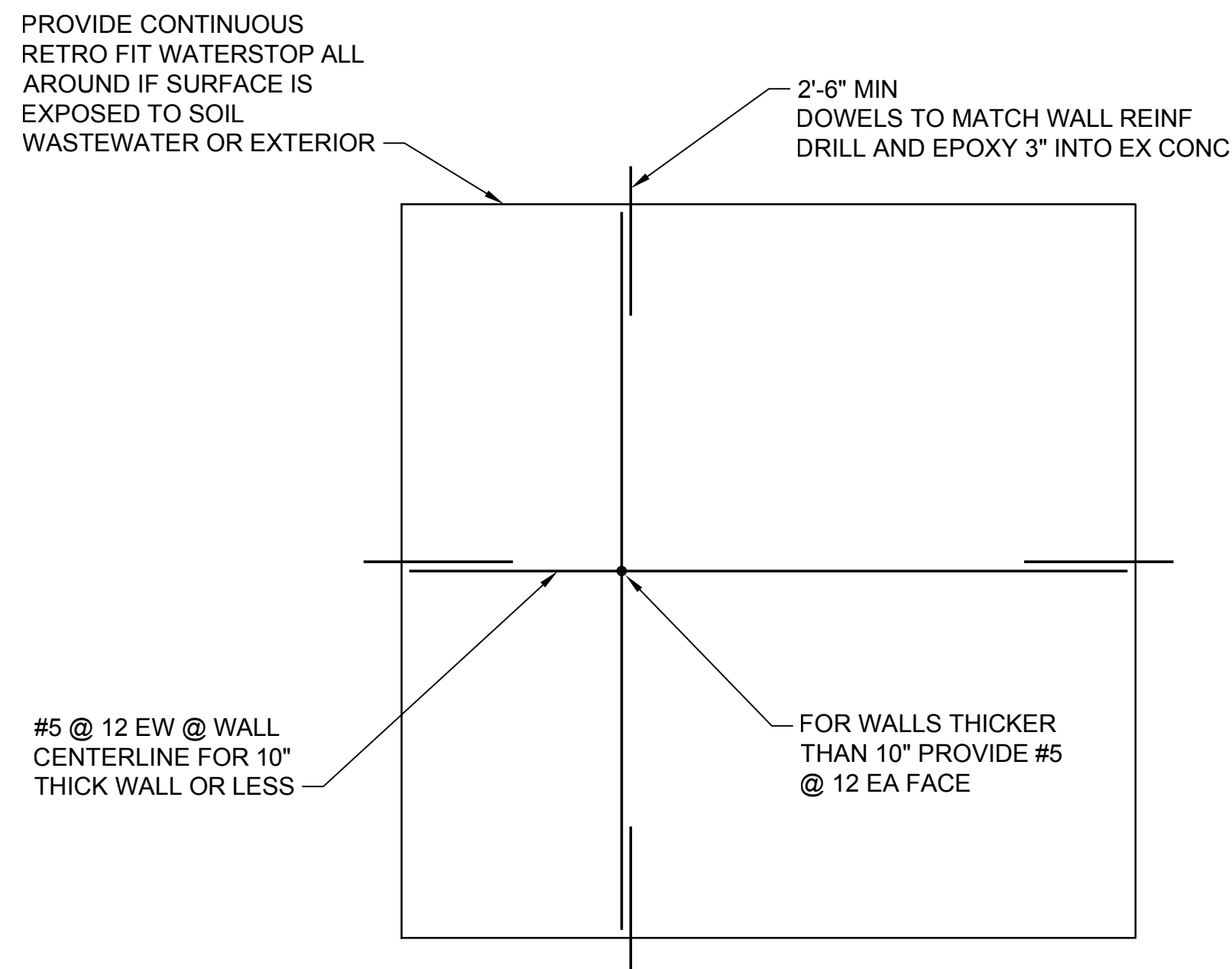

**NOTES:**

1. AT CONTRACTOR'S OPTION, DOWELS MAY EXTEND FULL LENGTH OR WIDTH FULLY OVERLAPPING OPPOSITE DOWEL IN LIEU OF ADDING FIELD REINF IN OPENING

**TYPICAL CONC WALL INFILL DETAIL**  
NTS TYP

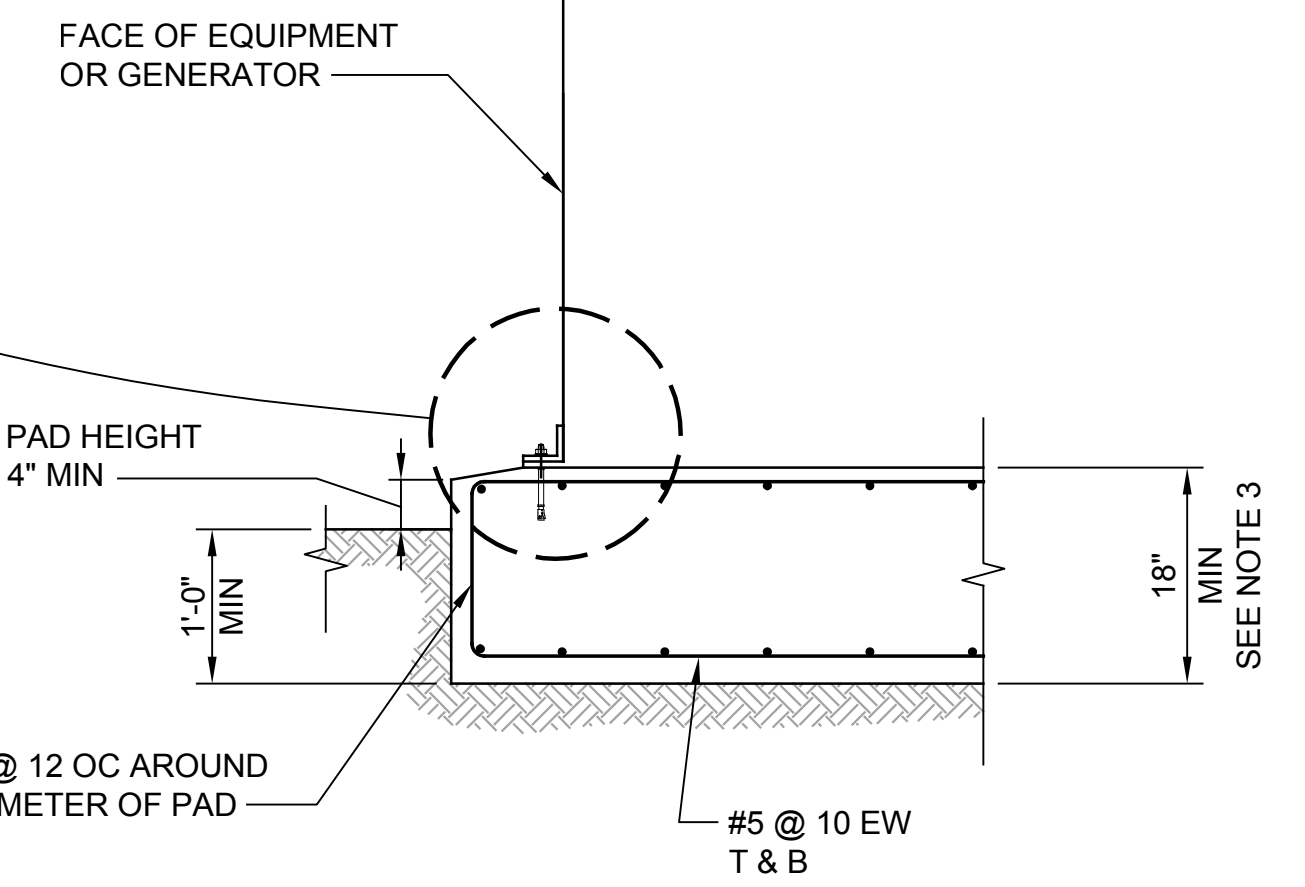
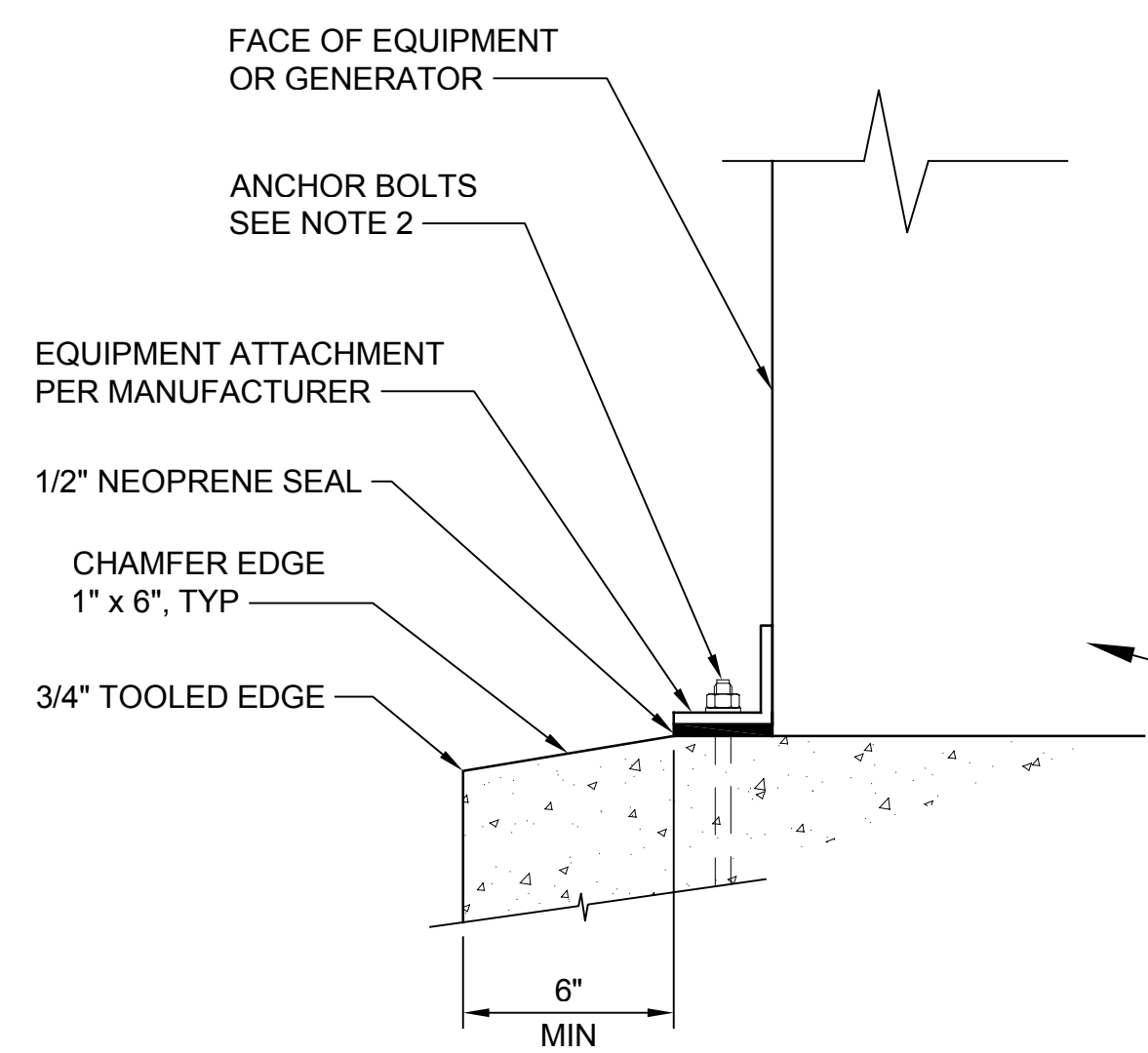

**NOTES:**

1. VERIFY EQUIPMENT/GENERATOR PAD DIMENSIONS WITH THE MANUFACTURER'S REVIEWED SHOP DRAWINGS BEFORE THE PAD IS INSTALLED.
2. PROVIDE SST ANCHOR BOLT SIZE, TYPE, QUANTITY, LOCATION, AND THREAD PROJECTION AS REQUIRED BY THE MANUFACTURER AND APPROVED BY THE ENGINEER. PROVIDE MINIMUM 1/2" DIAMETER ANCHOR BOLTS.
3. ALL THREE MINIMUM DIMENSION CRITERIA MUST BE MET DURING CONSTRUCTION.

**TYPICAL EQUIPMENT/GENERATOR PAD DETAIL**  
SCALE: 3/4" = 1'-0" TYP

**Call 48 Hours Before You Dig**  
1-800-424-5555  
UNDERGROUND SERVICE

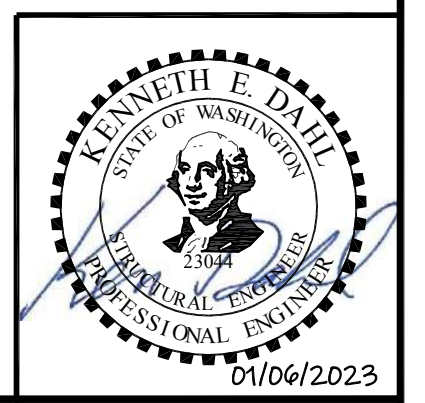

Path: S:\Cadd\Kitsap County\21-10530 Silverdale Conveyance\PS 4 Uprgt\Design\Drawings\21-10530-PS\_4\_TB\_1\Fisher\Detail\Palmtier.dwg  
Xref Filename: 21-10530-PS\_4\_TB\_1\Fisher\Detail\Palmtier.dwg  
Filename: P21-10530\_S-13C Plot date: Jan 06, 2023 11:30:47am CAD User: J. Jira

No.	Revision	Date	By	App'd
	ISSUED FOR BID	01-2023	TF	RAD

**bhc CONSULTANTS**  
BHC Consultants, LLC  
1601 Fifth Avenue, Suite 500  
Seattle, Washington 98101  
206.505.3400  
206.505.3406 (fax)  
www.bhcconsultants.com

Designed: K. Dahl, P.E., S.E.  
Drawn: A. Bradley  
Checked: T. Fisher, P.E.

Scale:  
As Shown  
One Inch at Full Scale  
If Not One Inch Scale Accordingly



**Kitsap County Public Works**  
614 Division Street, MS 26  
Port Orchard, WA 98366

**SILVERDALE CONVEYANCE SYSTEM AND PUMP STATION 4 UPGRADES SCHEDULE C**  
**TYPICAL CONCRETE DETAILS**  
**4 OF 6**

Drawing: **S-13C**  
Sheet: **71** of **117**  
File: P21-10530\_S-13C  
Date: January 2023

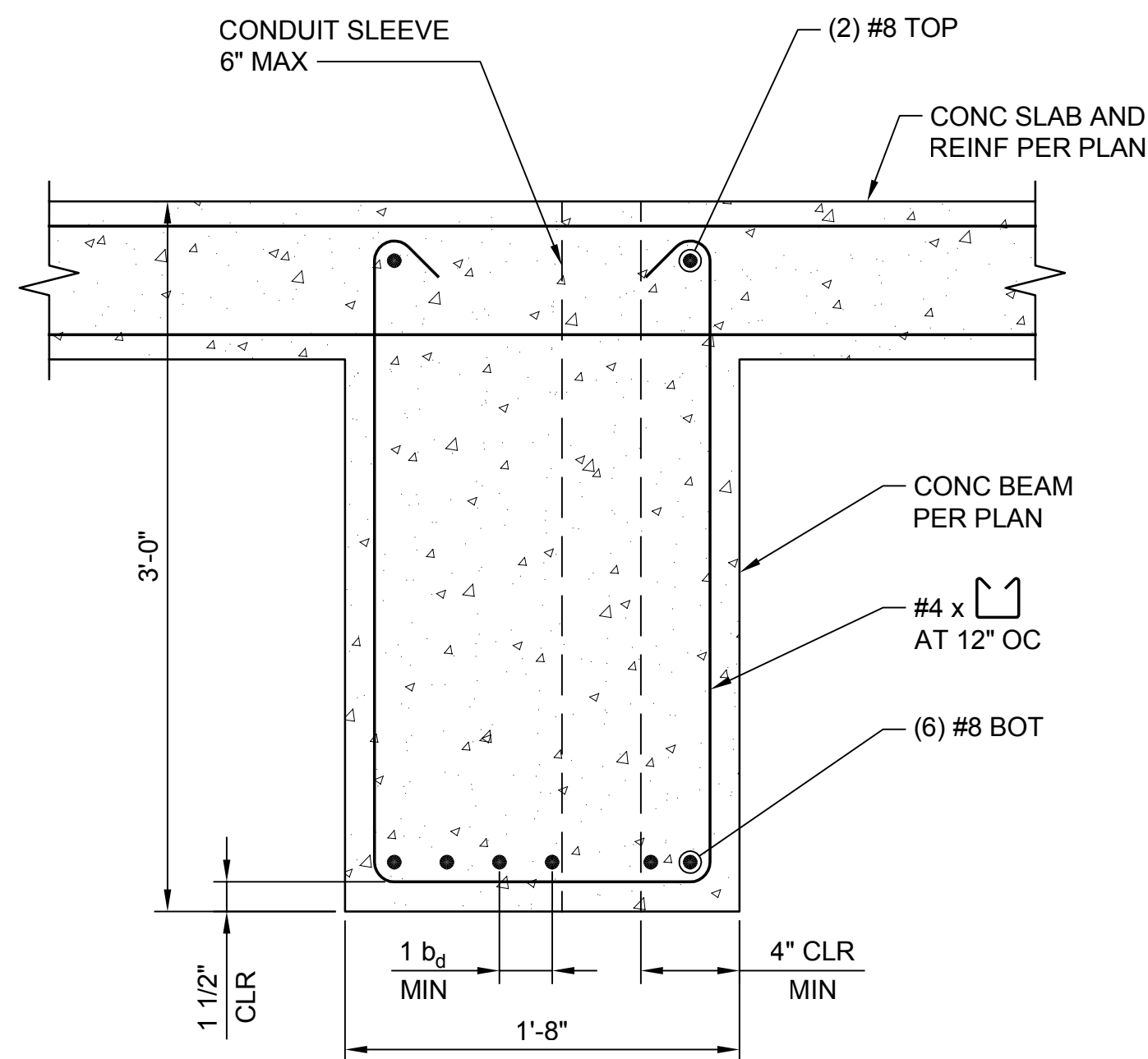

**NOTES:**

- STANDARD HOOKS FOR STIRRUPS MAY BE 135° BEND PLUS 6 BAR DIAMETER EXTENSION, BUT NOT LESS THAN 3 INCHES.

**TYPICAL CONCRETE BEAM SECTION A**

SCALE: 1 1/2" = 1'-0"

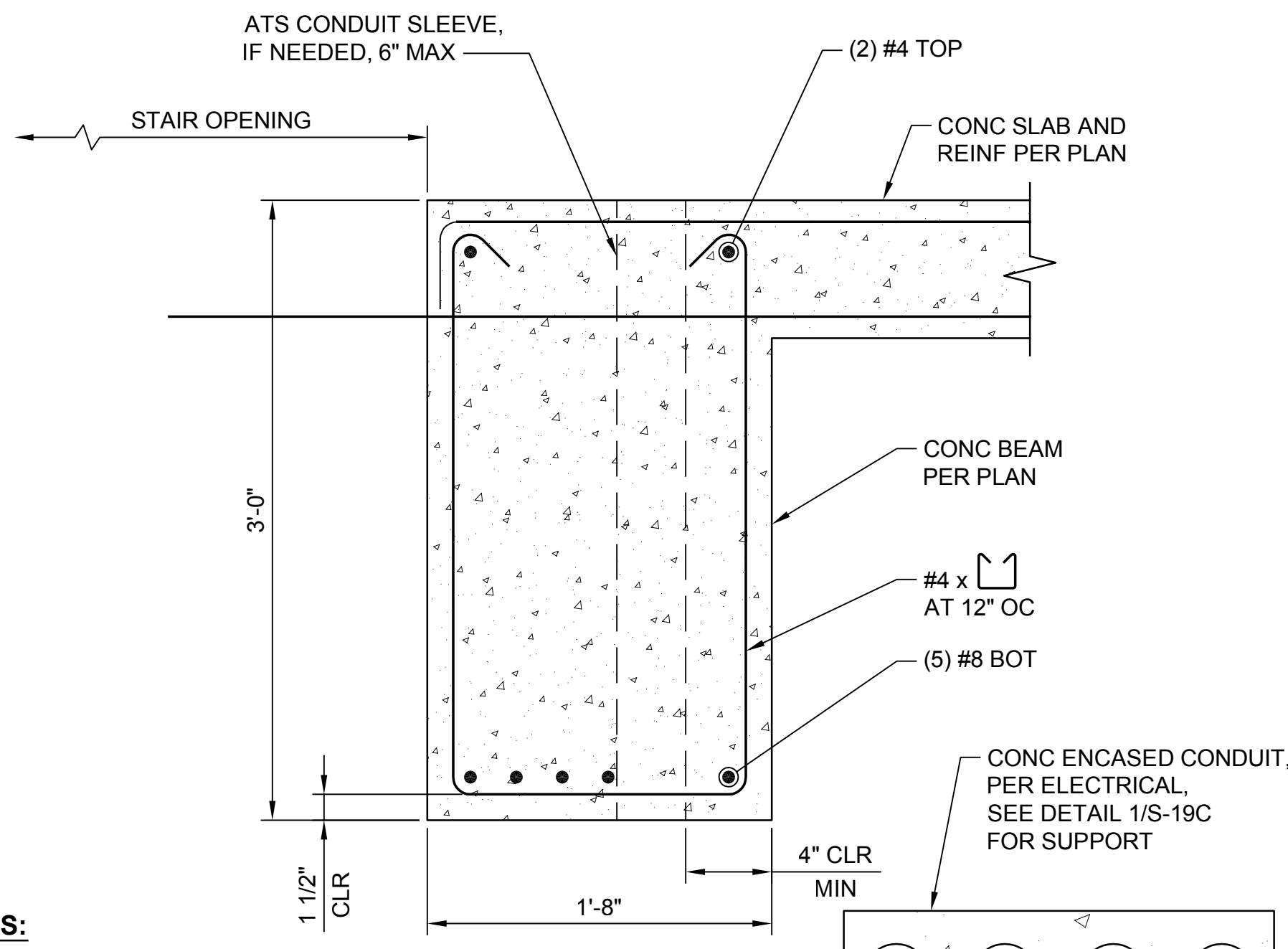

**NOTES:**

- STANDARD HOOKS FOR STIRRUPS MAY BE 135° BEND PLUS 6 BAR DIAMETER EXTENSION, BUT NOT LESS THAN 3 INCHES.

**TYPICAL CONCRETE BEAM AT STAIR OPENING SECTION B**

SCALE: 1 1/2" = 1'-0"

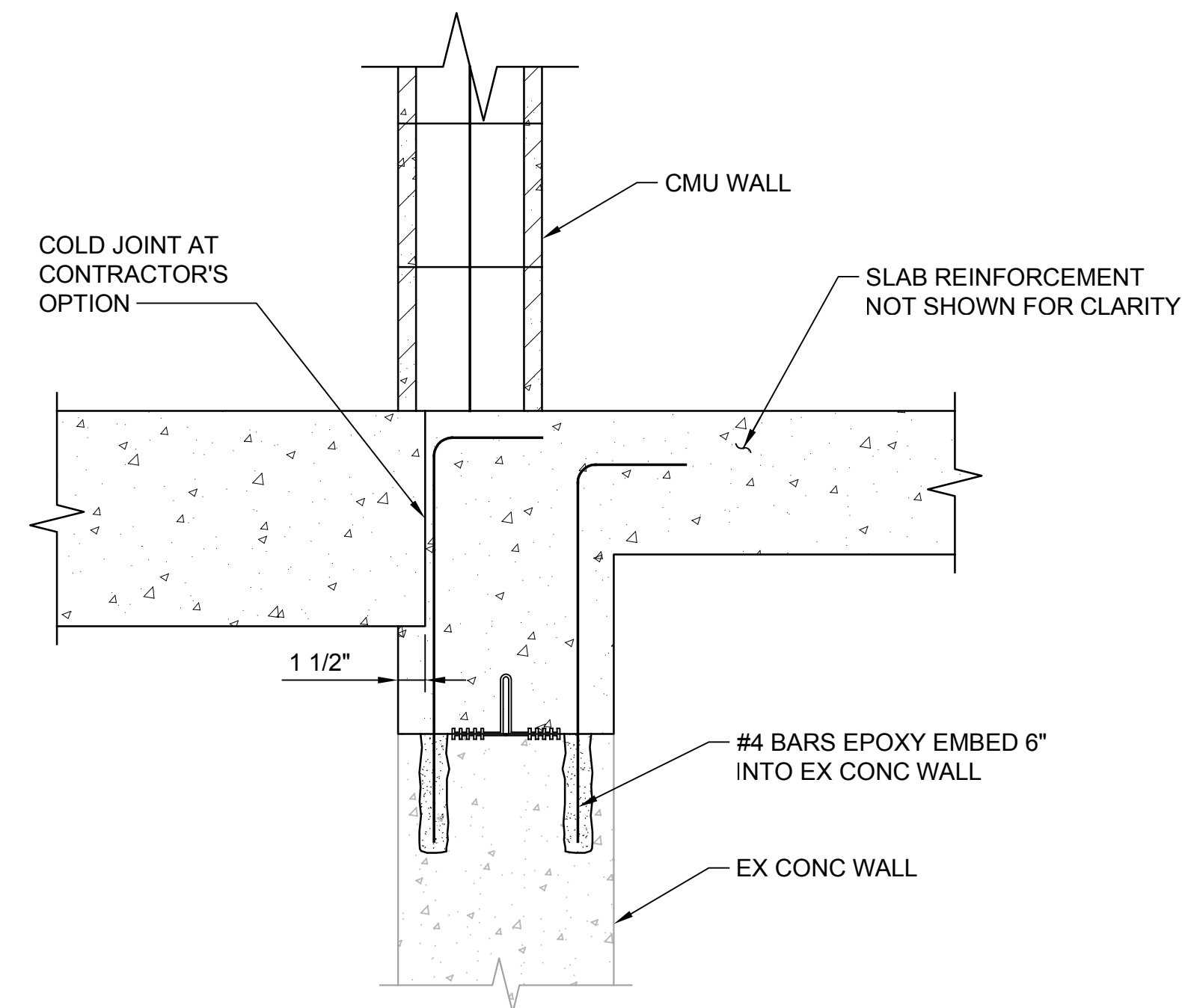

**TYPICAL CONCRETE BEAM SECTION C**

SCALE: 1 1/2" = 1'-0"

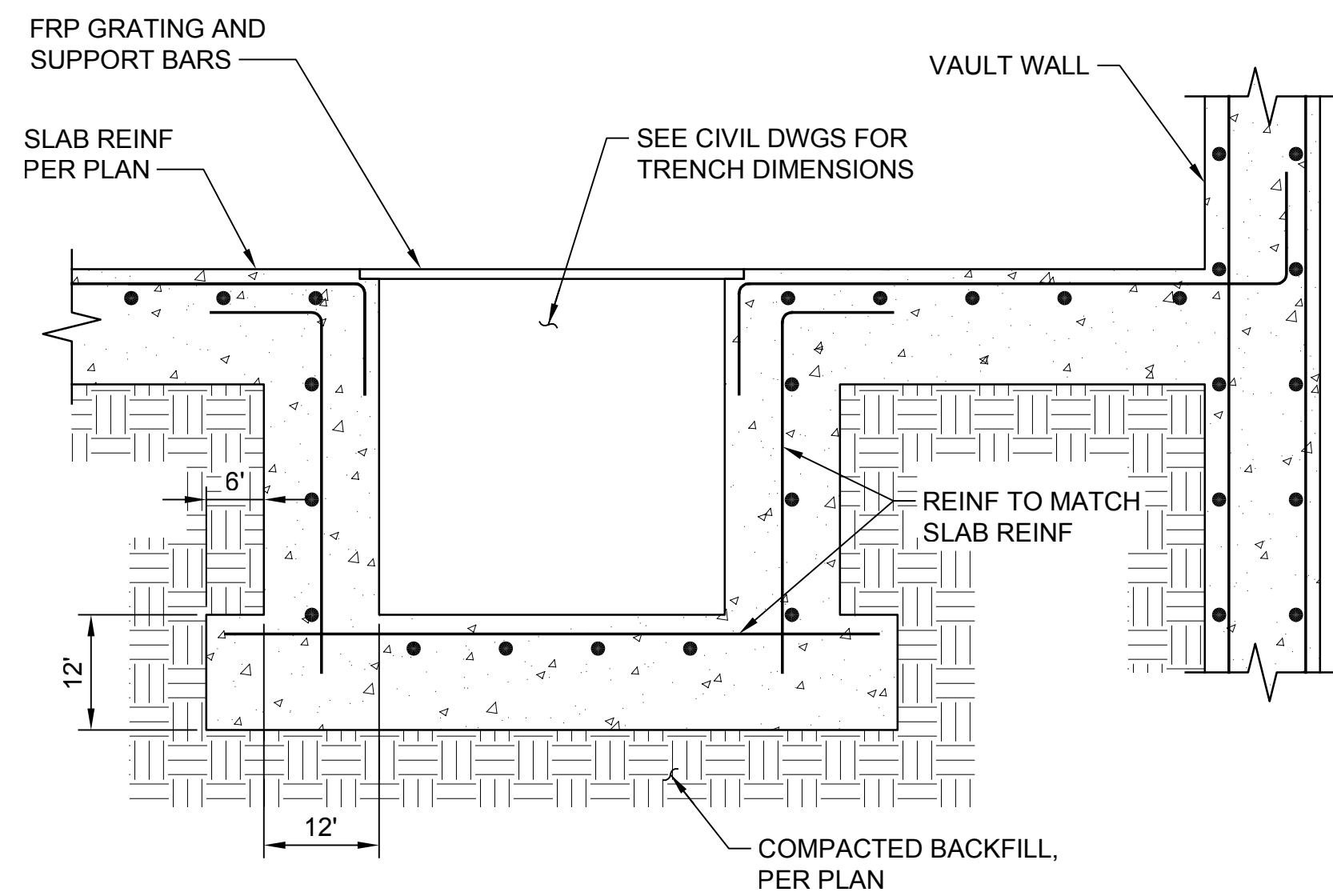

**TRENCH DRAIN SECTION D**

SCALE: 3/4" = 1'-0"

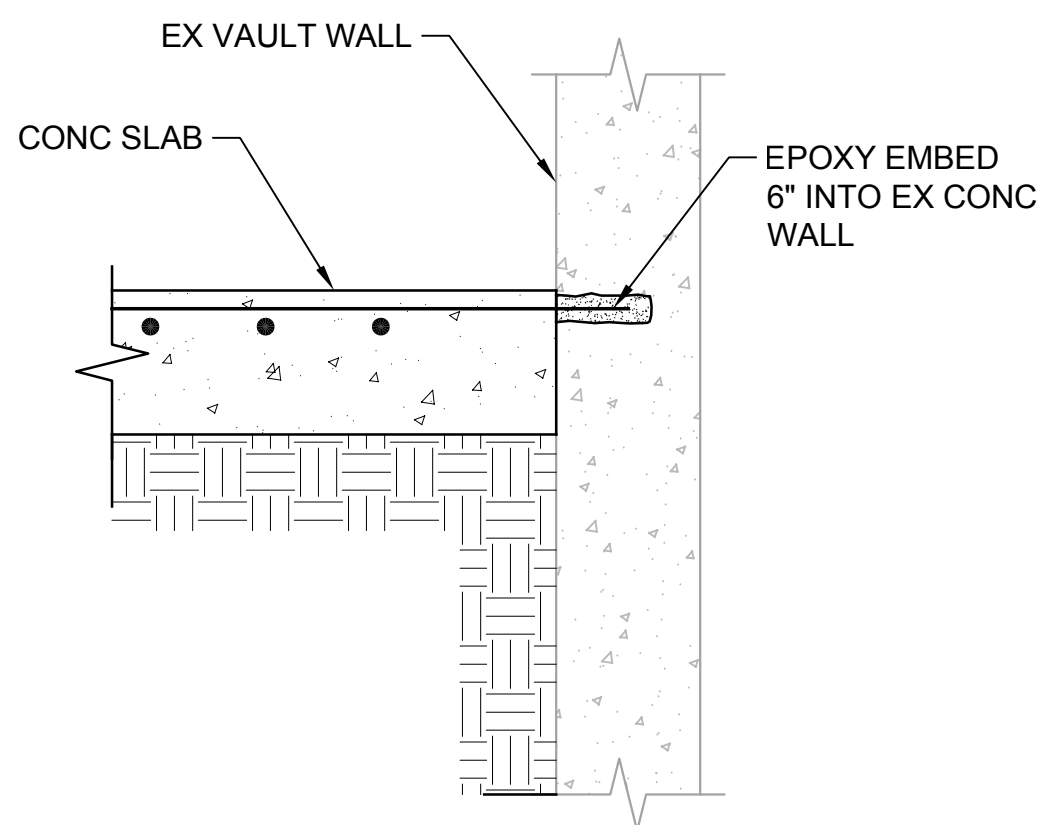

**AT EX VAULT WALL**

#7 x 6'-0" ADDED BAR AT PILASTER LOCATIONS FROM EL 115.58 TO EL 128.5  
 #5 x 6'-0" ADDED BAR AT PILASTER LOCATIONS FROM EL 128.5 TO EL 140.55  
 ALTERNATE BETWEEN TYP WALL REINFORCING

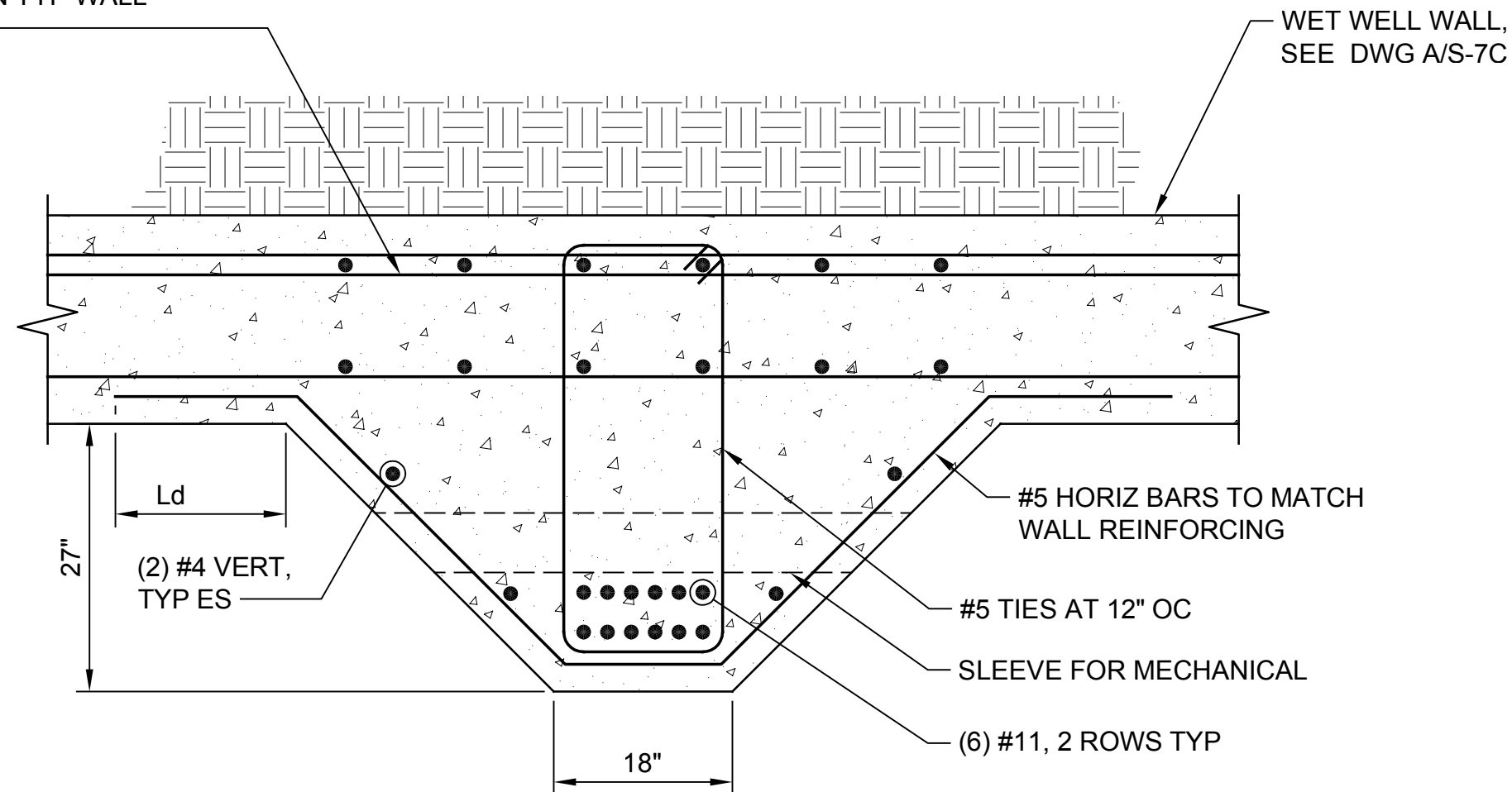

**TYPICAL CONCRETE PILASTER SECTION E**

SCALE: 3/4" = 1'-0"

**Call 48 Hours Before You Dig**

**1-800-424-5555**  
UNDERGROUND SERVICE

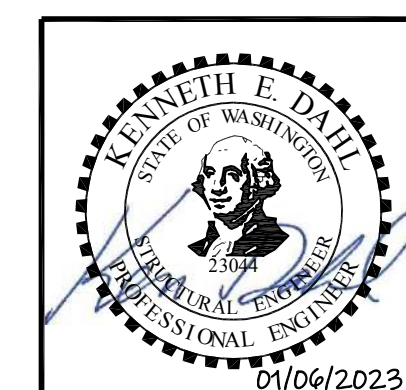

Path: S:\Cadd\Kitsap County\21-10530 Silverdale Conveyance PS 4 Uprgr\Design\Drawings\21-10530\_S-14C.dwg Plot date: Jan 06, 2023 11:37:20am CAD User: J.Lira  
 Xref Filename: 1\21-10530\_TB | Dahl | Fisher | Palmatier |

No.	Revision	Date	By	App'd
	ISSUED FOR BID	01-2023	TF	RAD



**BHC Consultants, LLC**  
 1601 Fifth Avenue, Suite 500  
 Seattle, Washington 98101  
 206.505.3400  
 206.505.3406 (fax)  
 www.bhcconsultants.com

Designed: K. Dahl, P.E., S.E.  
 Drawn: J. Lira  
 Checked: T. Fisher, P.E.

Scale:  
 As Shown  
 One Inch at Full Scale  
 If Not One Inch Scale Accordingly



**Kitsap County Public Works**  
 614 Division Street, MS 26  
 Port Orchard, WA 98366

**SILVERDALE CONVEYANCE SYSTEM AND PUMP STATION 4 UPGRADES SCHEDULE C**

**TYPICAL CONCRETE DETAILS 5 OF 6**

Drawing: **S-14C**  
 Sheet: **72** of **117**  
 File: P21-10530\_S-14C  
 Date: January 2023



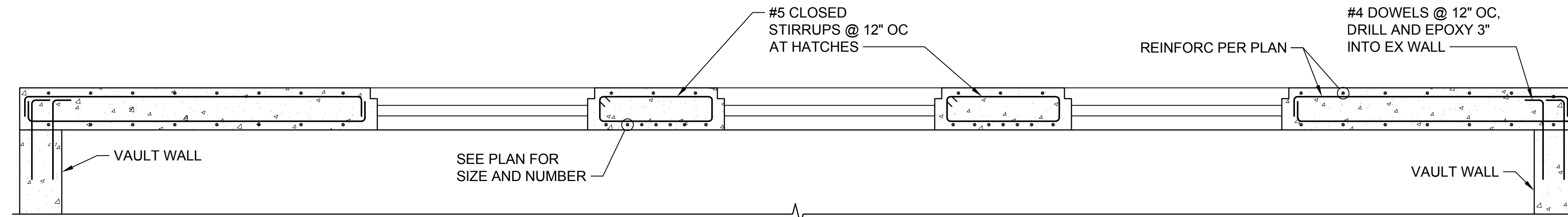

**TYPICAL CONCRETE BEAM SECTION A**  
SCALE: 1/2" = 1'-0" S-5C

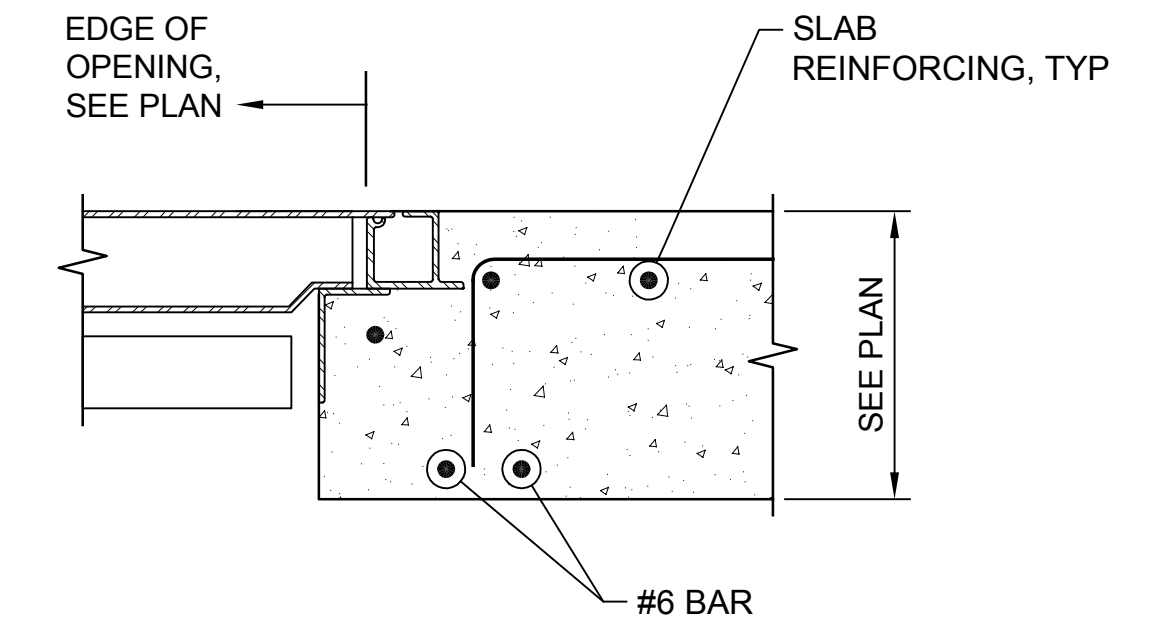

**TYPICAL OPENING EDGE DETAIL 1**  
NTS

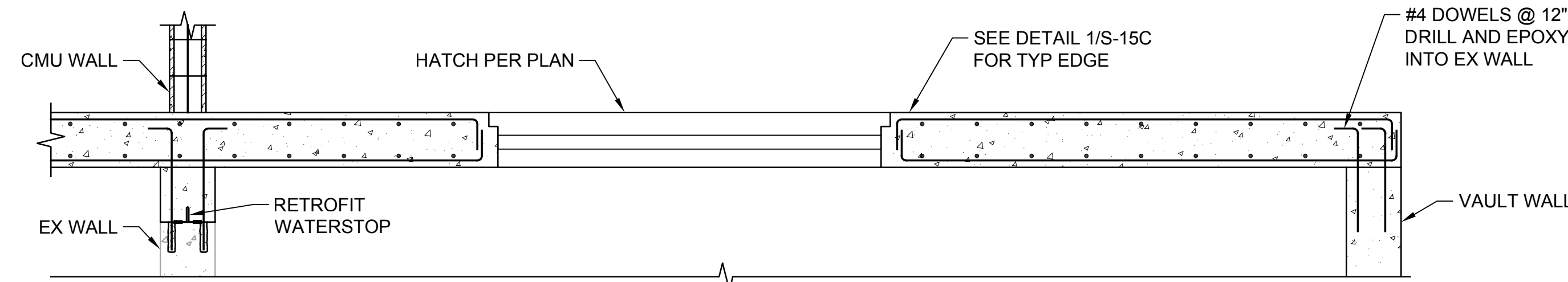

**TYPICAL CONCRETE BEAM SECTION B**  
SCALE: 1/2" = 1'-0" S-5C

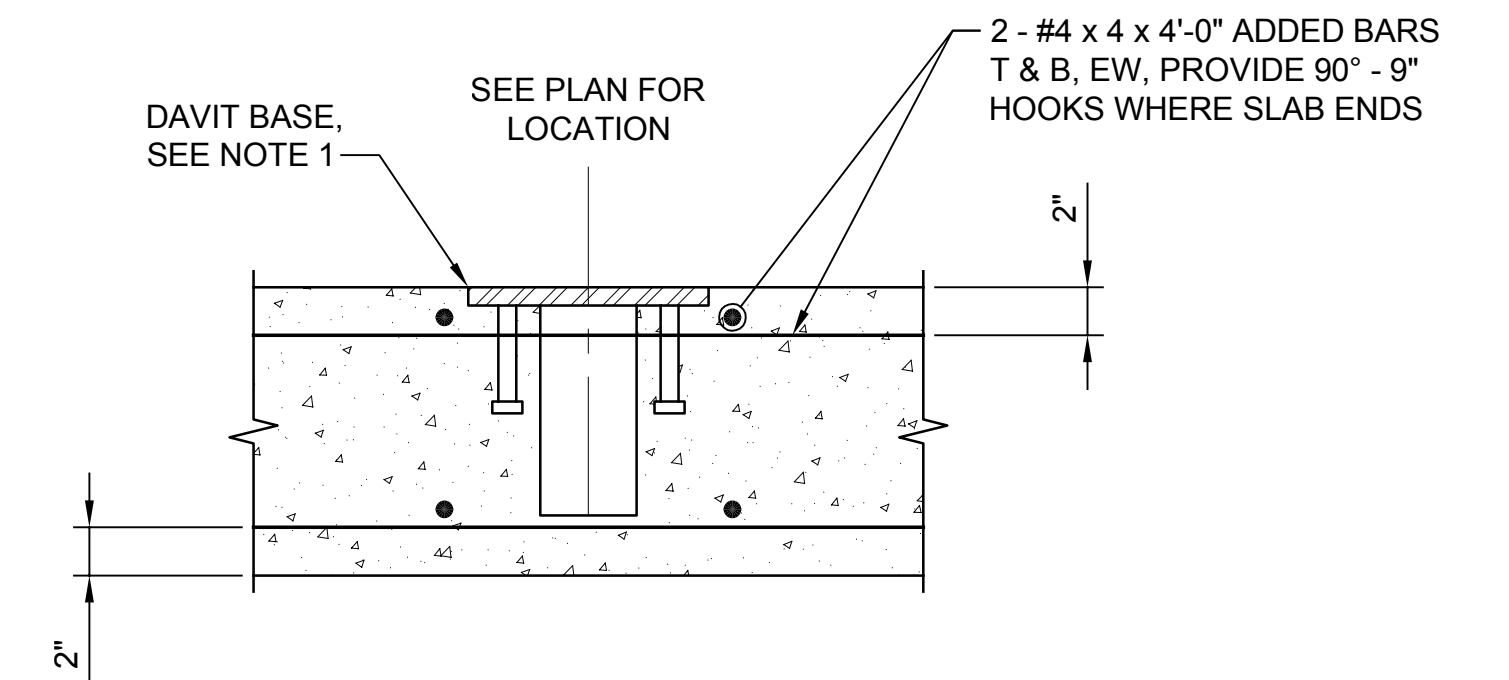

**NOTES:**  
1. DAVIT HOIST SLEEVES SHALL BE STAINLESS STEEL, 3M DBI SALA #8512328. PROVIDE MATCHING FLUSH CAP, 3M DBI SALA #851027 (H-20 RATED)

**DAVIT SLEEVE DETAIL 2**  
1 1/2" = 1'-0" TYP

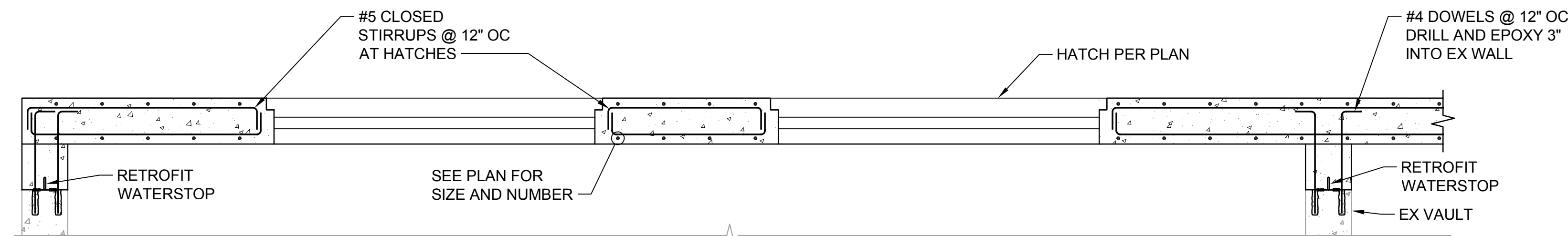

**TYPICAL CONCRETE BEAM SECTION C**  
SCALE: 1/2" = 1'-0" S-5C

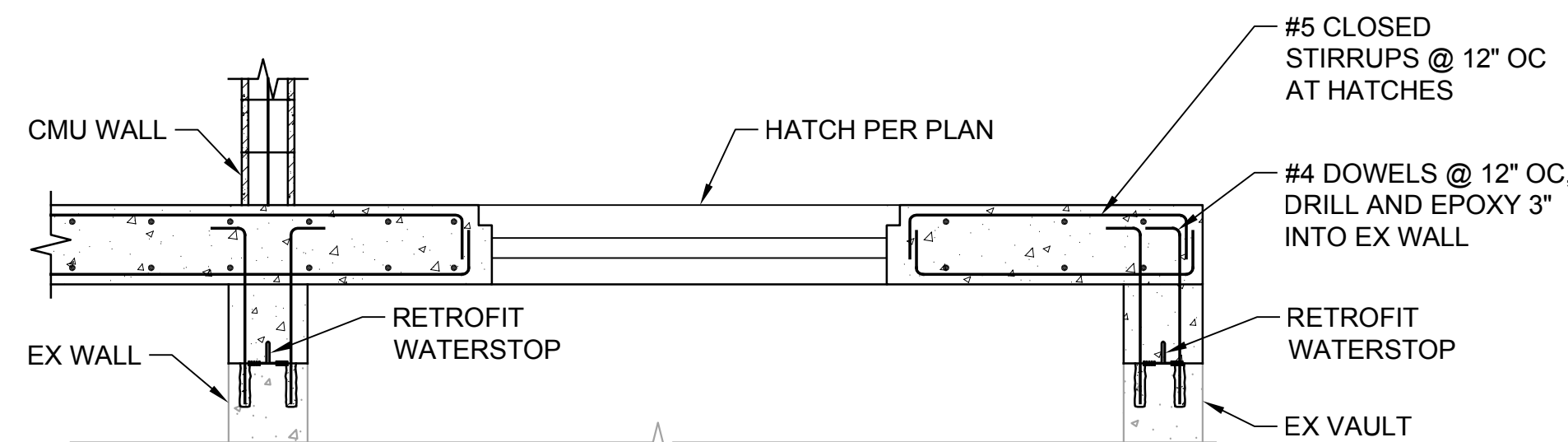

**TYPICAL CONCRETE BEAM SECTION D**  
SCALE: 1/2" = 1'-0" S-5C

**Call 48 Hours Before You Dig**

**1-800-424-5555**  
UNDERGROUND SERVICE

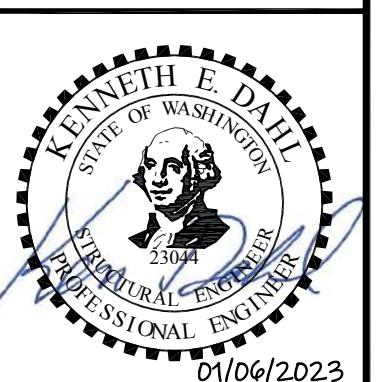

Path: S:\Cadd\Kitsap County\21-10530 Silverdale Convey-PS 4 Uprgt\Design\Drawings\21-10530\_S-15C\_Plot.dwg Plot date: Jan 06, 2023 11:39:15am CAD User: J.Lira  
Xref Filename: 21-10530\_TB | Fisher | Dan | Palmieri |

No.	Revision	Date	By	App'd
	ISSUED FOR BID	01-2023	TF	RAD

**bhc** CONSULTANTS  
BHC Consultants, LLC  
1601 Fifth Avenue, Suite 500  
Seattle, Washington 98101  
206.505.3400  
206.505.3406 (fax)  
www.bhcconsultants.com

Designed: K. Dahl, P.E., S.E.  
Drawn: J. Lira  
Checked: T. Fisher, P.E.

Scale:  
As Shown  
One Inch at Full Scale  
If Not One Inch Scale Accordingly



**Kitsap County Public Works**  
614 Division Street, MS 26  
Port Orchard, WA 98366

**SILVERDALE CONVEYANCE SYSTEM AND PUMP STATION 4 UPGRADES SCHEDULE C**

**TYPICAL CONCRETE DETAILS 6 OF 6**

Drawing: **S-15C**  
Sheet: **73** of **117**  
File: P21-10530\_S-15C  
Date: January 2023

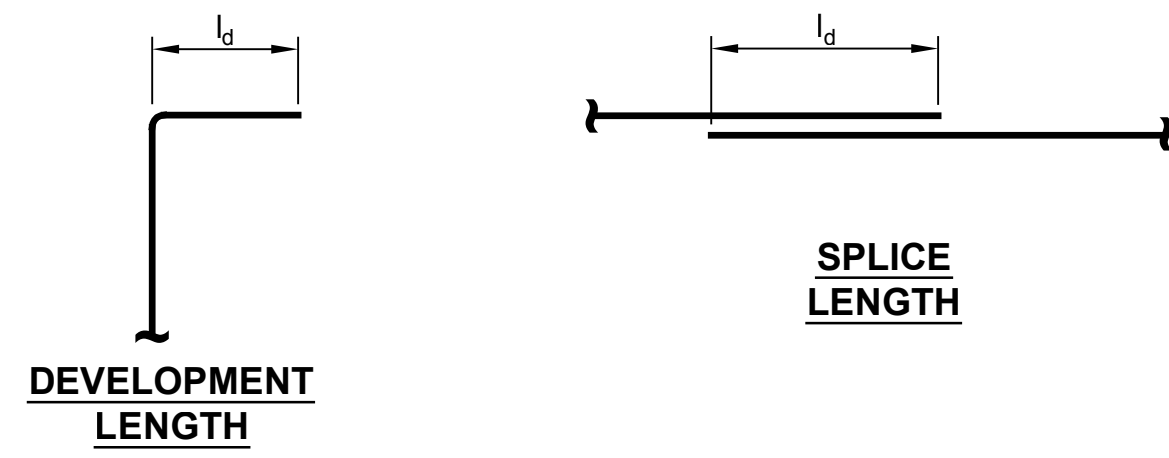

**DEVELOPMENT/SPLICE LENGTH  $l_d$  TABLE**

$f'_m = 1500$  psi

BLOCK SIZE				
BAR SIZE	6"	8"	10"	12"
#3	15"	15"	15"	15"
#4	28"	20"	20"	20"
#5	47"	29"	25"	25"
#6	94"	57"	41"	39"
#7	139"	82"	58"	46"

$f'_m = 2000$  psi

M				
BAR SIZE	6"	8"	10"	12"
#3	13"	13"	13"	13"
#4	24"	17"	17"	17"
#5	40"	25"	22"	22"
#6	82"	50"	36"	34"
#7	121"	71"	51"	40"

**MASONRY LAP SCHEDULE**

**DETAIL 1**

NTS TYP

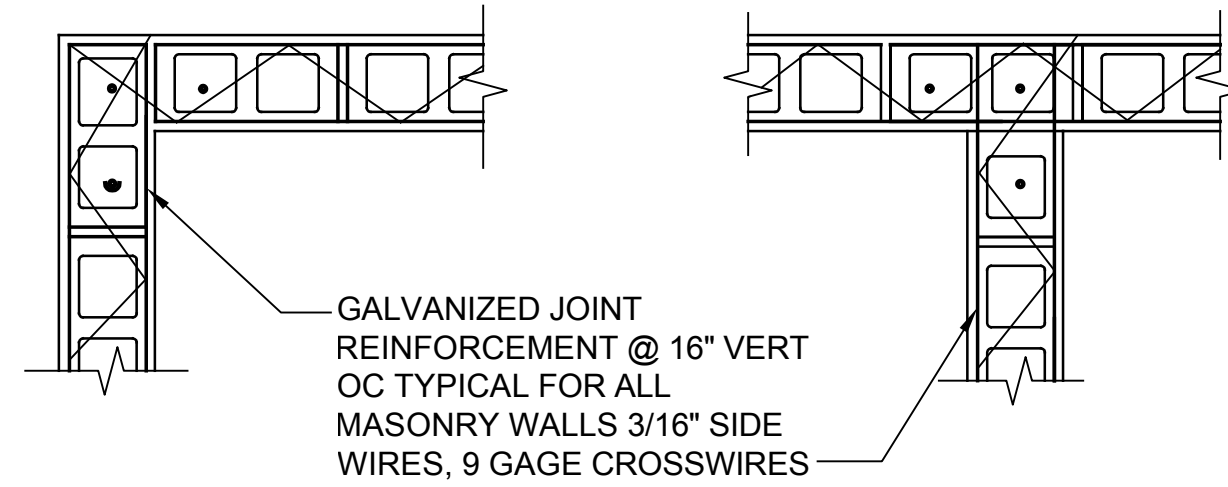

**CORNER**

**AT TEE**

**NOTES:**

1. FULL LAP AT CORNERS AND TEE INTERSECTIONS
2. LAP 9" MINIMUM AT SPLICES NOT AT TEES OR CORNERS
3. PROVIDE AT ALL WALLS IN ADDITION TO BOND BEAM REINFORCEMENT

**SUPPLEMENTAL HORIZONTAL WALL REINFORCEMENT**

**DETAIL 2**

NTS TYP

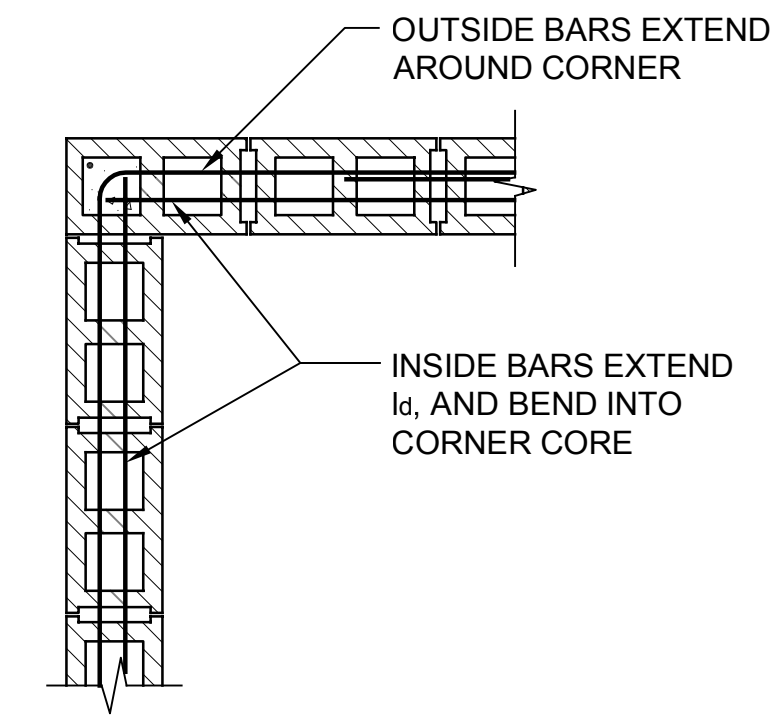

**EXTERIOR BOND BEAM**

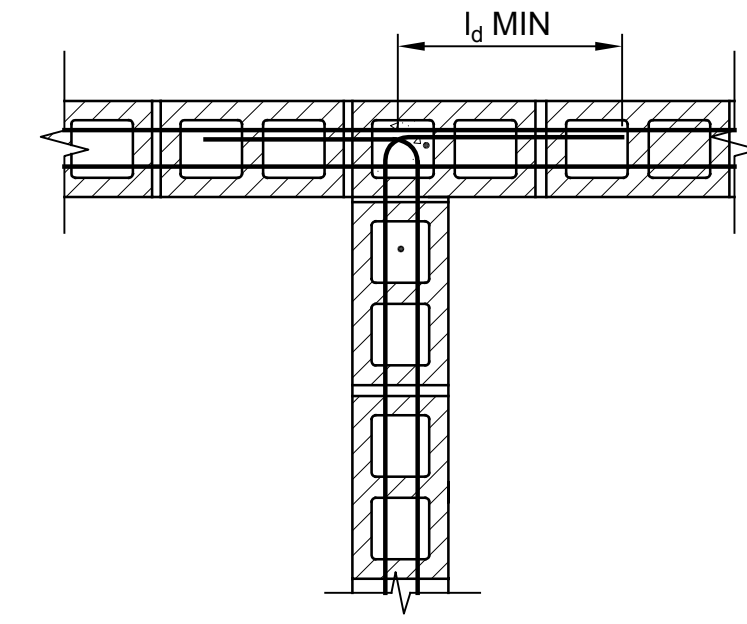

**INTERIOR BOND BEAM**

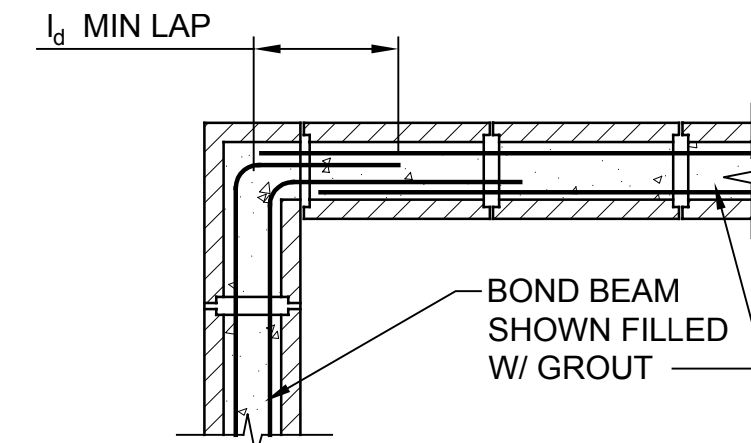

**EXTERIOR BOND BEAM**

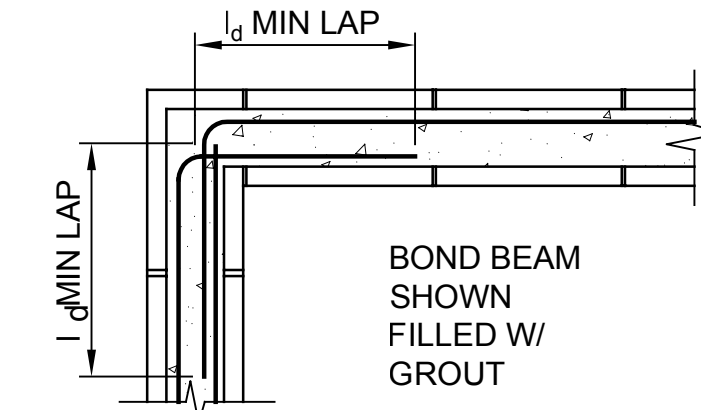

**EXTERIOR BOND BEAM**

**OPTIONAL CORNER AND WALL INTERSECTION REINFORCING LAYOUTS**

**DETAIL 3**

NTS TYP

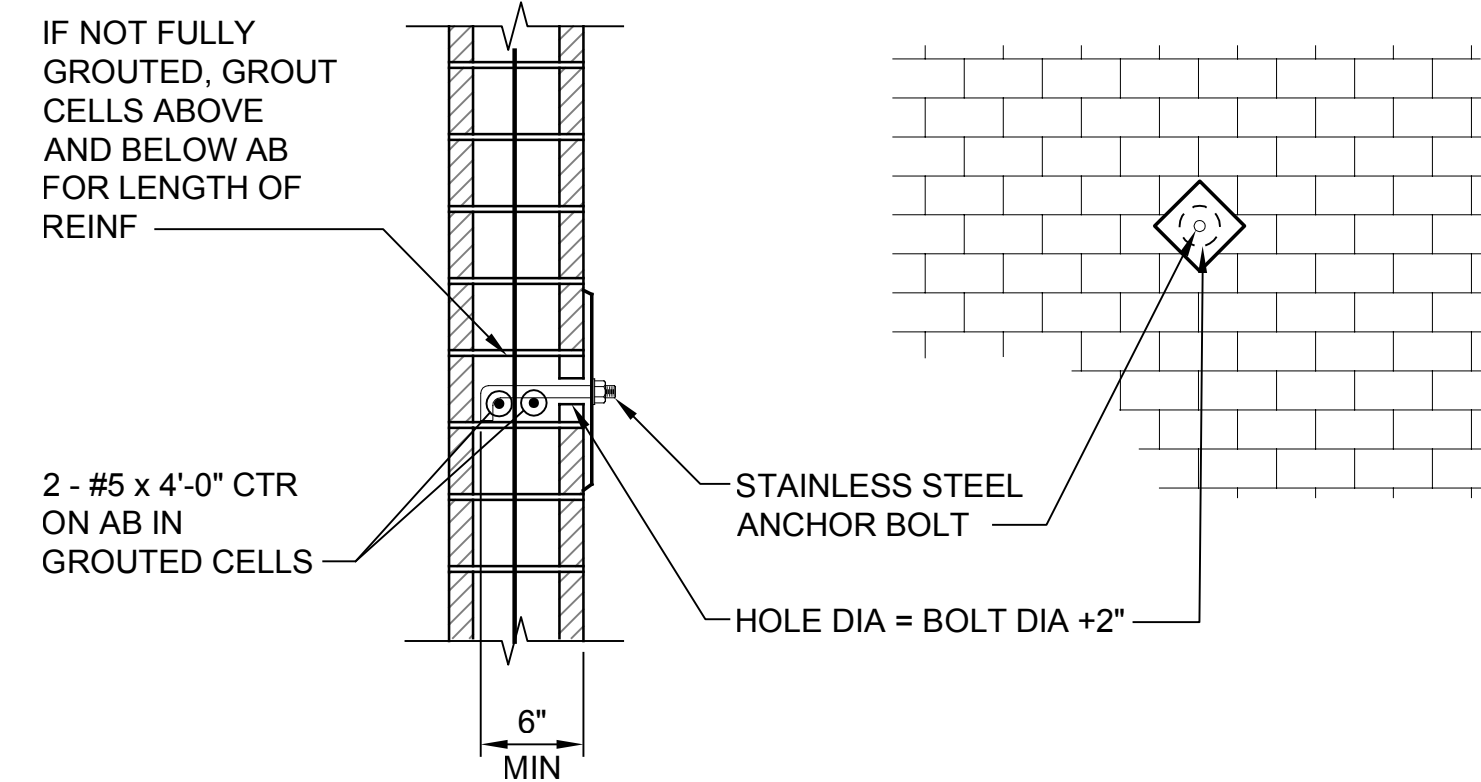

**ANCHOR BOLT IN CMU WALL**

**DETAIL 4**

NTS TYP

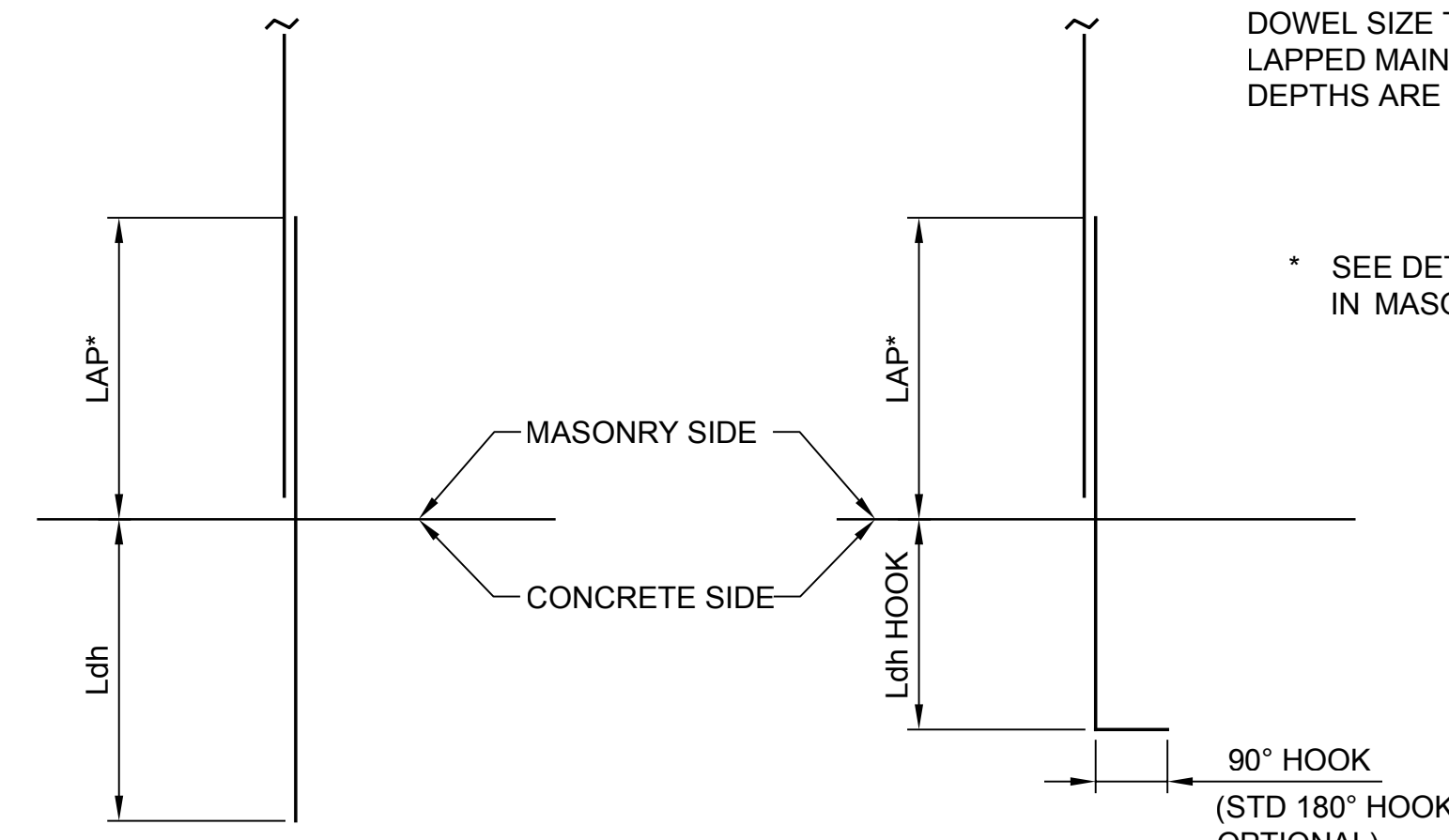

**WALL TO WALL**

**WALL TO BEAM**

**NOTE:**

DOWEL SIZE TO MATCH DIAMETER OF LAPPED MAIN BAR. LAP AND EMBEDMENT DEPTHS ARE MINIMUMS.

BAR SIZE	LAP	$L_{dh}$ HOOK
#4	18"	7"
#5	28"	7"
#6	52"	8"

\* SEE DETAIL 1/- FOR LAP LENGTHS IN MASONRY

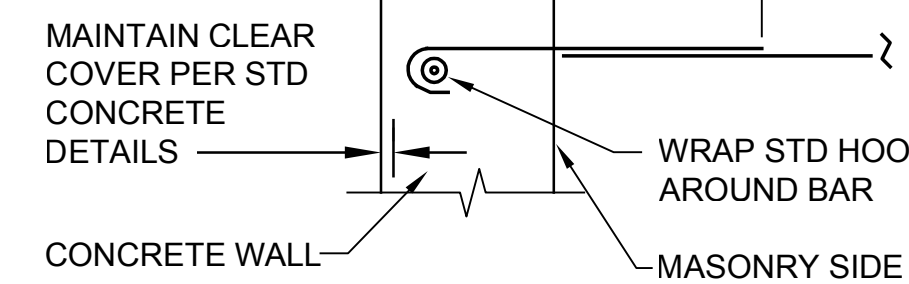

**WALL TO WALL**

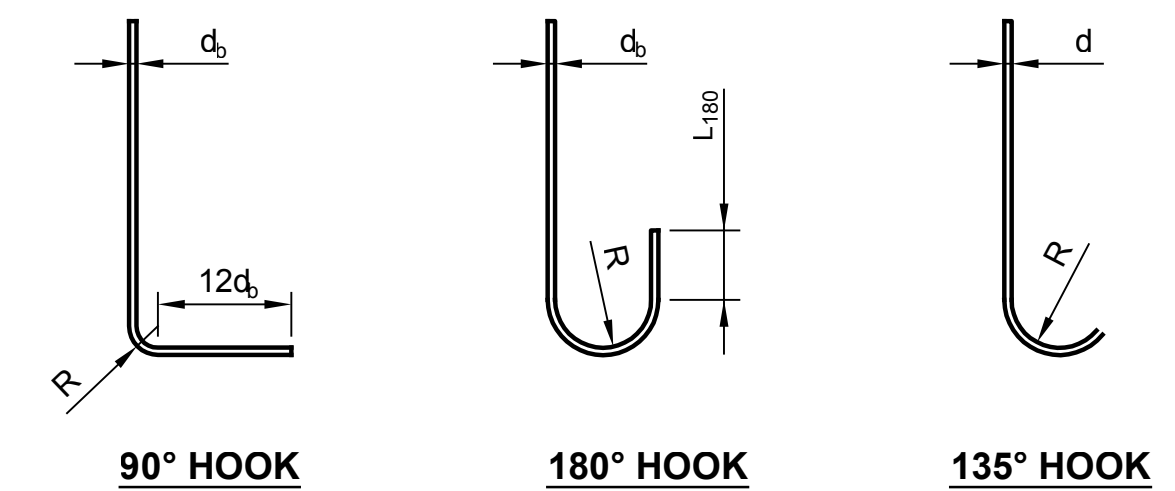

**NOTES:**

1. INSIDE RADIUS "R" =  $3 d_b$  FOR #3 THRU #8 BARS,  $4 d_b$  FOR LARGER SIZES, MINIMUM.
2.  $L_{180} = 4 d_b$  OR 21/2", WHICHEVER IS GREATER.
3.  $L_{135} = 6 d_b$  OR 4", WHICHEVER IS GREATER, EXCEPT REDUCE TO 2 1/2" MAXIMUM FOR STIRRUPS.
4. WHERE USED AS STIRRUPS, INSTEAD OF  $12 d_b$ , USE THE GREATER OF  $6 d_b$  OR 21/2" FOR 90° HOOKS.

**STANDARD MASONRY HOOKS**

**DETAIL 6**

NTS TYP

**Call 48 Hours Before You Dig**

**1-800-424-5555**  
UNDERGROUND SERVICE

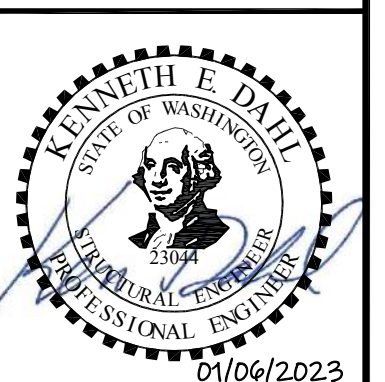

01/06/2023



**BHC Consultants, LLC**  
1601 Fifth Avenue, Suite 500  
Seattle, Washington 98101  
206.505.3400  
206.505.3406 (fax)  
www.bhcconsultants.com

Designed: K. Dahl, P.E., S.E.

Drawn: A. Bradley

Checked: T. Fisher, P.E.

Scale:

NTS

One Inch at Full Scale  
If Not One Inch Scale Accordingly



**Kitsap County Public Works**

614 Division Street, MS 26  
Port Orchard, WA 98366

**SILVERDALE CONVEYANCE SYSTEM AND PUMP STATION 4 UPGRADES SCHEDULE C**

**TYPICAL MASONRY DETAILS**

**1 OF 2**

Drawing: **S-16C**

Sheet: **74** of **117**

File: P21-10530-PS4\_S-16C

Date: January 2023

Path: S:\CAD\Kitsap County\21-10530 Silverdale Conveyance-PS 4 UprdtDesign\Drawings\21-10530\_S-17C.dwg Plot date: Jan 06, 2023 11:42:37am CAD User: J. Jira  
 Xref Filename: 21-10530-PS\_4\_TB | Fisher | Dahl | Palmatier

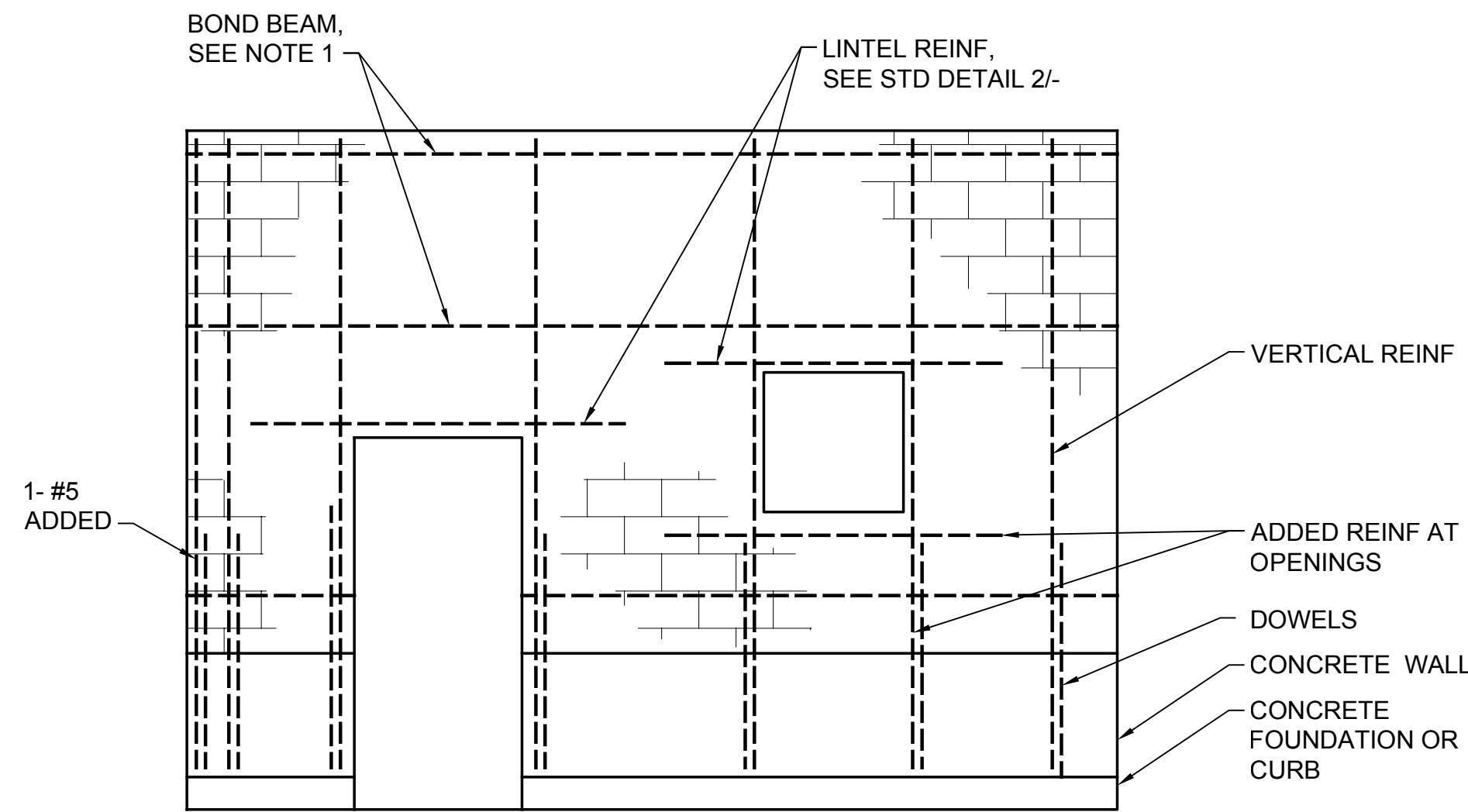

- NOTES:**
1. PROVIDE BOND BEAMS WITH 2-#4 CONT AT 48" VERT SPACING MAX AND AT TOPS AND BOTTOMS OF WALLS, UNLESS NOTED OTHERWISE.
  2. LAP SPLICES PER DETAIL 1/S19-7.
  3. PROVIDE DOWEL BARS IN CONCRETE TO MATCH ALL VERTICAL CMU REINFORCING.
  4. GROUT ALL CELLS WITH REINFORCING.
  5. SEE DETAIL 4/- FOR SLOPED TOP CONDITIONS.

**TYPICAL CMU WALL, UNO  
ELEVATION 1**  
NTS TYP

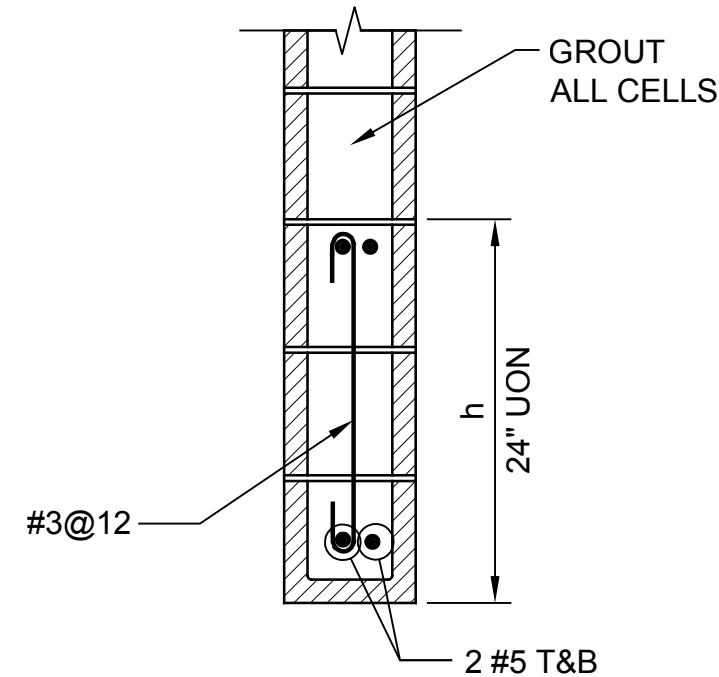

- NOTES:**
1. EXTEND HORIZONTAL REINFORCING A MINIMUM OF 2'-0" BEYOND BEARING. WHERE THE OPENING BEGINS LESS THAN 2' FROM A CORNER, HOOK THE BOTTOM REINFORCING UP 6" AT THE CORNER.
  2. ALTERNATE DIRECTION OF STIRRUPS.

**LINTEL  
DETAIL 2**  
NTS

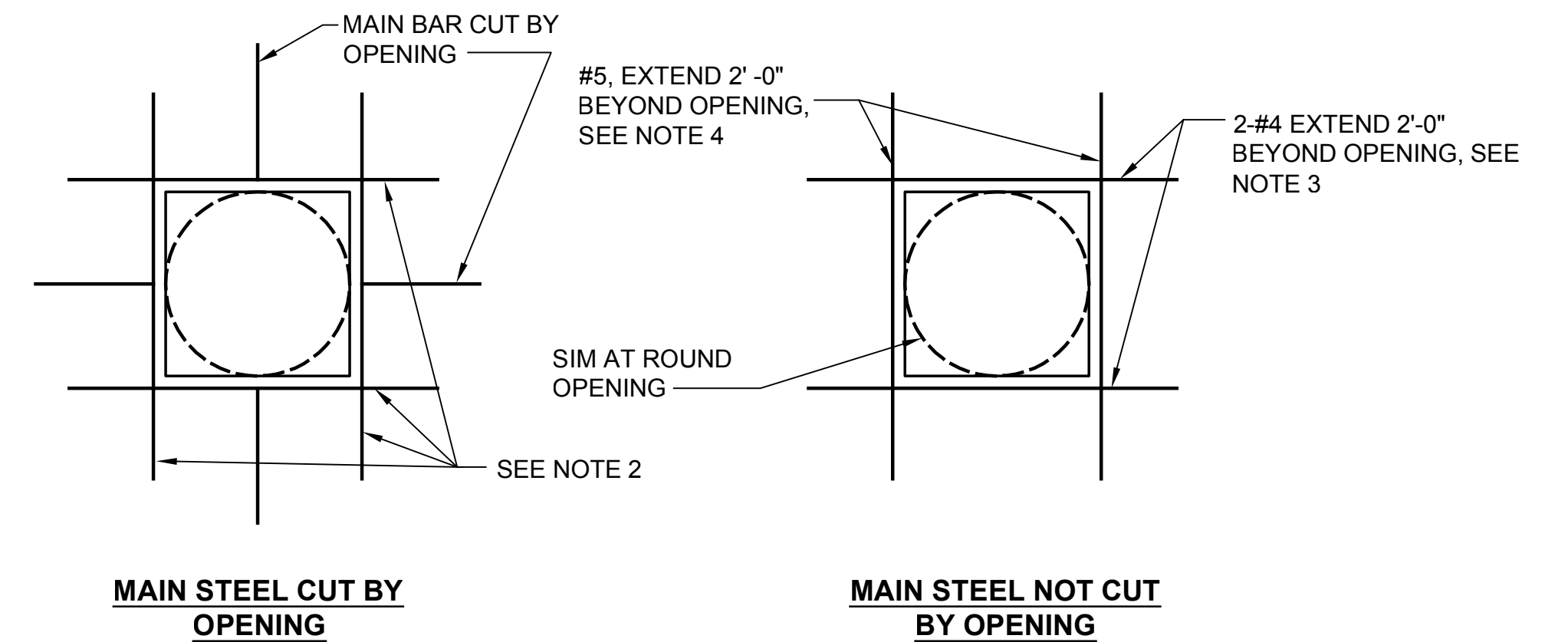

- NOTES:**
1. THIS DETAIL IS APPLICABLE TO MISCELLANEOUS WALL PENETRATIONS NOT GREATER THAN 24" IN MAXIMUM HORIZONTAL OR VERTICAL DIMENSION AND NOT OTHERWISE DETAILED ON THE MASONRY ELEVATIONS, SEE DETAIL 2/- FOR LINTELS GREATER THAN 2'-0" SPAN.
  2. ADD FULL LENGTH BARS WITH STEEL AREA NOT LESS THAN HALF OF CUT BAR, PARALLEL TO CUT BAR IN CELLS CLOSEST TO OPENING, #5 MINIMUM.
  3. HORIZONTAL TRIM NOT REQUIRED ABOVE OR BELOW OPENING IN CELLS ALREADY REINFORCED WITH BOND BEAM STEEL.
  4. VERTICAL TRIM NOT REQUIRED IN JAMB CELLS ALREADY REINFORCED WITH VERTICAL BARS.

**OPENING REINFORCEMENT  
DETAIL 3**  
NTS TYP

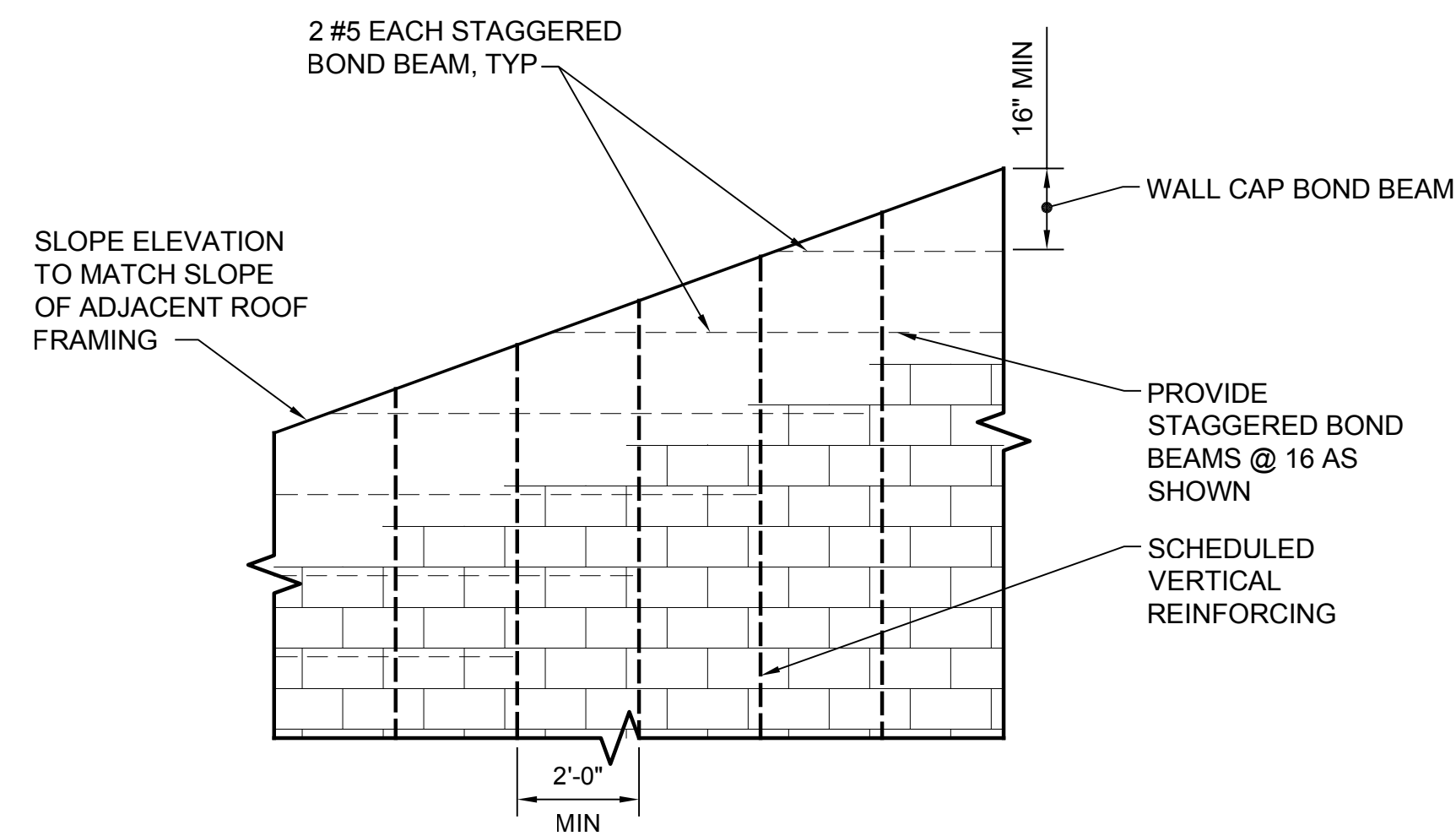

**TYP SLOPED WALL  
STAGGERED BOND BEAMS  
DETAIL 4**  
NTS TYP

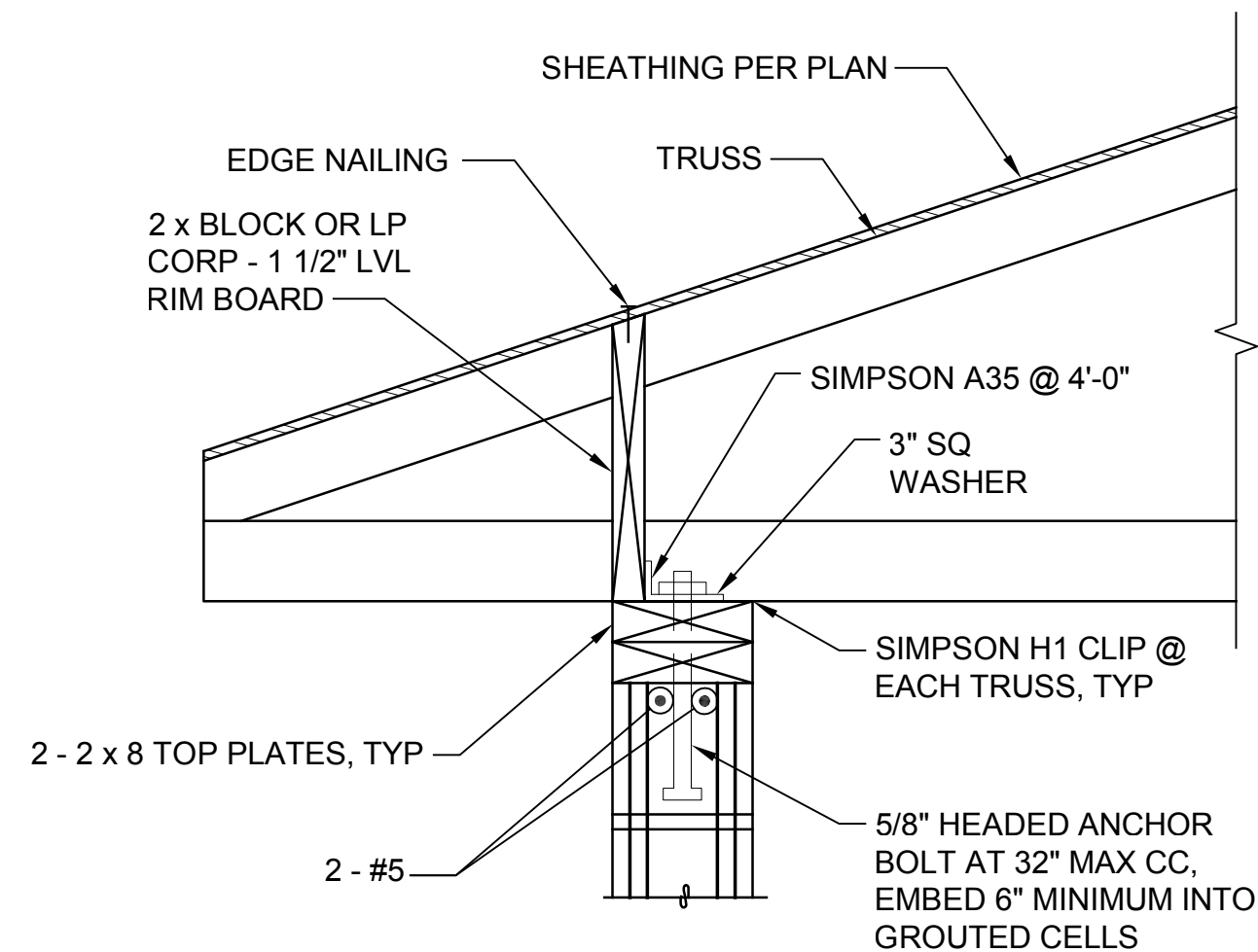

- NOTES:**
1. SEE STRUCTURAL GENERAL NOTES FOR REQUIREMENTS FOR FASTENERS, ANCHORS, AND CONNECTORS IN CONTACT WITH TREATED WOOD.

**TYPICAL ROOF CONNECTION  
SECTION A**  
NTS S-9D

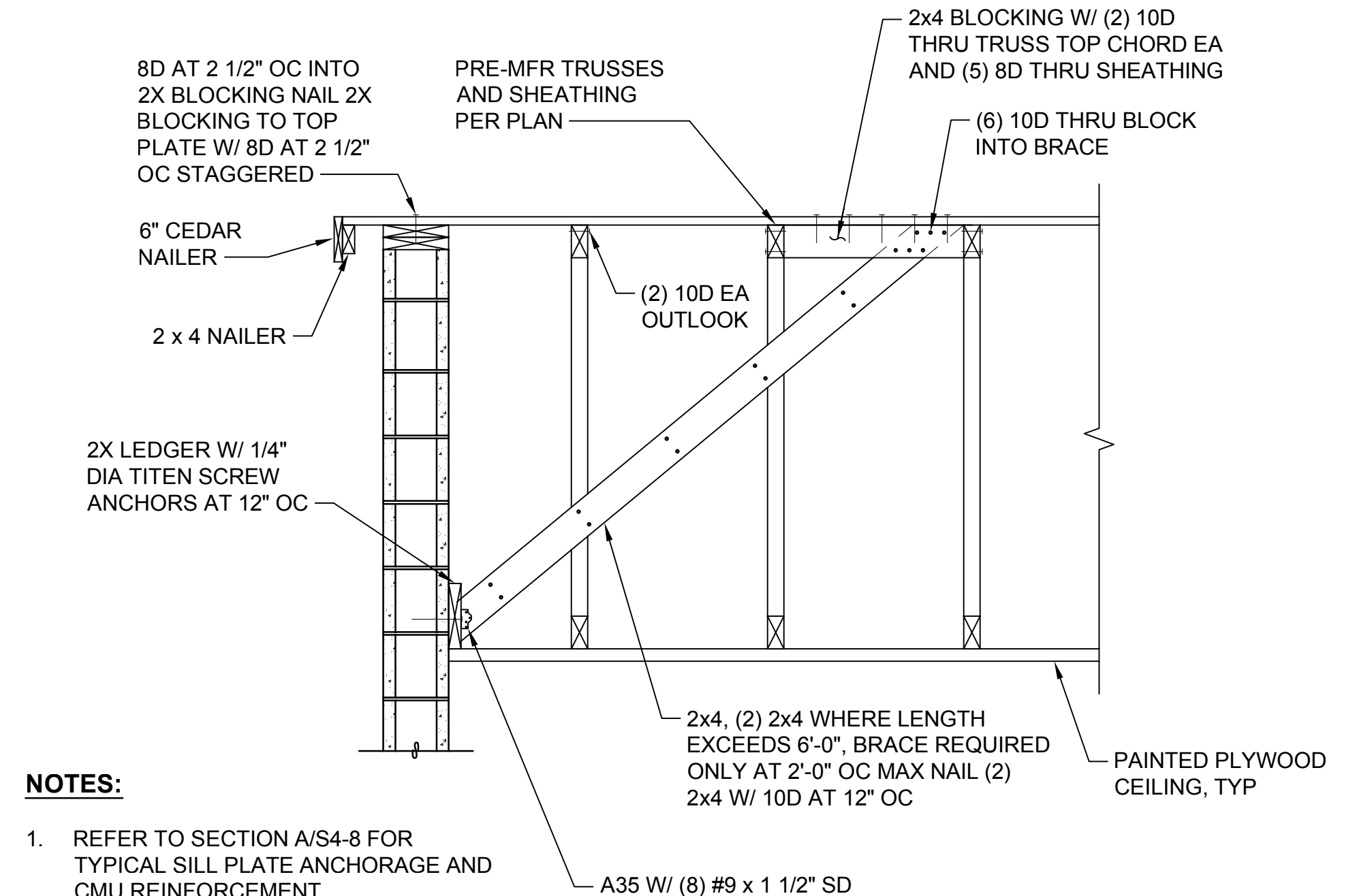

- NOTES:**
1. REFER TO SECTION A/S4-8 FOR TYPICAL SILL PLATE ANCHORAGE AND CMU REINFORCEMENT.

**TYPICAL ROOF CONNECTION  
SECTION B**  
NTS S-7D

**Call 48 Hours  
Before You Dig**  
1-800-424-5555  
UNDERGROUND SERVICE

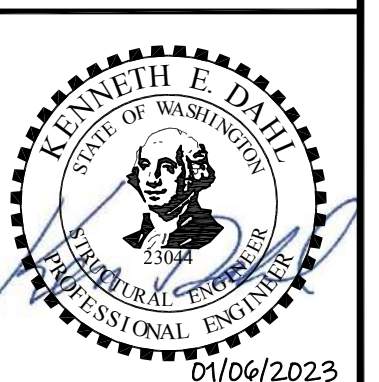

No.	Revision	Date	By	App'd
		01-2023	TF	RAD
	ISSUED FOR BID			

**bhc** CONSULTANTS  
**BHC Consultants, LLC**  
 1601 Fifth Avenue, Suite 500  
 Seattle, Washington 98101  
 206.505.3400  
 206.505.3406 (fax)  
 www.bhcconsultants.com

Designed: K. Dahl, P.E., S.E.  
 Drawn: A. Bradley  
 Checked: T. Fisher, P.E.

Scale:  
 NTS  
 One Inch at Full Scale  
 If Not One Inch  
 Scale Accordingly



**Kitsap County Public Works**  
 614 Division Street, MS 26  
 Port Orchard, WA 98366

**SILVERDALE CONVEYANCE SYSTEM AND PUMP STATION 4 UPGRADES  
SCHEDULE C**  
**TYPICAL MASONRY DETAILS**  
**2 OF 2**

Drawing: **S-17C**  
 Sheet: **75** of **117**  
 File: P21-10530\_S-17C  
 Date: January 2023

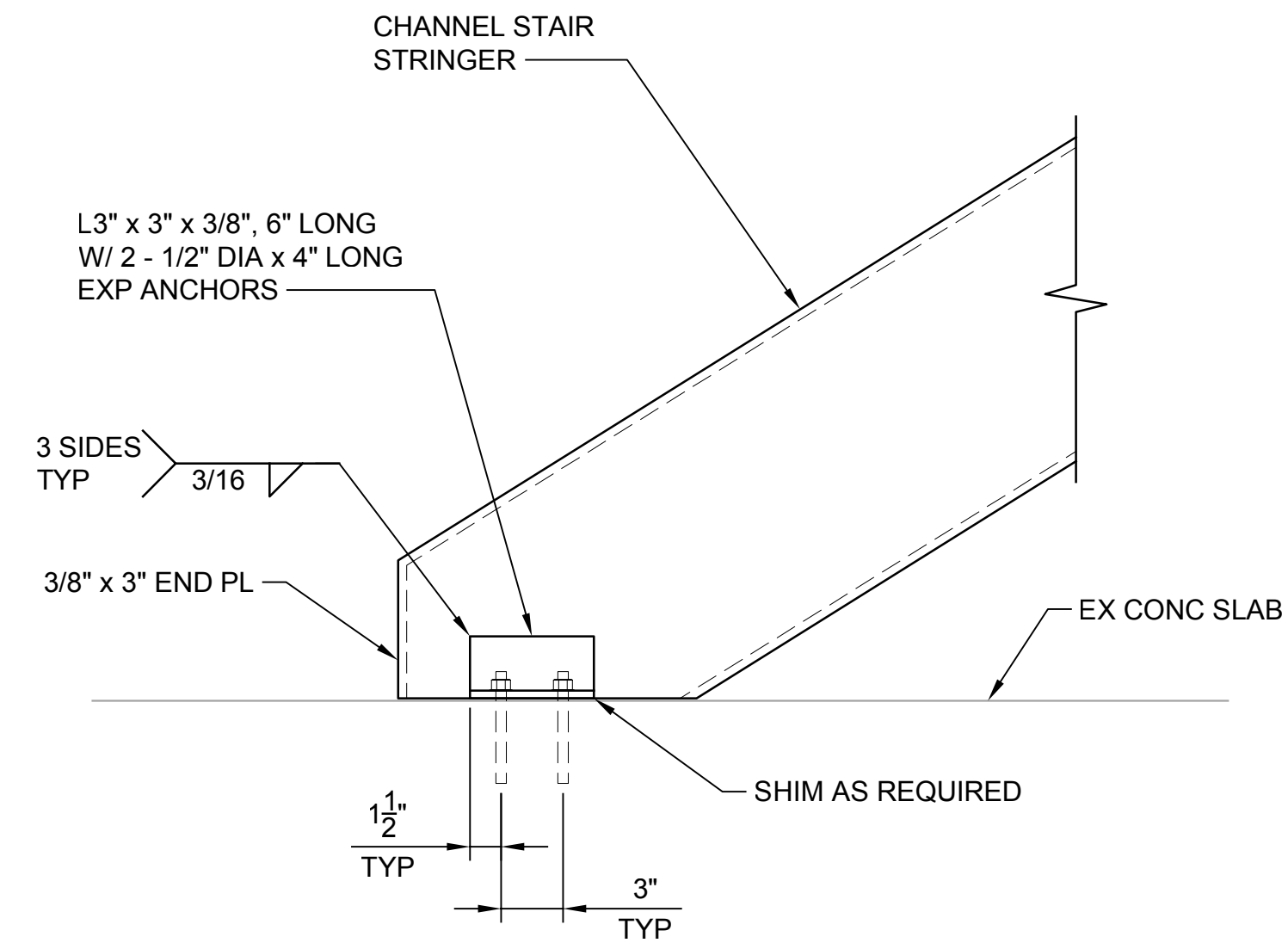

**STAIR CONNECTION  
AT EXISTING SLAB  
DETAIL**

NTS 1 TYP

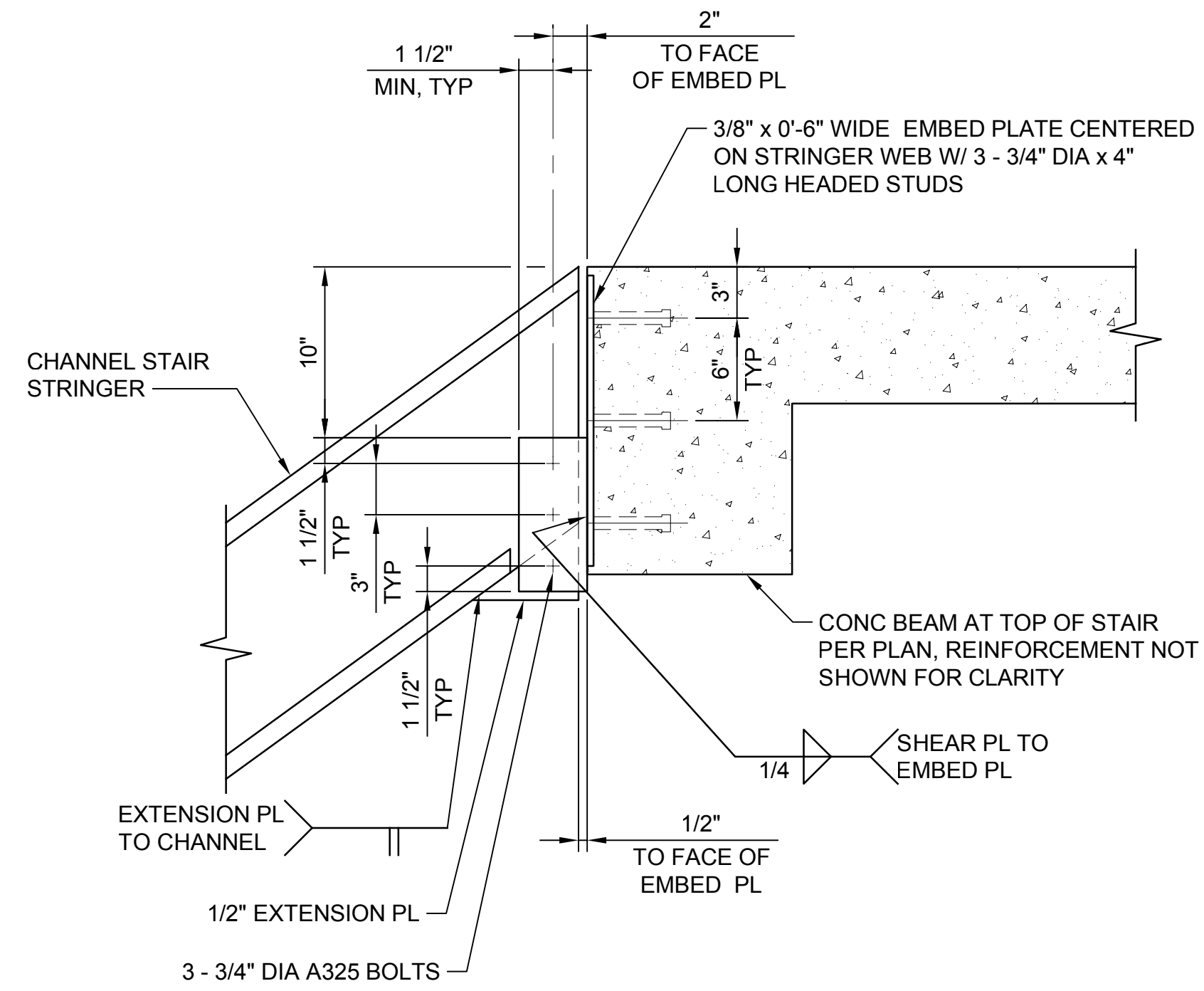

**STAIR CONNECTION  
AT CONCRETE BEAM  
DETAIL**

NTS 2 TYP

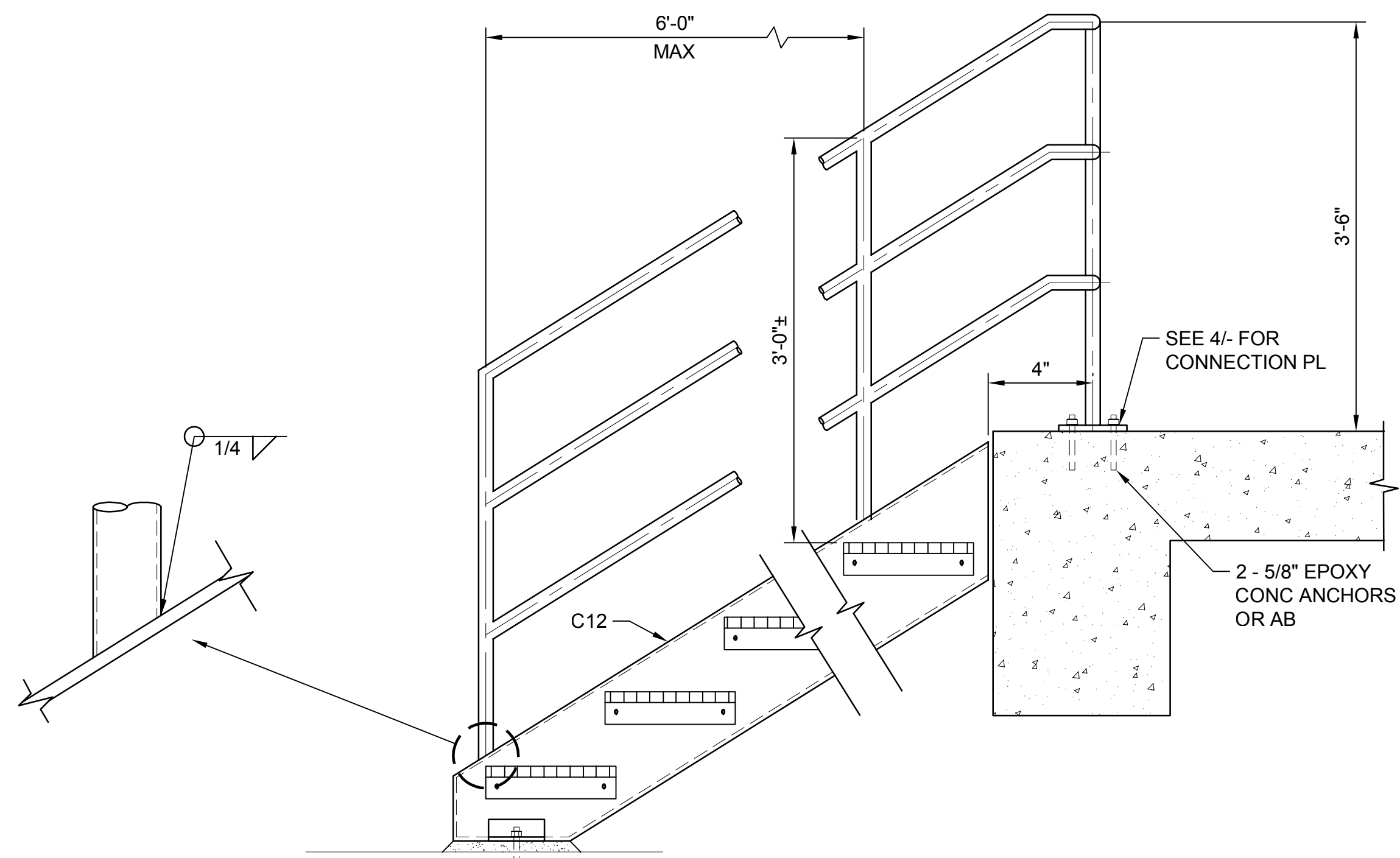

**STAIR RAILING  
CONNECTION  
DETAIL**

NTS 3 TYP

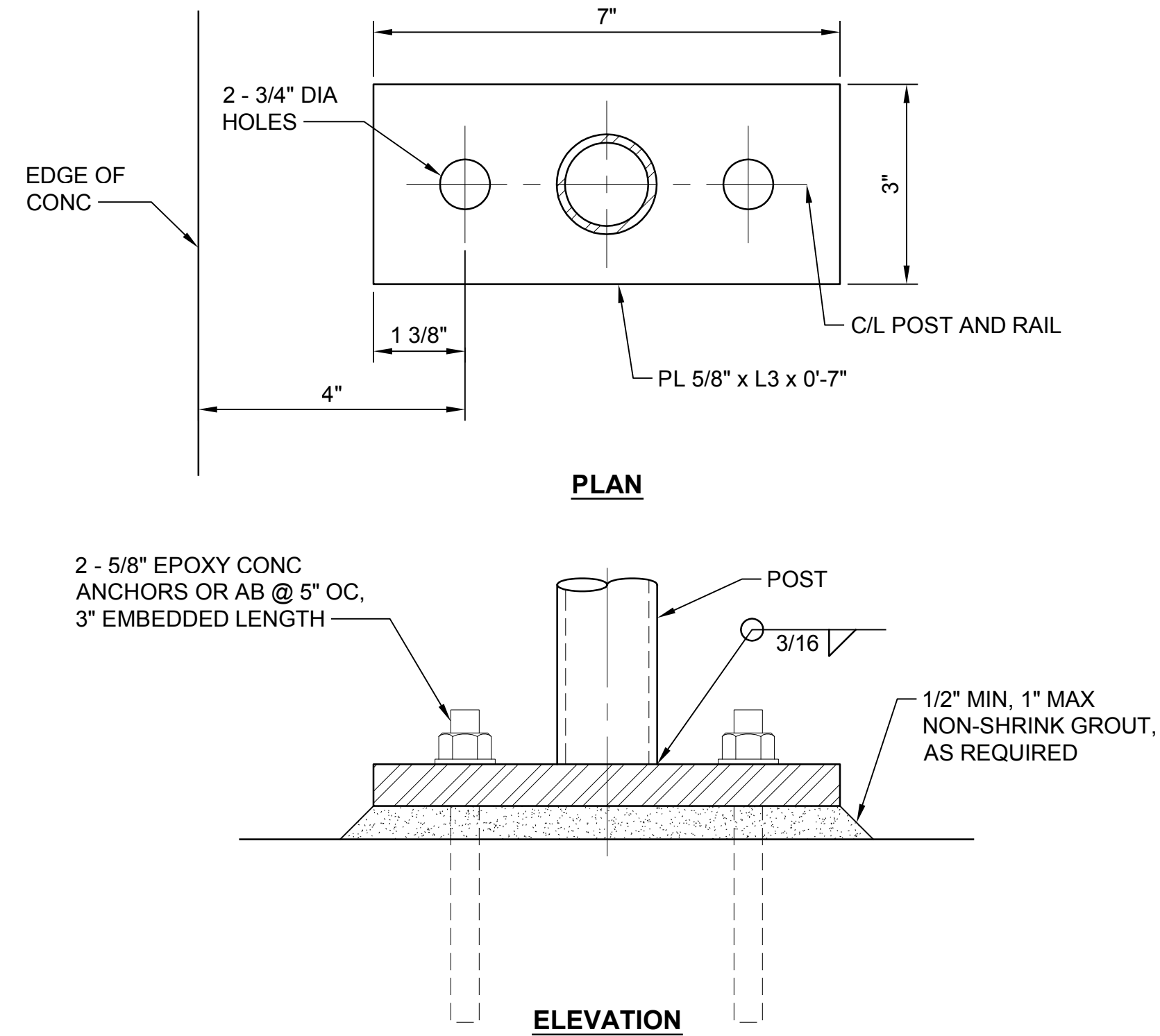

**STAIR RAILING  
CONNECTION TO CONCRETE  
DETAIL**

NTS 4 TYP

Path: S:\CAD\Kitsap County\21-10530 Silverdale Convey-PS 4 Upgr\Design\Drawings\21-10530-S-18C-PS4\_TB.dwg Plot date: Jan 06, 2023 11:44:13am CAD User: J.Lira  
Xref Filename: 21-10530-PS4\_TB.dwg | Fisher | Dahl | Palmatier

**Call 48 Hours  
Before You Dig**  
1-800-424-5555  
UNDERGROUND SERVICE



Drawing: **S-18C**  
Sheet: **76** of **117**  
File: P21-10530-PS4\_S-18C  
Date: January 2023

No.	Revision	Date	By	App'd
	ISSUED FOR BID	01-2023	TF	RAD

**bhc**  
CONSULTANTS

**BHC Consultants, LLC**  
1601 Fifth Avenue, Suite 500  
Seattle, Washington 98101  
206.505.3400  
206.505.3406 (fax)  
www.bhcconsultants.com

Designed: K. Dahl, P.E., S.E.  
Drawn: J. Lira  
Checked: T. Fisher, P.E.

Scale:  
NTS  
One Inch at Full Scale  
If Not One Inch Scale Accordingly



**Kitsap County Public Works**  
614 Division Street, MS 26  
Port Orchard, WA 98366

**SILVERDALE CONVEYANCE SYSTEM AND PUMP STATION 4 UPGRADES  
SCHEDULE C**

**TYPICAL STAIR DETAILS**

Path: S:\Cadd\Kitsap County\21-10530 Silverdale Conveyance\PS-4 Uprgt\Design\Drawings\21-10530\_S-19C\_Plot.dwg; Plot date: Jan 06, 2023 11:45:55am; CAD User: J.Lira; Xref Filename: 21-10530-PS-4\_TB | Dahl | Fisher | Palmatier

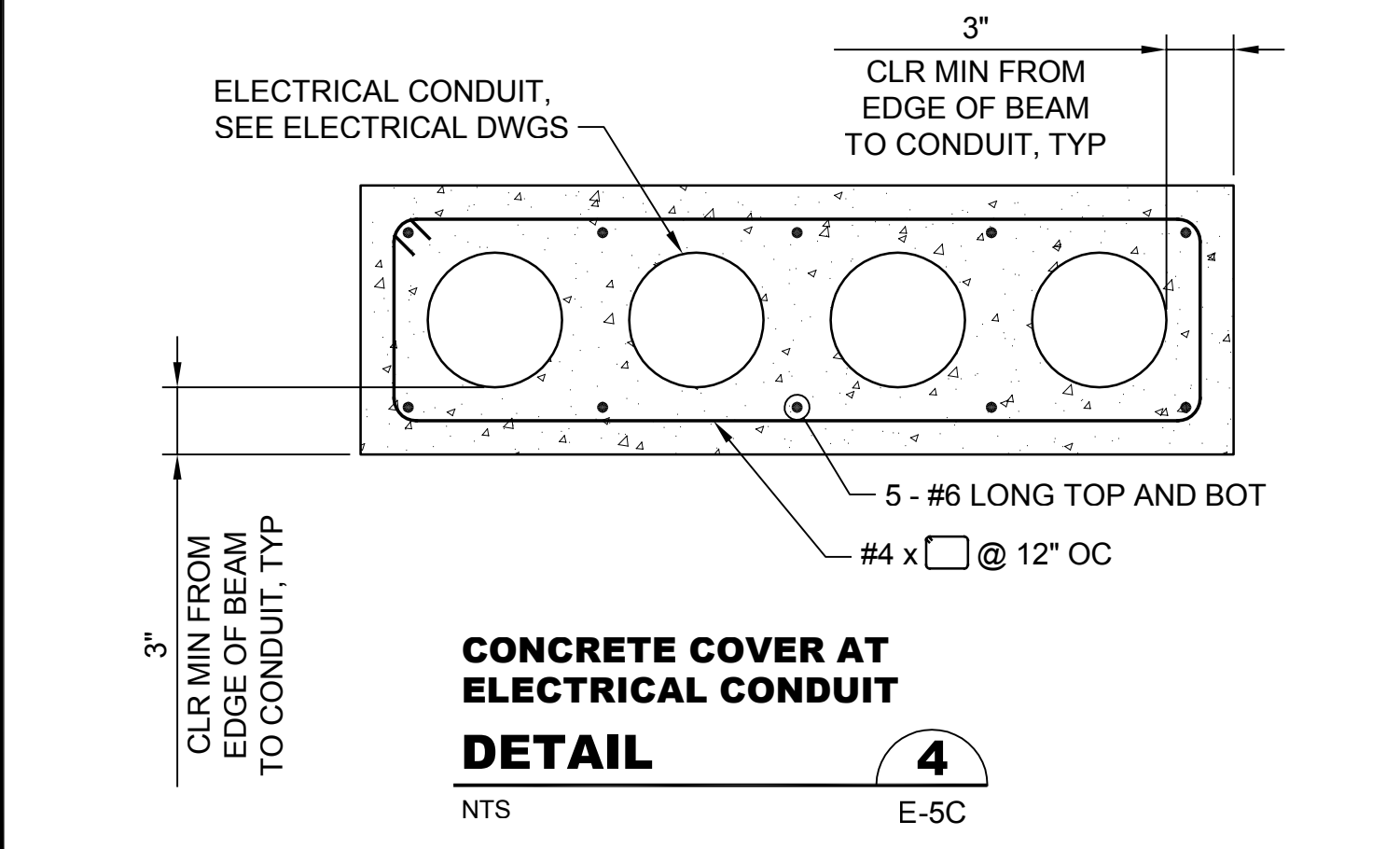
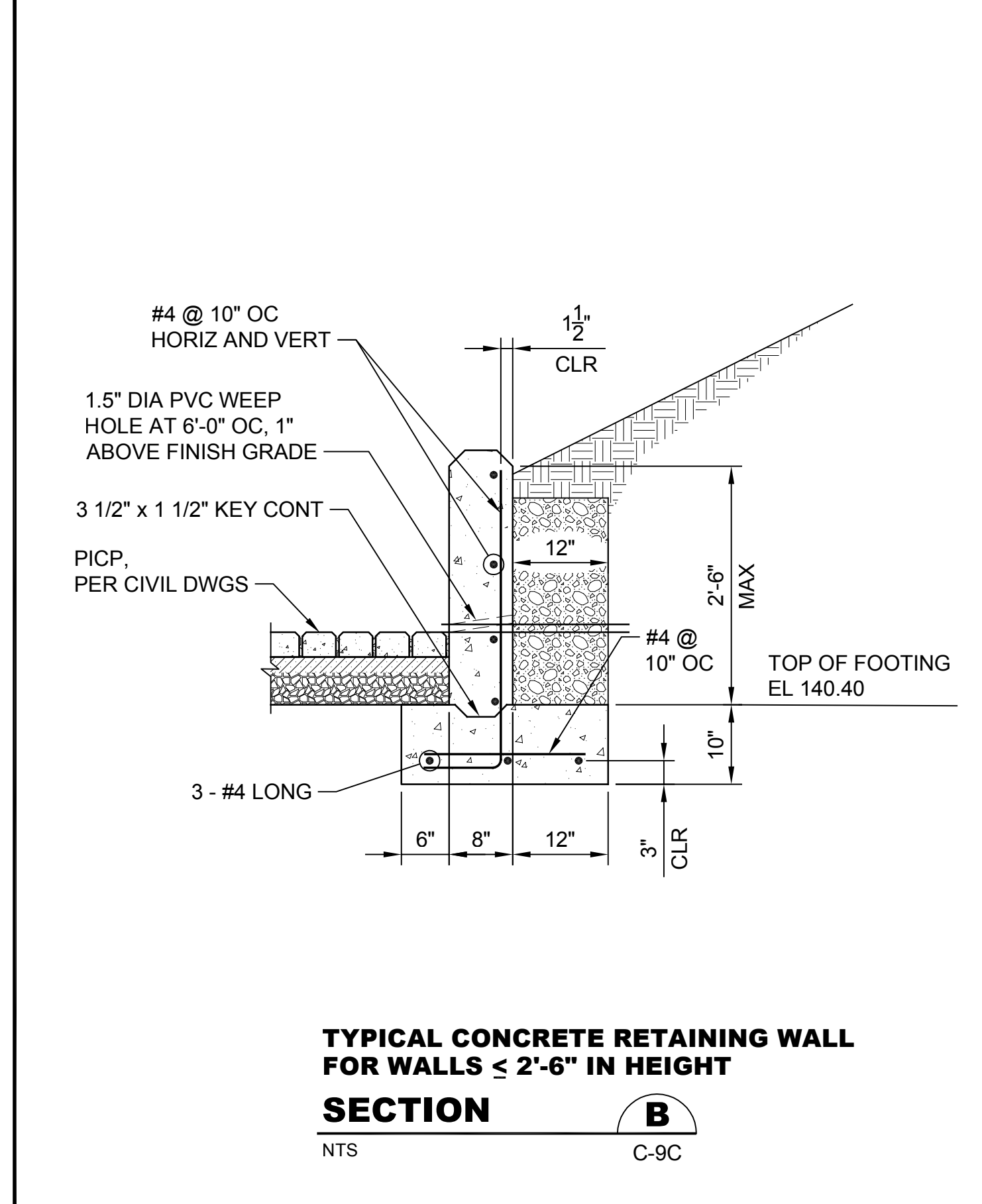
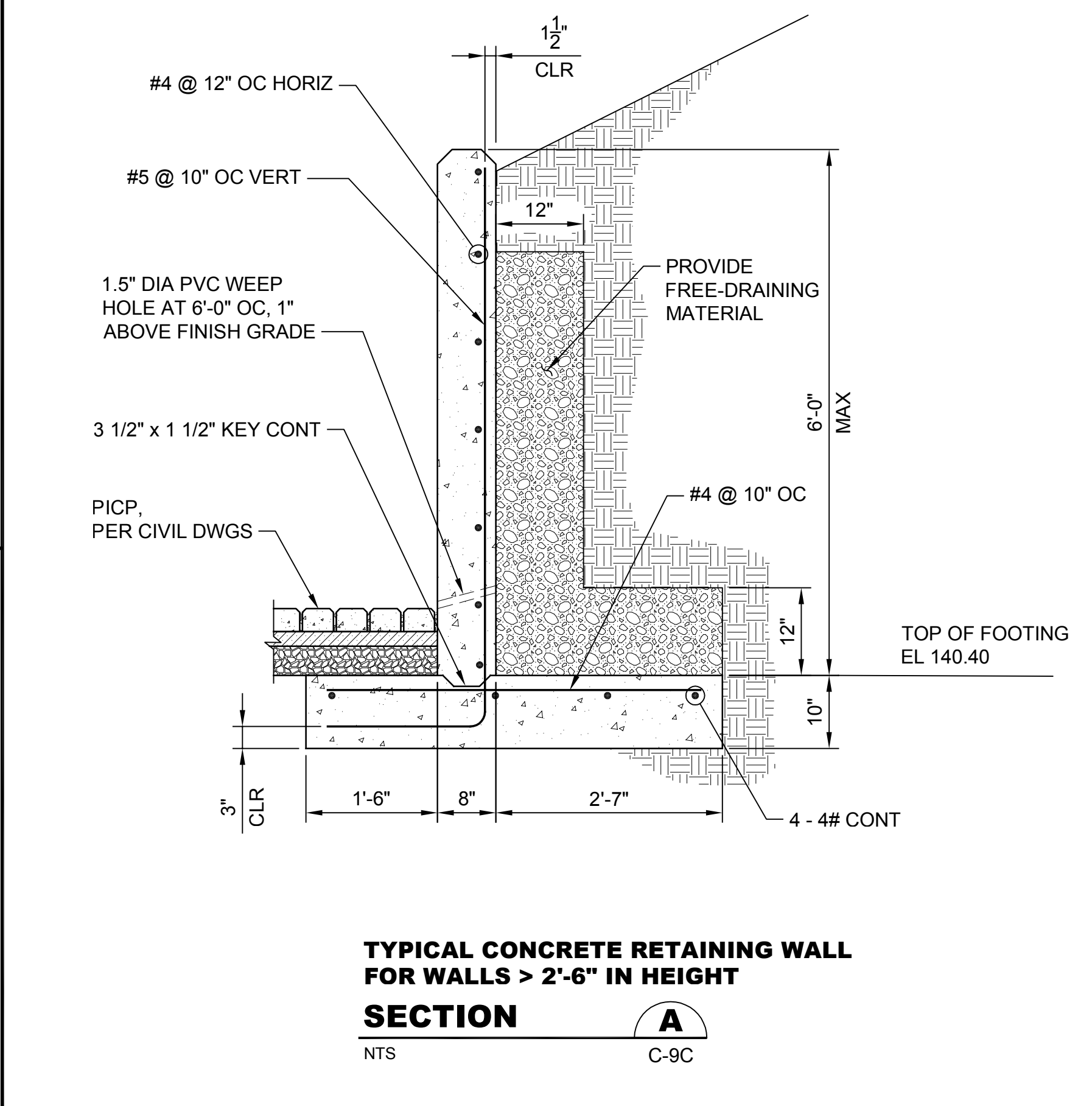
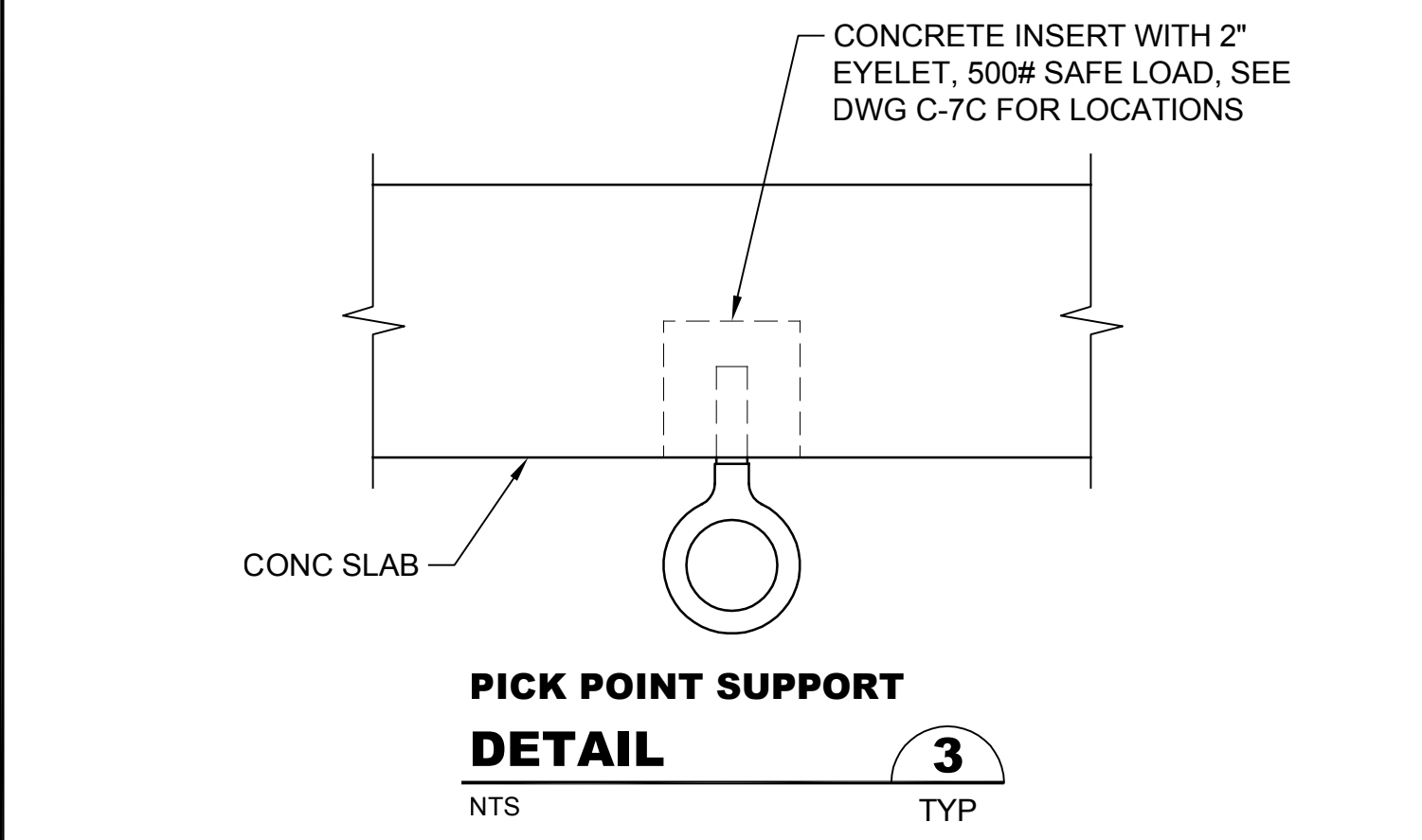
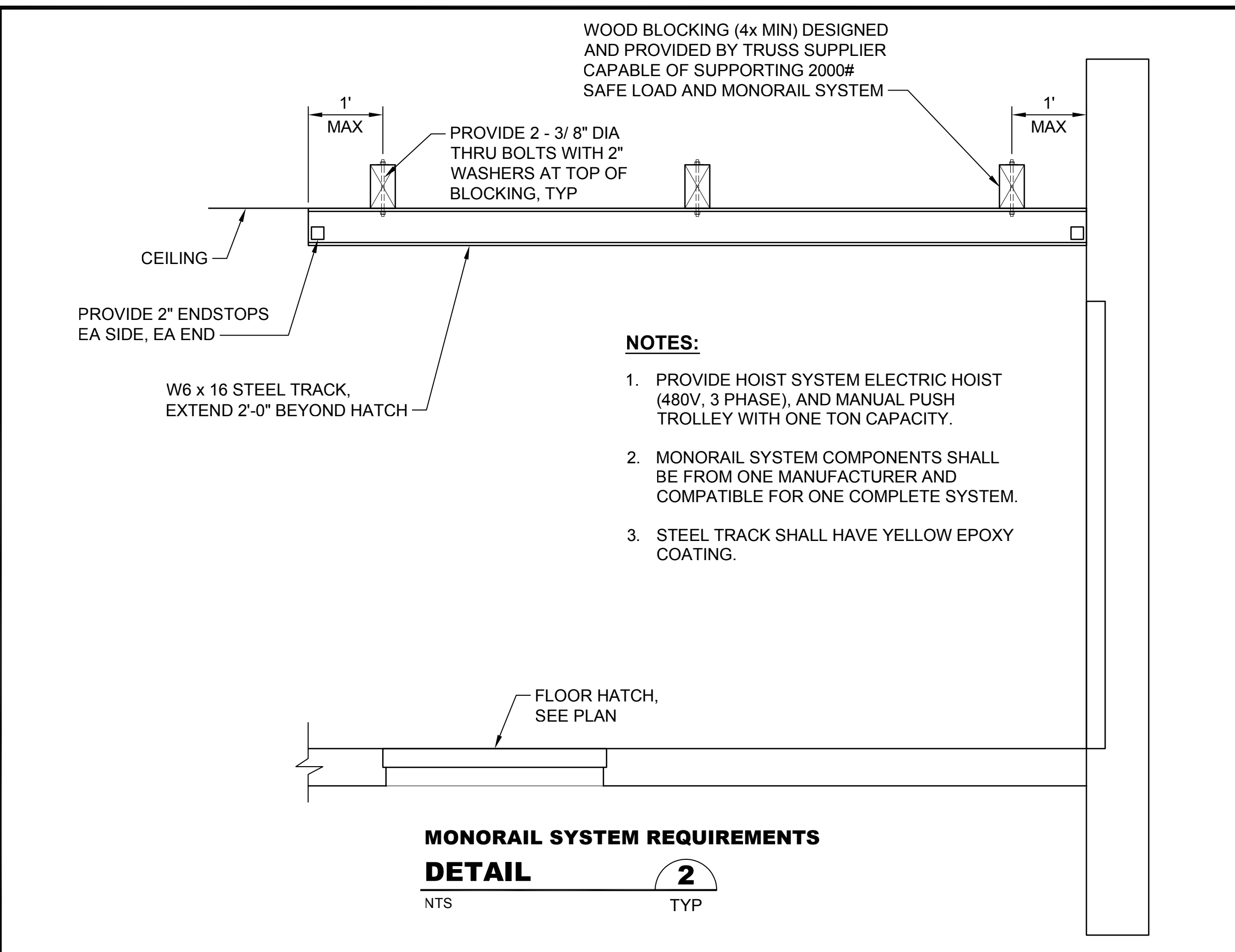
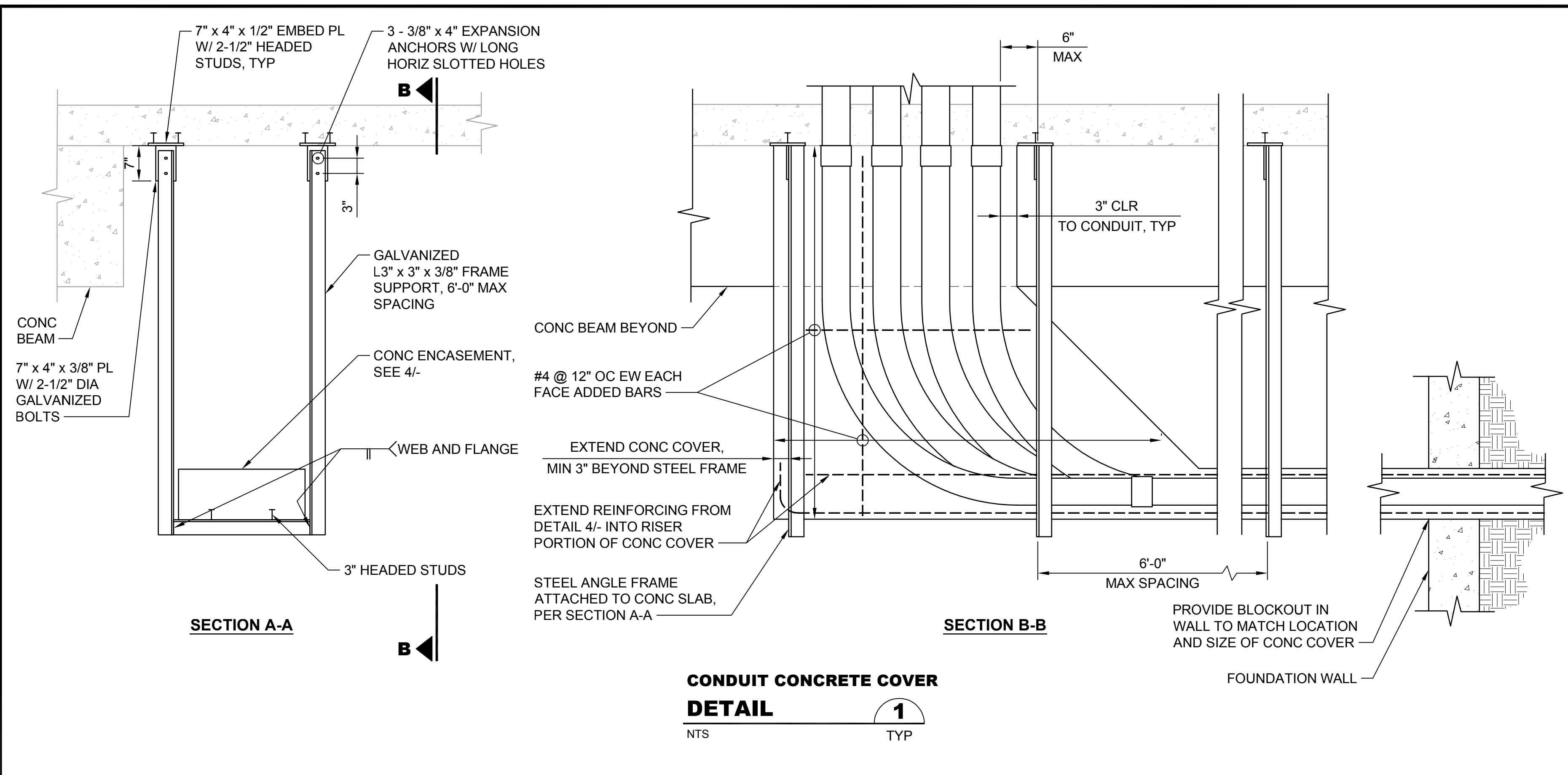

**Call 48 Hours Before You Dig**  
1-800-424-5555  
UNDERGROUND SERVICE



No.	Revision	Date	By	App'd
	ISSUED FOR BID	01-2023	TF	RAD



**BHC Consultants, LLC**  
1601 Fifth Avenue, Suite 500  
Seattle, Washington 98101  
206.505.3400  
206.505.3406 (fax)  
www.bhcconsultants.com

Designed: K. Dahl, P.E., S.E.  
Drawn: J. Lira  
Checked: T. Fisher, P.E.

Scale:  
NTS  
One Inch at Full Scale  
If Not One Inch Scale Accordingly



**Kitsap County Public Works**  
614 Division Street, MS 26  
Port Orchard, WA 98366

**SILVERDALE CONVEYANCE SYSTEM AND PUMP STATION 4 UPGRADES SCHEDULE C**

**TYPICAL DETAILS**

Drawing: **S-19C**  
Sheet: **77** of **117**  
File: P21-10530\_S-19C  
Date: January 2023

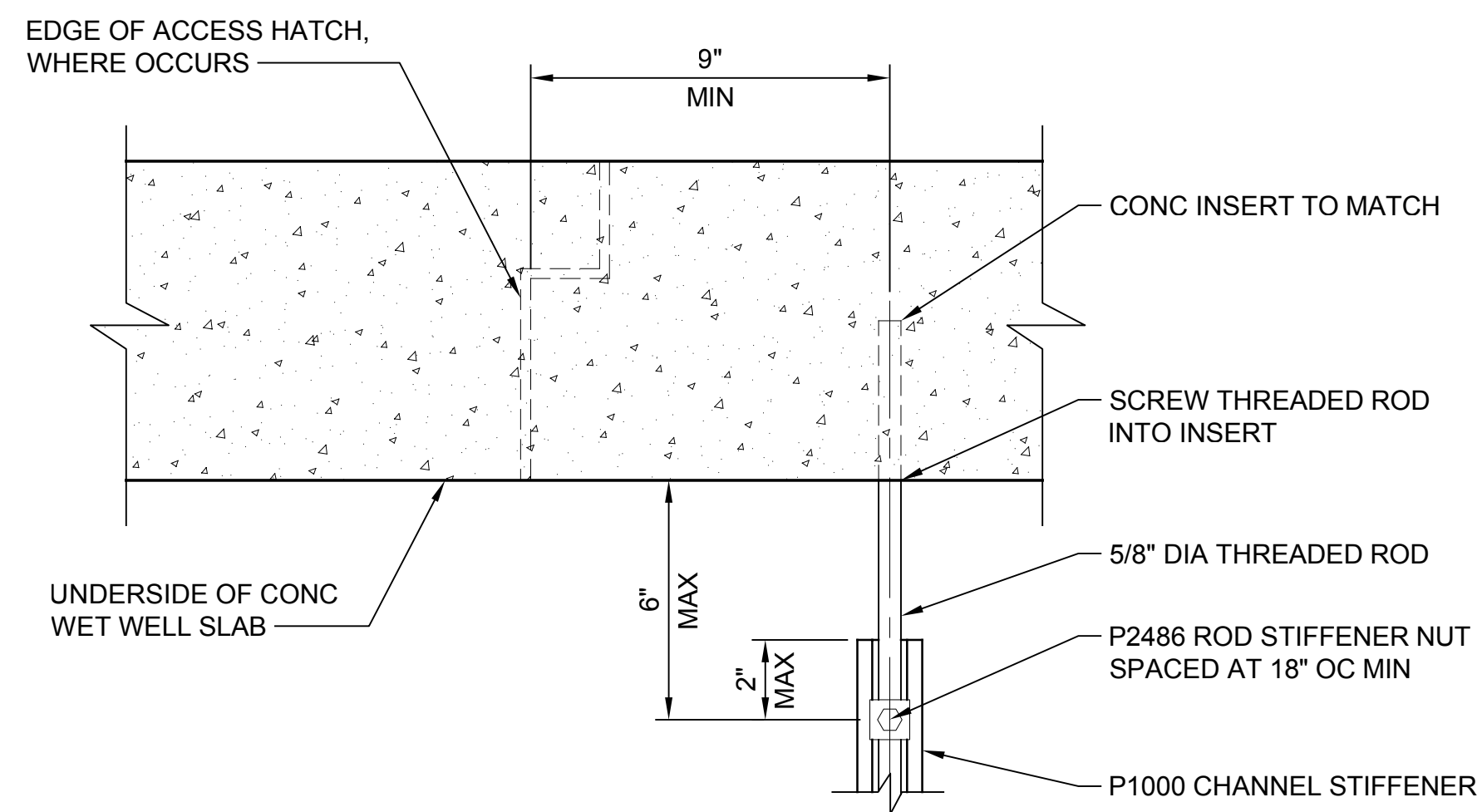

**BRACE TO HORIZONTAL HSS PUMP GUIDE RAIL SUPPORT**

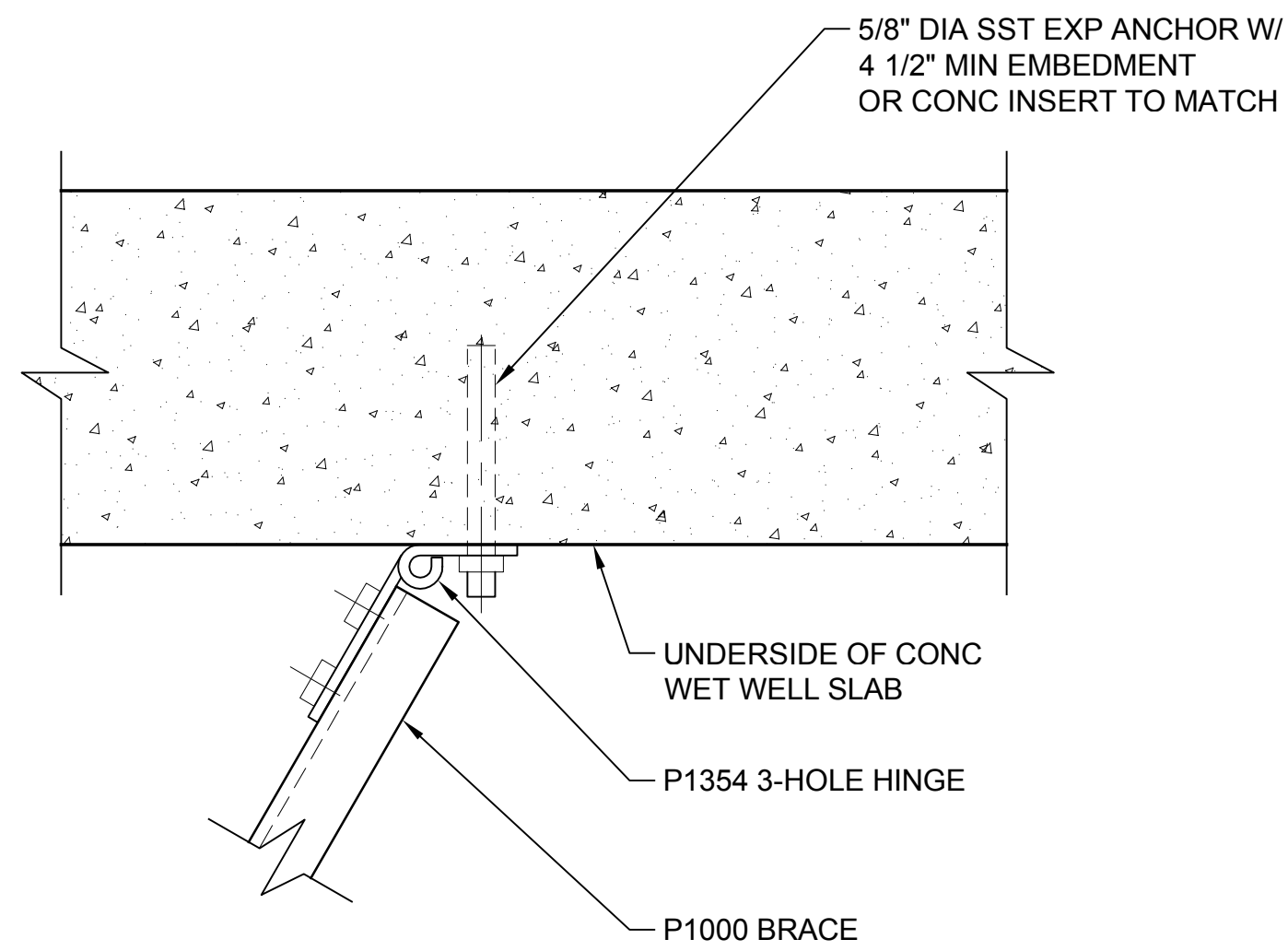

**LATERAL BRACE TO UNDERSIDE OF WET WELL SLAB**

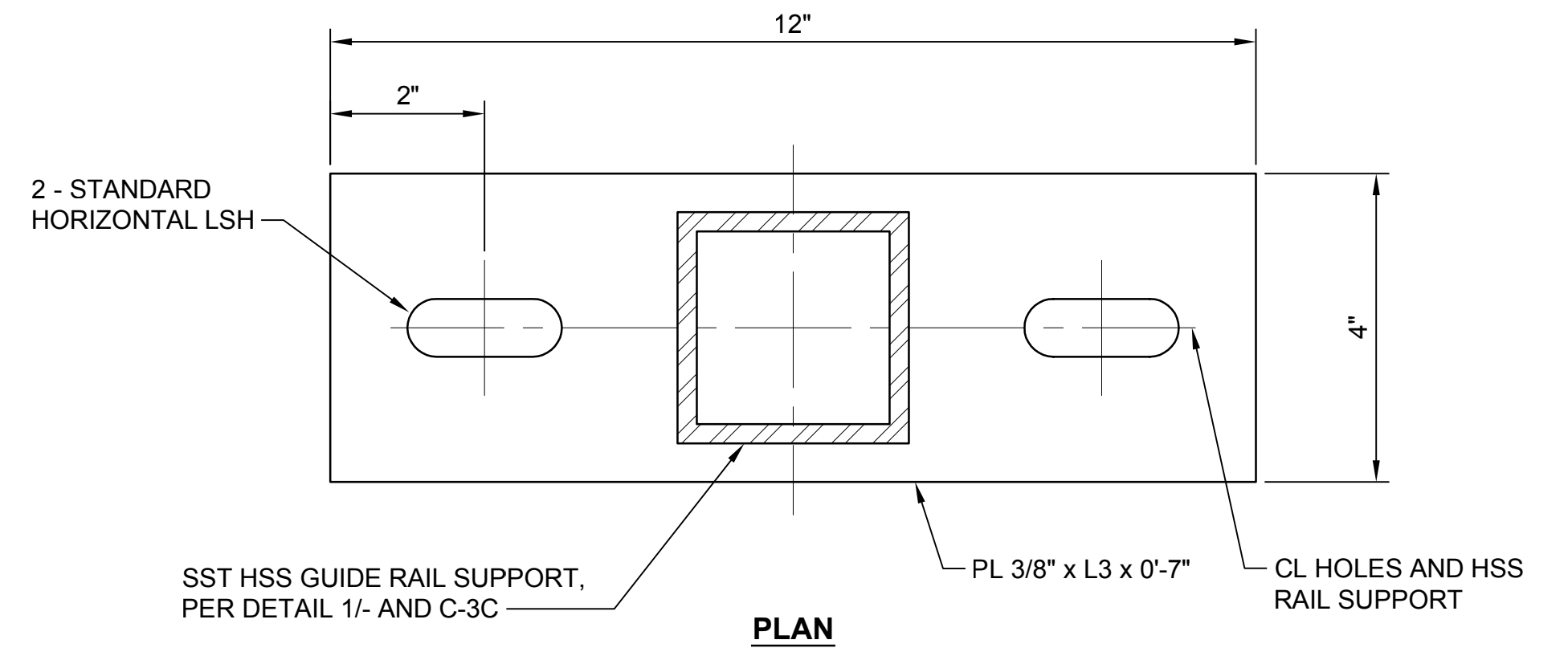

**PLAN**

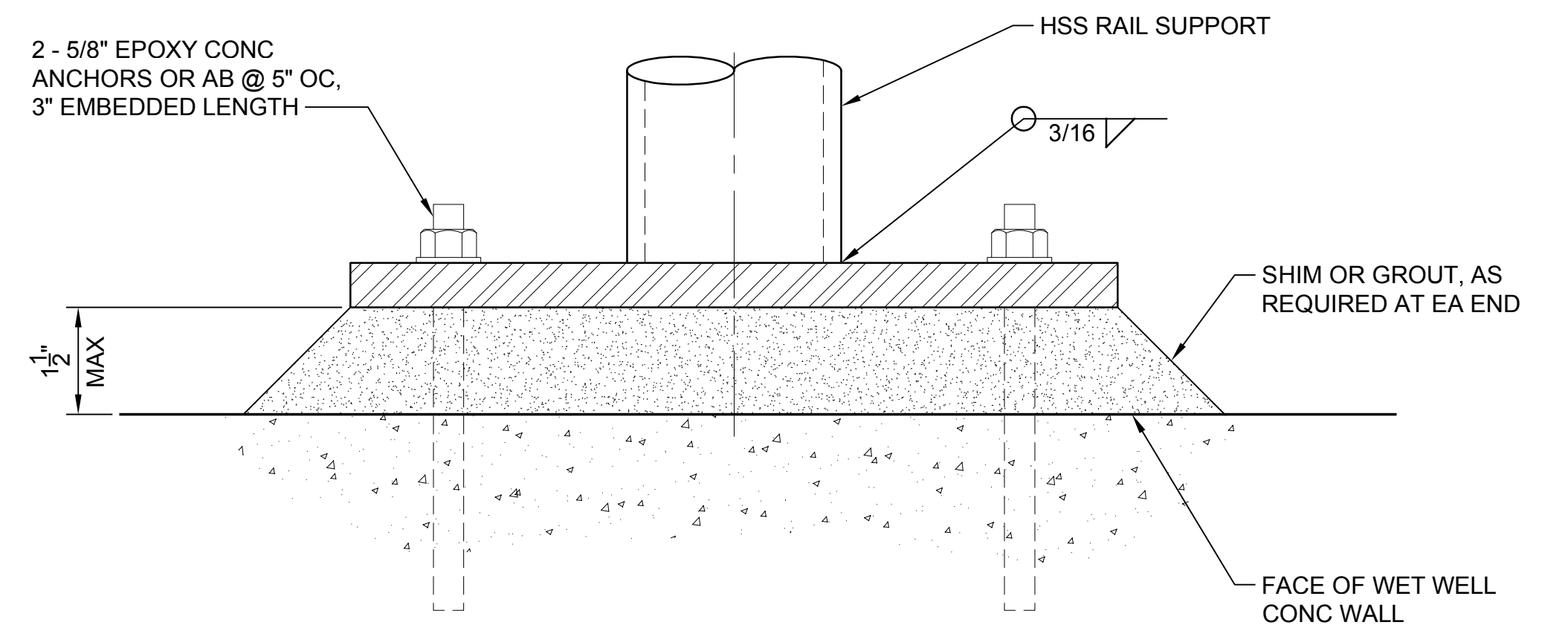

**ELEVATION**

**PUMP GUIDE RAIL LATERAL SUPPORTS CONNECTION TO WET WELL WALLS**

**DETAIL 2**  
NTS TYP

**Call 48 Hours Before You Dig**

**1-800-424-5555**  
UNDERGROUND SERVICE

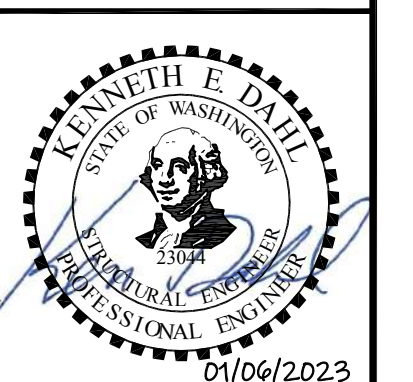

**NOTES:**

1. ALL STRUTS AND CONNECTIONS PREFACED WITH "P" SHALL BE UNISTRUT (R) OR APPROVED EQUAL.
2. ALL STRUTS, RODS, AND CONNECTION HARDWARE TO BE STAINLESS STEEL TYPE 304A.

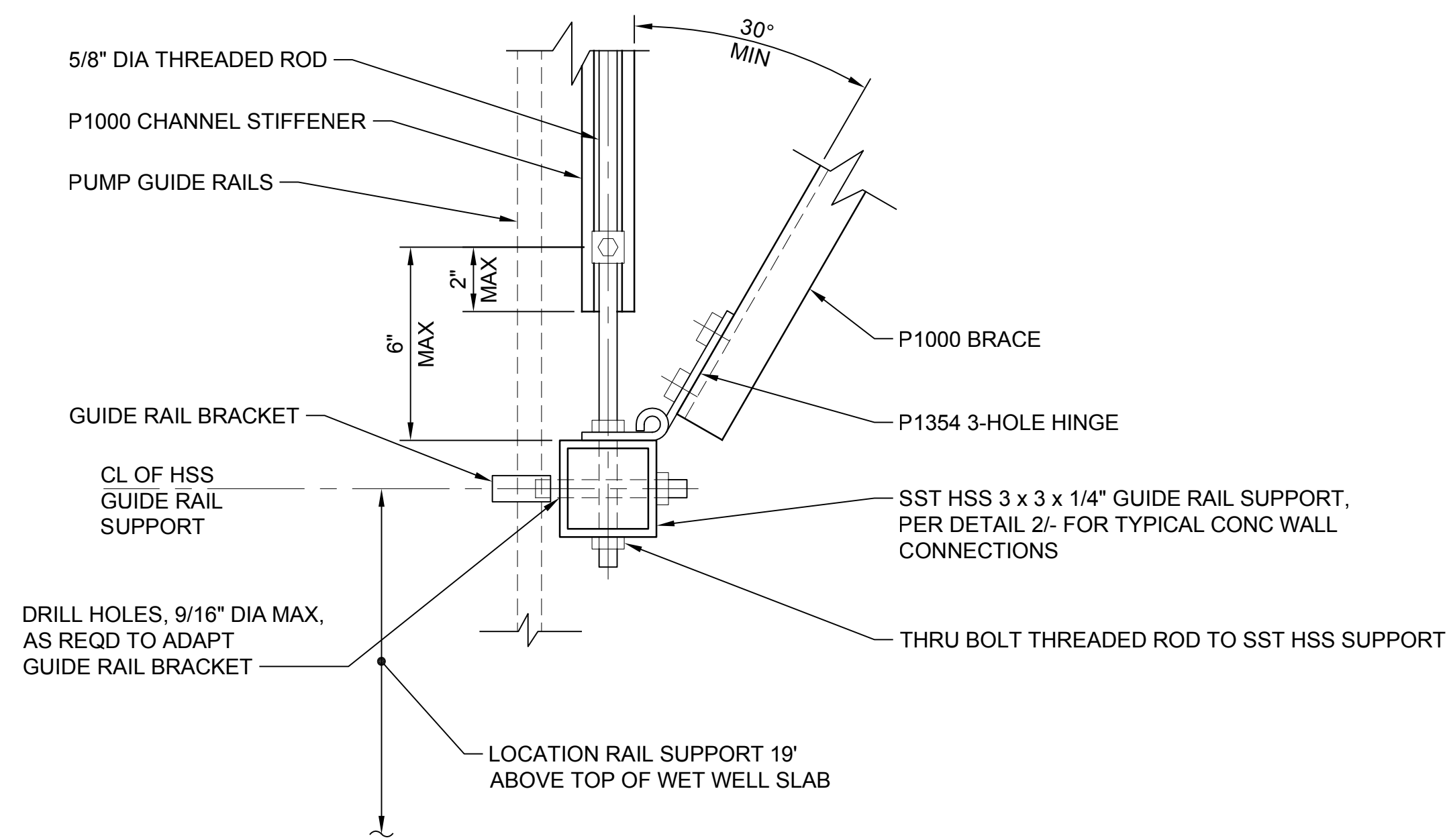

**BRACE TO HORIZONTAL HSS PUMP GUIDE RAIL SUPPORT**

**PUMP GUIDE RAIL LATERAL SUPPORT BRACE CONNECTIONS**

**DETAIL 1**  
NTS TYP



**BHC Consultants, LLC**  
1601 Fifth Avenue, Suite 500  
Seattle, Washington 98101  
206.505.3400  
206.505.3406 (fax)  
www.bhcconsultants.com

Designed: K. Dahl, P.E., S.E.  
Drawn: A. Bradley  
Checked: T. Fisher, P.E.

Scale:  
NTS  
One Inch at Full Scale  
If Not One Inch Scale Accordingly



**Kitsap County Public Works**  
614 Division Street, MS 26  
Port Orchard, WA 98366

**SILVERDALE CONVEYANCE SYSTEM AND PUMP STATION 4 UPGRADES SCHEDULE C**

**PUMP GUIDE RAIL LATERAL SUPPORT CONNECTIONS**

Drawing: **S-20C**  
Sheet: **78** of **117**  
File: P21-10530\_S-20C  
Date: January 2023

No.	Revision	Date	By	App'd
	ISSUED FOR BID	01-2023	TF	RAD







**GENERAL ABBREVIATIONS**

BTUH BRITISH THERMAL UNITS PER HOUR  
 (E) EXISTING  
 F FAHRENHEIT  
 FEV FUEL EMERGENCY VENT  
 FOR FUEL OIL RETURN  
 FOS FUEL OIL SUPPLY  
 FV FUEL NORMAL VENT  
 HP HORSE POWER; HEAT PUMP  
 HZ HERTZ  
 IBC INTERNATIONAL BUILDING CODE  
 IFC INTERNATIONAL FIRE CODE  
 IMC INTERNATIONAL MECHANICAL CODE  
 IN INCH  
 KW KILOWATT  
 LBS POUNDS  
 MCA MINIMUM CIRCUIT AMPACITY  
 MECH MECHANICAL; MECHANICAL CONTRACTOR  
 MOCP MAXIMUM OVER CURRENT PROTECTION  
 N NORTH  
 NTS NOT TO SCALE  
 PH PHASE  
 QTY QUANTITY  
 REFER REFRIGERANT  
 TYP TYPICAL  
 UBC UNIFORM BUILDING CODE  
 V VOLT  
 W WIDE(DIM); WATT  
 W/ WITH

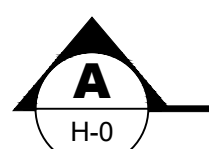
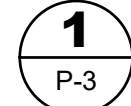

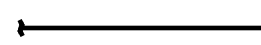
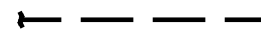

**HVAC ABBREVIATIONS**

BD BACK DRAFT DAMPER  
 BHP BRAKE HORSEPOWER  
 CFM CUBIC FEET PER MINUTE  
 COP COEFFICIENT OF PERFORMANCE  
 CU CONDENSING UNIT  
 EF EXHAUST FAN  
 EER ENERGY EFFICIENCY RATIO  
 OSA OUTSIDE AIR  
 UH UNIT HEATER  
 WSEC WASHINGTON STATE ENERGY CODE, COMMERCIAL PROVISIONS

**GENERAL LEGEND**

 **NORTH** NORTH ARROW  
 1/H-0 DETAIL/DRAWING REFERENCE  
 SECTION REFERENCE  
 DETAIL REFERENCE  
 CONSTRUCTION NOTE  
 REVISION SYMBOL  
 POINT OF CONNECTION  
 BOLD LINE WEIGHT INDICATES NEW WORK  
 BOLD DASHED LINE WEIGHT INDICATES NEW WORK BELOW SLAB  
 LIGHT LINE WEIGHT INDICATES EXISTING WORK

**HVAC LEGEND**

 THERMOSTAT  
 TIMER SWITCH  
 EQUIPMENT TAG  
 AIRFLOW SWITCH  
 WALL SWITCH

**GENERAL CONSTRUCTION NOTES**

1. PLANS ARE DIAGRAMMATIC AND DO NOT SHOW ALL SPECIALTIES AND EQUIPMENT.
2. FIELD VERIFY EXACT LOCATIONS OF EQUIPMENT PRIOR TO COMMENCING WORK.
3. MECHANICAL DRAWINGS SHOW DISCONNECT AND RECONNECT POINTS AT THE PROJECT'S BOUNDARIES. AN ATTEMPT WAS MADE TO SHOW MAJOR MECHANICAL UTILITY WORK WITHIN THE PROJECT'S BOUNDARIES.

**WASHINGTON ENERGY CODE NOTES**

1. PROVIDE POST CONSTRUCTION COMMISSIONING AND COMPLETION REQUIREMENTS IN ACCORDANCE WITH THE WASHINGTON STATE ENERGY CODE 2018 EDITION, SECTION C408 AND ACCORDING TO THE CONTRACT DOCUMENTS. SEE SPECIFICATION SECTIONS 23 05 00, 23 08 00 AND ALL OTHER APPLICABLE SPECIFICATION SECTIONS.
2. BALANCE ALL HVAC SYSTEMS IN ACCORDANCE WITH THE WASHINGTON STATE ENERGY CODE 2018 EDITION, GENERALLY ACCEPTED ENGINEERING STANDARDS AND IN ACCORDANCE WITH THE CONTRACT DOCUMENTS. SEE SPECIFICATION SECTION 23 05 93 AND ALL OTHER APPLICABLE SPECIFICATION SECTIONS.
3. PROVIDE CONTROLS IN ACCORDANCE WITH THE WASHINGTON STATE ENERGY CODE 2018 EDITION, INCLUDING SECTION FOR HVAC CONTROL, C403.2.5 FOR VENTILATION, C403.2.6 FOR ENERGY RECOVERY AND IN ACCORDANCE WITH THE CONTRACT DOCUMENTS. SEE TEMPERATURE CONTROL SPECIFICATION SECTIONS AND ALL OTHER APPLICABLE SPECIFICATION SECTIONS.
4. ALL MECHANICAL EQUIPMENT SHALL BE LISTED AND APPROVED BY A TESTING AGENCY.

Path: C:\Users\kenh\AppData\Local\Temp\AcPublish\_25 Filename: P21-10530-PS4\_H-OC Plot date: Jan 08, 2023 07:52:48am CAD User: kenh. Xref Filename: [X21-10530-PS4\_TB-Sub.dwg]

**Call 48 Hours Before You Dig**  
  
**1-800-424-5555**  
 UNDERGROUND SERVICE



No.	Revision	Date	By	App'd

**bhc**  
 CONSULTANTS  
 BHC Consultants, LLC  
 1801 Fifth Avenue, Suite 500  
 Seattle, Washington 98101  
 206.505.3400  
 206.505.3406 (fax)  
 www.bhcconsultants.com

**fsi**  
 ENGINEERS  
 Seattle // Spokane // Baltimore

Designed: ELL  
 Drawn: KH  
 Checked: JOJ

Scale:  
 As Shown  
 One Inch At Full Scale  
 If Not One Inch Scale Accordingly

 **Kitsap County Public Works**  
 614 Division Street, MS 26  
 Port Orchard, WA 98366

**SILVERDALE CONVEYANCE SYSTEM AND PUMP STATION 4 UPGRADES**  
 SCHEDULE C  
**CONTROL BUILDING**  
**HVAC LEGEND, ABBREVIATIONS AND GENERAL NOTES**

Drawing: **H-0C**  
 Sheet: **79** Of **117**  
 File: P21-10530-PS4\_H-OC  
 Date: January 2023

### SPLIT SYSTEM UNIT SCHEDULE

CALLOUT		LOCATION	AREA SERVED	UNIT CONFIGURATION	RATED UNIT EFFICIENCY [2]		COOLING [3]			HEATING	REFER TYPE	OPERATING WEIGHT (LBS)	ELECTRICAL					BASIS OF DESIGN		NOTES
TYPE	MARK				SEER	EER	NOMINAL CAPACITY (TONS) [4]	TOTAL COOLING (BTUH)	SENSIBLE COOLING (MBH)	CAPACITY @ OUTDOOR 17°F (MBH)			V	HZ	Ø	MOC	MCA	MANUFACTURER	MODEL	
HP	1	INSIDE	ELECTRICAL ROOM	CEILING MOUNT	21.0	11.6	3.5	42,000	33.2	30.8	R410A	56	208/230	60	1	-	2	mitsubishi	PLA-A42	[5]
CU	1	OUTSIDE		PAD MOUNT	R410A	214	208/230	60	1	31	25	mitsubishi	PUZ-A42	[1]						

**SCHEDULE NOTES:**

- [1] AIR REMOTE - INDOOR DX UNIT PIPED TO AIR-COOLED REMOTE DC CONDENSER OUTSIDE.
- [2] MINIMUM EFFICIENCY AS SCHEDULED AND AS REQUIRED BY THE WASHINGTON STATE NON-RESIDENTIAL ENERGY CODE.
- [3] AT 85F OUTDOOR AIR DRYBULB TEMPERATURE.
- [4] NOMINAL TONNAGE INCLUDED FOR REFERENCE ONLY - DO NOT USE FOR FINAL SIZING OF EQUIPMENT.
- [5] ECONOMIZER EXCEPTION 11 PER 2018 WSEC.

### EXHAUST FAN SCHEDULE

CALLOUT		LOCATION	SERVICE	FAN								MAX SOUND LEVEL (DBA)	BASIS OF DESIGN		NOTES	
TYPE	MARK			CFM	DRIVE TYPE	E.S.P (IN WC) [1]	RPM	MOTOR			ELECTRICAL [2]		MANUFACTURER	MODEL		
							HP	ENCLOSURE	TYP	V	Ø					
EF	1	UPPER LEVEL	DRY WELL	975	DIRECT	0.375	1725	3/4	ODP	EC	115	1	45	GREENHECK	SQ-130-VG	[3]
EF	2	RESTROOM	RESTROOM	100	DIRECT	0.25	932	15(W)	-	ECM	115	1	43	GREENHECK	SP-100-VG	[3] [4]

**SCHEDULE NOTES:**

- [1] STATIC PRESSURE EXTERNAL TO FAN.
- [2] SINGLE POINT CONNECTION. UNIT PROVIDED WITH INTEGRAL DISCONNECT.
- [3] PROVIDE HANGING NEOPRENE VIBRATION ISOLATION, INSULATED HOUSING, PERMATECTOR FINISH, AND BACKDRAFT DAMPER.
- [4] PROVIDE WITH MOTION SENSOR WALL SWITCH.

### SUPPLY FAN SCHEDULE

CALLOUT		LOCATION	SERVICE	FAN								MAX SOUND LEVEL (DBA)	BASIS OF DESIGN		NOTES	
TYPE	MARK			CFM	DRIVE TYPE	E.S.P (IN WC) [1]	RPM	MOTOR			ELECTRICAL [2]		MANUFACTURER	MODEL		
							HP	ENCLOSURE	TYP	V	Ø					
SF	1	UPPER LEVEL	DRY WELL	1100	DIRECT	0.25	1500	3/4	ODP	EC	115	1	46	GREENHECK	SQ-140-VG	[3]

**SCHEDULE NOTES:**

- [1] STATIC PRESSURE EXTERNAL TO FAN.
- [2] SINGLE POINT CONNECTION. UNIT PROVIDED WITH INTEGRAL DISCONNECT.
- [3] PROVIDE HANGING NEOPRENE VIBRATION ISOLATION, INSULATED HOUSING AND PERMATECTOR FINISH, AND BACKDRAFT DAMPER.

### UNIT HEATER SCHEDULE

CALLOUT		LOCATION	SERVICE	FAN			ELECTRICAL		BASIS OF DESIGN		NOTES
TYPE	MARK			AIRFLOW (CFM)	CAPACITY (KW)	STAGES	V	Ø	MANUFACTURER	MODEL	
UH	1	MID LEVEL	DRY WELL	725	10	1	480	3	KING	KB SERIES	[1] [2] [3]
UH	2	RESTROOM	RESTROOM	75	.5	1	120	1	KING	PAW SERIES	[3] [4]

**SCHEDULE NOTES:**

- [1] PROVIDE WITH WALL MOUNTING BRACKET
- [2] PROVIDE WITH INTEGRAL DISCONNECT SWITCH
- [3] PROVIDE WITH WALL THERMOSTAT AND LOW VOLTAGE CONTROL KIT.
- [4] PROVIDE WITH STAINLESS STEEL COVER.

### AIR TERMINAL SCHEDULE

CALLOUT	AIR TERMINAL DESCRIPTION	AIRFLOW CAPACITY LIMITS (CFM)		NOMINAL SIZE		NECK DIMENSIONS			MAX TSP DROP (IN. W.G.)	MATERIAL	OPD	FINISH	BASIS OF DESIGN		NOTES		
		MAXIMUM	MINIMUM	LENGTH	WIDTH	FOR RECTANGULAR		MANUFACTURER					MODEL				
						LENGTH	WIDTH							MAX NC			
EG-1	EGGRATE RETURN GRILLE	1200	801	24"	18"			18"	18"	10	0.02	ALUMINUM BORDER AND CORE	NO	#26 WHITE	TITUS	50F	[1]
SG-1	DUCT MOUNTED GRILLE	360	0	12"	8"			6"	10"	20	0.07	ALUMINUM	YES	#26 WHITE	TITUS	272FL	[1]

**SCHEDULE NOTES:**

- [1] PROVIDE DUCT MOUNTING.

**Call 48 Hours Before You Dig**

**1-800-424-5555**  
UNDERGROUND SERVICE



Path: I:\21021 Kitsap County PS 3 and 4 Upgrades\Working Drawings\PS4\_H-1C\_Plot.dwg; Jan 06, 2023-07:52:15 am CAD User: kenh. Xref Filename: I:\21-10530-PS4\_TB-Sub.dwg

No.	Revision	Date	By	App'd

**bhc**  
CONSULTANTS  
BHC Consultants, LLC  
1801 Fifth Avenue, Suite 500  
Seattle, Washington 98101  
206.505.3400  
206.505.3406 (fax)  
www.bhcconsultants.com

**fsi**  
ENGINEERS  
Seattle // Spokane // Baltimore

Designed: ELL  
Drawn: KH  
Checked: JOJ

Scale:  
As Shown  
One Inch At Full Scale  
If Not One Inch Scale Accordingly

**Kitsap County Public Works**  
614 Division Street, MS 26  
Port Orchard, WA 98366

**SILVERDALE CONVEYANCE SYSTEM AND PUMP STATION 4 UPGRADES SCHEDULE C**  
**CONTROL BUILDING**  
**HVAC SCHEDULES AND DETAILS**

Drawing: **H-1C**  
Sheet: **80** Of **117**  
File: P21-10530-PS4\_H-1C  
Date: January 2023



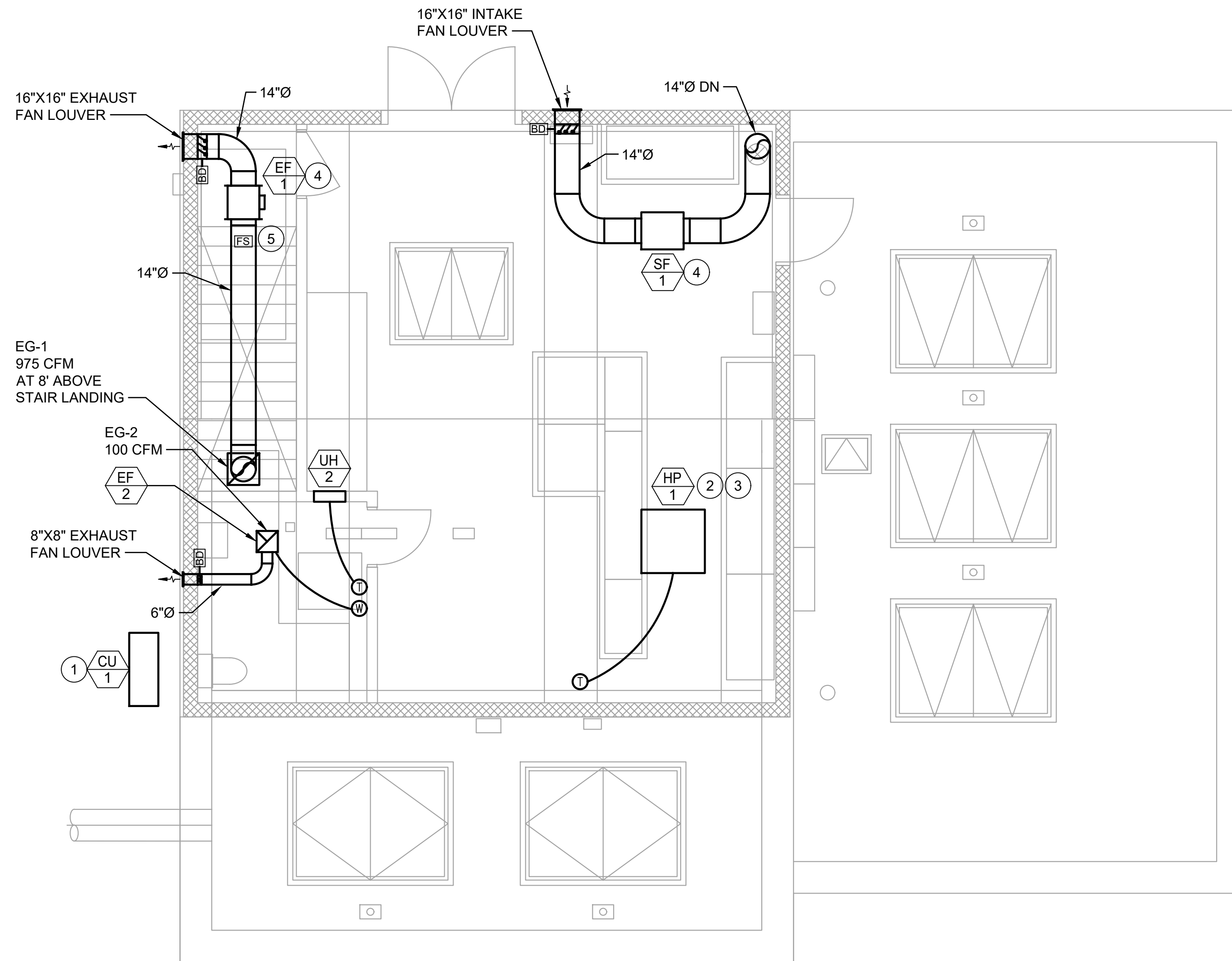

**PUMP STATION 4  
HVAC - ELECTRICAL ROOM  
PLAN**

SCALE: 1/4" = 1'-0" 1  
H-2C

**CONSTRUCTION NOTES:**

- ① MOUNT OUTDOOR UNIT ON EQUIPMENT PAD. REFER TO ARCHITECTURAL PLAN FOR EQUIPMENT PAD.
- ② MOUNT UNIT MINIMUM OF 82" AFF.
- ③ ROUTE RS/RL TO CONDENSING UNIT. PROVIDE CONDENSATE PIPING AND ROUTE TO OUTSIDE. PIPE SIZE PER MANUFACTURER.
- ④ RUN FAN CONTINUOUSLY.
- ⑤ INSTALL AIRFLOW SWITCH ON HORIZONTAL RUN OF DUCT PER MANUFACTURE'S RECOMMENDATION. REFER TO ELECTRICAL FOR WIRING ALARM SIGNAL.

Path: I:\21021 Kitsap County PS 3 and 4 Upgrades\Working Drawings\PS4\_H-2C\_Plot.dwg; Plot date: Jan 06, 2023, 07:52:57am; CAD User: kenh.  
 Xref Filename: I:\21-10530-PS4\_TB-Sub.dwg | X21-10530-PS4\_Ex-Bldg | X21-10530-PS4\_Prop-Bldg | X21-10530-PS4\_Prop-Mech | X21-10530-PS4\_Prop-Elec |

**Call 48 Hours  
Before You Dig**

**1-800-424-5555**  
UNDERGROUND SERVICE

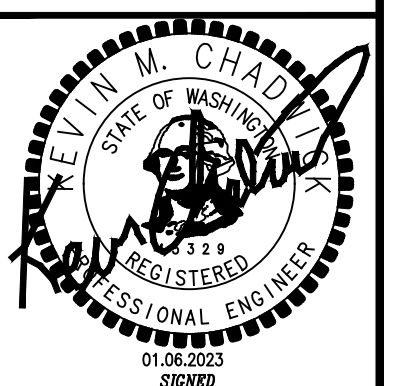

No.	Revision	Date	By	App'd

**bhc**  
CONSULTANTS

**BHC Consultants, LLC**  
1801 Fifth Avenue, Suite 500  
Seattle, Washington 98101

206.505.3400  
206.505.3406 (fax)  
www.bhcconsultants.com

**fsi**  
ENGINEERS

Seattle // Spokane // Baltimore

Designed: ELL  
Drawn: KH  
Checked: JOJ

Scale:  
1/4" = 1'-0"  
One Inch At Full Scale  
If Not One Inch Scale Accordingly

**Kitsap County Public Works**  
614 Division Street, MS 26  
Port Orchard, WA 98366

**SILVERDALE CONVEYANCE SYSTEM AND PUMP STATION 4 UPGRADES  
SCHEDULE C  
CONTROL BUILDING  
ELECTRICAL ROOM AND WET WELL PLAN HVAC**

Drawing: **H-2C**  
Sheet: **81** Of **117**  
File: P21-10530-PS4\_H-2C  
Date: January 2023

Path: I:\21021 Kitsap County PS 3 and 4 Upgrades\Working Drawings\PS4\_H-3C\_Plot.dwg; Plot date: Jan 06, 2023, 07:53:03am; CAD User: kenh.  
 Xref Filename: I:\21-10530-PS4\_TB-Sub.dwg | X21-10530-PS4\_Ex-Bldg | X21-10530-PS4\_Prop-Bldg | X21-10530-PS4\_Prop-Mech | X21-10530-PS4\_Prop-Elec |

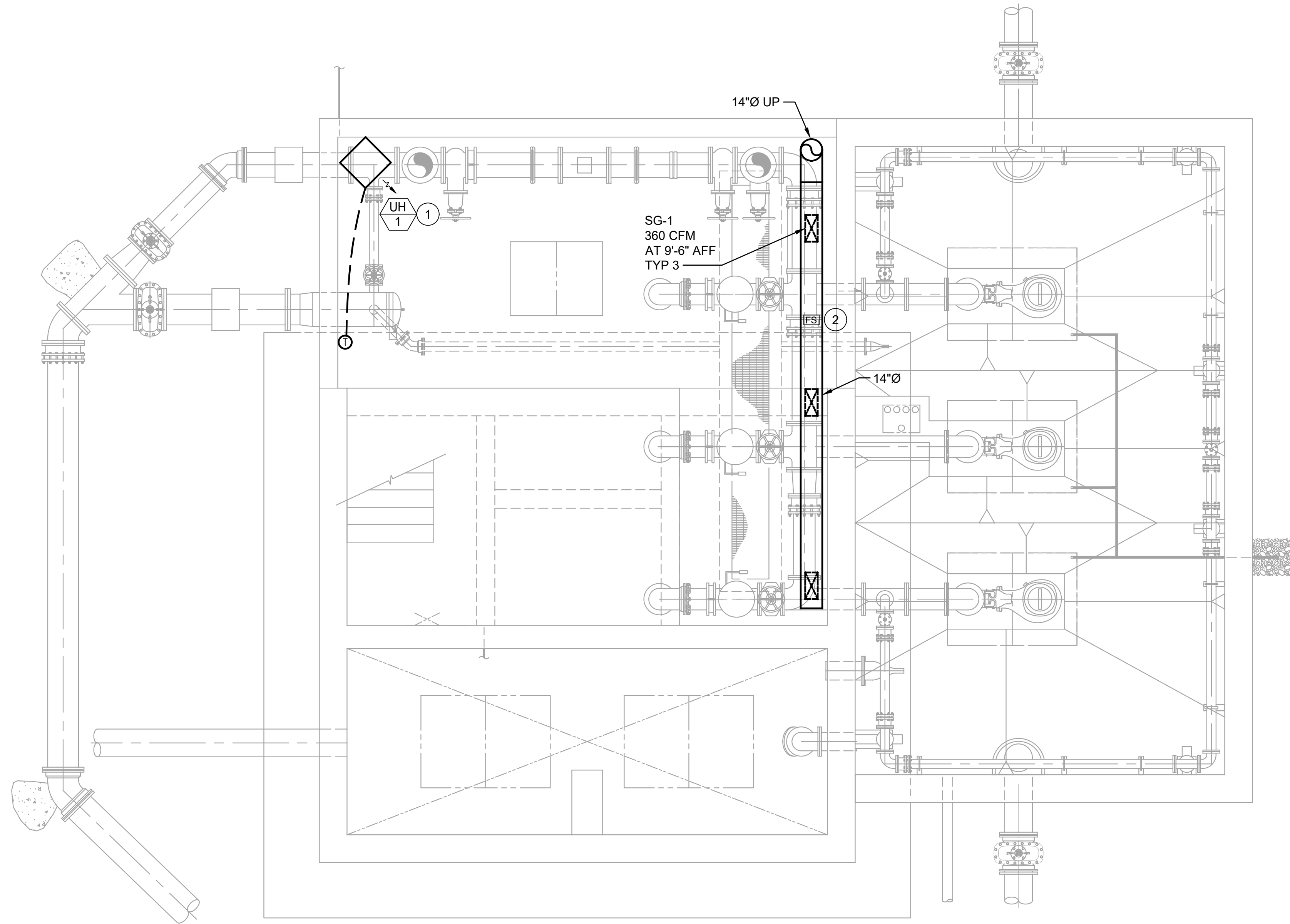

**CONSTRUCTION NOTES:**

- ① MOUNT UNIT AT 8' AFF.
- ② INSTALL AIRFLOW SWITCH ON HORIZONTAL RUN OF DUCT PER MANUFACTURER'S RECOMMENDATION. REFER TO ELECTRICAL FOR WIRING ALARM SIGNAL.

**PUMP STATION 4  
HVAC - MID LEVEL  
PLAN**

SCALE: 1/4" = 1'-0"

1  
H-3C

**Call 48 Hours  
Before You Dig**

**1-800-424-5555**  
UNDERGROUND SERVICE

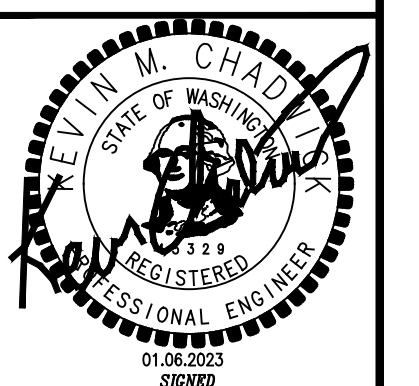

No.	Revision	Date	By	App'd

**bhc**  
CONSULTANTS

**BHC Consultants, LLC**  
1801 Fifth Avenue, Suite 500  
Seattle, Washington 98101

206.505.3400  
206.505.3406 (fax)  
www.bhcconsultants.com

**fsi**  
ENGINEERS

Seattle // Spokane // Baltimore

Designed: ELL  
 Drawn: KH  
 Checked: JOJ

Scale:  
 1/4" = 1'-0"  
 One Inch At Full Scale  
 If Not One Inch Scale Accordingly

**Kitsap County Public Works**  
614 Division Street, MS 26  
Port Orchard, WA 98366

**SILVERDALE CONVEYANCE SYSTEM AND PUMP STATION 4 UPGRADES  
SCHEDULE C  
CONTROL BUILDING  
PIPING ROOM AND WET WELL PLAN - HVAC**

Drawing: **H-3C**  
 Sheet: **82** Of **117**  
 File: P21-10530-PS4\_H-3C  
 Date: January 2023

**PLUMBING LEGEND**

	DOMESTIC COLD WATER (CW)
	SOIL, WASTE (S,W)
	VENT (V)
	PIPING IDENTIFIER, SEE ABBREVIATIONS
	ELBOW DOWN
	ELBOW UP
	TEE
	TEE DN
	TEE UP
	REDUCER
	NORMALLY CLOSED BALL VALVE
	NORMALLY OPEN BALL VALVE

**PLUMBING ABBREVIATIONS**

CO	CLEAN OUT
CW	COLD WATER
DOM	DOMESTIC
FCO	FLOOR CLEAN OUT
FD	FLOOR DRAIN
GPM	GALLONS PER MINUTE
HB	HOSE BIBB
IPC	INTERNATIONAL PLUMBING CODE
NC	NORMALLY CLOSED
PRV	PRESSURE REDUCING VALVE
PSE	PUGET SOUND ENERGY
RPBA	REDUCED PRESSURE BACKFLOW ASSEMBLY
UPC	UNIFORM PLUMBING CODE
V	VENT
W	WASTE

**PLUMBING GENERAL NOTES**

1. PROVIDE COMPLETE SUPPORTS, SEISMIC AND RESTRAINTS FOR ALL PIPES AND EQUIPMENT PER SPECIFICATIONS, AS REQUIRED, AND AS SHOWN ON THE DRAWINGS.
2. REFER TO ARCHITECTURAL DRAWINGS FOR FIXTURE LOCATION AND ELEVATION.
3. PIPING PENETRATION THROUGH FIRE RATED WALLS OR FLOORS SHALL BE SLEEVED AND FIRE STOPPED WITH LISTED MATERIALS TO MAINTAIN RATING OF FLOOR OR WALL. INSULATED PIPING SHALL BE CONTINUOUSLY INSULATED THROUGH FLOOR OR WALL.
4. INSTALLATION SHALL BE COORDINATED WITH BUILDING STRUCTURE AND OTHER TRADES PRIOR FABRICATION AND INSTALLATION.
5. PROVIDE ISOLATION VALVE AT BRANCH SERVING 5 FIXTURES OR MORE.
6. ALL DOMESTIC HOT WATER PIPING TO FIXTURES SHALL BE DONE IN ACCORDANCE WITH 2018 WSEC INCLUDING SECTION C404.3.
7. ALL PIPING SERVING PLUMBING SYSTEMS SHALL BE INSULATED IN ACCORDANCE WITH 2018 WSEC TABLE C403.10.3

Path: I:\21021 Kitsap County PS 3 and 4 Upgrades\Working Drawings\IP Filename: P21-10530-PS4\_P-0C Plot date: Jan 06, 2023-07:53:06am CAD User: kenh.  
Xref Filename: I\X21-10530-PS4\_TB-Sub.dwg

**Call 48 Hours  
Before You Dig**  
1-800-424-5555  
UNDERGROUND SERVICE



No.	Revision	Date	By	App'd

**bhc**  
CONSULTANTS

**BHC Consultants, LLC**  
1801 Fifth Avenue, Suite 500  
Seattle, Washington 98101

206.505.3400  
206.505.3406 (fax)  
www.bhcconsultants.com

**fsi**  
ENGINEERS

Seattle // Spokane // Baltimore

Designed:	ELL
Drawn:	KH
Checked:	JOJ

Scale:	As Shown
	One Inch At Full Scale If Not One Inch Scale Accordingly

**Kitsap County Public Works**  
614 Division Street, MS 26  
Port Orchard, WA 98366

**SILVERDALE CONVEYANCE SYSTEM AND PUMP STATION 4 UPGRADES  
SCHEDULE C  
CONTROL BUILDING  
PLUMBING LEGEND, ABBREVIATIONS, AND GENERAL NOTES**

Drawing:	<b>P-0C</b>
Sheet:	<b>83</b> Of <b>117</b>
File:	P21-10530-PS4_P-0DC
Date:	January 2023

## PLUMBING FIXTURE SCHEDULE

MARK	FIXTURE DESCRIPTION	BRANCH PIPE SIZE - INCHES DIA.				ADDITIONAL COMPONENTS	BASIS OF DESIGN		REMARKS
		COLD WATER	HOT WATER	WASTE	VENT		MANUFACTURER	MODEL	
LAV-1	WALL-HUNG LAVATORY	1/2"	-	1 1/2"	1 1/4"	CARRIER: JAY R. SMITH FIG 0720 CHICAGO #420-ABCP W/ POP-UP DRAIN	KOHLER	#K-2005	ADA WITH PROTECTIVE SHIELD AND THERMOSTATIC MIXING VALVE COMPLIANCE WITH ASSE 1070
WC-1	FLOOR-MOUNTED WATER CLOSET	1"	-	4"	2"	SEAT: OLSONITE #95	KOHLER	#K-3575	ADA, OBC, B651 COMPLIANT.
HR-1	WALL MOUNTED HOSE RACK	-	-	-	-	HEAVY DUTY HOOK. 5.5" WIDE X 5' HIGH X 4 1/8" DEEP	MASTER-CARR	2614N11	
TP-1	TRAP PRIMER	1/2"	-	-	-	ELECTRONIC TRAP PRIMER, 120V/60	PPP	MPB-500	COORDINATE WITH ELECTRICIAN FOR POWER
FD-1	FLOOR DRAIN					ROUND NICKEL-BRONZE STRAINER, NO-HUB OUTLET AND TRAP PRIMER CONNECTION	JAY R. SMITH	2005Y	

## WATER HEATER SCHEDULE

CALLOUT		LOCATION	DEMAND (GPM)	SERVICE CONDITIONS		CAPACITY	ELECTRICAL					BASIS OF DESIGN		
TYPE	MARK			EWT (DEG F)	LWT (DEG F)		WATER TEMP RISE (DEG F)	INPUT KW	NO. OF STEPS	V	HZ	Ø	FLA	MANUFACTURER
TANKLESS	WH-1	RESTROOM	.3	50	119	79	3.6	1	120	60	1	30	BOSCH	TRONIC 3000-US3-2R

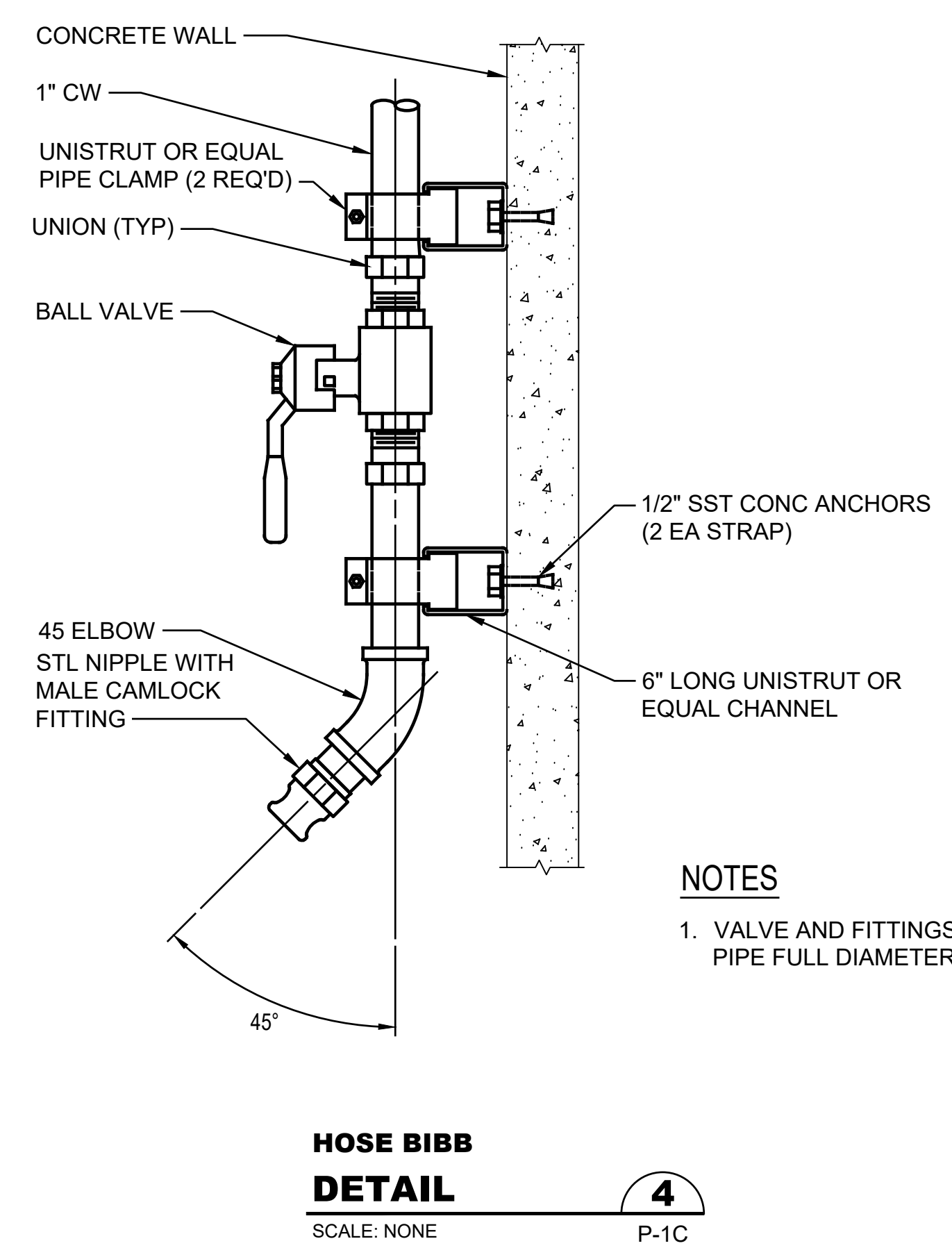
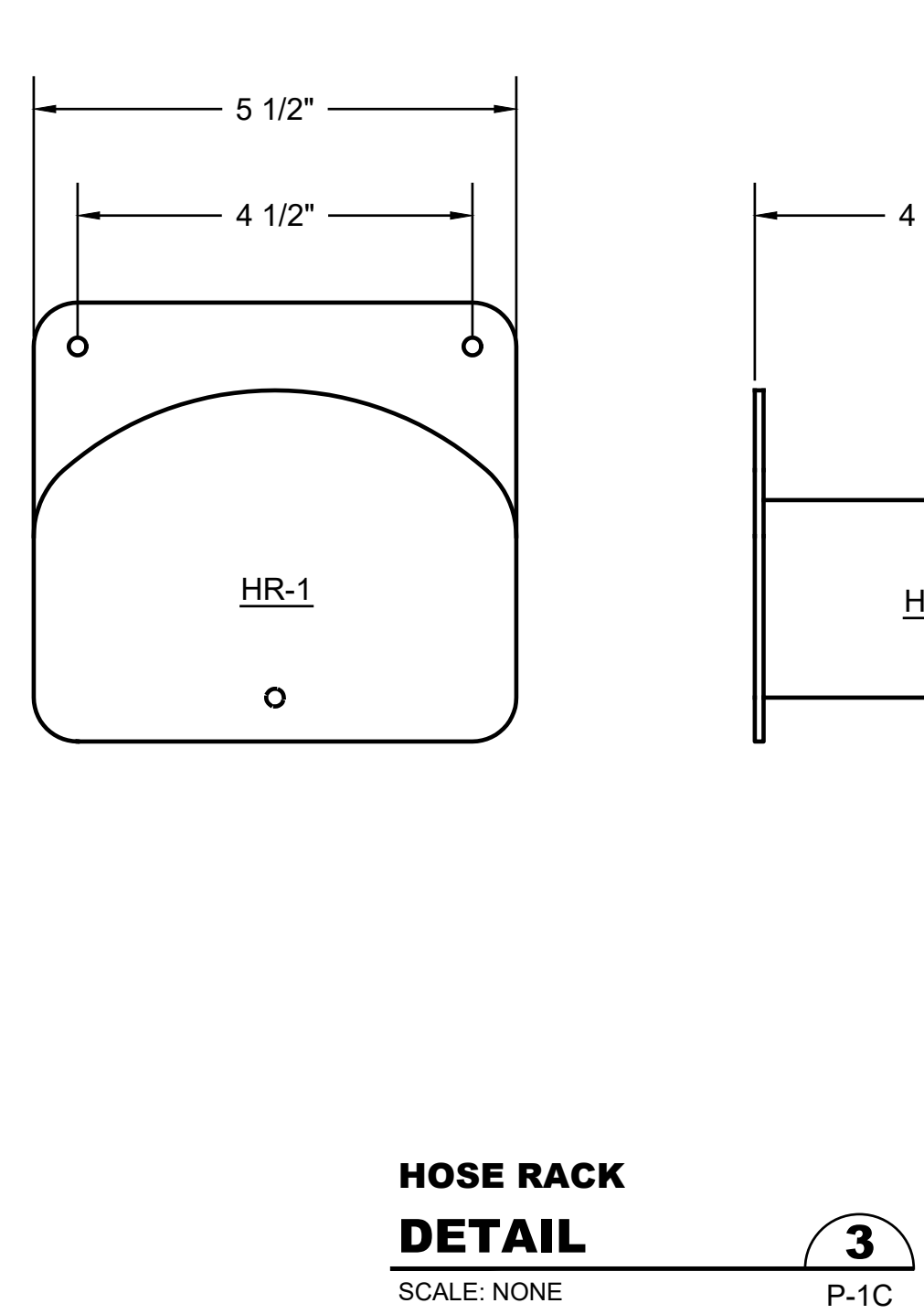
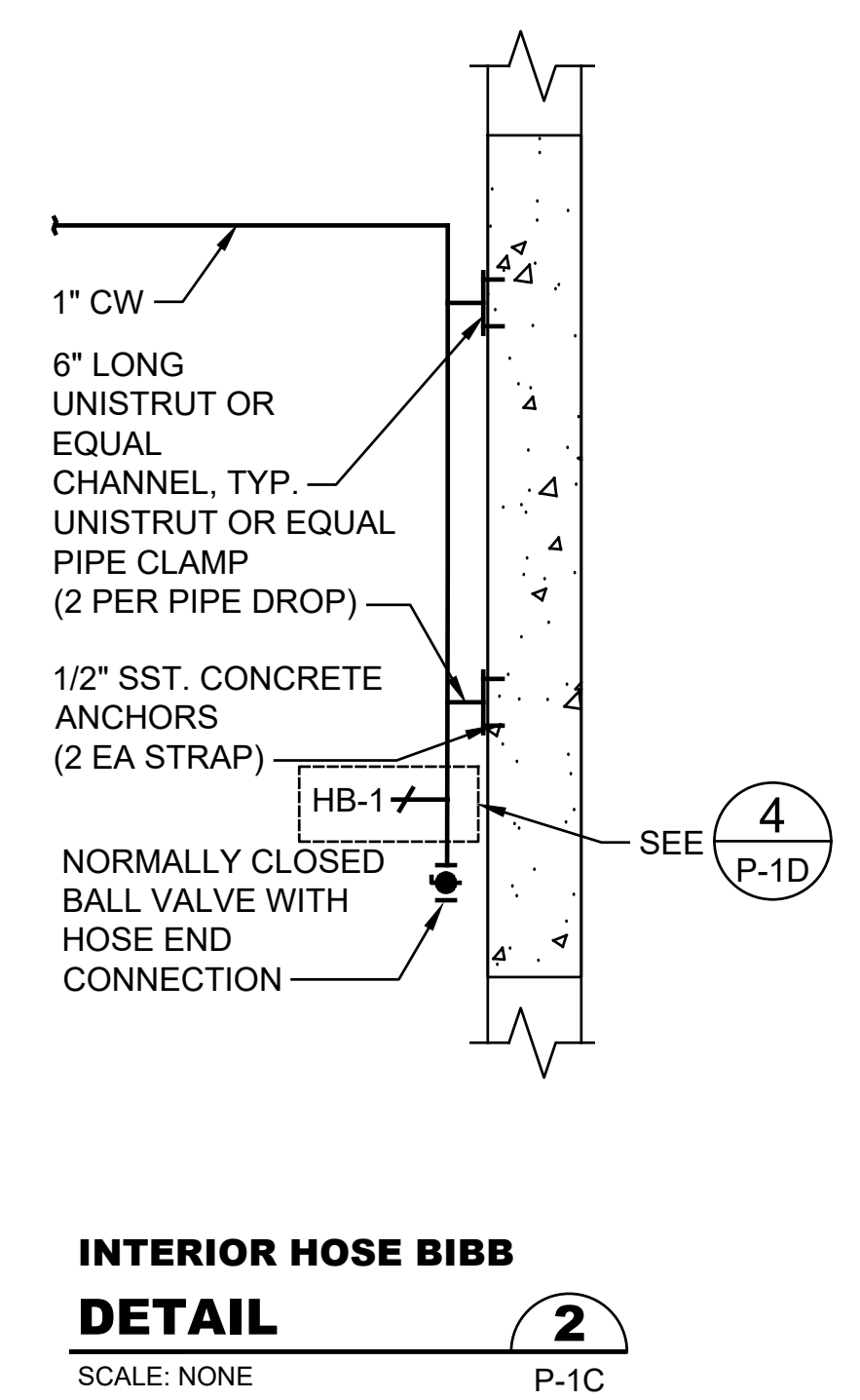
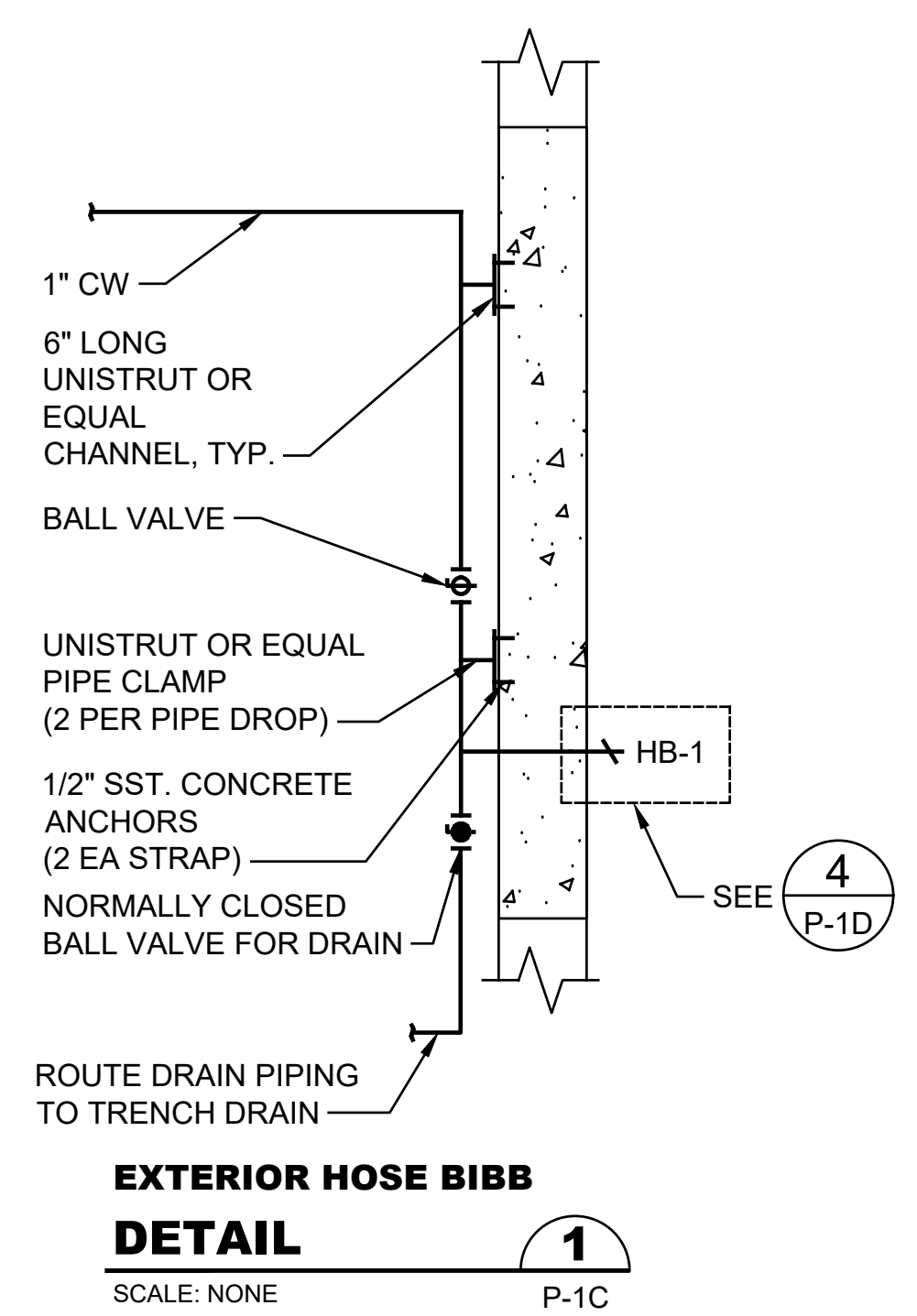

**NOTES**  
1. VALVE AND FITTINGS SIZED TO MATCH PIPE FULL DIAMETER

**Call 48 Hours Before You Dig**  
1-800-424-5555  
UNDERGROUND SERVICE



Path: I:\21021 Kitsap County PS 3 and 4 Upgrades\Working Drawings\P File\Name: P21-10530-PS4\_P-1C Plot date: Jan 06, 2023-07:53:09am CAD User: kenh. Xref File Name: I:\21-10530-PS4\_TB-Sub.dwg

No.	Revision	Date	By	App'd

**bhc**  
CONSULTANTS

BHC Consultants, LLC  
1801 Fifth Avenue, Suite 500  
Seattle, Washington 98101  
206.505.3400  
206.505.3406 (fax)  
www.bhcconsultants.com

**fsi**  
ENGINEERS

Seattle // Spokane // Baltimore

Designed: ELL	Scale: As Shown One Inch At Full Scale If Not One Inch Scale Accordingly
Drawn: KH	
Checked: JOJ	

**Kitsap County Public Works**

614 Division Street, MS 26  
Port Orchard, WA 98366

**SILVERDALE CONVEYANCE SYSTEM AND PUMP STATION 4 UPGRADES**  
SCHEDULE C  
**CONTROL BUILDING**  
**PLUMBING SCHEDULE AND DETAILS**

Drawing: <b>P-1C</b>
Sheet: <b>84</b> Of <b>117</b>
File: P21-10530-PS4_P-1C
Date: January 2023

Path: I:\21021 Kitsap County PS 3 and 4 Upgrades\Working Drawings\PS4\_P-2C\_Plot.dwg; Plot date: Jan 06, 2023, 07:53:15am CAD User: kenh.  
 Xref Filename: I:\21-10530-PS4\_TB-Sub.dwg | X21-10530-PS4\_Ext.Bldg | X21-10530-PS4\_Prop.Bldg | X21-10530-PS4\_Prop.Mech |

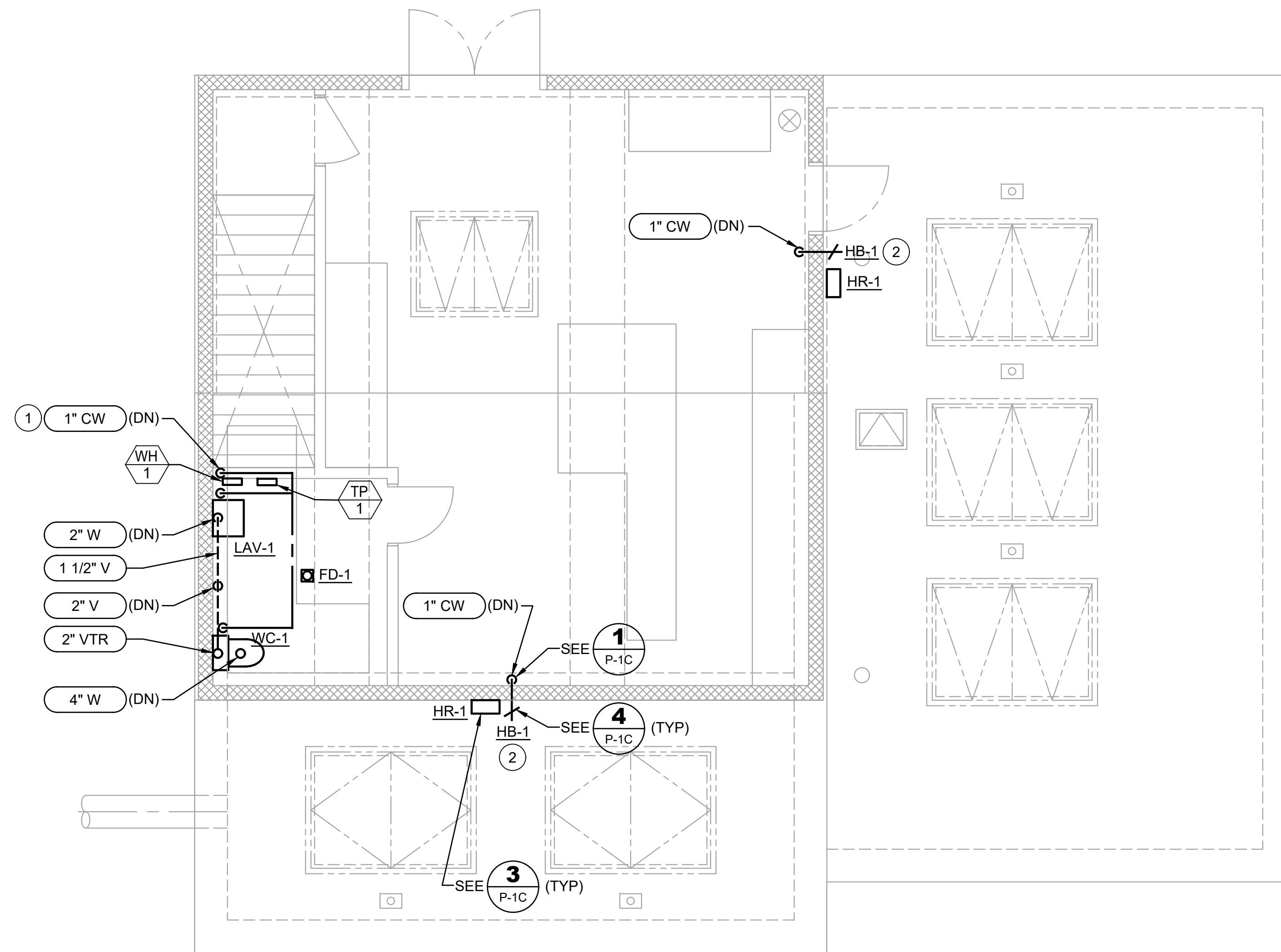

**PUMP STATION 4  
 PLUMBING - ELECTRICAL ROOM  
 PLAN**  
 SCALE: 1/4" = 1'-0" 1  
 P-2C

**NOTES:**

1. ALL BOLTED CONNECTIONS IN THE WET WELL SHALL BE CONSTRUCTED WITH DOUBLE 316L SST NUTS.
2. ALL BELL AND SPIGOT, MECHANICAL, AND PLAIN END JOINTS SHALL BE RESTRAINED.
3. COORDINATE HATCH LOCATION WITH PUMP MANUFACTURER AND GUIDE RAILS TO AVOID CONFLICTS. ALL ACCESS HATCHES SHALL HAVE A SAFETY GRATE BY HATCH MANUFACTURER UNLESS NOTED OTHERWISE. SAFETY GRATE SWING SHALL BE THE SAME AS THE HATCH DOOR.
4. WATER PIPING SHALL NOT BE ROUTED DIRECTLY ABOVE ELECTRICAL EQUIPMENT

**CONSTRUCTION NOTES:**

- 1 ROUTE PIPING INSIDE WALL AND ABOVE CEILING
- 2 MOUNT HB-1 3'-0" ABOVE GROUND.

**Call 48 Hours  
 Before You Dig**

**1-800-424-5555**  
 UNDERGROUND SERVICE



No.	Revision	Date	By	App'd

**bhc**  
 CONSULTANTS  
 BHC Consultants, LLC  
 1801 Fifth Avenue, Suite 500  
 Seattle, Washington 98101  
 206.505.3400  
 206.505.3406 (fax)  
 www.bhcconsultants.com

**fsi**  
 ENGINEERS  
 Seattle // Spokane // Baltimore

Designed: ELL  
 Drawn: KH  
 Checked: JOJ

Scale:  
 1/4" = 1'-0"  
 One Inch At Full Scale  
 If Not One Inch Scale Accordingly

**Kitsap County Public Works**  
 614 Division Street, MS 26  
 Port Orchard, WA 98366

**SILVERDALE CONVEYANCE SYSTEM AND PUMP STATION 4 UPGRADES  
 SCHEDULE C  
 CONTROL BUILDING  
 ELECTRICAL ROOM AND WET WELL PLAN - PLUMBING**

Drawing: **P-2C**  
 Sheet: **85** Of **117**  
 File: P21-10530-PS4\_P-2C  
 Date: January 2023

Path: I:\21021 Kitsap County PS 3 and 4 Upgrades\Working Drawings\PS4\_P-3C\_Plot.dwg; Jan 06, 2023, 07:53:21am, CAD User: kenh.  
 Xref Filename: I:\21-10530-PS4\_TB-Sub.dwg | X21-10530-PS4\_Ext.Bldg | X21-10530-PS4\_Prop.Bldg | X21-10530-PS4\_Prop.Mech | X21-10530-PS4\_Prop.Elec |

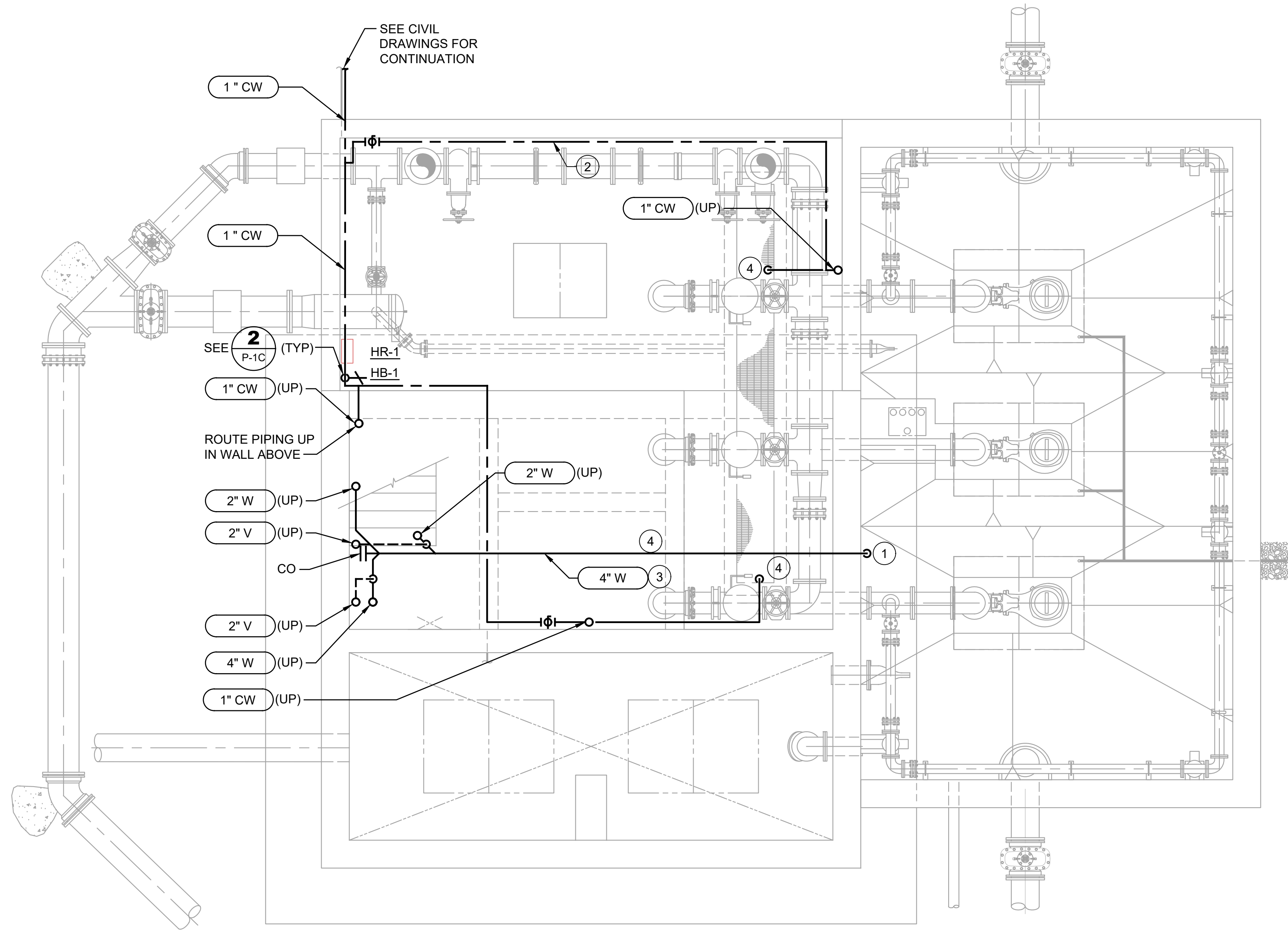

**PUMP STATION 4  
 PLUMBING - MID LEVEL  
 PLAN**  
 SCALE: 1/4" = 1'-0" **1**  
 P-3C

**NOTES:**

1. ALL BOLTED CONNECTIONS IN THE WET WELL SHALL BE CONSTRUCTED WITH DOUBLE 316L SST NUTS.
2. ALL BELL AND SPIGOT, MECHANICAL, AND PLAIN END JOINTS SHALL BE RESTRAINED.
3. COORDINATE HATCH LOCATION WITH PUMP MANUFACTURER AND GUIDE RAILS TO AVOID CONFLICTS. ALL ACCESS HATCHES SHALL HAVE A SAFETY GRATE BY HATCH MANUFACTURER UNLESS NOTED OTHERWISE. SAFETY GRATE SWING SHALL BE THE SAME AS THE HATCH DOOR. WATER PIPING SHALL NOT BE ROUTED DIRECTLY ABOVE ELECTRICAL EQUIPMENT.

**CONSTRUCTION NOTES:**

1. TERMINATE PIPE 12" BELOW ELBOW AND PROVIDE 4" DUCKBILL TYPE CHECK VALVE.
2. INSTALL PIPE 1'-0" BELOW CEILING. SLEEVE PIPE THROUGH BEAM.
3. INSTALL WASTE PIPING FROM BEAMS IN CEILING OF PIPE ROOM WHILE MAINTAINING 2% SLOPE.
4. ROUTE DRAIN PIPING TO TRENCH

**Call 48 Hours  
 Before You Dig**

**1-800-424-5555**  
 UNDERGROUND SERVICE



No.	Revision	Date	By	App'd

**bhc**  
 CONSULTANTS  
 BHC Consultants, LLC  
 1801 Fifth Avenue, Suite 500  
 Seattle, Washington 98101  
 206.505.3400  
 206.505.3406 (fax)  
 www.bhcconsultants.com

**fsi**  
 ENGINEERS  
 Seattle // Spokane // Baltimore

Designed: ELL  
 Drawn: KH  
 Checked: JOJ

Scale:  
 1/4" = 1'-0"  
 One Inch At Full Scale  
 If Not One Inch Scale Accordingly

**Kitsap County Public Works**  
 614 Division Street, MS 26  
 Port Orchard, WA 98366

**SILVERDALE CONVEYANCE SYSTEM AND PUMP STATION 4 UPGRADES  
 SCHEDULE C  
 CONTROL BUILDING  
 PIPING ROOM AND WET WELL PLAN - PLUMBING**

Drawing: **P-3C**  
 Sheet: **86** Of **117**  
 File: P21-10530-PS4\_P-3C  
 Date: January 2023

**MOTORS AND POWER EQUIPMENT**

	GROUND ROD IN GROUND ROD BOX		SA SURGE ARRESTER
	TRANSFORMER		DISCONNECT OR SWITCH
	MOTOR STARTER W/ DISCONNECT		TRANSFORMER
	DISCONNECT SWITCH, NON FUSED (60A) INDICATES AMPERAGE RATING		15/1 THERMAL MAGNETIC CIRCUIT BREAKER, RATING/NO. POLES MO = MAGNETIC ONLY
	DISCONNECT SWITCH, FUSED 100=SWITCH RATING, 80=FUSE RATING		THERMAL OVERLOAD RELAY
	UTILITY METERING		ATS - AUTOMATIC TRANSFER SWITCH MTS - MANUAL TRANSFER SWITCH
	MOTOR		KXVAR POWER CAPACITOR WITH KVAR RATING
	EXHAUST FAN		VFD = VARIABLE FREQUENCY DRIVE VSD = VARIABLE SPEED DRIVE SSS = SOLID STATE STARTER
	PANELBOARD, SWITCHBOARD, MCC		GROUND TEST
	50A FUSE WITH AMPERE RATING		MOTOR - NUMBER "15" INDICATES HORSEPOWER
	PACKAGED POWER AND CONTROL PANEL		MS OR M = MOTOR STARTER CONTACTOR C = CONTACTOR, BP = BYPASS CONTACTOR IC = ISOLATION CONTACTOR
	UTILITY METERING		3 CURRENT TRANSFORMER, NUMBER "3" INDICATES NUMBER OF CTS
	GROUND		PULL OUT SWITCH/PLUG-RECEPTACLE CONNECTION
	SPD SURGE PROTECTIVE DEVICE		

**ELEMENTARY WIRING DIAGRAM SYMBOLS**

	N.O. NORMALLY OPEN		N.O. NORMALLY CLOSED		HOA = HAND/OFF/AUTO SWITCH
	SW SWITCH		PB PUSH BUTTON		INDICATING LIGHT R=RED, G=GREEN, A=AMBER, B=BLUE, W=WHITE
	NO CONTACT		CR CONTROL RELAY / CONTACTOR		CONTROL RELAY / CONTACTOR
	FS FLOW SWITCH		TDR TIME DELAY RELAY		TIME DELAY RELAY
	LS LEVEL SWITCH		TSP TWISTED SHIELDED PAIR (TSP)		TWISTED SHIELDED PAIR (TSP)
	PS PRESSURE SWITCH		SV SOLENOID VALVE		SOLENOID VALVE
	TS TEMPERATURE SWITCH		RTM RTM = RUN TIME METER, AMP = AMP METER, CNT = COUNTER		RTM = RUN TIME METER, AMP = AMP METER, CNT = COUNTER
	ZS LIMIT SWITCH		HMI HMI = OPERATOR CONTROL INTERFACE (VFD OPERATOR & DISPLAY)		HMI = OPERATOR CONTROL INTERFACE (VFD OPERATOR & DISPLAY)
	FT INSTRUMENT - FS = FLOW SWITCH, FT = FLOW XMTR, PS= PRESSURE SWITCH, PT = PRESSURE XMTR, ZS = LIMIT SWITCH, VS = VIBRATION SWITCH, VT = VIBRATION XMTR, MS = MOISTURE SWITCH, FE = FLOW ELEMENT, LE = LEVEL ELEMENT, TE = TEMP ELEMENT		RTM = RUN TIME METER, AMP = AMP METER, CNT = COUNTER		RTM = RUN TIME METER, AMP = AMP METER, CNT = COUNTER
	S INSTRUMENT - LS = LEVEL SWITCH, TS = TEMPERATURE SWITCH,		BATTERY		BATTERY
	H HEATER - HEAT TRACE		HORN		HORN
	K KIRK KEY INTERLOCK		BFI BLOWN FUSE INDICATOR		BLOWN FUSE INDICATOR
			IL INDICATING LIGHT: A = AMBER G = GREEN W = WHITE B = BLUE R = RED		INDICATING LIGHT: A = AMBER G = GREEN W = WHITE B = BLUE R = RED
			SS SELECTOR SWITCH: FOR = FORWARD/OFF/REVERSE HOR = HAND/OFF/REMOTE HOA = HAND/OFF/AUTO RO = RUN/OFF POT = POTENTIOMETER HIGH/OFF/LOW		SELECTOR SWITCH: FOR = FORWARD/OFF/REVERSE HOR = HAND/OFF/REMOTE HOA = HAND/OFF/AUTO RO = RUN/OFF POT = POTENTIOMETER HIGH/OFF/LOW

**RACEWAY SYMBOLS**

	A-4 CONDUIT RUN 3/4"Ø, UNLESS OTHERWISE SHOWN 4-#12 FOR POWER CIRCUITS TO PANEL "A" CKT "4"
	C-XX TAGGED CONDUIT RUN - SEE CONDUIT & WIRE SCHEDULE FOR DETAILS. P=POWER, C=CONTROL, S=SIGNAL
	D UNTAGGED CONDUIT RUN - CONTRACTOR TO PROVIDE RACEWAY FOR CONTROL OR SIGNAL WIRING AS REQUIRED BY THE EQUIPMENT, IN ACCORDANCE TO THE WIRING DIAGRAMS, OR AS SPECIFIED. CONDUIT SIZE PER NEC; MINIMUM 3/4" "C" = (120V) #14 CONTROL WIRE, #12 POWER WIRE "S" = TSP SIGNAL WIRE "D" = DEVICENET CABLE CONNECTION "E" = ETHERNET CABLE CONNECTION (CAT-5) "F" = FIRE ALARM PANEL CONNECTION PROVIDE # OF WIRES AS REQUIRED.
	CONDUIT TURNED UP OR TOWARD
	RACEWAY TURNED DOWN
	CONDUIT CONCEALED
	CONDUIT EXPOSED
	J CONDUIT JUNCTION BOX
	PB = PULL BOX, HH = HANDHOLE C=CONTROL, S=SIGNAL, P=POWER
	CONDUIT CAPPED
	CORD OR FLEXIBLE CONDUIT

**WIRE DIAGRAMS, ONE-LINES, MISC**

	EXISTING
	FUTURE
	PROPOSED WORK/EQUIPMENT
	CONDUCTORS NOT CONNECTED
	CONDUCTORS CONNECTED

**REFERENCE SYMBOLS**

	100.1 CONDUIT
	1 LIGHTS
	FIT-111 EQUIPMENT TAG
	1 CONSTRUCTION NOTE
	INSTRUMENT TYPE / FUNCTION
	INSTRUMENT DESIGNATION
	INSTRUMENT NUMBER

**LIGHTING & RECEPTACLE SYMBOLS**

**LIGHTING FIXTURES**

	LIGHTING FIXTURE
	STRIP LIGHTING FIXTURE
	WALL MOUNTED FIXTURE (SURFACE OR ARM)
	POLE ARM MOUNTED FIXTURE
	RECESSED LIGHT FIXTURE
	INFRARED FLOOD LIGHT FIXTURE
	EXIT LIGHT FIXTURE WALL MOUNTED
	EMERGENCY LIGHT FIXTURE WITH BATTERY BALLAST
	OCCUPANCY SENSOR CEILING MOUNTED

**SWITCHES**

	D DIMMER	2 DOUBLE POLE
	E EXISTING SWITCH	3 THREE WAY
	K KEY OPERATED SWITCH	4 FOUR WAY
	M MOTOR RATED	
	MC MOMENTARY CONTACT, THREE POSITION	a LOWER CASE = SWITCH LEG
	P SWITCH WITH PILOT LIGHT	
	R REOSTATE - SPEED CONTROL	
	T TIMER	
	WP WEATHER PROOF	
	XP EXPLOSION PROOF	
	O OCCUPANCY SENSOR	

**SPECIAL PURPOSE CONNECTIONS**

	2 SPECIAL PURPOSE EQUIPMENT CONNECTION
	4 SPECIAL PURPOSE EQUIPMENT CONNECTION WALL MOUNTED

**RECEPTACLE OUTLETS**

	2 GFCI DUPLEX RECEPTACLE OUTLET WALL MOUNTED (NEMA 5-15R UNLESS OTHERWISE SPECIFIED)
	6 WP QUADRUPLE RECEPTACLE OUTLET WALL MOUNTED
	DUPLEX RECEPTACLE OUTLET CEILING MOUNTED
	SINGLE RECEPTACLE
	4 SPECIAL PURPOSE RECEPTACLE OUTLET
	6 SPECIAL PURPOSE RECEPTACLE OUTLET WALL MOUNTED
	▲ DUPLEX DATA OUTLET (RJ45 STYLE) (2 PORTS UNLESS NOTED OTHERWISE)
	▲ SPECIAL NETWORK CONNECTION
	Φ Φ(X) SURFACE METAL RACEWAY WITH RECEPTACLE AT "X" OC

1, 2, 3, ETC ARE CIRCUIT NUMBERS OF PANEL BOARD TO WHICH OUTLET IS TO BE CONNECTED. REFER TO CIRCUIT SCHEDULE.

H	HORIZONTAL
WP	WEATHER PROOF
XP	EXPLOSION PROOF
GFCI	GROUND FAULT CIRCUIT INTERRUPTER
WPIU	WEATHER PROOF, IN USE

**ABBREVIATIONS**

A, AMP	AMPERE	M	METER, MOTOR
AC	AIR COMPRESSOR, ALTERNATING CURRENT	MCC	MOTOR CONTROL CENTER
AF	AMPERE FRAME	MCP	MAIN CONTROL PANEL
AFF	ABOVE FINISHED FLOOR	MFGR	MANUFACTURER
AI	ANALOG INPUT POINT (PLC)	MH	MANHOLE
AIC	AMPERES INTERRUPTING CAPACITY	MO	MAGNETIC ONLY (CIRCUIT BREAKER)
AIL	AMBER INDICATING LIGHT	MOV	MOTOR OPERATED VALVE
AL	ALARM	MS	MOTOR STARTER
ALT	ALTERNATOR	MTS	MANUAL TRANSFER SWITCH
AM	AMMETER	N	NEUTRAL
AO	ANALOG OUTPUT POINT (PLC)	NC	NORMALLY CLOSED
AS	AMPERE SWITCH	NEC	NATIONAL ELECTRICAL CODE
AT	AMPERE TRIP	NEMA	NATIONAL ELECTRICAL MANUFACTURERS ASSOCIATION
ATS	AUTOMATIC TRANSFER SWITCH	NF	NON FUSED
AWG	AMERICAN WIRE GAUGE	N.O.	NORMALLY OPEN
BAT	BATTERY	OI	OPERATOR INTERFACE
BC	BATTERY CHARGER	OIT	OPERATOR IN TROUBLE
BH	BLOCK HEATER	OL	OVERLOAD RELAY
BIL	BLUE INDICATING LIGHT	OT	OVER TEMP
BKR	BREAKER	P	POWER
BP	BYPASS CONTRACTOR	PB	PUSH BUTTON
C	CONDUIT, CONTROL	PBC	PULLBOX (CONTROL)
CAP	CAPACITOR	PBD	PULLBOX (DATA)
CB	CIRCUIT BREAKER	PBL	PULLBOX - LIGHTED
CKT	CIRCUIT	PBP	PULLBOX (POWER)
CNT	START COUNTER	PBS	PULLBOX (SIGNAL)
CP	CONTROL PANEL	PE	PHOTO ELECTRIC RELAY
CPT	CONTROL POWER TRANSFORMER	PFR	PHASE FAILURE RELAY
CR	CONTROL RELAY	PLC	PROGRAMMABLE LOGIC CONTROLLER
CT	CURRENT TRANSFORMER	PMD	POWER MONITORING DEVICE
CU	COPPER	PNL	PANEL
CV	CHECK VALVE	POT	POTENTIOMETER
DB	DIRECT BURIED	PS	PRESSURE SWITCH, PUMP STATION
DC	DIRECT CURRENT	PT	POTENTIAL TRANSFORMER
DEM	DEMAND	PVC	POLYVINYL CHLORIDE (CONDUIT)
DF	DEMAND FACTOR	RCP	REMOTE CONTROL PANEL
DI	AC DIGITAL INPUT POINT (PLC)	RIL	RED INDICATING LIGHT
DM	DIGITAL METER	RO	RUN - OFF
DO	AC DIGITAL OUTPUT POINT (PLC)	RTD	RESISTANCE TEMPERATURE DEVICE
DWG	DRAWING	RTM	RUN TIME METER
EF	EXHAUST FAN	RV	REDUCED VOLTAGE
ENCL	ENCLOSURE	RVAT	REDUCED VOLTAGE AUTO TRANSFORMER
EX	EXISTING	S	STARTER
F	FUSED	SA	SIGNAL SURGE ARRESTOR
FACP	FIRE ALARM CONTROL PANEL	SCL	SEATTLE CITY LIGHT
FS	FLOW SWITCH	SE	SERVICE ENTRANCE
FT	FLOW TRANSMITTER	SPD	SURGE PROTECTIVE DEVICE
FTB	FLUIDIZED THERMAL BACKFILL	SST	STAINLESS STEEL
FVNR	FULL VOLTAGE NON-REVERSING	SSS	SOLID STATE STARTER
FU	FUSE	SV	SOLENOID VALVE
FVR	FULL VOLTAGE REVERSING	T	THERMOSTAT
G, GND	GROUND	TC	TIME CLOCK
GEN	GENERATOR	TDOD	TIME DELAY ON DE-ENERGIZATION
GFI	GROUND FAULT INTERRUPTER	TDOE	TIME DELAY ON ENERGIZATION
GFP	GROUND FAULT PROTECTOR	TDR	TIME DELAY RELAY
GIL	GREEN INDICATING LIGHT	TEL	TELEPHONE
GRS	(GRC) GALVANIZED RIGID STEEL (CONDUIT)	TNI	TELEPHONE NETWORK INTERFACE
H	HOT, HIGH, HAND	TS	TEMPERATURE SWITCH
HH	HAND HOLE	TSP	TWISTED SHIELDED PAIR
HID	HIGH INTENSITY DISCHARGE	TST	TWISTED SHIELDED THREE WIRE
HMI	HUMAN MACHINE INTERFACE	TVSS	TRANSIENT VOLTAGE SURGE SUPPRESSER
HOA	HAND OFF AUTO (SELECTOR SWITCH)	TYP	TYPICAL
HP	HORSEPOWER	UH	UNIT HEATER
HS	HAND STATION (HOA SWITCH & POT)	UPS	UNINTERRUPTIBLE POWER SUPPLY
HTR	HEATER	V	VOLT
IC	ISOLATION CONTRACTOR	VS	FLOW (VELOCITY) SWITCH
ISR	INTRINSICALLY SAFE RELAY	VFD	VARIABLE FREQUENCY DRIVE
KVA	KILO VOLT AMPS	VSD	VARIABLE SPEED DRIVE
KVAR	KILO VOLT AMP REACTIVE	W	WATT
KVARH	KILOVATT HOUR	WHM	WATT HOUR METER
KW	KILOWATT	WIL	WHITE INDICATING LIGHT
KWH	KILOWATT HOUR	WP	WEATHER PROOF
L	LOW, LIGHT	XFMR	TRANSFORMER
LC	LIGHTING CONTACTOR	XP	EXPLOSION PROOF
LCP	LOCAL CONTROL PANEL	XMTR	TRANSMITTER
LE	LEVEL ELEMENT	ZS	LIMIT SWITCH
LS	LEVEL SWITCH		
LT	LEVEL TRANSMITTER		
LTG	LIGHTING		

Path: S:\CAD\Kitsap County\21-10530 Silverdale Conveyance-PS 4 UprgrDesign\Drawings\21-10530\_E-1C\_Pkg.dwg, Jan 05, 2023, 04:35:22pm CAD User: solboe, Xref Filename: 1\21-10530\_TB\Palmatier\Dan\1\Fisher1

**Call 48 Hours Before You Dig**  
1-800-424-5555  
UNDERGROUND SERVICE



ISSUED FOR BID	01-2023	TF	RAD
No.	Revision	Date	By App'd

**bhc CONSULTANTS**  
206.505.3400  
206.505.3406 (fax)  
www.bhcconsultants.com

Designed: N. Palmatier, P.E.  
Drawn: P. Simon  
Checked: T. Fisher, P.E.

Scale: N/A  
One Inch at Full Scale  
If Not One Inch Scale Accordingly

**Kitsap County Public Works**  
614 Division Street, MS 26  
Port Orchard, WA 98366

**SILVERDALE CONVEYANCE SYSTEM AND PUMP STATION 4 UPGRADES SCHEDULE C**

**ELECTRICAL SYMBOLS AND ABBREVIATIONS**

Drawing:	<b>E-1C</b>
Sheet:	<b>87</b> of <b>117</b>
File:	P21-10530_E-1C
Date:	January 2023

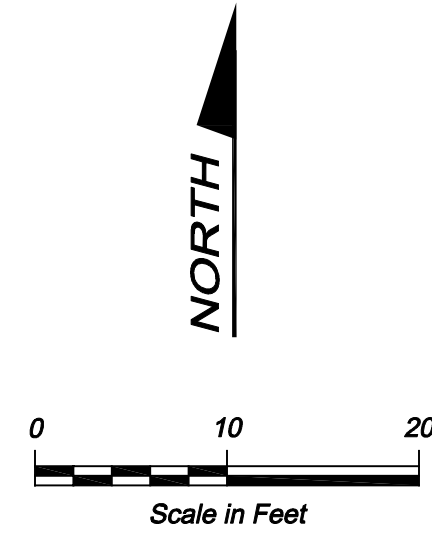

Plat of  
BUCKLIN TERRACE  
Vol.9 Pg.22 2

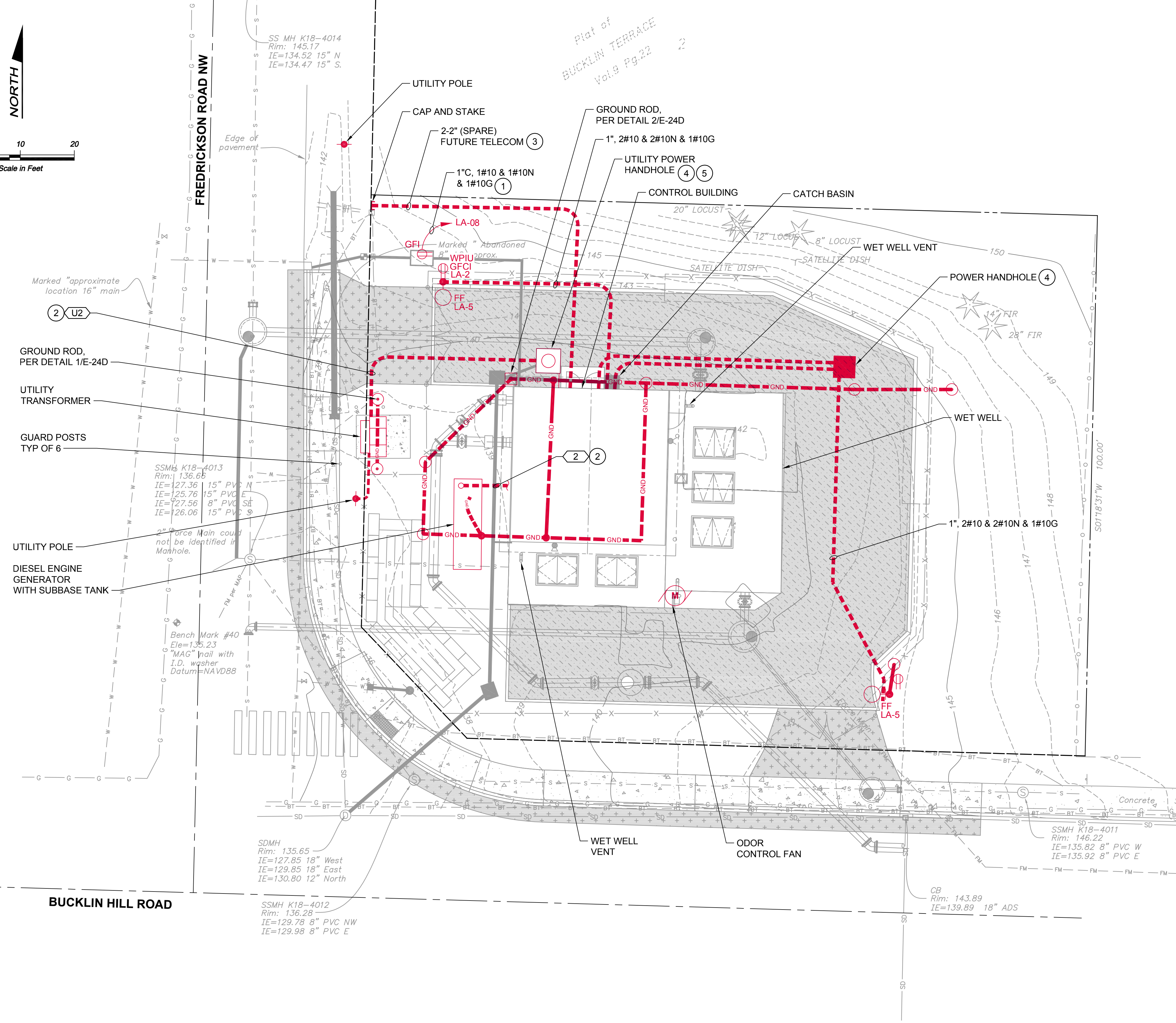

**NOTES:**

- COORDINATE WITH UTILITY AND PROVIDE TO UTILITY REQUIREMENTS.  
 PUGET SOUND ENERGY:  
 PERSON LASTNAME, PROJECT MANAGER  
 (###) ### ####
- PROVIDE THE FOLLOWING:
- EXCAVATE THE VAULT AND HANDHOLE LOCATION.
  - REMOVE DEBRIS AND LEVEL THE BOTTOM OF THE EXCAVATION WITH A 6-INCH BASE OF CRUSHED ROCK.
  - BACKFILL THE EXCAVATION TO FINISHED GRADE AT 2 INCHES BELOW THE VAULT TOP.
  - GROUT AROUND SERVICE CONDUITS THAT ENTER INTO PSE VAULTS. CONDUITS MAY ONLY ENTER THROUGH MOUSE HOLE OPENINGS OR KNOCKOUTS.
  - SEAL SERVICE ENTRY CONDUIT AT PSE'S VAULT TO PREVENT WATER FROM ENTERING INTO YOUR SERVICE PANEL.

THE MINIMUM TRENCH WIDTH IS 18 INCHES; HOWEVER, THE EXCAVATOR MAY NEED TO INCREASE THE TRENCH WIDTH DEPENDING ON THE OTHER CONDUITS/LINES BEING INSTALLED IN THE TRENCH.

TRAIN THE CABLE AND MARK THE RUNS:  
 • LABEL EACH CABLE'S PHASE AND THE NEUTRALS.  
 • LEAVE 30 FEET OF CABLE COILED IN THE VAULT.

- PROVIDE GROUNDING SYSTEM : EXOTHERMICALLY WELDS ALL CONNECTIONS UNLESS NOTED OTHERWISE. DO NOT CONNECT BUILDING GROUNDING SYSTEM TO ELECTRICAL UTILITY GROUNDING SYSTEM UNLESS DIRECTED TO DO SO BY THE ELECTRICAL UTILITY. THE GROUNDING ELECTRODE CONDUCTOR SHALL BE #1/0 UNLESS NOTED OTHERWISE.
  - #3/0 GROUNDING RING
  - #1/0 CONCRETE ENCASED STRUCTURAL MEMBERS (UFER)
  - #1/0 WATER UTILITY PIPE CONNECTION (2)
  - #1/0 GROUND ROD, TYP
  - #1/0 SERVICE ENTRANCE SWITCHBOARD
  - #1/0 GENERATOR INLET RECEPTACLE PANEL
  - #1/0 MOTOR CONTROL CENTER (3)
  - #1/0 AUTOMATIC TRANSFER SWITCH (2)
  - #1/0 DIESEL ENGINE GENERATOR
  - #2 PANEL LA
  - #2 TRANSFORMER TLA
  - #8 MAIN CONTROL PANEL
  - #8 MAGNETIC FLOW METER
  - #8 HANDHOLE LIDS (2)
  - #8 PUMP MOTOR TERMINAL JUNCTION BOXES (3)
  - #8 WET WELL EQUIPMENT AND HATCHES (5)
- INSTALL OWNER FURNISHED ENGINE GENERATOR.
- SEE DWG E-30C FOR CIRCUIT INFORMATION.

**CONSTRUCTION NOTES:**

- PROVIDE METAL DETECTABLE STAKE, 3/4" REBAR OR LARGER
- LINES REPRESENT MULTIPLE CONDUITS
- TERMINATE CONDUITS FOR FUTURE TELECOM CIRCUITS IN JUNCTION BOX IN LOWER LEVEL OF PUMP STATION
- SEE DETAIL 5/E-24C. CONNECT AND HARD PIPE DRAIN TO CATCH BASIN
- SERVICE CONDUITS ENTER BUILDING. ENCASE IN CONCRETE OR CONSTANT DENSITY FILL WITHIN 36 INCHES OF EXTERIOR WALL. ENCASE SERVICE CONDUITS WITHIN PUMP STATIONS BETWEEN EXTERIOR WALL AND HOUSEKEEPING PAD UNDER SWITCHBOARD. SEE STRUCTURAL DETAILS FOR ENCASUREMENT REQUIREMENTS WITHIN BUILDING. SEE DETAIL 7/E-24 FOR GENERAL ENCASUREMENT REQUIREMENTS.

**Call 48 Hours Before You Dig**  
 1-800-424-5555  
 UNDERGROUND SERVICE

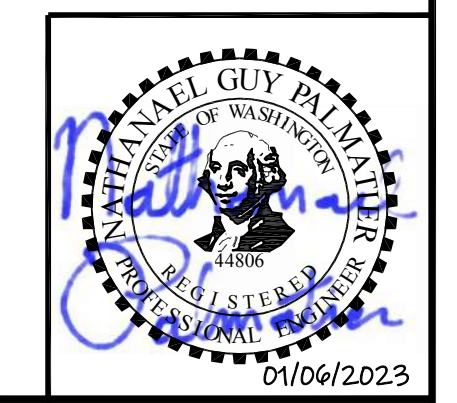

Path: S:\Cadd\Kitsap County\21-10530 Silverdale Convey-PS-4 Uprtg\Design\Drawings\21-10530\_E-2C\_Pkg.dwg, Jan 06, 2023, 08:47:21am CAD User: solsoe  
 Xref Filename: I:\Fisher\21-10530\_PSA\_Prop\PSA\_Prop\PSA\_Prop\PSA\_Prop.dwg, Xref Path: I:\Fisher\21-10530\_PSA\_Prop\PSA\_Prop\PSA\_Prop.dwg, Xref Topo: [Data]

No.	Revision	Date	By	App'd
	ISSUED FOR BID	01-2023	TF	RAD

**bhc CONSULTANTS**  
 BHC Consultants, LLC  
 1601 Fifth Avenue, Suite 500  
 Seattle, Washington 98101  
 206.505.3400  
 206.505.3406 (fax)  
 www.bhcconsultants.com

Designed: N. Palmatier, P.E.	Scale: 1" = 10'-0"
Drawn: A. Bradley	One Inch at Full Scale
Checked: R. Dorn, P.E.	If Not One Inch Scale Accordingly

**Kitsap County Public Works**  
 614 Division Street, MS 26  
 Port Orchard, WA 98366

**SILVERDALE CONVEYANCE SYSTEM AND PUMP STATION 4 UPGRADES SCHEDULE C**  
**ELECTRICAL SITE PLAN**

Drawing:	<b>E-2C</b>
Sheet:	<b>88</b> of <b>117</b>
File:	P21-10530_E-2C
Date:	January 2023



Path: S:\Cadd\Kitsap County\21-10530 Silverdale Conveyance\PS-4 Upgr\Design\Drawings\21-10530-E-3C ELEC.dwg, P21-10530-E-3C ELEC.dwg, Jan 06, 2023 08:50:15am CAD User: salsace  
 Xref Filename: 21-10530-PS4\_Prop Elec | 21-10530-PS4\_Ex Bldg | Palmatier | 21-10530-PS4\_Prop Grid | 21-10530-TB | Dahl | Fisher |

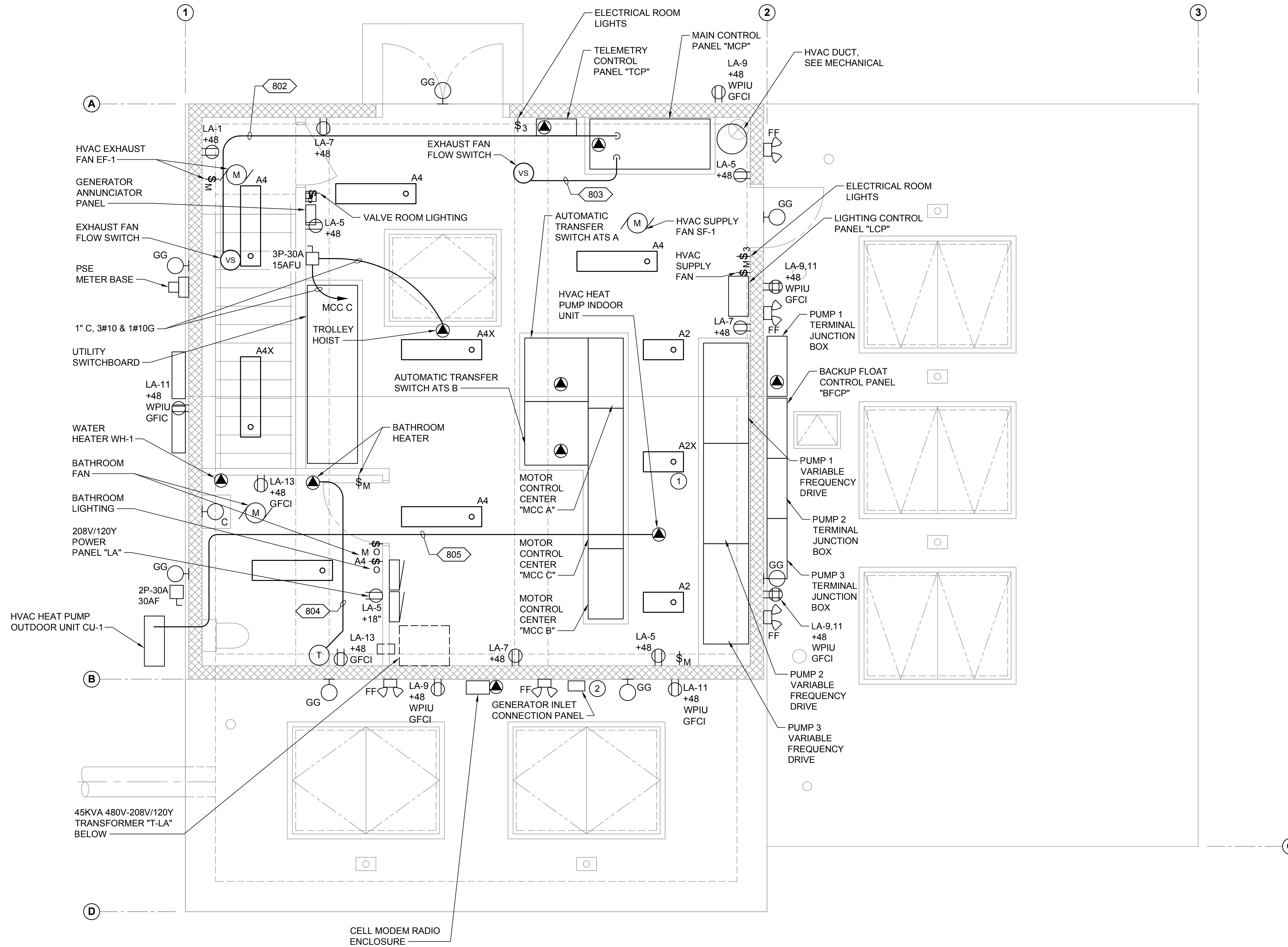

**NOTES:**

1. MOUNT INTERIOR LIGHT FIXTURES AT 8'-0" ABOVE FINISHED FLOOR UNLESS NOTED OTHERWISE. MOUNT EXTERIOR LIGHT FIXTURES AT 10'-0" UNLESS NOTED OTHERWISE OR SHOWN OTHERWISE ON ARCHITECTURAL ELEVATIONS.
2. PROVIDE ALL RECEPTACLES WITH GFCI.
3. PROVIDE A MINIMUM CIRCUIT OF 3/4"C, 1#10 & 1#10N & 1#10G FOR EACH DEVICE TO 208V/120Y PANEL "LA".
4. SEE DWG E-28C AND E-30C FOR CIRCUIT INFORMATION.

**CONSTRUCTION NOTES:**

- ① PROVIDE FIXTURE WITH 90 MINUTE BATTERY BACK, CONFIGURE FOR ALWAYS-ON.
- ② MOUNT GENERATOR INLET RECEPTACLE BOX WITH BOTTOM AT 36" ABOVE FINISHED GRADE.

**Call 48 Hours Before You Dig**  
 1-800-424-5555  
 UNDERGROUND SERVICE

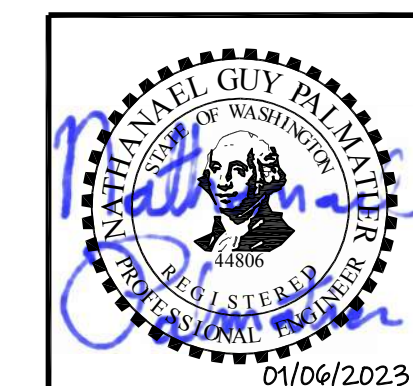

01/06/2023

No.	Revision	Date	By	App'd
	ISSUED FOR BID	01-2023	TF	RAD



**BHC Consultants, LLC**  
 1601 Fifth Avenue, Suite 500  
 Seattle, Washington 98101  
 206.505.3400  
 206.505.3406 (fax)  
 www.bhcconsultants.com

Designed: N. Palmatier, P.E.

Drawn: J. Lira

Checked: R. Dorn, P.E.

Scale:

3/8"=1'-0"

One Inch at Full Scale  
 If Not One Inch Scale Accordingly



**Kitsap County Public Works**  
 614 Division Street, MS 26  
 Port Orchard, WA 98366

**SILVERDALE CONVEYANCE SYSTEM AND PUMP STATION 4 UPGRADES  
 SCHEDULE C  
 CONTROL BUILDING  
 LIGHTS AND RECEPTACLE PLAN**

Drawing: **E-3C**  
 Sheet: **89** of **117**  
 File: P21-10530-PS4\_E-3C  
 Date: January 2023

Path: S:\CAD\Kitsap County\21-10530 Silverdale Convey-PS 4 Upgr\Design\Drawings\21-10530-E-4C PIP Rm.dwg, Jan 06, 2023, 08:52:49am CAD User: solsoe  
 Xref Filename: | X21-10530-PS-4\_Ex Bldg | X21-10530-PS-4\_Prop Bldg | X21-10530-PS-4\_Prop Mech | X21-10530-PS-4\_Prop Elec | Dahl | Fisher |

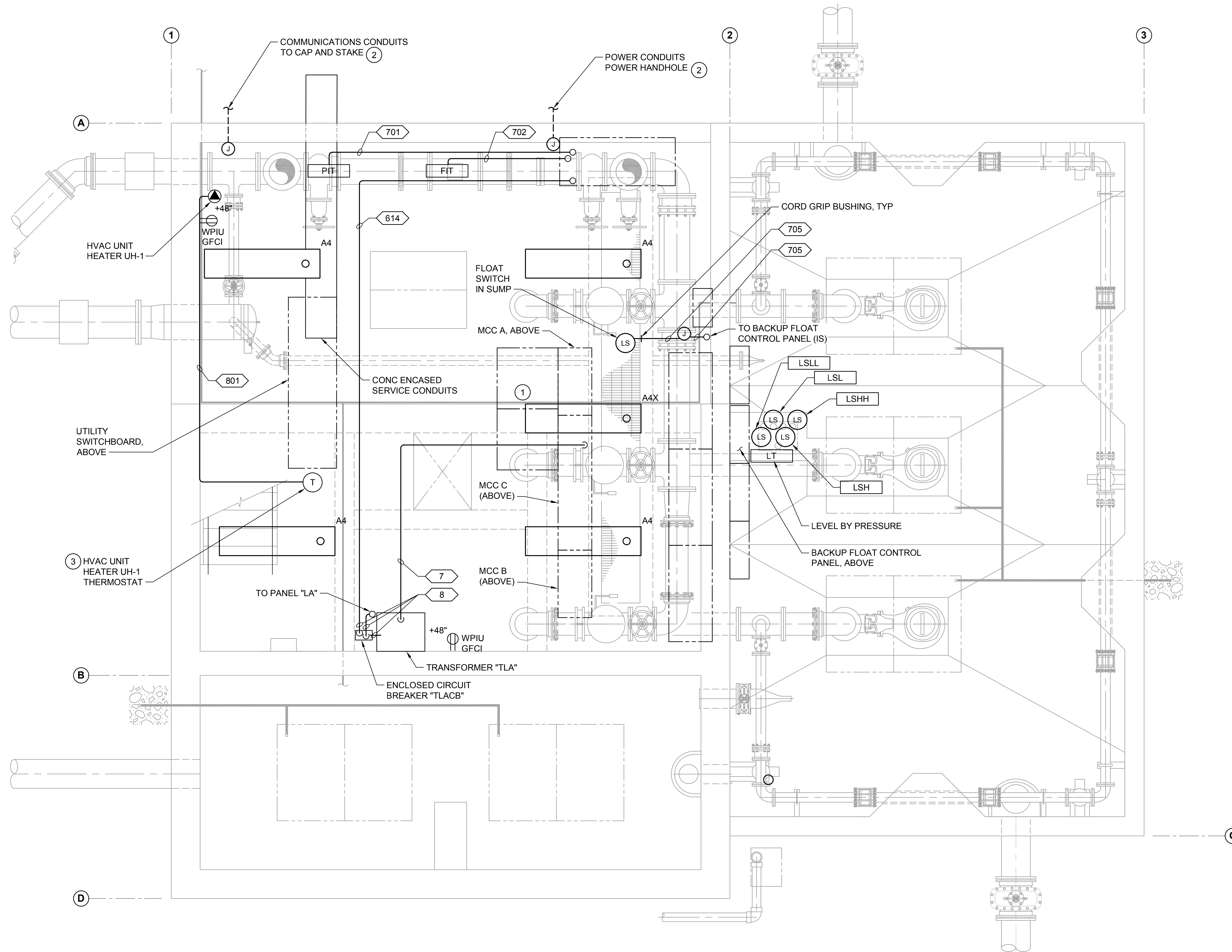

- NOTES:**
1. PROVIDE CHAIN HANG KIT OR OTHER MEANS TO MOUNT LIGHTING FIXTURES AT 8'-0" ABOVE FINISHED FLOOR.
  2. PROVIDE LIQUID-TIGHT CORD CONNECTIONS TO LIGHTING FIXTURES.
  3. FIXTURES IN VALVE ROOM ARE CONTROLLED BY PILOT LIGHT SNAP SWITCH ADJACENT TO VALVE ROOM DOOR IN ELECTRICAL ROOM.
  4. PROVIDE 3/4"C, 1#10 & 1#10N & 1#10G FOR EACH POWERED DEVICE TO PANEL LA UNLESS NOTED OTHERWISE.
  5. SEE DWG E-30C FOR CIRCUIT INFORMATION.

- CONSTRUCTION NOTES:**
- ① PROVIDE FIXTURE WITH 90 MINUTE BATTERY BACK, CONFIGURE FOR ALWAYS-ON.
  - ② PROVIDE 24" x 24" x 8" NEMA4 JUNCTION BOX ON WALL. POSITION ABOVE MECHANICAL PIPE. PROVIDE ENCLOSURE DRAIN. PROVIDE 1/4" STANDOFF KIT FROM STRUCTURAL WALL TO PREVENT ACCUMULATION ON J-BOX ENCLOSURE.
  - ③ MOUNT HVAC THERMOSTAT ON STAIRCASE RAILING SUPPORTS.
  - ④ MOUNT TRANSFORMER ON WALL WITH BOTTOM AT LEAST 10 FEET ABOVE FINISHED FLOOR.

**Call 48 Hours Before You Dig**  
  
**1-800-424-5555**  
 UNDERGROUND SERVICE

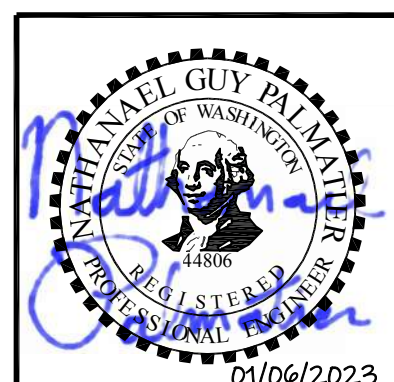

Drawing: **E-4C**  
 Sheet: **90** of **117**  
 File: P21-10530\_E-4C  
 Date: January 2023

No.	Revision	Date	By	App'd
	ISSUED FOR BID	01-2023	TF	RAD

**bhc**  
**CONSULTANTS**  
**BHC Consultants, LLC**  
 1601 Fifth Avenue, Suite 500  
 Seattle, Washington 98101  
 206.505.3400  
 206.505.3406 (fax)  
 www.bhcconsultants.com

Designed: N. Palmatier, P.E.  
 Drawn: J. Lira  
 Checked: R. Dorn, P.E.

Scale:  
 3/8" = 1'-0"  
 One Inch at Full Scale  
 If Not One Inch Scale Accordingly

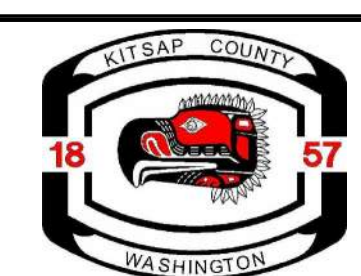

**Kitsap County Public Works**  
 614 Division Street, MS 26  
 Port Orchard, WA 98366

**SILVERDALE CONVEYANCE SYSTEM AND PUMP STATION 4 UPGRADES**  
**SCHEDULE C**  
**CONTROL BUILDING**  
**PIPING ROOM AND WET WELL**  
**LIGHTS AND RECEPTACLE PLAN**

Path: S:\Cadd\Kitsap County\21-10530 Silverdale Conveyance\PS4\_4 Upgr\Design\Drawings\21-10530\_E-5C\_Plot.dwg, Mar 20, 2023 03:27:38pm CAD User: solsoe  
 Xref Filename: | X21-10530-PS4\_Ext\_Bldg | X21-10530-TB | Palmatier | X21-10530-PS4\_Prop\_Elec | X21-10530-PS4\_Prop\_Bldg | X21-10530-TB | Palmatier | X21-10530-PS4\_Prop\_Grid | Dahl | Fisher |

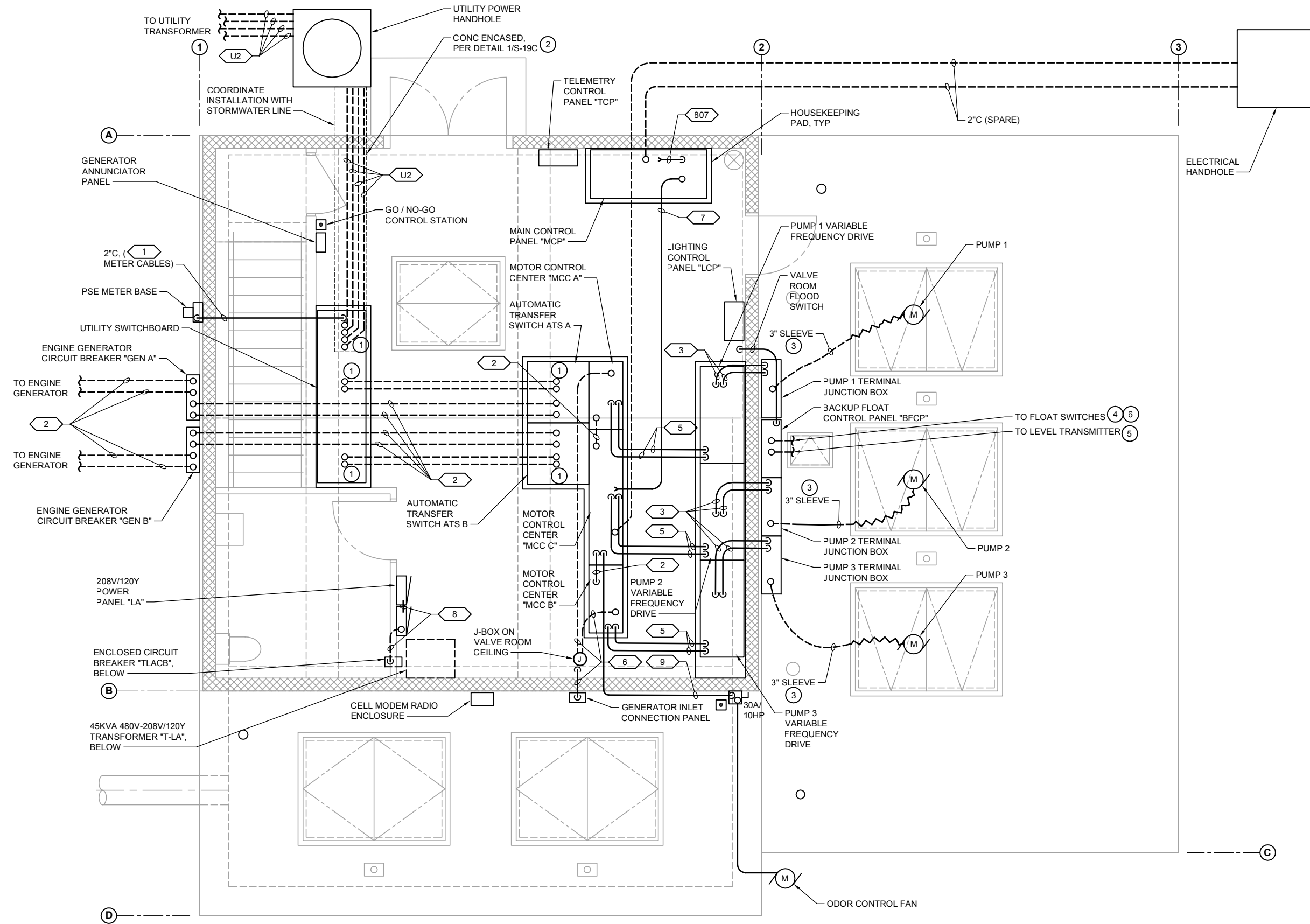

- NOTES:**
1. PROVIDE CONDUIT RE-ENTERABLE SEAL.
  2. SEE DWG E-30C FOR CIRCUIT INFORMATION.

- CONSTRUCTION NOTES:**
- 1 PROVIDE 5" SLEEVE IN BEAM; COORDINATE WITH STRUCTURAL. PROVIDE NON-SHRINK GROUT AROUND CONDUIT WITHIN SLEEVE.
  - 2 PROVIDE CONCRETE ENCASEMENT FROM HANDHOLE TO SWITCHBOARD. SEE DWG S-19 FOR CONDUIT ENCASEMENT DETAIL.
  - 3 ROUTE MANUFACTURER CABLE IN CONDUIT SLEEVE. SUPPORT CONDUIT SLEEVE PER MECHANICAL DETAIL 5/E-24C.
  - 4 MULTIPLE DEVICE CORDS.
  - 5 SUPPORT EACH CORD WITH KELLUMS GRIP PER DETAIL 3/E-25C.
  - 6 SUPPORT EACH FLOAT CORD PER DETAIL 4/E-25C. PROVIDE SST HOOK RACK WITH SPACE FOR AT LEAST 5 DEVICES.

**Call 48 Hours Before You Dig**  
 1-800-424-5555  
 UNDERGROUND SERVICE

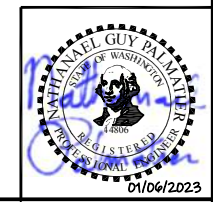

No.	Revision	Date	By	App'd
	ISSUED FOR BID	01-2023	TF	RAD



**BHC Consultants, LLC**  
 1601 Fifth Avenue, Suite 500  
 Seattle, Washington 98101  
 206.505.3400  
 206.505.3406 (fax)  
 www.bhcconsultants.com

Designed: N. Palmatier, P.E.  
 Drawn: J. Lira  
 Checked: R. Dorn, P.E.

Scale:  
 3/8"=1'-0"  
 One Inch at Full Scale  
 If Not One Inch Scale Accordingly



**Kitsap County Public Works**  
 614 Division Street, MS 26  
 Port Orchard, WA 98366

**SILVERDALE CONVEYANCE SYSTEM AND PUMP STATION 4 UPGRADES**  
 SCHEDULE C  
**CONTROL BUILDING**  
**ELECTRICAL ROOM AND WET WELL**  
**PROCESS POWER PLAN**

Drawing: **E-5C**  
 Sheet: **91** of **117**  
 File: P21-10530\_E-5C  
 Date: January 2023

Path: S:\Cadd\Kitsap County\21-10530 Silverdale Convey-PS 4 Uprgt\Design\Drawings\21-10530\_E-6C\_Pkg.dwg, File: 21-10530\_E-6C\_Pkg.dwg, Jan 06, 2023, 08:57:59am, CAD User: solsoe, Xref File: 21-10530-PS4\_Ext\_Bldg | 21-10530-PS4\_Prop\_Bldg | 21-10530-PS4\_Prop\_Elec | 21-10530-PS4\_Prop\_Grid | 21-10530-PS4\_Prop\_Hatch | 21-10530-PS4\_Prop\_Symbol | 21-10530-PS4\_Prop\_Text | 21-10530-PS4\_Prop\_Window

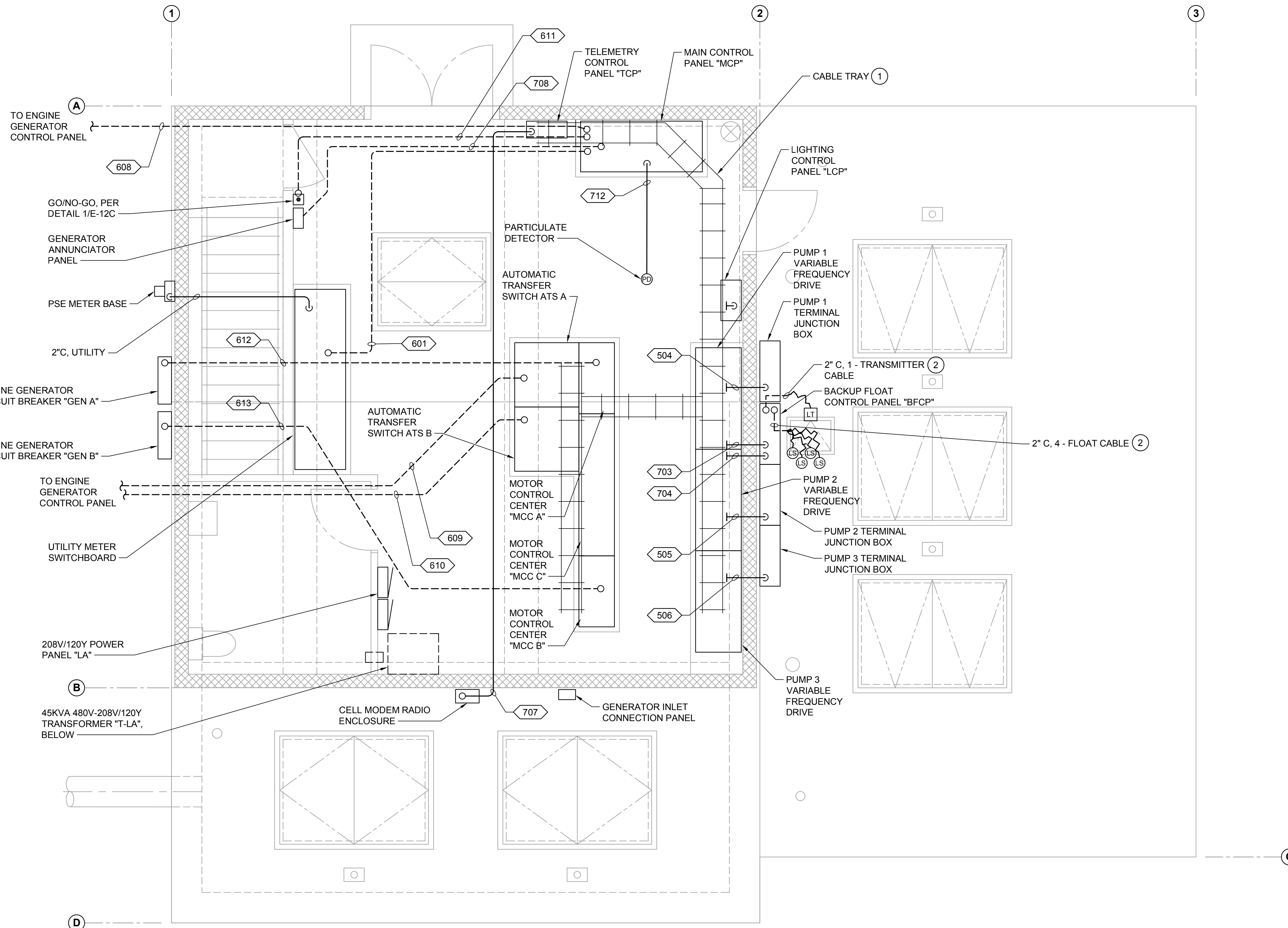

**NOTES:**

1. ROUTE CONDUITS WITH CABLE TRAY CIRCUITS TO WITHIN 1 INCH OF CABLE TRAY.

**CONSTRUCTION NOTES:**

- 1 PROVIDE CABLE TRAY FOR CONTROL DATA, AND SIGNAL, CIRCUITS. SIZE FOR CONDUCTORS WITH AT LEAST 30% SPARE CAPACITY. MINIMUM 12 INCH WIDTH. PROVIDE SUPPORT FROM ROOF STRUCTURAL MEMBERS OR BUILDING WALL. EXTEND EMT WITHIN ELECTRICAL ROOM TO CABLE TRAY. USE CORD-GRIP-BUSHING FROM ENCLOSURE TO CABLE TRAY. WATERFALL TRANSITIONS ARE ACCEPTABLE IN LIEU OF EXTENDING RACEWAY.
- 2 PROVIDE 2" SLEEVE UNDER BACKUP FLOAT CONTROL PANEL "BFCP" FOR FLOAT SWITCHES. PROVIDE 2" SLEEVE FOR LEVEL TRANSMITTER. ROUTE CABLES FROM BACKUP FLOAT CONTROL PANEL "BFCP" THROUGH SLEEVES. PROVIDE STAINLESS STEEL HOOK ASSEMBLY ASSESSIBLE THROUGH HATCH.
- 3 COORDINATE WITH THE UTILITY FOR CONDUCTORS AND ROUTING OF REVENUE METERING CIRCUITS. IN GENERAL, PROVIDE LONG RADIUS CONDUIT TURNS AND AVOID CONDUIT BODIES.

**Call 48 Hours Before You Dig**

**1-800-424-5555**  
UNDERGROUND SERVICE

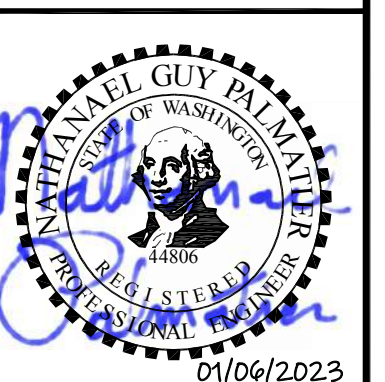

No.	Revision	Date	By	App'd
	ISSUED FOR BID	01-2023	TF	RAD



**BHC Consultants, LLC**  
1601 Fifth Avenue, Suite 500  
Seattle, Washington 98101  
206.505.3400  
206.505.3406 (fax)  
www.bhcconsultants.com

Designed: N. Palmatier, P.E.  
Drawn: J. Lira  
Checked: R. Dorn, P.E.

Scale:  
3/8"=1'-0"  
One Inch at Full Scale  
If Not One Inch Scale Accordingly



**Kitsap County Public Works**  
614 Division Street, MS 26  
Port Orchard, WA 98366

**SILVERDALE CONVEYANCE SYSTEM AND PUMP STATION 4 UPGRADES**  
**SCHEDULE C**  
**CONTROL BUILDING**  
**ELECTRICAL ROOM AND WET WELL**  
**INSTRUMENTATION AND CONTROL PLAN**

Drawing: **E-6C**  
Sheet: **92** of **117**  
File: P21-10530\_E-6C  
Date: January 2023



Path: S:\CAD\Kitsap County\21-10530 Silverdale Conveyance\PS 4\Upgr\Design\Drawings\21-10530\_E-8C P19.rvt Date: Jan 06, 2023 09:02:27am CAD User: solsoe  
 Xref Filename: 1\Palmatier\21-10530\_TB\Drawings\Fisher1

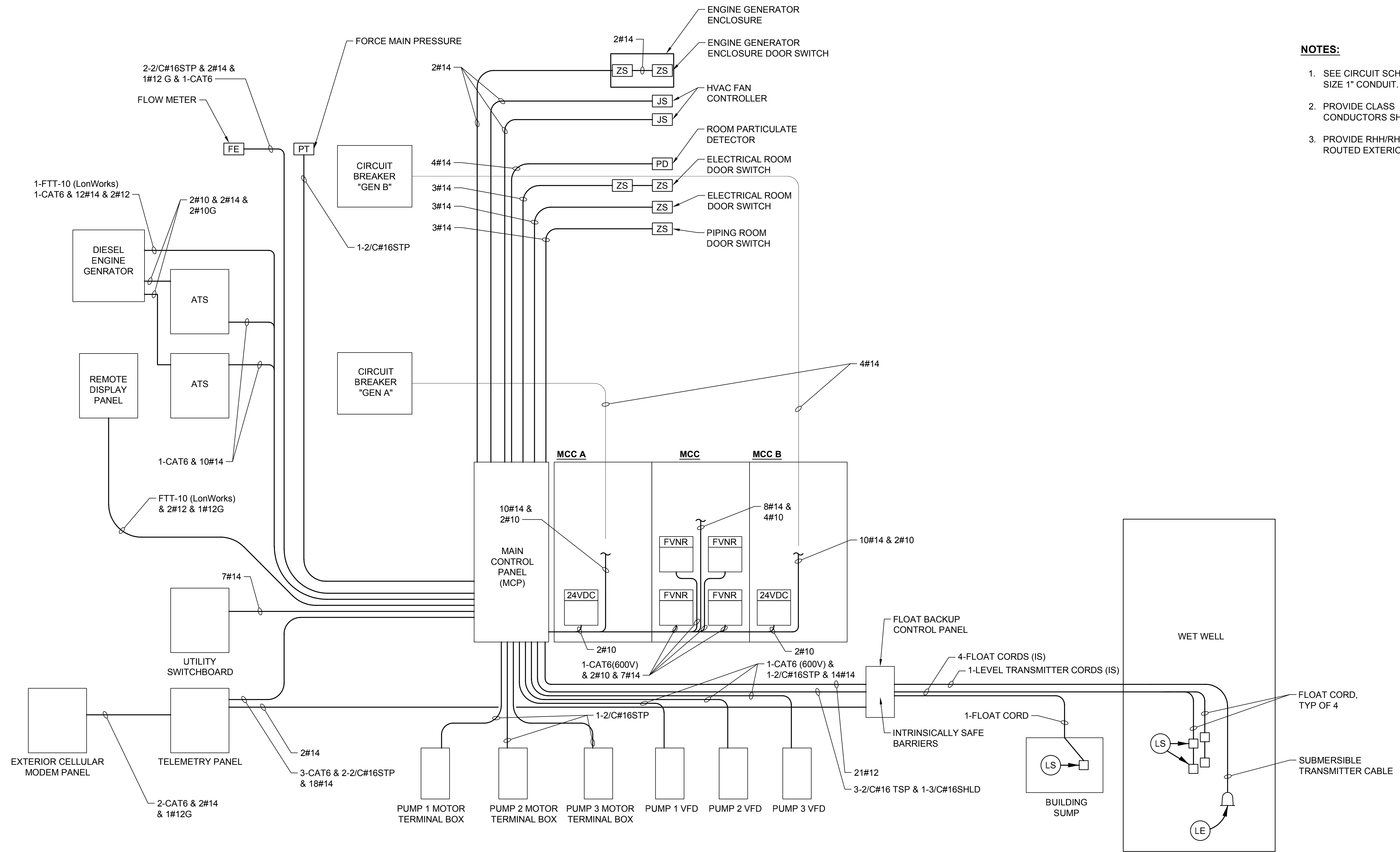

- NOTES:**
- SEE CIRCUIT SCHEDULE FOR CONDUIT SIZE. MINIMUM SIZE 1" CONDUIT.
  - PROVIDE CLASS C STRANDED CABLE FOR SINGLE CONDUCTORS SHOWN ON THIS PAGE.
  - PROVIDE RHH/RHW INSULATION FOR CONDUCTORS ROUTED EXTERIOR.

**CONTROL RISER DETAIL**  
 1  
 NTS

**Call 48 Hours Before You Dig**  
 1-800-424-5555  
 UNDERGROUND SERVICE

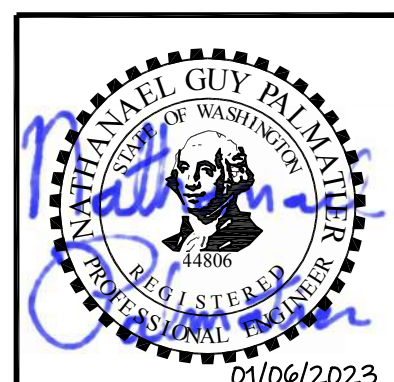

No.	Revision	Date	By	App'd
	ISSUED FOR BID	01-2023	TF	RAD



**BHC CONSULTANTS, LLC**  
 1601 Fifth Avenue, Suite 500  
 Seattle, Washington 98101  
 206.505.3400  
 206.505.3406 (fax)  
 www.bhcconsultants.com

Designed: N. Palmatier, P.E.  
 Drawn: J. Lira  
 Checked: R. Dorn, P.E.

Scale:  
 NTS  
 One Inch at Full Scale  
 If Not One Inch Scale Accordingly



**Kitsap County Public Works**  
 614 Division Street, MS 26  
 Port Orchard, WA 98366

**SILVERDALE CONVEYANCE SYSTEM AND PUMP STATION 4 UPGRADES**  
 SCHEDULE C  
**INSTRUMENTATION AND SIGNALS**  
 RISER DIAGRAM

Drawing: **E-8C**  
 Sheet: **94** of **117**  
 File: P19-10530\_E-8C  
 Date: January 2023

Path: S:\Cadd\Kitsap County\21-10530 Silverdale Convey-PS 4 Upgr\Design\Drawings\21-10530\_E-9C\_P10.dwg, Jan 06, 2023 09:04:18am CAD User: solsoe.  
 Xref Filename: I:\21-10530\_TB\Palmatier\Drawings\Fisher

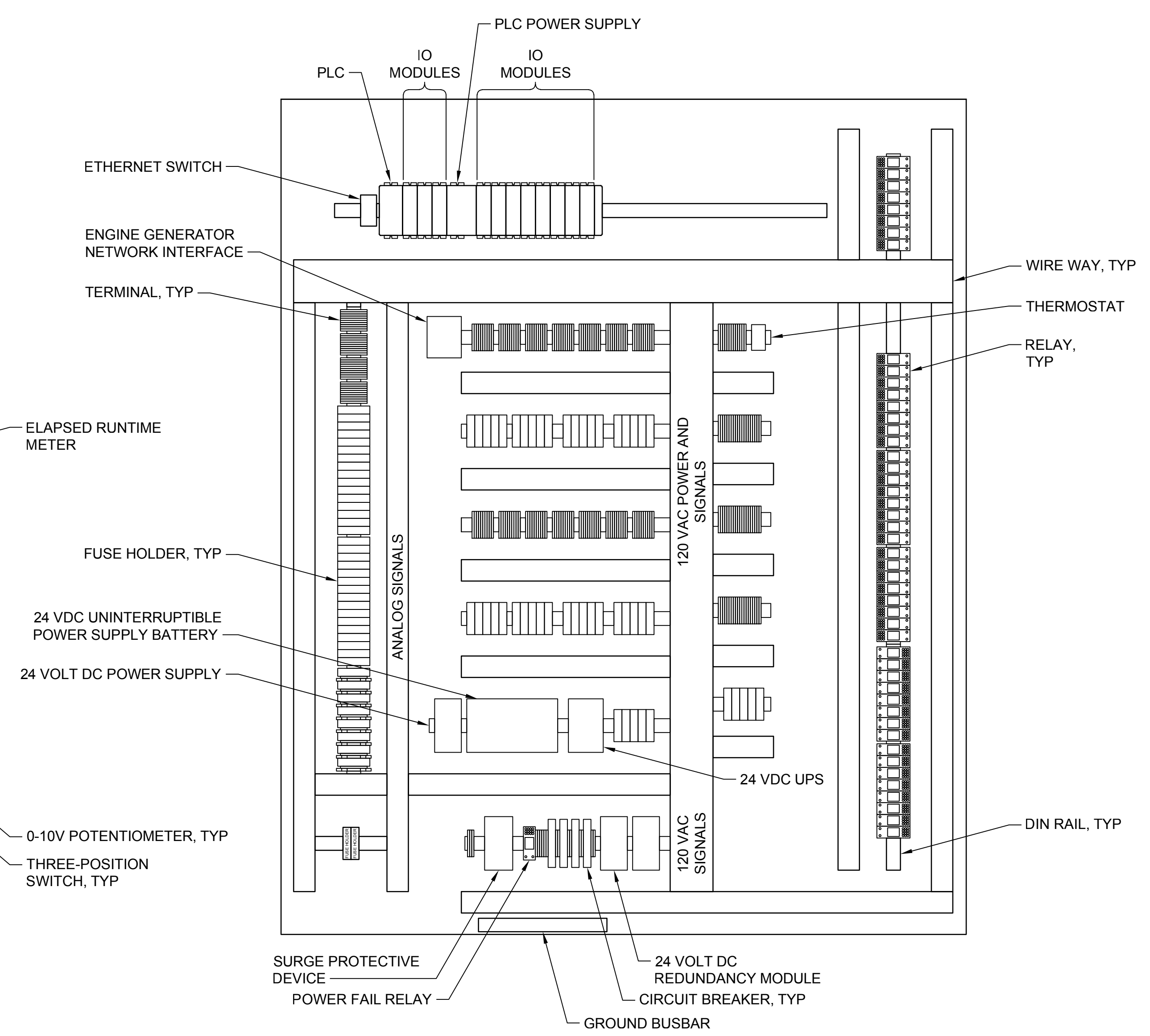
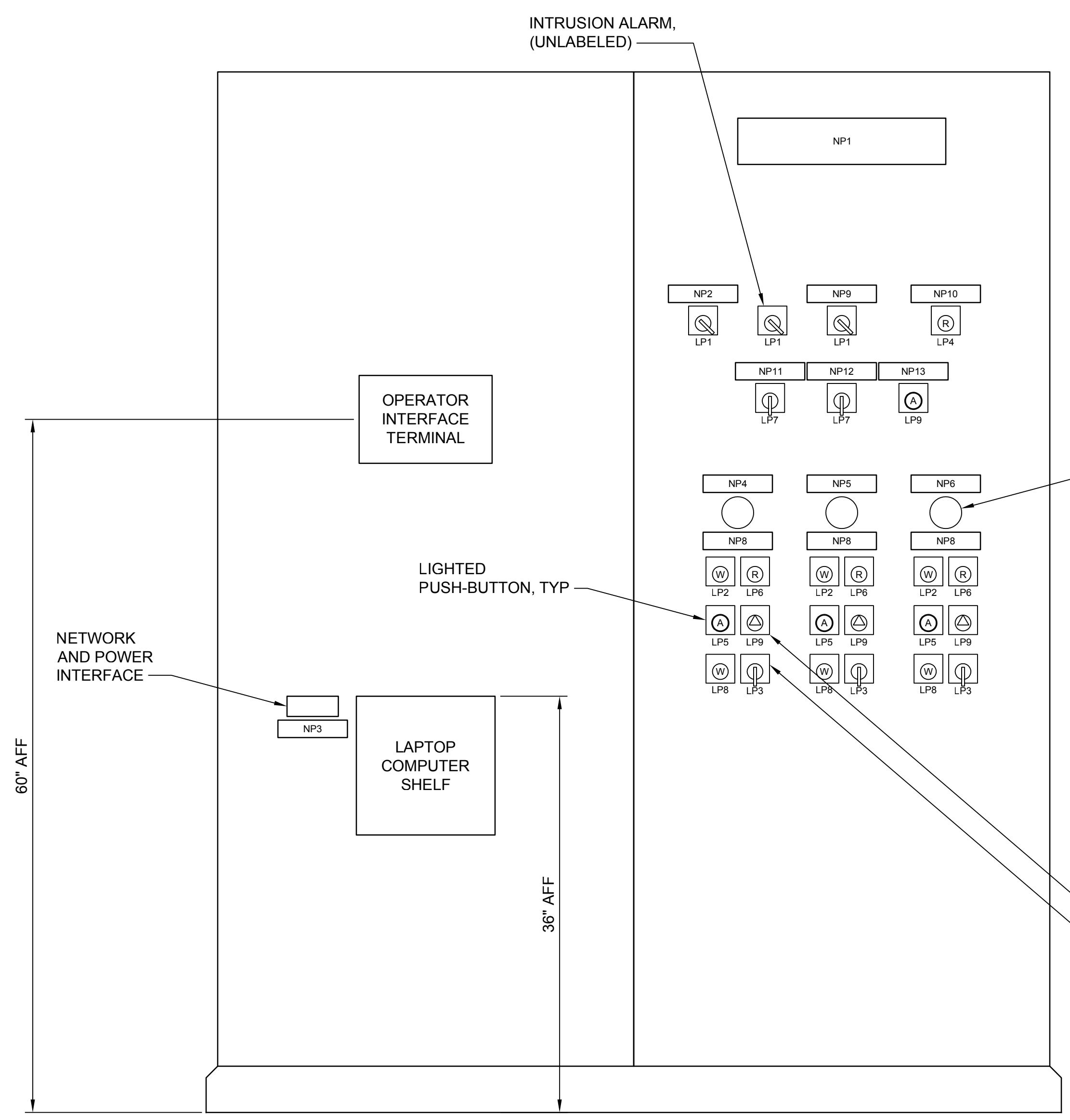

NAME PLATE SCHEDULE	
NP1	PUMP STATION 4 MAIN CONTROL PANEL (MCP) HAEDEN AND COLCHESTER DR SE
NP2	ALARM HORN ENABLE
NP3	RECEPTACLE FOR LAPTOP ONLY (2A MAX)
NP4	PUMP 1
NP5	PUMP 2
NP6	PUMP 3
NP7	PUMP STATION 4 FLOWMETER
NP8	RUNTIME (HRS)
NP9	ALARM HORN
NP10	HIGH FLOAT ALARM
NP11	LEAD SELECT
NP12	LAG SELECT
NP13	SELECT ERROR

LEGEND PLATE SCHEDULE	
LP1	OFF - ON
LP2	READY
LP3	HAND - OFF - AUTO
LP4	COMMON ALARM/RESET
LP5	FAULT/RESET
LP6	RUNNING
LP7	1 2 3
LP8	FOLLOW SELECTED
LP9	ERROR

**NOTES:**

1. THE COUNTY WILL PROVIDE THE ACTUAL STREET ADDRESS TO THE SUCCESSFUL CONTRACTOR AFTER AWARD. USE THE ACTUAL STREET ADDRESS.

**Call 48 Hours Before You Dig**  
 1-800-424-5555  
 UNDERGROUND SERVICE

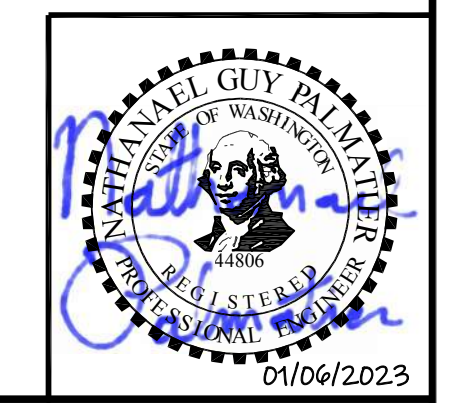

No.	Revision	Date	By	App'd
	ISSUED FOR BID	01-2023	TF	RAD

**bhc** CONSULTANTS  
**BHC Consultants, LLC**  
 1601 Fifth Avenue, Suite 500  
 Seattle, Washington 98101  
 206.505.3400  
 206.505.3406 (fax)  
 www.bhcconsultants.com

Designed: N. Palmatier, P.E.  
 Drawn: G. Castillo  
 Checked: R. Dorn, P.E.

Scale:  
 NTS  
 One Inch at Full Scale  
 If Not One Inch Scale Accordingly

**Kitsap County Public Works**  
 614 Division Street, MS 26  
 Port Orchard, WA 98366

**SILVERDALE CONVEYANCE SYSTEM AND PUMP STATION 4 UPGRADES SCHEDULE C**  
**ELECTRICAL**  
**MAIN CONTROL PANEL ELEVATIONS**

Drawing: **E-9C**  
 Sheet: **95** of **117**  
 File: P21-10530\_E-9C  
 Date: January 2023











Path: S:\Cadd\Kitsap County\21-10530 Silverdale Conveyance-PS 4 Uprgr\Design\Drawings\21-10530\_E-14C\_Plot.dwg Plot date: Jan 06, 2023 09:22:56am CAD User: soisce  
 Xref Filename: 21-10530\_TB | Palmatier | Datt | Fisher |

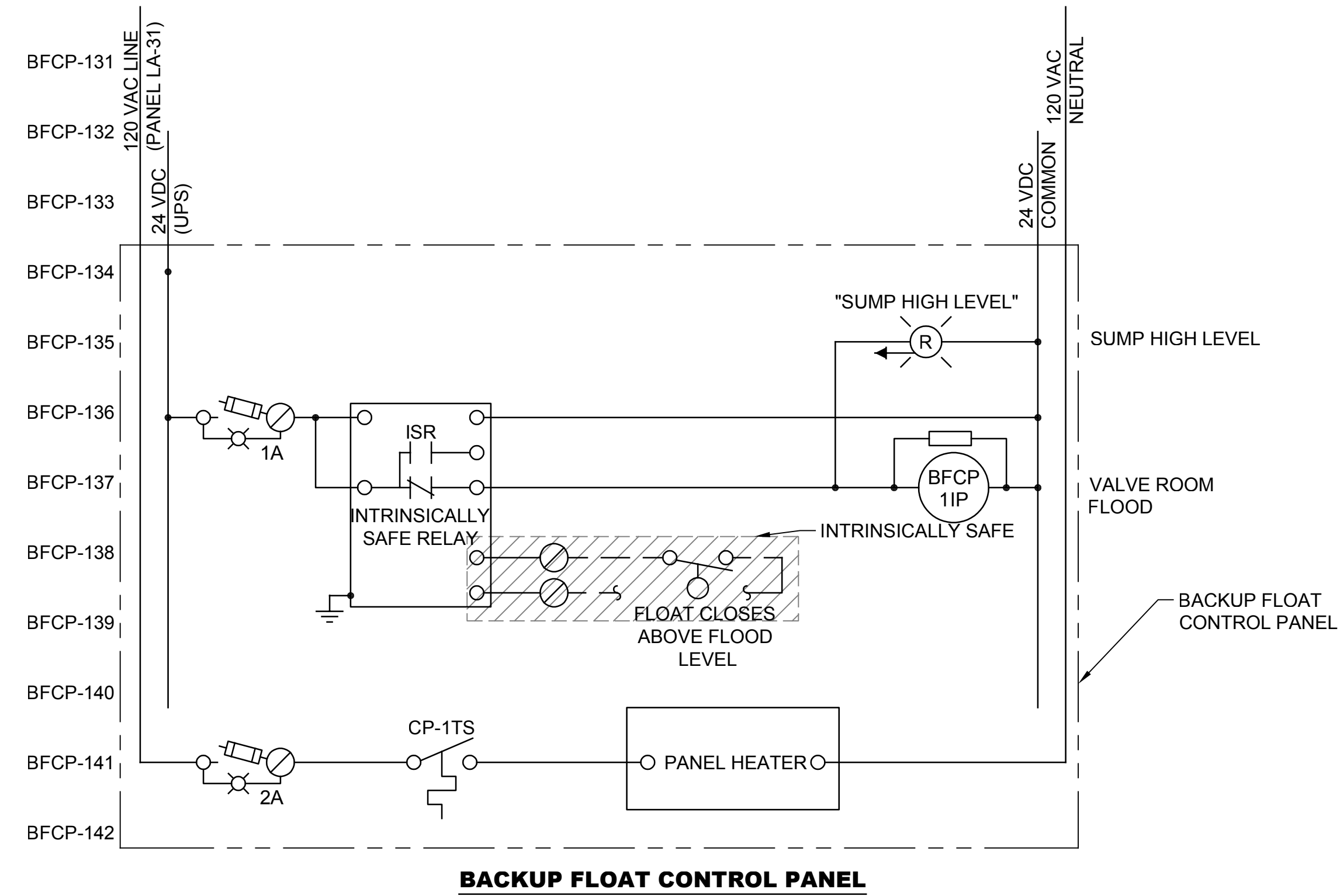
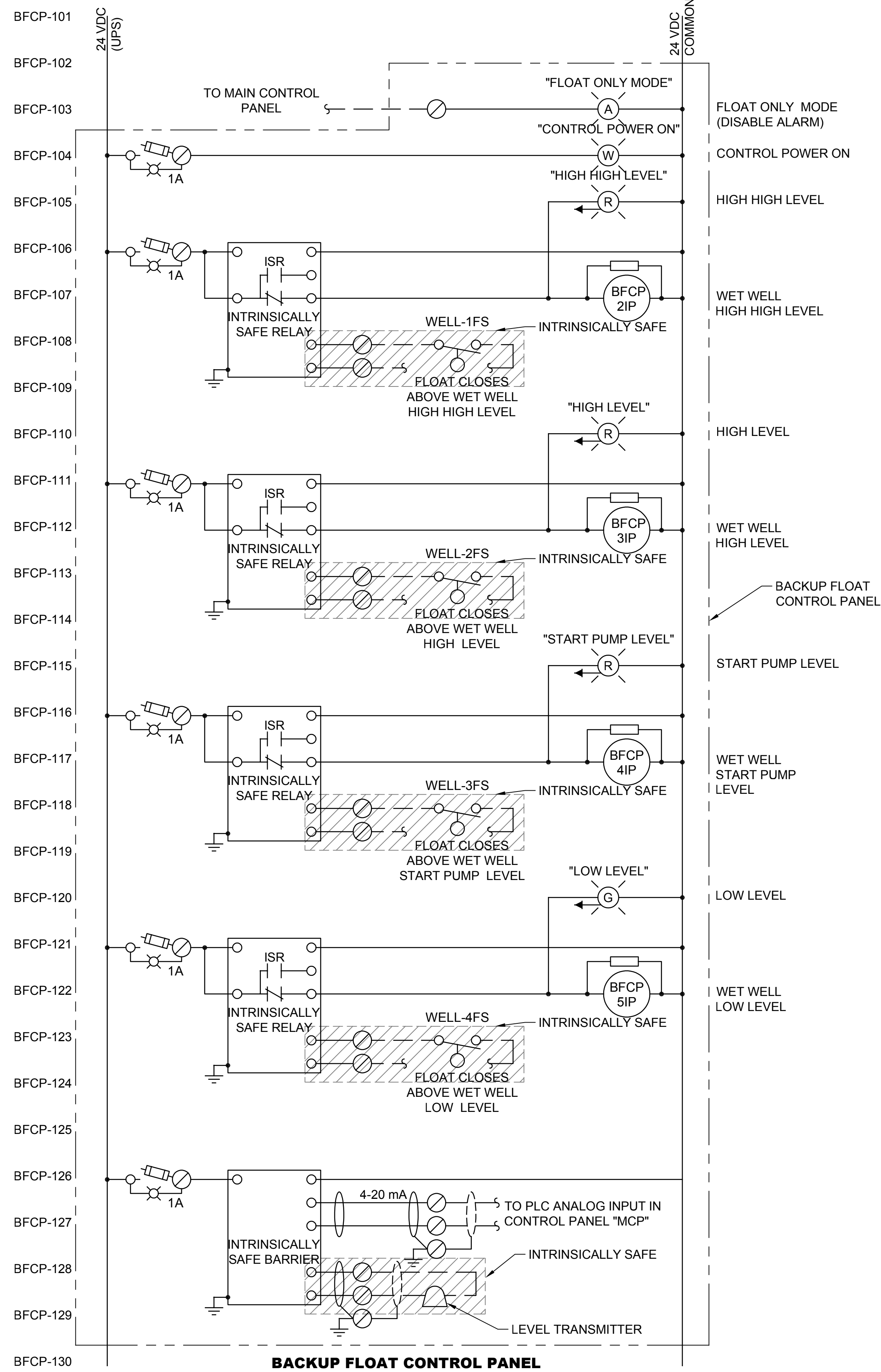

**BACKUP FLOAT CONTROL PANEL**

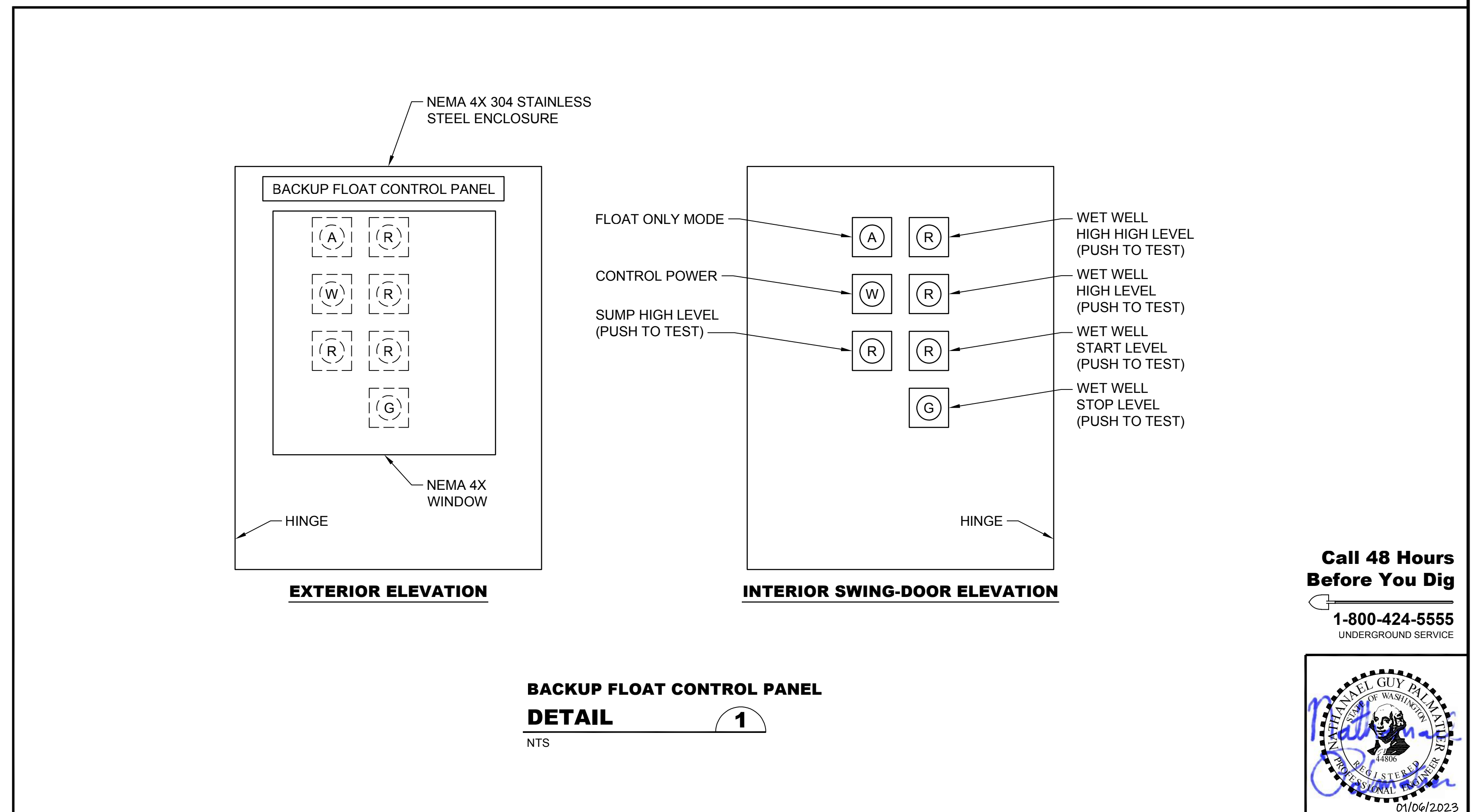

**EXTERIOR ELEVATION**

**INTERIOR SWING-DOOR ELEVATION**

**BACKUP FLOAT CONTROL PANEL**

**DETAIL 1**

NTS

**Call 48 Hours Before You Dig**

**1-800-424-5555**  
UNDERGROUND SERVICE



01/06/2023

No.	Revision	Date	By	App'd
	ISSUED FOR BID	01-2023	TF	RAD

**bhc**  
CONSULTANTS

**BHC Consultants, LLC**  
1601 Fifth Avenue, Suite 500  
Seattle, Washington 98101  
206.505.3400  
206.505.3406 (fax)  
www.bhcconsultants.com

Designed: N. Palmatier, P.E.  
Drawn: A. Bradley  
Checked: R. Dorn, P.E.

Scale:  
NTS  
One Inch at Full Scale  
If Not One Inch Scale Accordingly



**Kitsap County Public Works**  
614 Division Street, MS 26  
Port Orchard, WA 98366

**SILVERDALE CONVEYANCE SYSTEM AND PUMP STATION 4 UPGRADES**  
SCHEDULE C

**SCHEMATIC DIAGRAMS**  
**5 OF 7**

Drawing: **E-14C**  
Sheet: **100** of **117**  
File: P21-10530\_E-14C  
Date: January 2023

Path: S:\Cadd\Kitsap County\21-10530 Silverdale Convey-PS 4 Uprgr\Design\Drawings\21-10530\_E-15C\_Plot.dwg Plot date: Jan 06, 2023 09:31:04am CAD User: soisce  
 Xref Filename: 21-10530\_TB | Palmatier | Datt | Fisher |

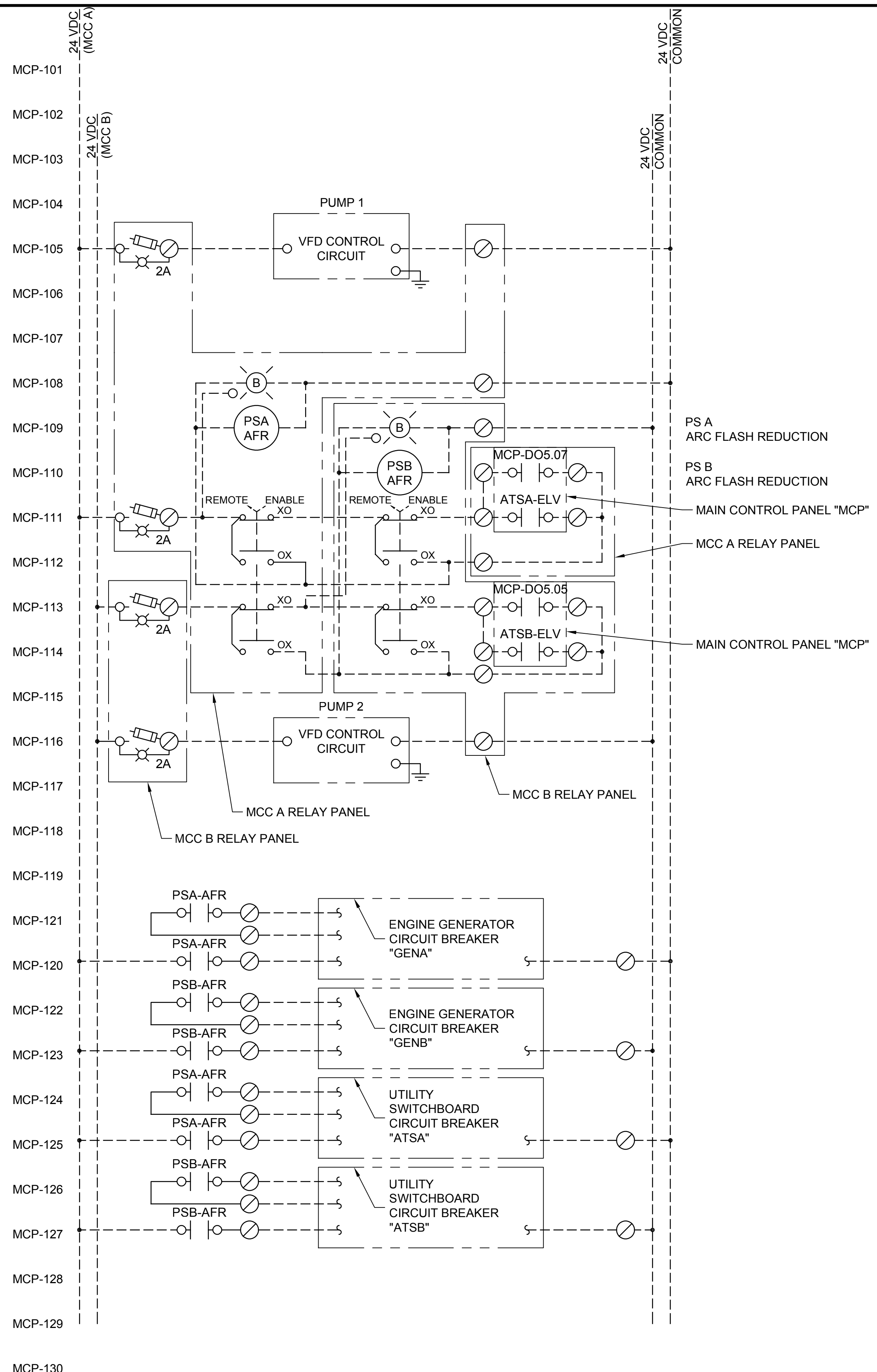

- MCP-101
- MCP-102
- MCP-103
- MCP-104
- MCP-105
- MCP-106
- MCP-107
- MCP-108
- MCP-109
- MCP-110
- MCP-111
- MCP-112
- MCP-113
- MCP-114
- MCP-115
- MCP-116
- MCP-117
- MCP-118
- MCP-119
- MCP-120
- MCP-121
- MCP-122
- MCP-123
- MCP-124
- MCP-125
- MCP-126
- MCP-127
- MCP-128
- MCP-129
- MCP-130
- MCP-131
- MCP-132
- MCP-133
- MCP-134
- MCP-135
- MCP-136
- MCP-137
- MCP-138
- MCP-139
- MCP-140
- MCP-141
- MCP-142
- MCP-143
- MCP-144
- MCP-145
- MCP-146
- MCP-147
- MCP-148
- MCP-149
- MCP-150
- MCP-151
- MCP-152
- MCP-153
- MCP-154
- MCP-155
- MCP-156
- MCP-157
- MCP-158
- MCP-159
- MCP-160

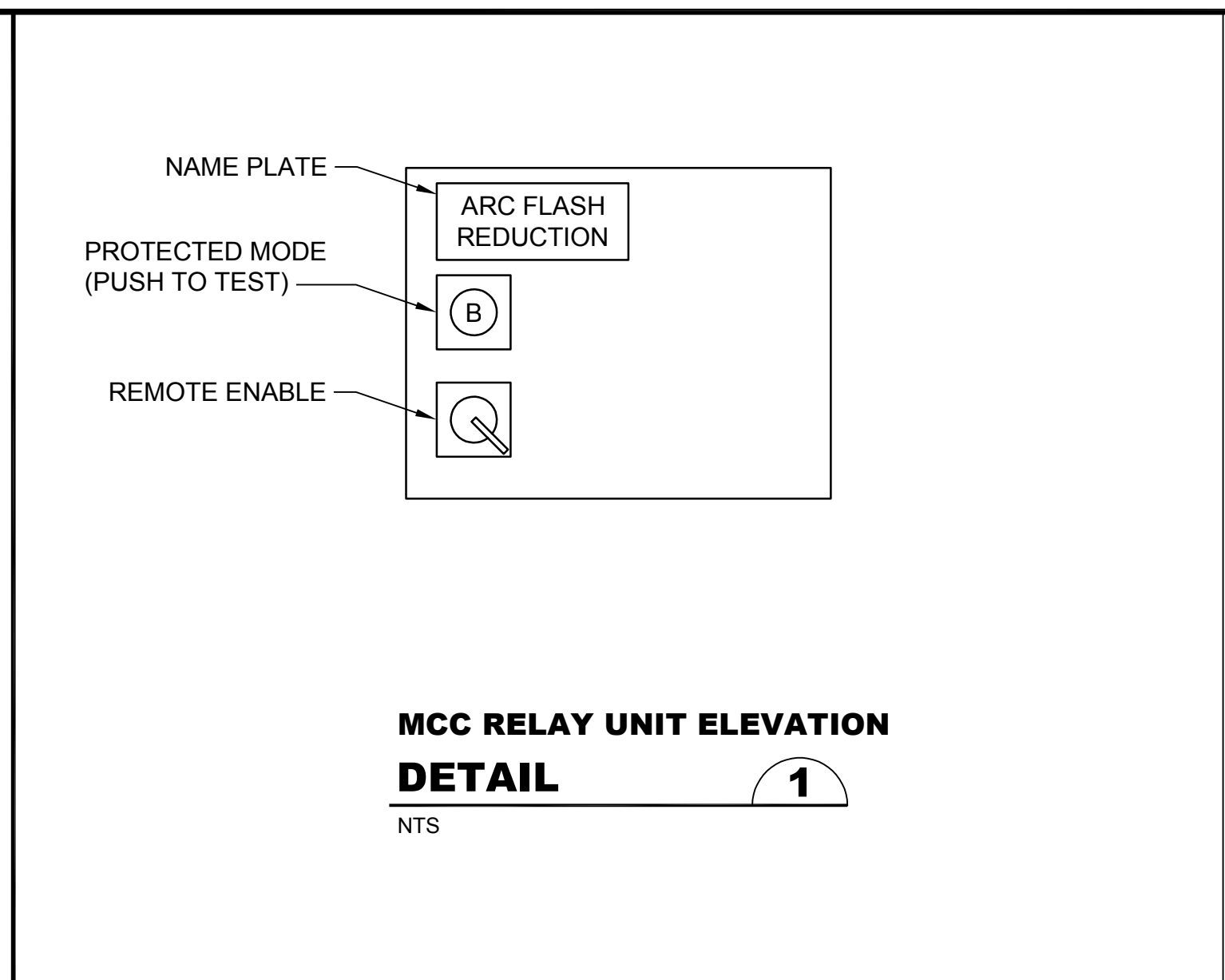

- NOTES:**
1. CONNECT TO 24VDC POWER SUPPLIES IN MCC A AND MCC B.
    - 1.1. POWER SUPPLY PS A IS LOCATED IN MCC A.
    - 1.2. POWER SUPPLY PS B IS LOCATED IN MCC B.
  2. ELEV - ATS CONNECT TO THE ELEVATOR "PRE-TRANSFER" SIGNAL.
  3. CONNECT TO CIRCUIT BREAKER'S ARC FLASH REDUCTION MODULE. ARRANGE CONTACTS FOR EITHER DRY CONTACT OR POWERED FROM MCC A OR MCC B 24VDC POWER SUPPLY.
    - a. ATS A (FROM UTILITY) FEEDER
    - b. ATS B (FROM UTILITY) FEEDER
    - c. ATS A (FROM GENERATOR) FEEDER
    - d. ATS B (FROM GENERATOR) FEEDER

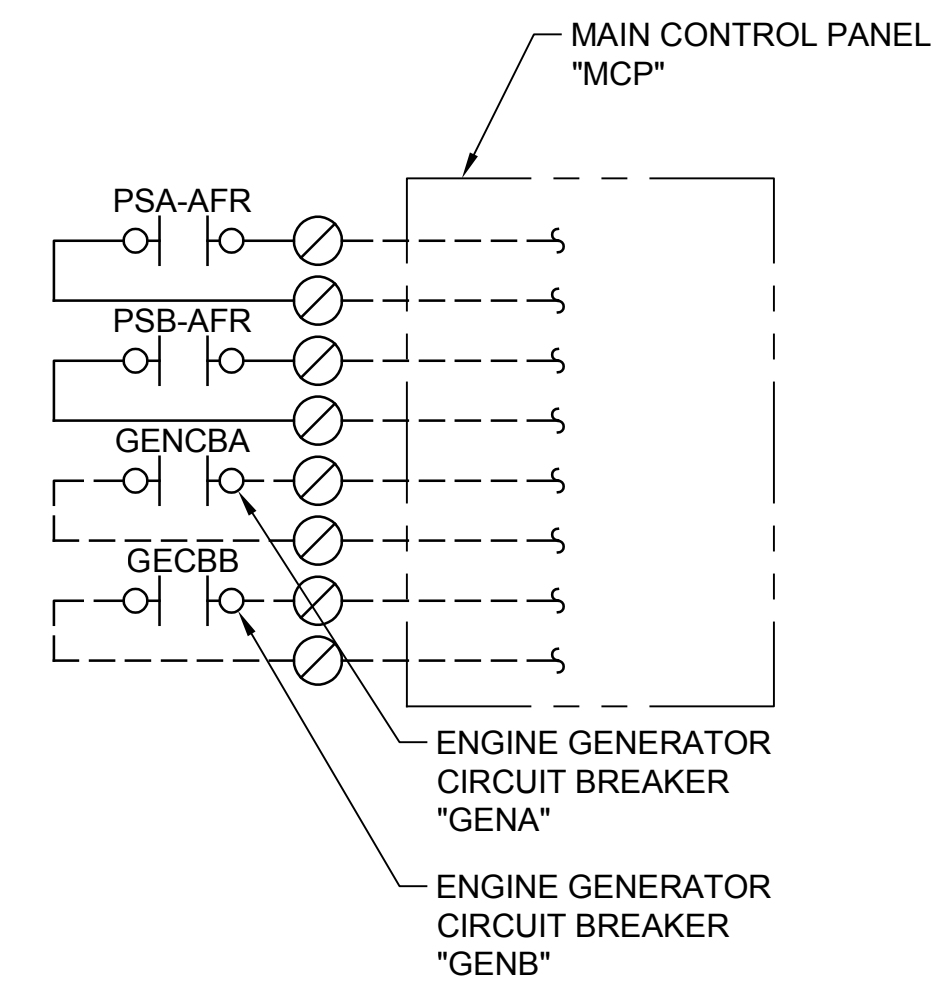

**Call 48 Hours  
Before You Dig**  
 1-800-424-5555  
 UNDERGROUND SERVICE

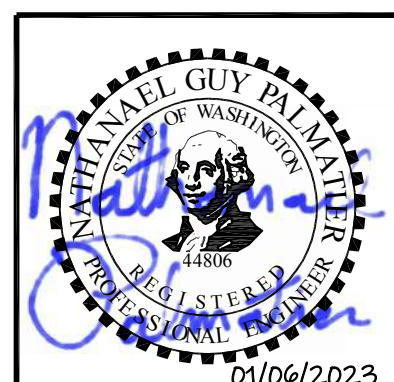

No.	Revision	Date	By	App'd
	ISSUED FOR BID	01-2023	TF	RAD

**bhc**  
 CONSULTANTS

**BHC Consultants, LLC**  
 1601 Fifth Avenue, Suite 500  
 Seattle, Washington 98101  
 206.505.3400  
 206.505.3406 (fax)  
 www.bhcconsultants.com

Designed: N. Palmatier, P.E.  
 Drawn: A. Bradley  
 Checked: R. Dorn, P.E.

Scale:  
 NTS  
 One Inch at Full Scale  
 If Not One Inch  
 Scale Accordingly



**Kitsap County Public Works**  
 614 Division Street, MS 26  
 Port Orchard, WA 98366

**SILVERDALE CONVEYANCE SYSTEM AND PUMP STATION 4 UPGRADES  
 SCHEDULE C**

**SCHEMATIC DIAGRAMS  
 6 OF 7**

Drawing: **E-15C**  
 Sheet: **101** of **117**  
 File: P21-10530\_E-15C  
 Date: January 2023

Path: S:\CAD\Kitsap County\21-10530 Silverdale Convey-PS 4 Uprg\Design\Drawings\21-10530\_E-16C\_Plot.dwg Plot date: Jan 06, 2023 09:33:13am CAD User: solsoe  
 Xref Filename: 21-10530\_TB | Palmatier | Dan | Fisher |

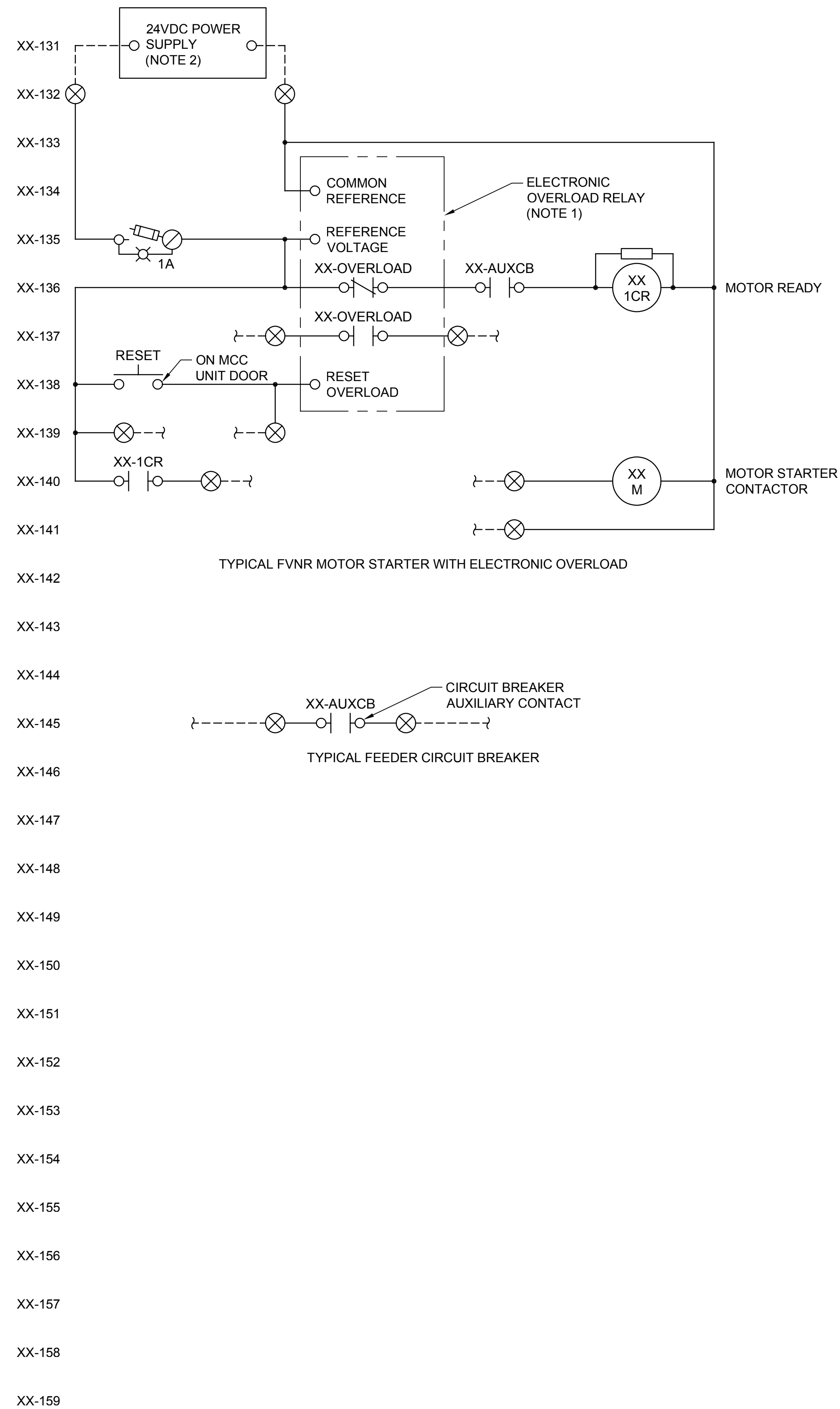
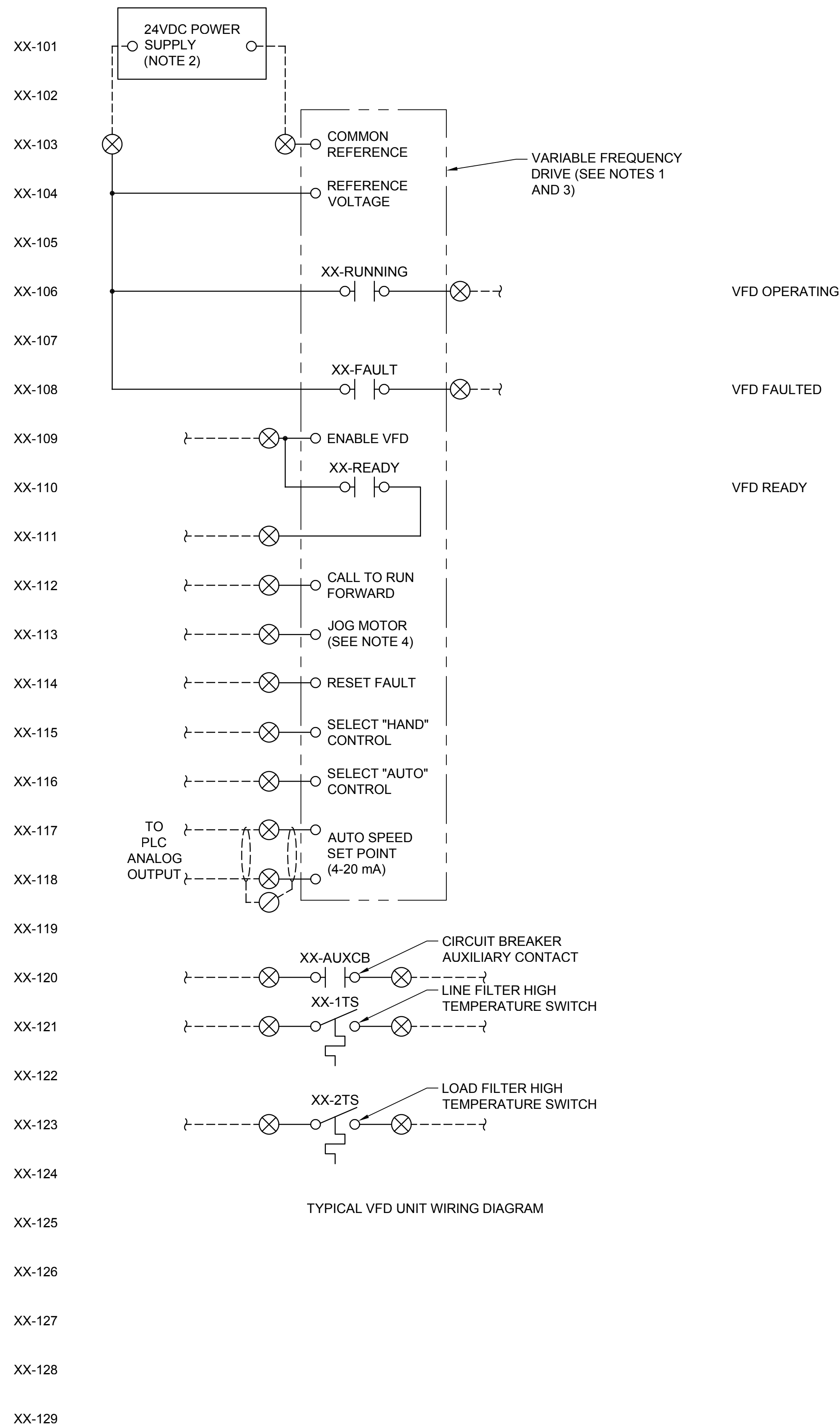

**NOTES:**

1. PROVIDE NETWORK COMMUNICATIONS MODULE (FOR FUTURE USE) WHICH MAKES AVAILABLE STATUS REGISTERS OVER AN EHTERNET NETWORK USING ROCKWELL AUTOMATION ETHERNET IP OR MODBUS TCP PROTOCOL.
2. COORDINATE THE CONTROL RELAY COILS TO MATCH THE VOLTAGE ACTUALLY PROVIDED.
3. PROVIDE MODULE TO ACCEPT EXTERNAL POWER FOR THE CONTROL FUNCTIONS OF THE VFD; THE EXTERNAL POWER SHALL NOT CHARGE THE FREQUENCY CONVERTER POWER BUS.
4. JOG MOTOR WILL OVERRIDE THE SELECTED SPEED SET POINT.
5. WIRING FOR SUBMERSIBLE WASTEWATER PUMPS WILL BE SIMILAR TO PUMP 1.
6. FIELD WIRING FROM THE MCC UNITS ROUTE TO THE BUILDING MAIN CONTROL PANEL.

No.	Revision	Date	By	App'd
		01-2023	TF	RAD
	ISSUED FOR BID			

**bhc**  
CONSULTANTS

**BHC Consultants, LLC**  
1601 Fifth Avenue, Suite 500  
Seattle, Washington 98101  
206.505.3400  
206.505.3406 (fax)  
www.bhcconsultants.com

Designed: N. Palmatier, P.E.  
 Drawn: N. Palmatier, P.E.  
 Checked: R. Dorn, P.E.

Scale:  
 NTS  
 One Inch at Full Scale  
 If Not One Inch Scale Accordingly



**Kitsap County Public Works**  
 614 Division Street, MS 26  
 Port Orchard, WA 98366

**SILVERDALE CONVEYANCE SYSTEM AND PUMP STATION 4 UPGRADES**  
 SCHEDULE C  
**SCHEMATIC DIAGRAMS**  
 7 OF 7

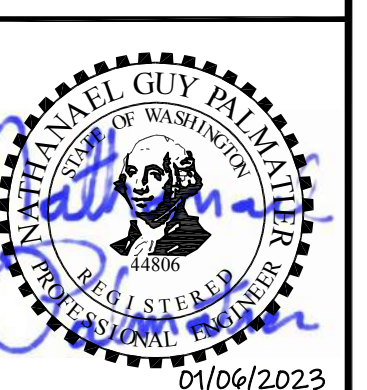

Drawing: **E-16C**  
 Sheet: **102** of **117**  
 File: P21-10530\_E-16C  
 Date: January 2023

**Call 48 Hours Before You Dig**  
 1-800-424-5555  
 UNDERGROUND SERVICE



Path: S:\Cad\Kitsap County\21-10530 Silverdale Convey-PS 4 Upgr\Design\Drawings\21-10530\_E-18C\_Plot.dwg Plot date: Jan 06, 2023 09:37:53am CAD User: soisce  
 Xref Filename: I:\21-10530\_TB\Palmatier\Drawings\Fisher1

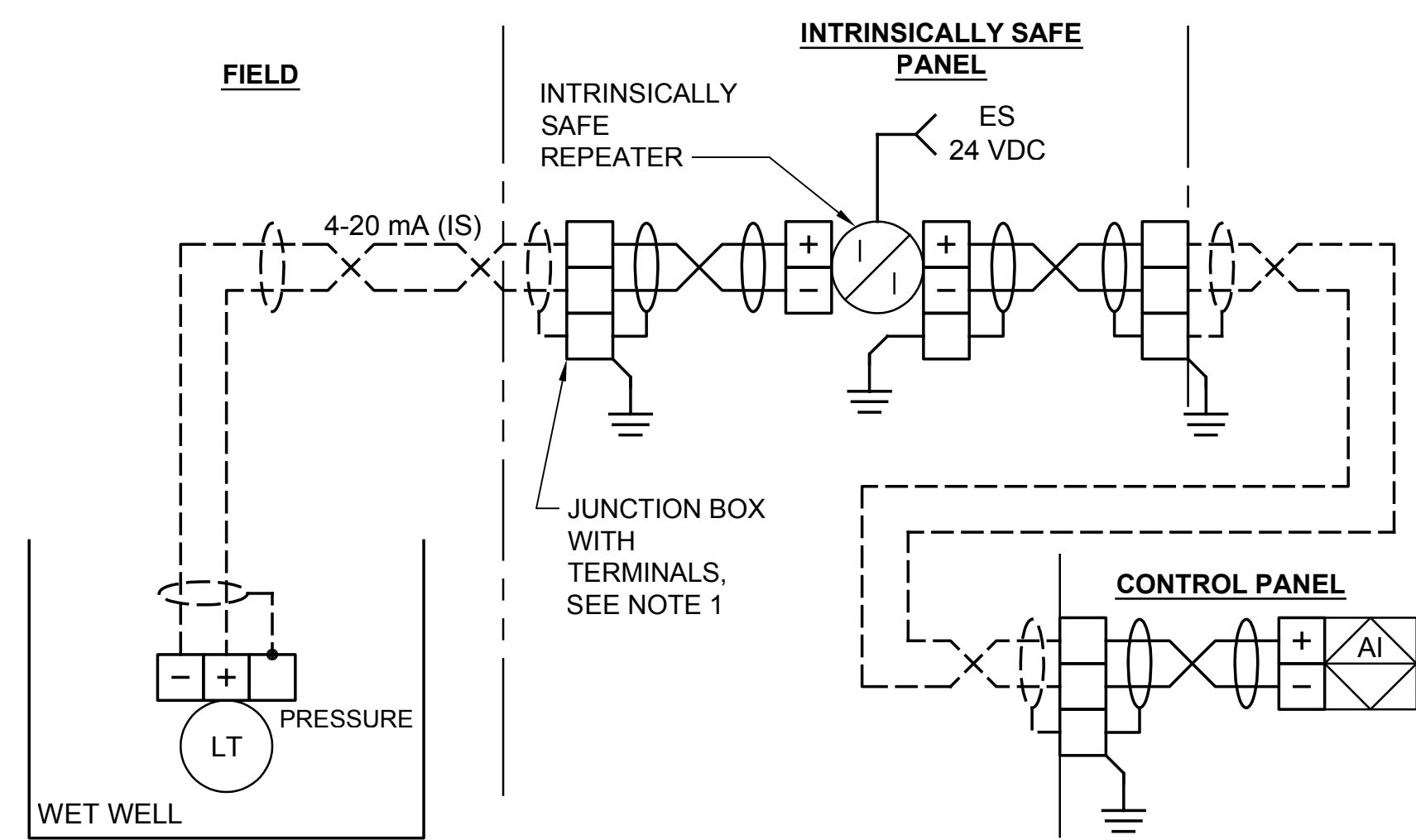

**ANALOG LOOP DIAGRAM  
SUBMERSIBLE LEVEL TRANSMITTER  
DETAIL**

1

NTS

**NOTE**

1. PROVIDE BREATHER BAG ASSEMBLY IN JUNCTION BOX.
2. INTRINSICALLY SAFE REPEATER LOCATED IN ISOLATOR PANEL AT PS19; SHOW INCOMING AND OUTGOING TERMINALS FOR SIGNALS

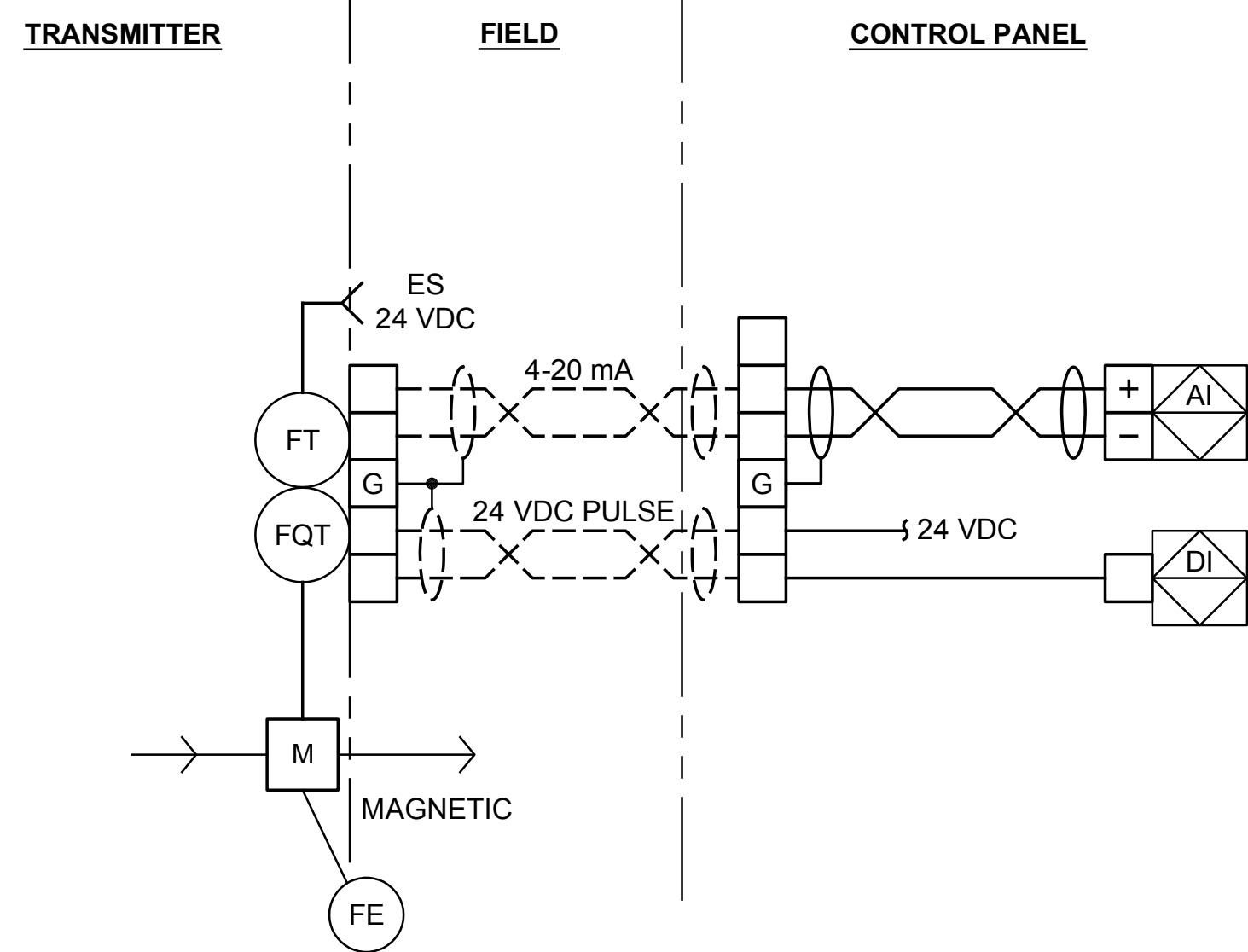

**ANALOG LOOP DIAGRAM FLOW METER  
WITH INTEGRAL TRANSMITTER  
DETAIL**

2

NTS

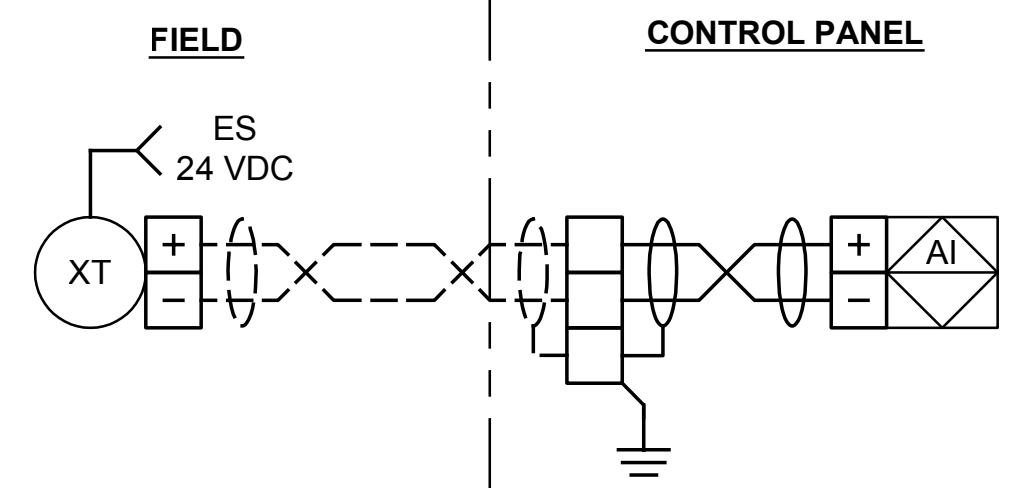

**ANALOG LOOP DIAGRAM  
GENERIC TRANSMITTER  
DETAIL**

3

NTS

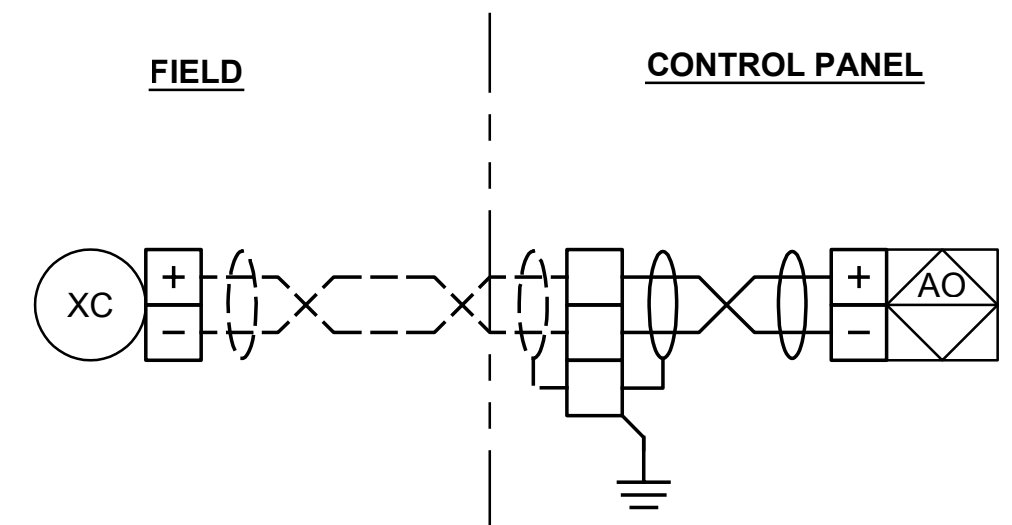

**ANALOG LOOP DIAGRAM  
GENERIC CONTROLLER  
DETAIL**

4

NTS

**Call 48 Hours  
Before You Dig**

**1-800-424-5555**

UNDERGROUND SERVICE

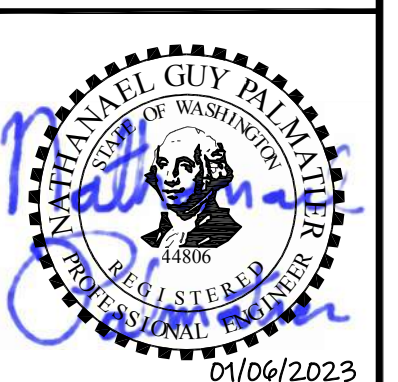

Drawing: **E-18C**  
 Sheet: **104** of **117**  
 File: P21-10530\_E-18C  
 Date: January 2023

No.	Revision	Date	By	App'd
	ISSUED FOR BID	01-2023	TF	RAD



**BHC Consultants, LLC**  
 1601 Fifth Avenue, Suite 500  
 Seattle, Washington 98101  
 206.505.3400  
 206.505.3406 (fax)  
 www.bhcconsultants.com

Designed: N. Palmatier, P.E.  
 Drawn: J. Lira  
 Checked: R. Dorn, P.E.

Scale:  
 NTS  
 One Inch at Full Scale  
 If Not One Inch  
 Scale Accordingly



**Kitsap County Public Works**  
 614 Division Street, MS 26  
 Port Orchard, WA 98366

**SILVERDALE CONVEYANCE SYSTEM AND PUMP STATION 4 UPGRADES  
SCHEDULE C**

**ANALOG LOOP DIAGRAMS**



Path: S:\CAD\Kitsap County\21-10530 Silverdale Convey-PS 4 Uprgr\Design\Drawings\21-10530\_E-19C\_Plot.dwg Plot date: Jan 06, 2023 09:40:26am CAD User: solisee  
Xref Filename: 21-10530\_TB | Palmatier | Dahn | Fisher |

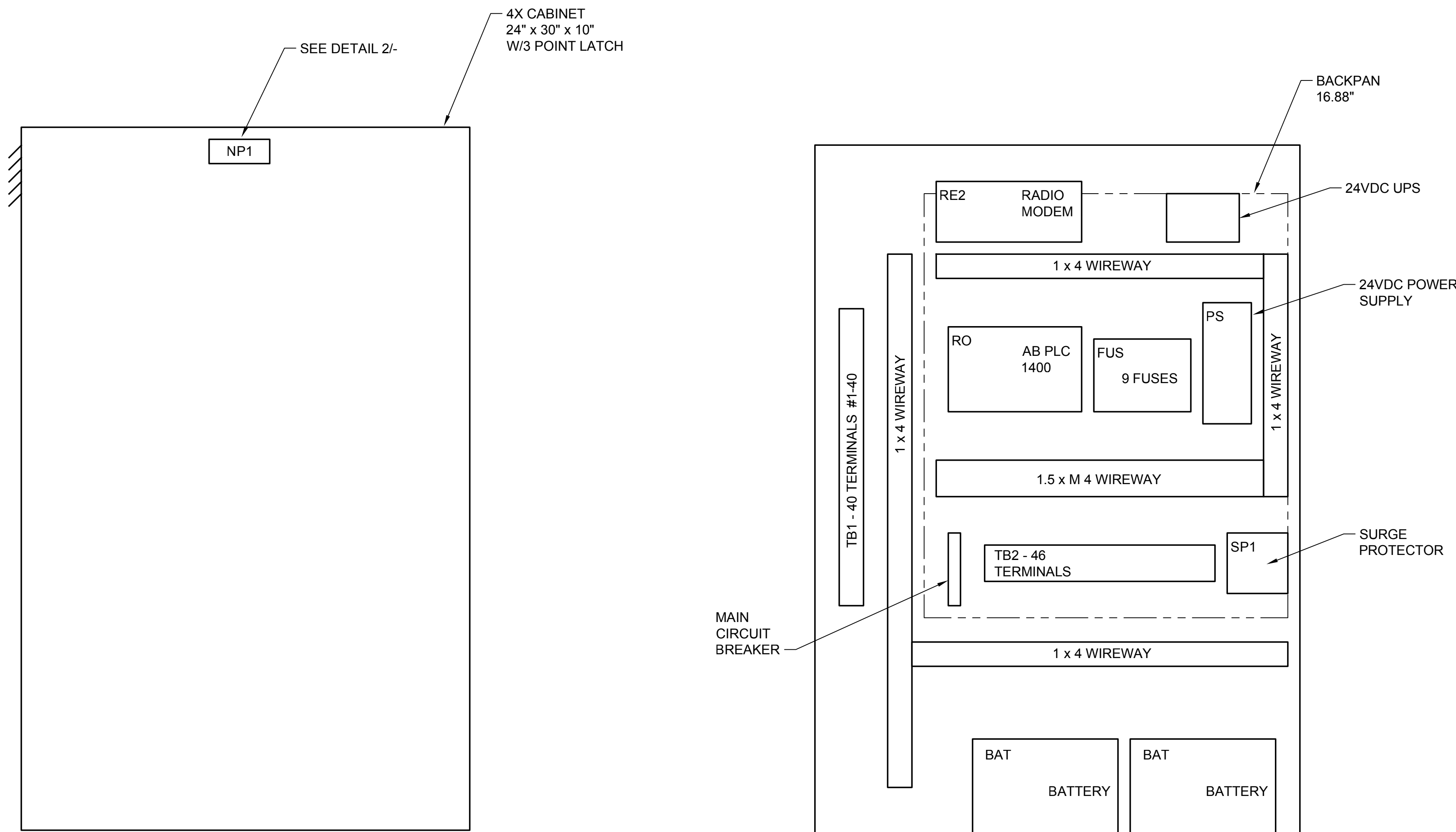

**EXTERNAL VIEW**

**INTERNAL VIEW**

**TELEMETRY PANEL**

**DETAIL**

1

NTS

**NOTES:**

- PUMP STATION #4 TELEMETRY CONTROL PANEL  
9606 BUCKLIN HILL ROAD.

**PUMP STATION #  
TELEMETRY CONTROL PANEL  
STREET ADDRESS**

**NAMEPLATE**

**DETAIL**

2

NTS

**NOTES:**

- THE TELEMETRY PANEL LAYOUT AND DEVICES AS SHOWN ON THE PLANS ARE INTENDED TO BE SPECIFIC IN THE DESIGN AND CONSTRUCTION SO AS TO BE IDENTICAL TO THE COUNTY'S STANDARD TELEMETRY PANEL. COORDINATE WITH THE OWNER FOR SPECIFIC DETAILS SUCH AS WIRE AND TERMINAL NUMBERING, BACKPAN LAYOUT, ETC.
- THE BACKPAN SIZE AND HOLE PATTERN/PLACEMENT SHALL BE COORDINATED WITH THE OWNER SO THAT BACKPANS CAN BE EXCHANGED WITH EXISTING PANELS.
- THE COUNTY WILL PROVIDE THE ACTUAL STREET ADDRESS TO THE SUCCESSFUL CONTRACTOR AFTER AWARD. USE THE ACTUAL STREET ADDRESS.
- THE FOLLOWING COMPONENTS ARE COUNTY STANDARD FOR TELEMETRY PANELS AND SHALL BE PROVIDED WITHOUT SUBSTITUTIONS.

**TELEMETRY PANEL MATERIALS - BOM**

TAG	SUBSTITUTION ALLOWED	DESCRIPTION	MANUFACTURER	PART NUMBER
RO	NO	MICROLOGIX 1400, 24VDC (20) DC INPUTS (6) DC OUTPUTS, (6) RELAY OUTPUTS (4) ANALOG INPUTS (2) ANALOG INPUTS	ALLEN BRADLEY	1766-L32BXBA
RE1	NO	RADIO/MODEM 136-174 MHZ, 10-30VDC, 1.5A 1 WATT @ FREQUENCY	CALAMP VIPER SC-100 IP	140-5018-502 250-5099-005
CBL1		CAT 5 ETHERNET CABLE		
CBL2		COAX ANTENNA CABLE		
SP1		SURGE PROTECTOR		AS SPECIFIED
BAT	NO	UPS BATTERIES	WERKER	WKA12-12F2
PS	NO	90W 24VDC POWER SUPPLY	IDEC	IDECPS5R-VE24
FUS		FUSED DISCONNECTS WITH BLOWN FUSE INDICATORS		AS SPECIFIED
LA	NO	RADIO LIGHTNING ARRESTOR	POLY PHASER	DT-NFF
UPS	NO	BATTERY VOLTAGE UPS RELAY	TRANSTRONICS	BVUPS24PFA
ANT	NO	RADIO ANTENNA	KATHERIEN	YA7-166
RE2	NO	CELL ETHERNET RADIO MODEM	CRADLEPOINT	IBR900-600M-NA
REC		RADIO ENCLOSURE WITH 110VAC OUTLET AND HEATER	L-COMM	NB141207-100-UL
EMCL	NO	TELEMETRY PANEL ENCLOSURE AND SUB-PANEL	STAHL	J3024HPL

**Call 48 Hours  
Before You Dig**

**1-800-424-5555**  
UNDERGROUND SERVICE

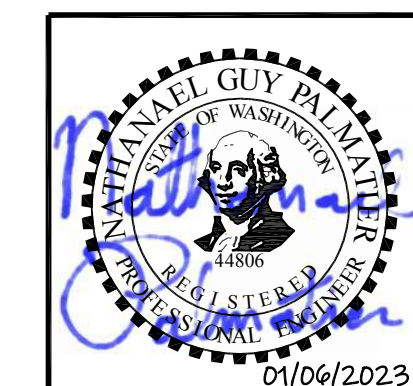

No.	Revision	Date	By	App'd
	ISSUED FOR BID	01-2023	TF	RAD



**BHC Consultants, LLC**  
1601 Fifth Avenue, Suite 500  
Seattle, Washington 98101  
206.505.3400  
206.505.3406 (fax)  
www.bhcconsultants.com

Designed: N. Palmatier, P.E.

Drawn: J. Lira

Checked: R. Dorn, P.E.

Scale:

NTS

One Inch at Full Scale  
If Not One Inch  
Scale Accordingly



**Kitsap County Public Works**

614 Division Street, MS 26  
Port Orchard, WA 98366

**SILVERDALE CONVEYANCE SYSTEM AND PUMP STATION 4 UPGRADES  
SCHEDULE C**

**TELEMETRY CONTROL PANEL  
ELEVATIONS**

Drawing: **E-19C**

Sheet: **105** of **117**

File: P21-10530\_E-19C

Date: January 2023

Path: S:\Cadd\Kitsap County\21-10530 Silverdale Convey-PS 4 Uprgr\Design\Drawings\21-10530\_E-20C Plot date: Jan 06, 2023 09:42:37am CAD User: solsoe  
 Xref Filename: | X21-10530\_TB | Palmatier | X21-10530\_Prelim | Data | Fisher |

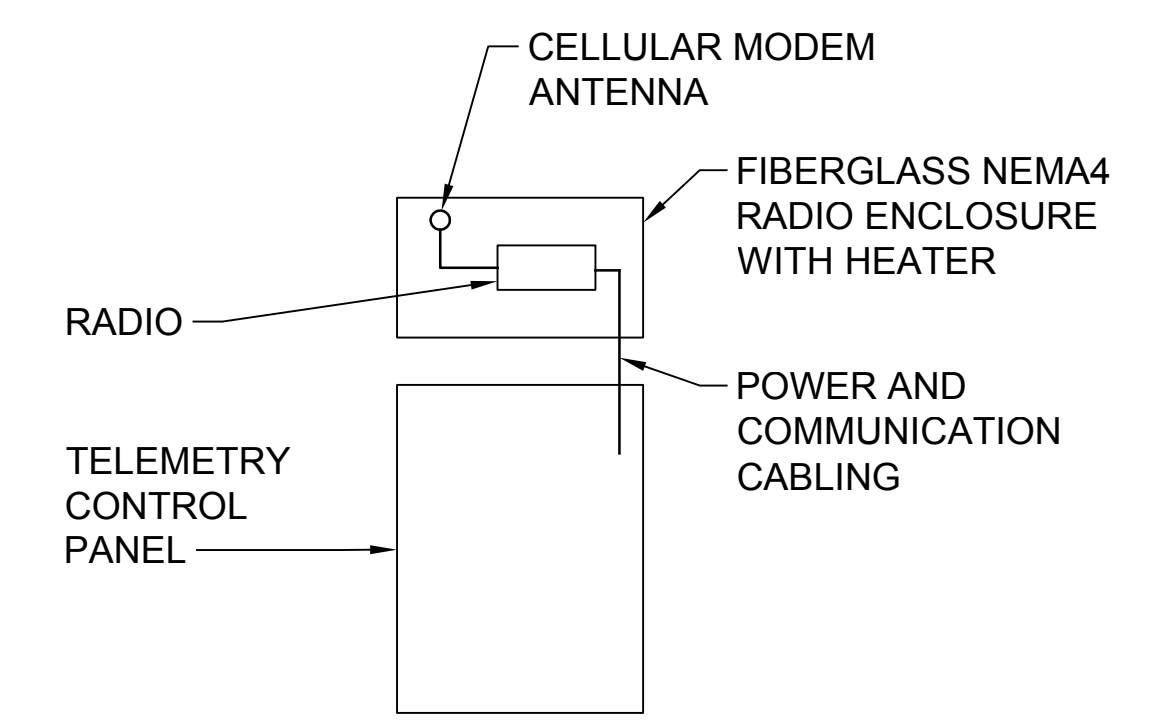
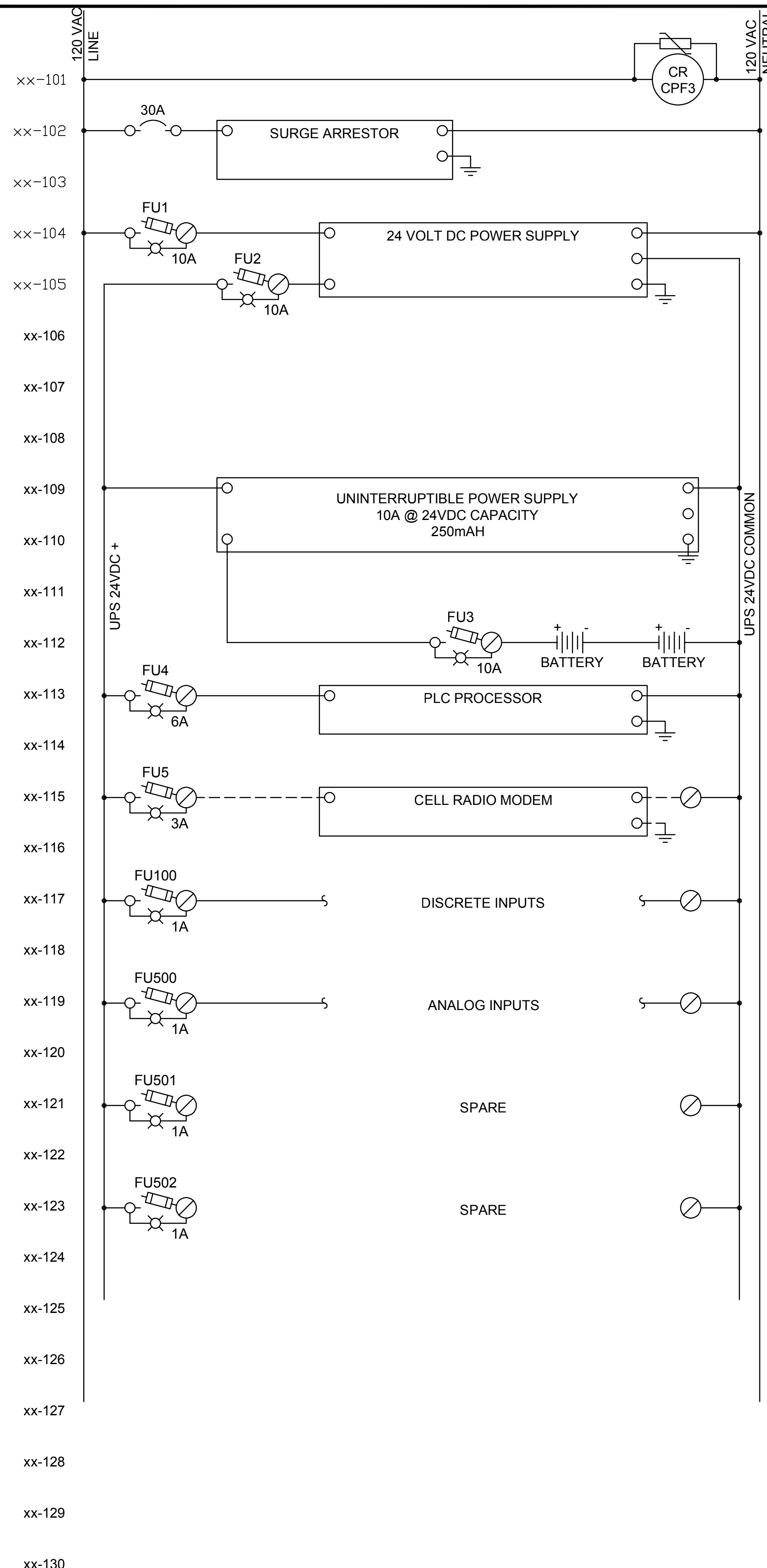

**ANTENNA RISER  
 DETAIL 1**  
 NTS

- NOTES:**
- \* PROVIDE CIRCUIT INDEX OR COPY OF POWER CIRCUIT WIRING DIAGRAM FOR ALL DISTRIBUTION BREAKERS AND DC DISTRIBUTION FUSES - LAMINATE AND MOUNT ON INSIDE CABINET DOOR.
  - \*\* PROVIDE ALL POWER FAIL AS MONITORING CIRCUITS. NORMALLY OPEN CONTACTS THAT ARE HELD CLOSED AND OPEN WHEN POWER FAILS.
  - \*\*\* PROVIDE (FUTURE POWER FAIL ALARM OUTPUTS) TO BE A NORMALLY ENERGIZED RELAY THAT WILL DE-ENERGIZE FOR ANY COMMON ALARM CONDITION SO THAT TELEMETRY CONTACT INPUT WILL BE NORMALLY CLOSED AND OPEN ON ALARM CONDITION.

**Call 48 Hours  
 Before You Dig**  
 1-800-424-5555  
 UNDERGROUND SERVICE

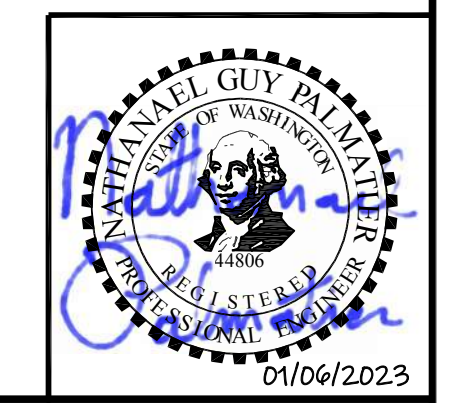

No.	Revision	Date	By	App'd
	ISSUED FOR BID	01-2023	TF	RAD

**bhc**  
 CONSULTANTS

**BHC Consultants, LLC**  
 1601 Fifth Avenue, Suite 500  
 Seattle, Washington 98101  
 206.505.3400  
 206.505.3406 (fax)  
 www.bhcconsultants.com

Designed: N. Palmatier, P.E.  
 Drawn: J. Lira  
 Checked: R. Dorn, P.E.

Scale:  
 NTS  
 One Inch at Full Scale  
 If Not One Inch  
 Scale Accordingly



**Kitsap County Public Works**  
 614 Division Street, MS 26  
 Port Orchard, WA 98366

**SILVERDALE CONVEYANCE SYSTEM AND PUMP STATION 4 UPGRADES  
 SCHEDULE C**

**TELEMETRY CONTROL PANEL  
 SCHEMATIC DIAGRAM**

Drawing: **E-20C**  
 Sheet: **106** of **117**  
 File: P21-10530\_E-20C  
 Date: January 2023

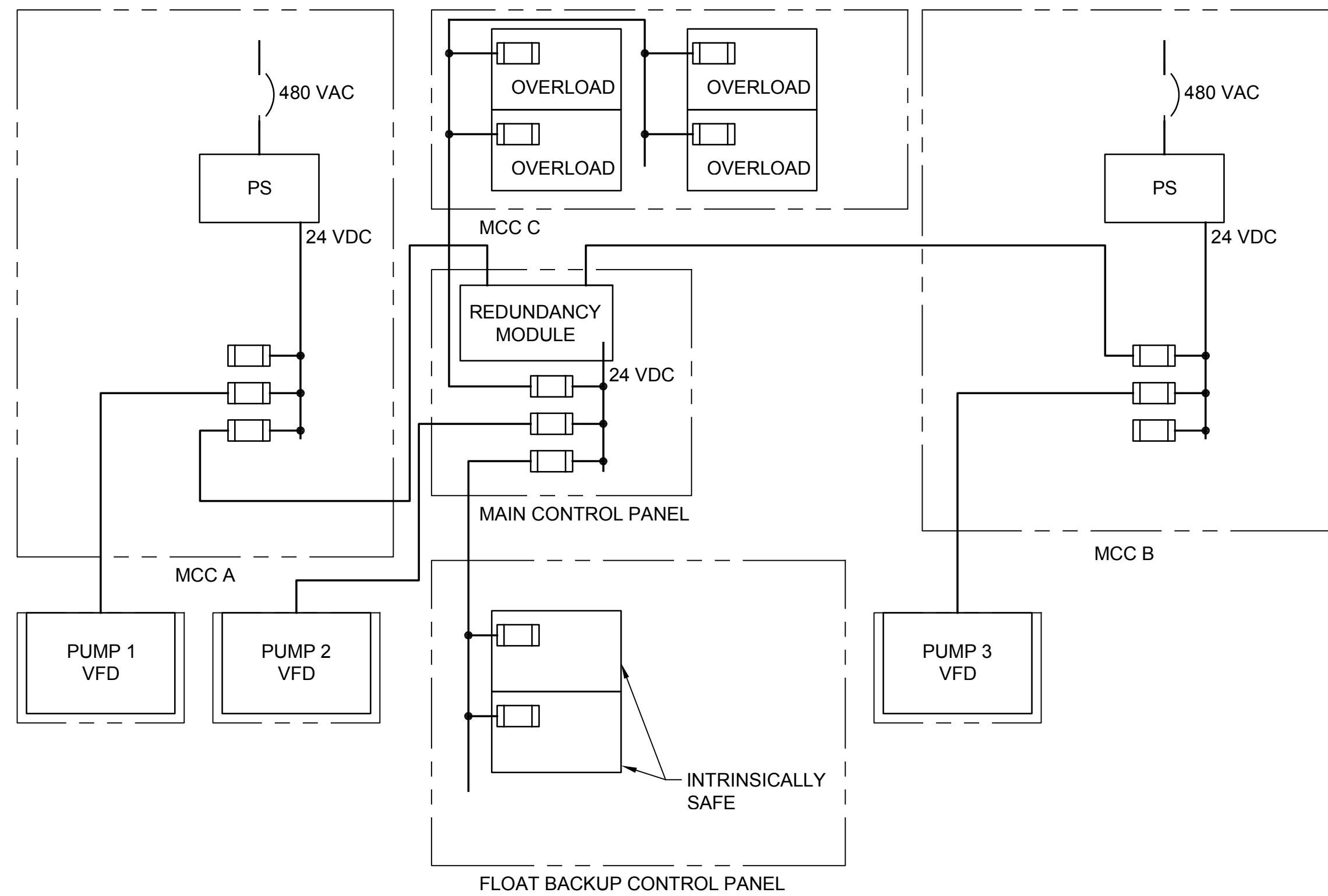

**CONTROL POWER RISER**  
**DETAIL**  
NTS

1

IP ADDRESS LIST	
DESCRIPTION	IP ADDRESS
DEFAULT GATEWAY	192.168.204.254
SUBNET MASK	255.255.255.0
MODEM (LAN)	192.168.204.254
MODEM (WAN)	TBD
PROGRAMMABLE LOGIC CONTROLLER	192.168.204.14
OPERATOR INTEFACE	192.168.204.13
FLOW METER	192.168.204.17
ATS A	192.168.204.98
ATS B	192.168.204.99
PUMP 1 VFD	192.168.204.33
PUMP 2 VFD	192.168.204.34
PUMP 3 VFD	192.168.204.35
OVERLOAD	192.168.204.65
OVERLOAD	192.168.204.66
OVERLOAD	192.168.204.67
OVERLOAD	192.168.204.68

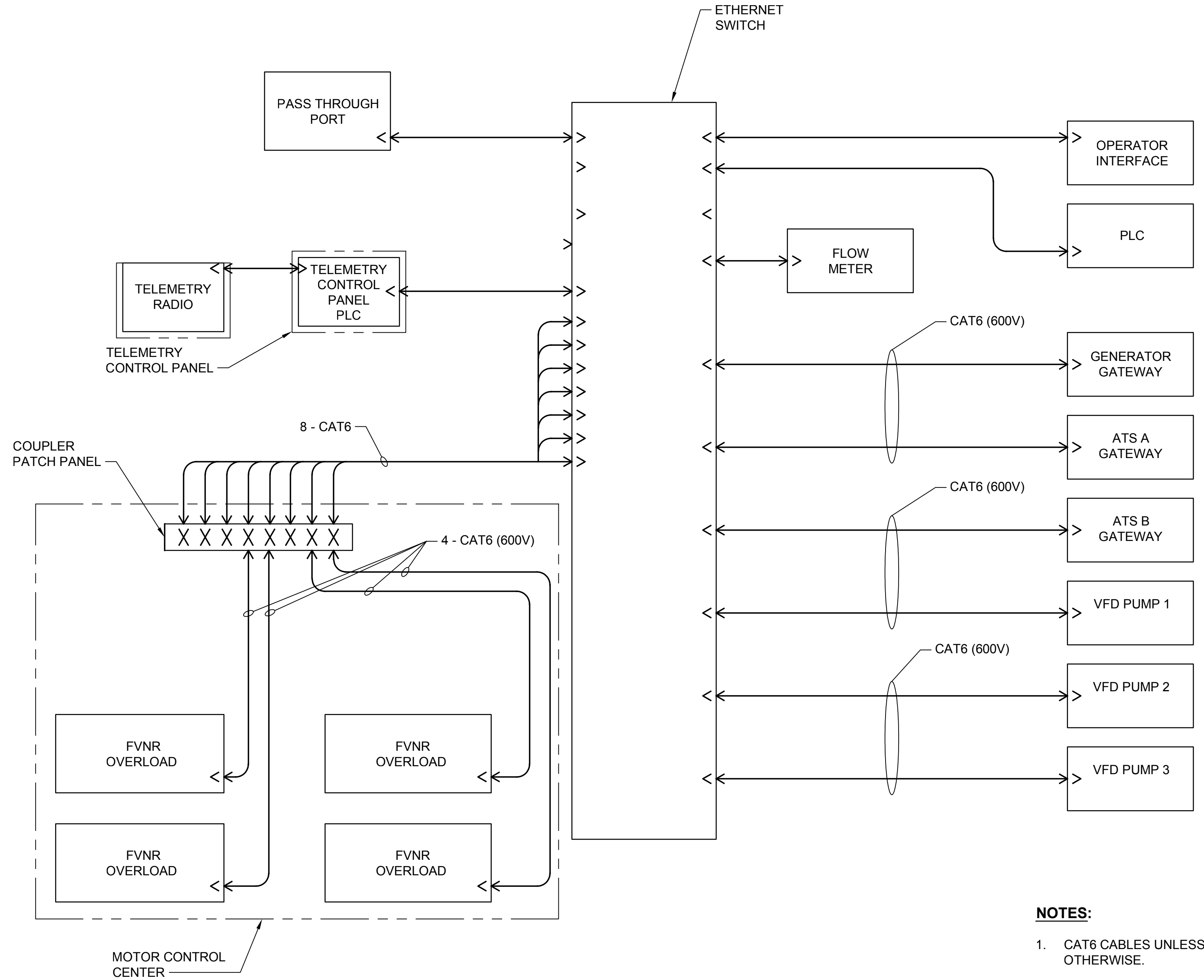

**ETHERNET COMMUNICATIONS RISER DIAGRAM**  
**DETAIL**  
NTS

2

- NOTES:**
- CAT6 CABLES UNLESS NOTED OTHERWISE.

**Call 48 Hours Before You Dig**  
1-800-424-5555  
UNDERGROUND SERVICE

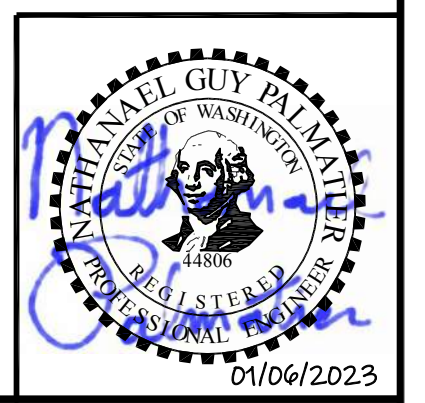

Path: S:\Cad\Kitsap County\21-10530 Silverdale Conveyance-PS 4 Uprgt\Design\Drawings\21-10530\_E-21C.dwg Plot date: Jan 06, 2023 09:45:21 am CAD User: soisce  
Xref Filename: 21-10530\_TB | Palmiter | 21-10530\_Prelim | Dahn | Fisher

No.	Revision	Date	By	App'd
	ISSUED FOR BID	01-2023	TF	RAD

**bhc** CONSULTANTS  
BHC Consultants, LLC  
1601 Fifth Avenue, Suite 500  
Seattle, Washington 98101  
206.505.3400  
206.505.3406 (fax)  
www.bhcconsultants.com

Designed: N. Palmiter, P.E.  
Drawn: G. Castillo  
Checked: R. Dorn, P.E.

Scale:  
NTS  
One Inch at Full Scale  
If Not One Inch Scale Accordingly



**Kitsap County Public Works**  
614 Division Street, MS 26  
Port Orchard, WA 98366

**SILVERDALE CONVEYANCE SYSTEM AND PUMP STATION 4 UPGRADES SCHEDULE C**

**COMMUNICATIONS RISER**

Drawing: **E-21C**  
Sheet: **107** of **117**  
File: P21-10530\_E-21C  
Date: January 2023

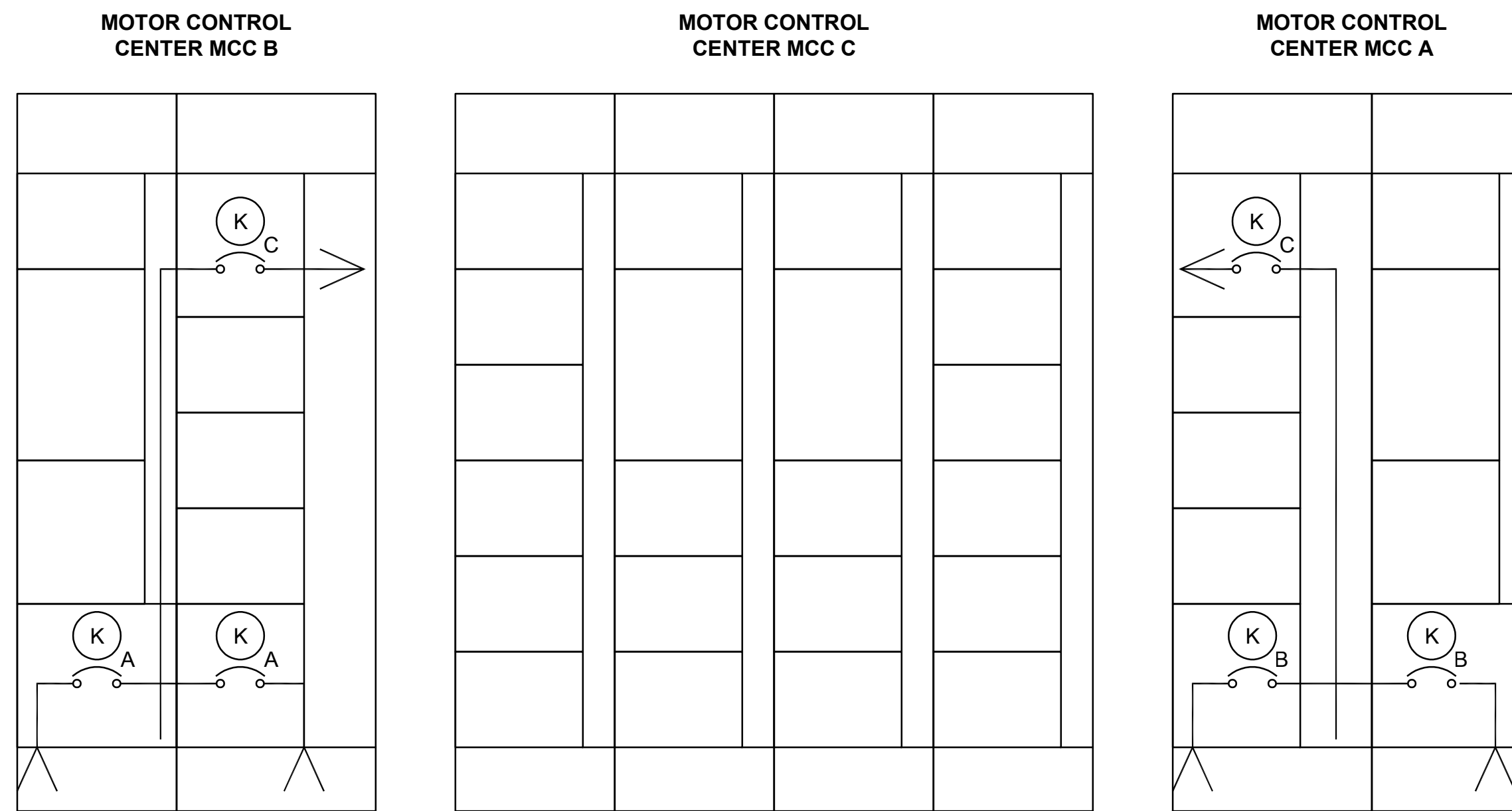

**MIMIC BUS  
ELEVATION** **A**  
SCALE: 3/4" = 1'-0"

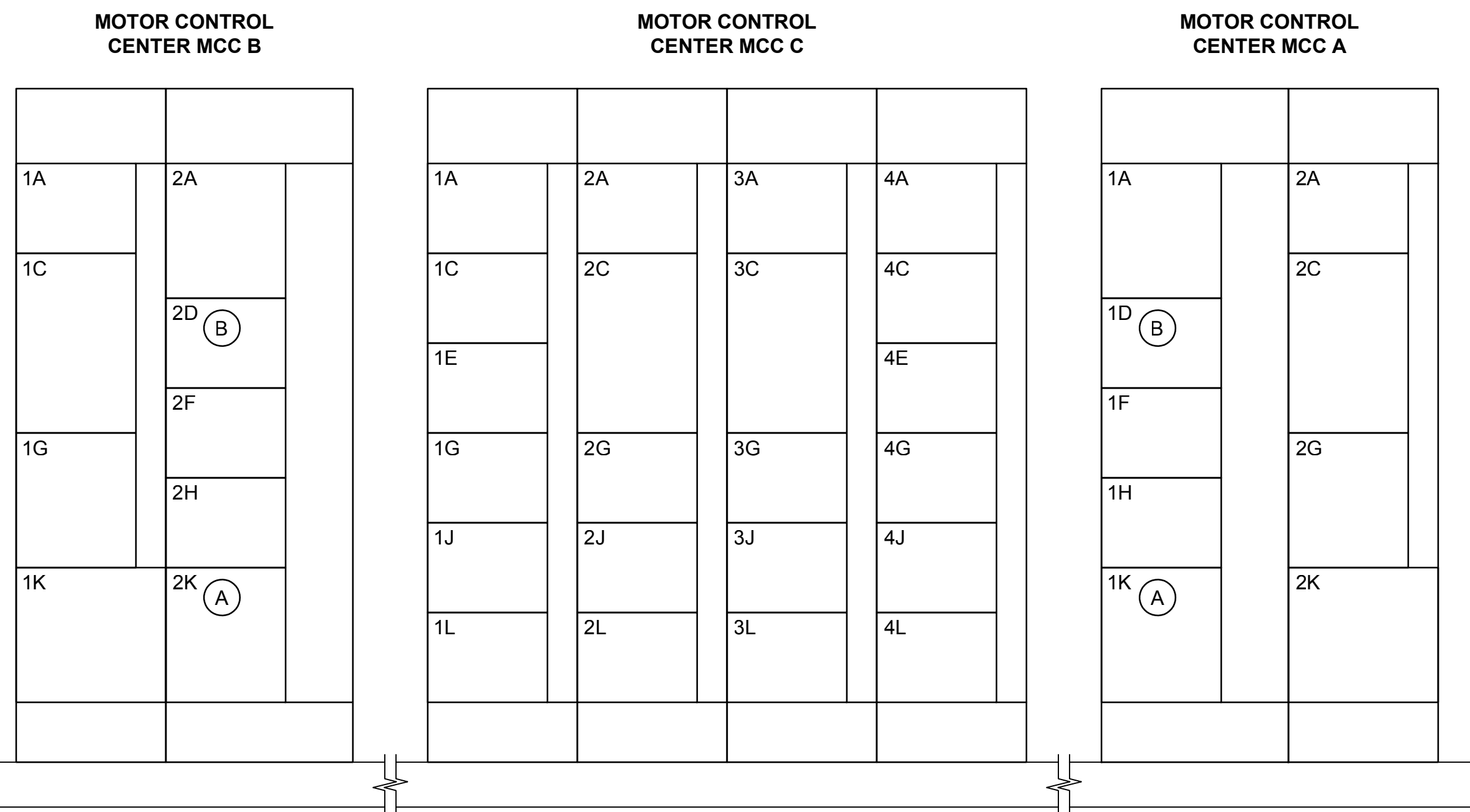

HOUSEKEEPING PAD,  
SEE STRUCTURAL DWGS

**MOTOR CONTROL CENTER  
ELEVATION** **B**  
SCALE: 3/4" = 1'-0"

**CONSTRUCTION NOTES:**

- (A)** ROLL-UP ENGINE GENERATOR INLET CIRCUIT BREAKER.
- (B)** ARC FLASH REDUCTION RELAY PANEL. PER DETAIL 1/E-12C.

MCC ELEVATION				
MCC A	2	A		
MCC A	2	C	PUMP 1 VFD	BRANCH
MCC A	2	G	24VDC POWER SUPPLY	MCC A
MCC A	2	K	MAIN CIRCUIT BREAKER	KIRK KEY A
MCC A	1	A	MCC C BRANCH	KIRK KEY C
MCC A	1	D	ARC FLASH REDUCTION	
MCC A	1	F		
MCC A	1	H		
MCC A	1	K	MAIN CIRCUIT BREAKER	KIRK KEY A
MCC C	1	A	MAIN LUGS ONLY	FROM MCC A
MCC C	1	C	2HP SPARE STARTER	
MCC C	1	E	SPARE CIRCUIT BREAKER	125A
MCC C	1	G	1HP SPARE STARTER	
MCC C	1	J	TRANSFORMER "TLA"	
MCC C	1	L		
MCC C	2	A		
MCC C	2	C	PUMP 2 VFD	BRANCH
MCC C	2	G	SPARE CIRCUIT BREAKER	125A
MCC C	2	J		
MCC C	2	L		
MCC C	3	A		
MCC C	3	C	SPARE VFD	BRANCH
MCC C	3	G	SUMP PUMP	
MCC C	3	J	2HP SPARE STARTER	
MCC C	3	L		
MCC C	4	A	MAIN LUGS ONLY	FROM MCC B
MCC C	4	C		
MCC C	4	E		
MCC C	4	G		
MCC C	4	J		
MCC C	4	L		
MCC B	2	A	MCC BRANCH	KIRK KEY C
MCC B	2	D	ARC FLASH REDUCTION	
MCC B	2	F		
MCC B	2	H		
MCC B	2	K	MAIN CIRCUIT BREAKER	KIRK KEY B
MCC B	1	A		
MCC B	1	C	PUMP 3 VFD	BRANCH
MCC B	1	G	24VDC POWER SUPPLY	MCC A
MCC B	1	K	MAIN CIRCUIT BREAKER	KIRK KEY B

**Call 48 Hours  
Before You Dig**

**1-800-424-5555**  
UNDERGROUND SERVICE

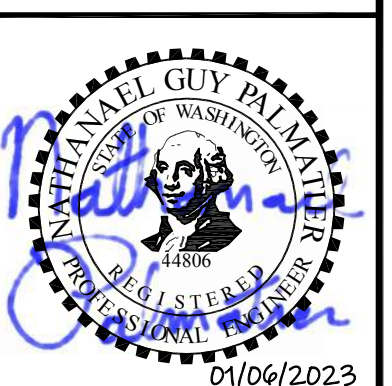

Path: S:\CAD\Kitsap County\21-10530 Silverdale Convey-PS 4 Uprgr\Design\Drawings\21-10530\_E-22C\_Plot.dwg Plot date: Jan 06, 2023 09:47:30am CAD User: solsoe  
Xref Filename: 21-10530\_TB | Palmatier | Datt | Fisher |

No.	Revision	Date	By	App'd
	ISSUED FOR BID	01-2023	TF	RAD



**BHC Consultants, LLC**  
1601 Fifth Avenue, Suite 500  
Seattle, Washington 98101  
206.505.3400  
206.505.3406 (fax)  
www.bhcconsultants.com

Designed: N. Palmatier, P.E.  
Drawn: A. Bradley  
Checked: R. Dorn, P.E.

Scale:  
As Shown  
One Inch at Full Scale  
If Not One Inch Scale Accordingly



**Kitsap County Public Works**  
614 Division Street, MS 26  
Port Orchard, WA 98366

**SILVERDALE CONVEYANCE SYSTEM AND PUMP STATION 4 UPGRADES  
SCHEDULE C**  
  
**MCC ELEVATIONS**

Drawing: **E-22C**  
Sheet: **108** of **117**  
File: P21-10530\_E-22C  
Date: January 2023

Path: S:\Cadd\Kitsap County\21-10530 Silverdale Convey-PS 4 Uprgt\Design\Drawings\21-10530\_E-23C.dwg Plot date: Jan 06, 2023 09:49:23am CAD User: soisce.  
 Xref Filename: 1\21-10530\_TB | Palmatier | Datt | Fisher |

SWITCHBOARD SCHEDULE				
SERVICE	1	A		
SERVICE	1	B	ATS A / MCC A	BRANCH
SERVICE	2	A	SURGE PROTECTIVE DEVICE	SPD
SERVICE	2	B	ATS B / MCC B	BRANCH
SERVICE	3		EUSERC METER	

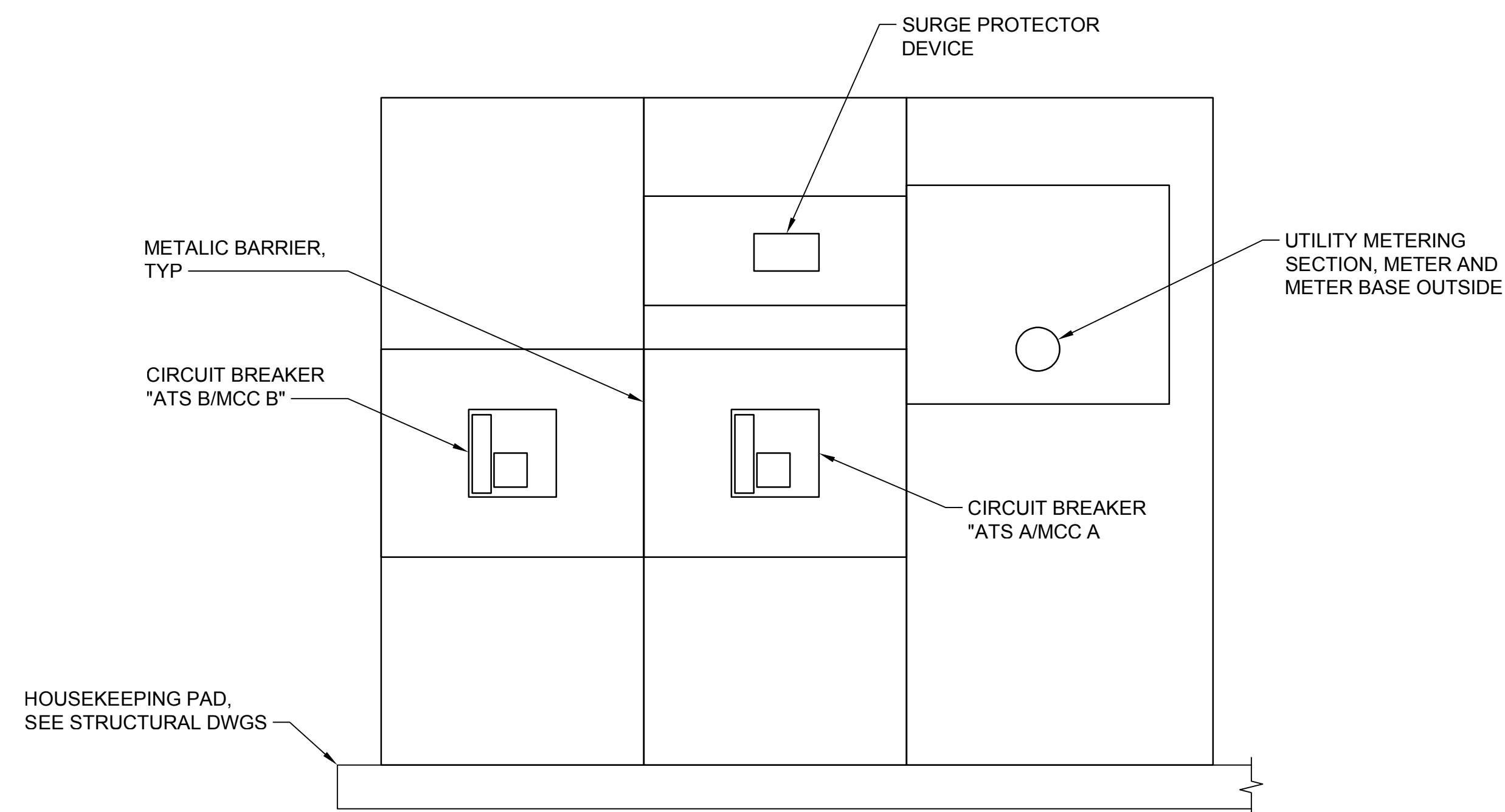

**UTILITY SWITCHBOARD**  
**ELEVATION** A  
 NTS

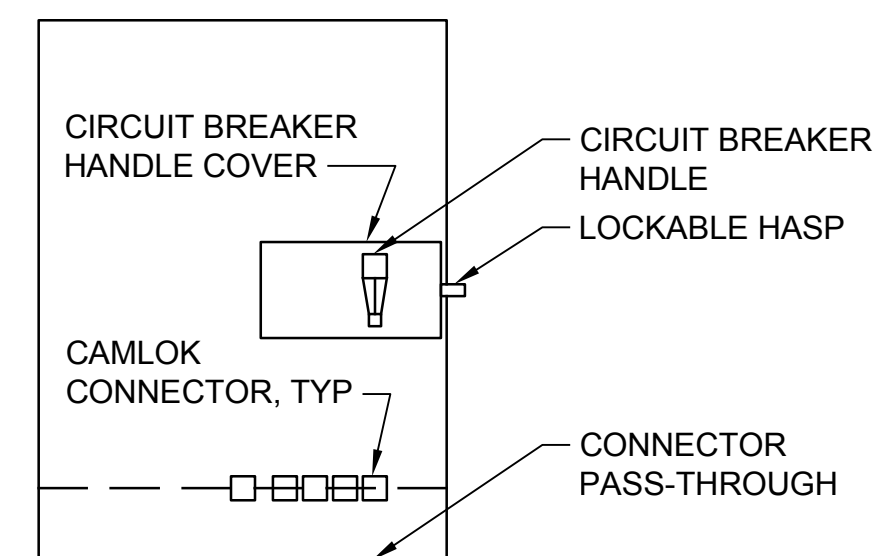

**GENERATOR INLET**  
**RECEPTACLE**  
**ELEVATION** B  
 NTS

**Call 48 Hours**  
**Before You Dig**  
 1-800-424-5555  
 UNDERGROUND SERVICE

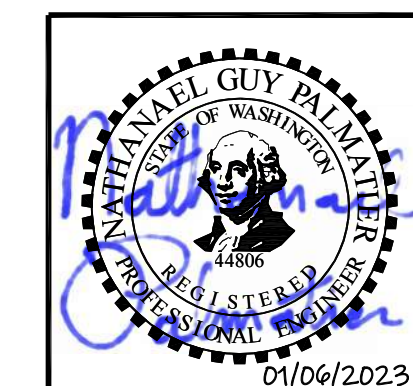

No.	Revision	Date	By	App'd
	ISSUED FOR BID	01-2023	TF	RAD

**bhc**  
**CONSULTANTS**  
**BHC Consultants, LLC**  
 1601 Fifth Avenue, Suite 500  
 Seattle, Washington 98101  
 206.505.3400  
 206.505.3406 (fax)  
 www.bhcconsultants.com

Designed: N. Palmatier, P.E.  
 Drawn: A. Bradley  
 Checked: R. Dorn, P.E.

Scale:  
 NTS  
 One Inch at Full Scale  
 If Not One Inch  
 Scale Accordingly



**Kitsap County Public Works**  
 614 Division Street, MS 26  
 Port Orchard, WA 98366

**SILVERDALE CONVEYANCE SYSTEM AND PUMP STATION 4 UPGRADES**  
**SCHEDULE C**  
**SWITCHBOARD ELEVATIONS**

Drawing: **E-23C**  
 Sheet: **109** of **117**  
 File: P21-10530\_E-23C  
 Date: January 2023

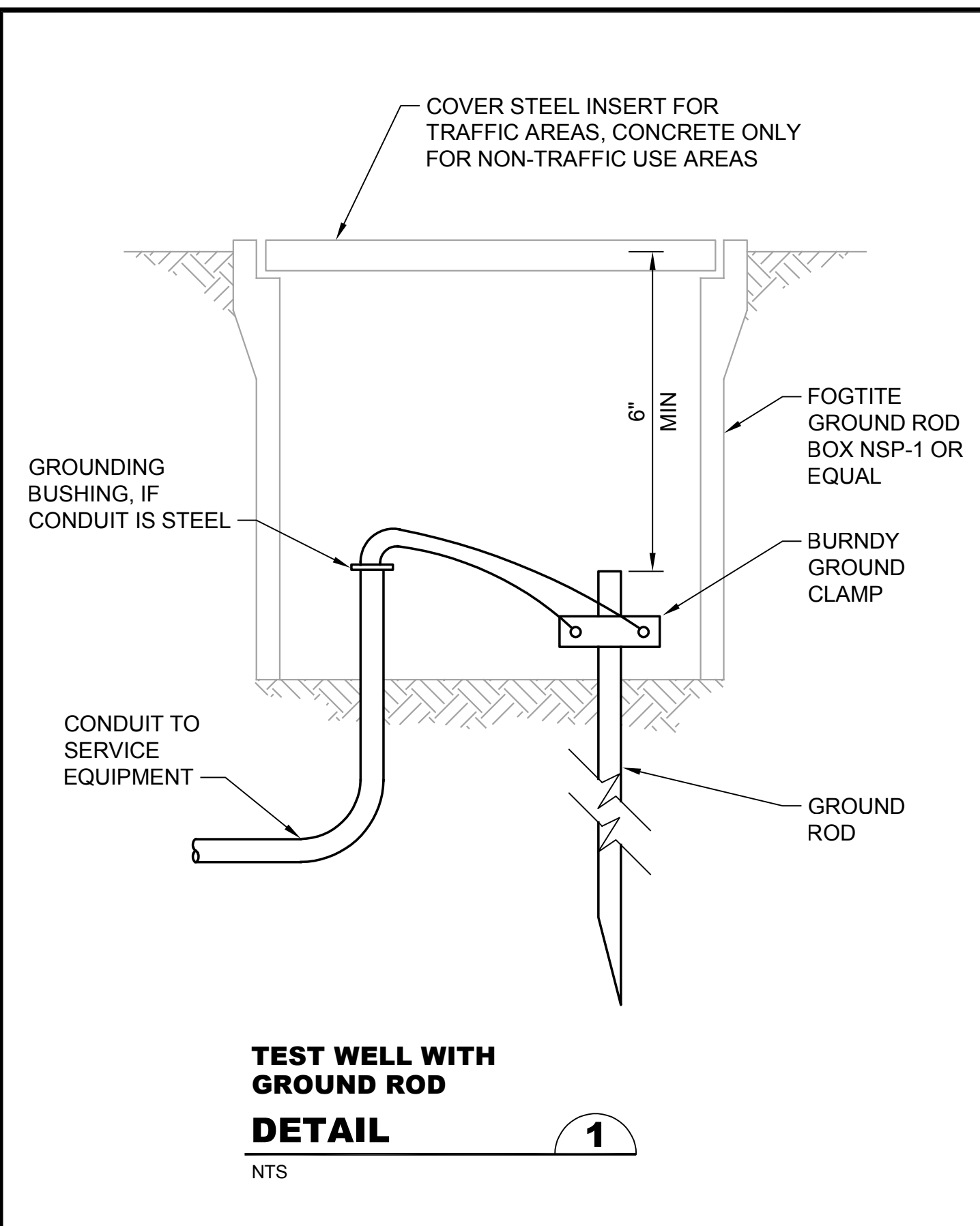

**TEST WELL WITH GROUND ROD DETAIL**  
NTS

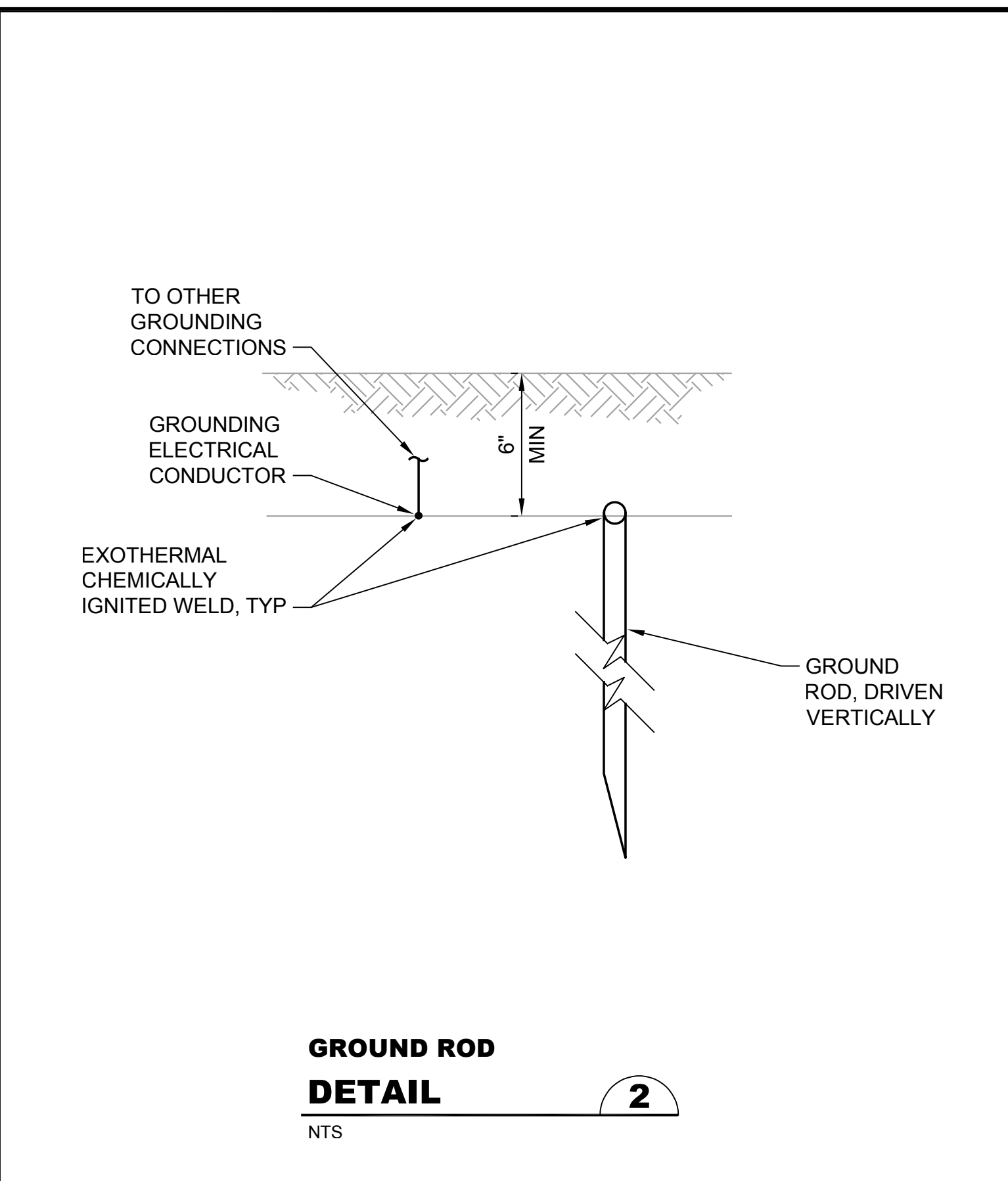

**GROUND ROD DETAIL**  
NTS

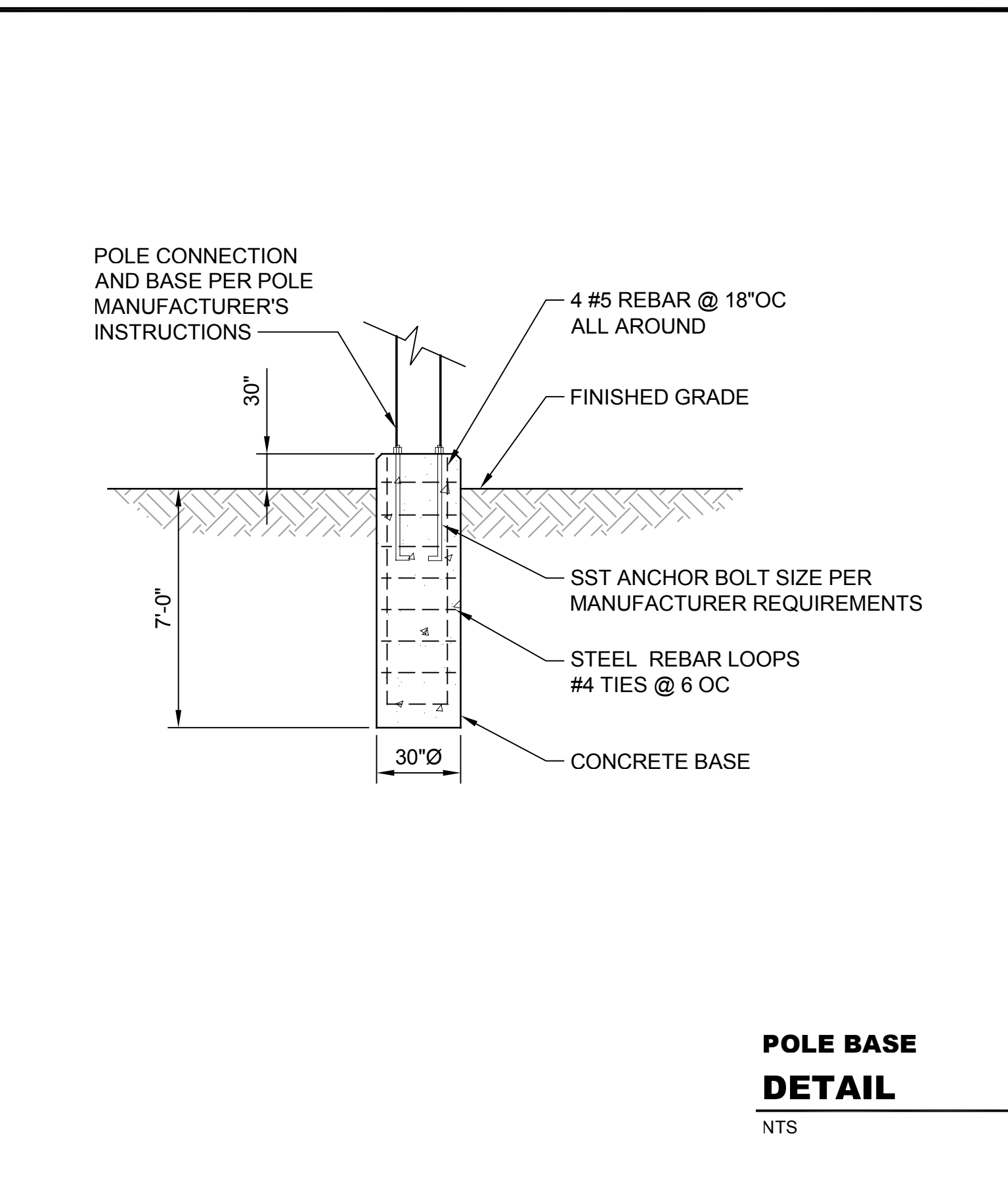

**POLE BASE DETAIL**  
NTS

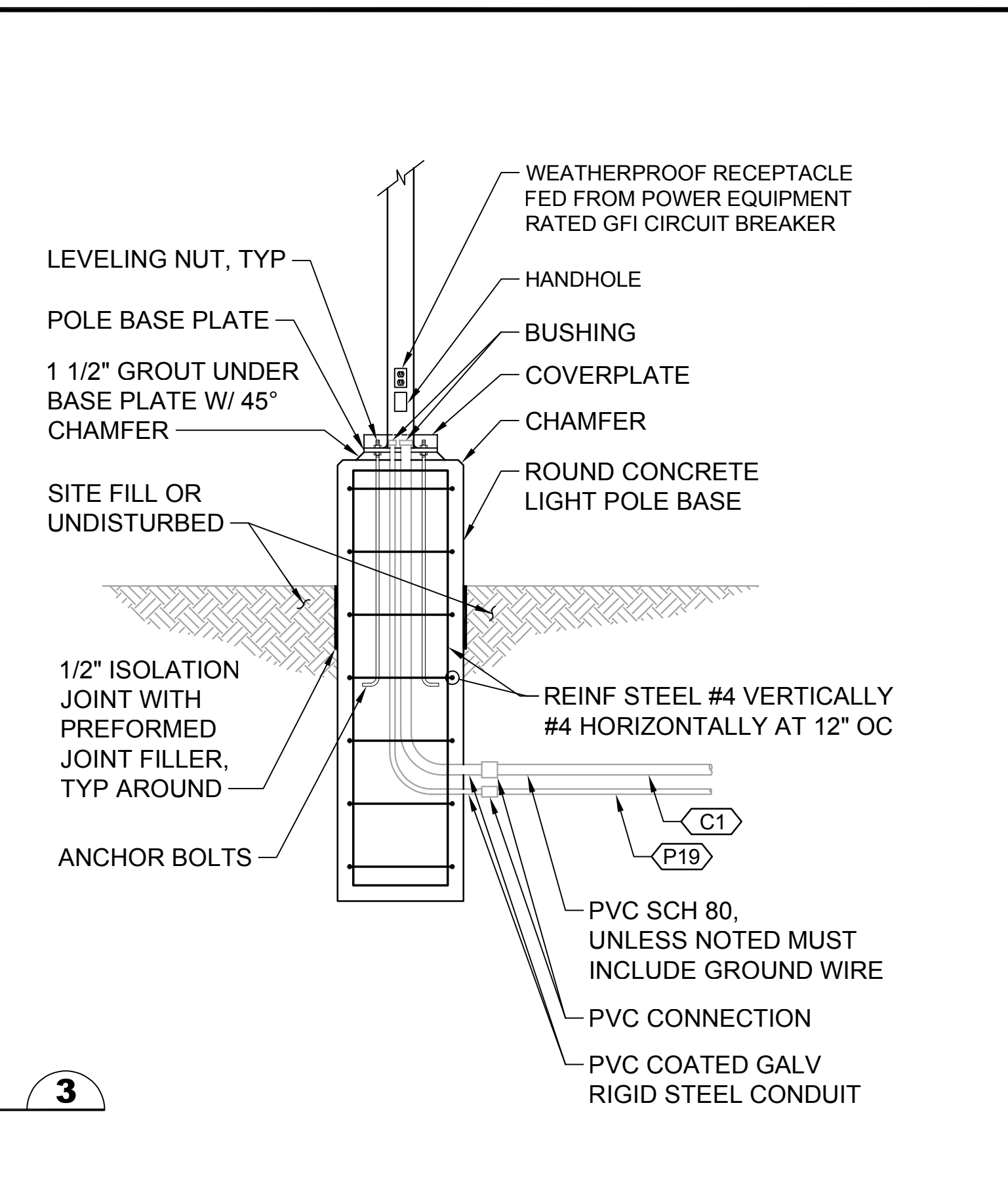

**POLE BASE DETAIL**  
NTS

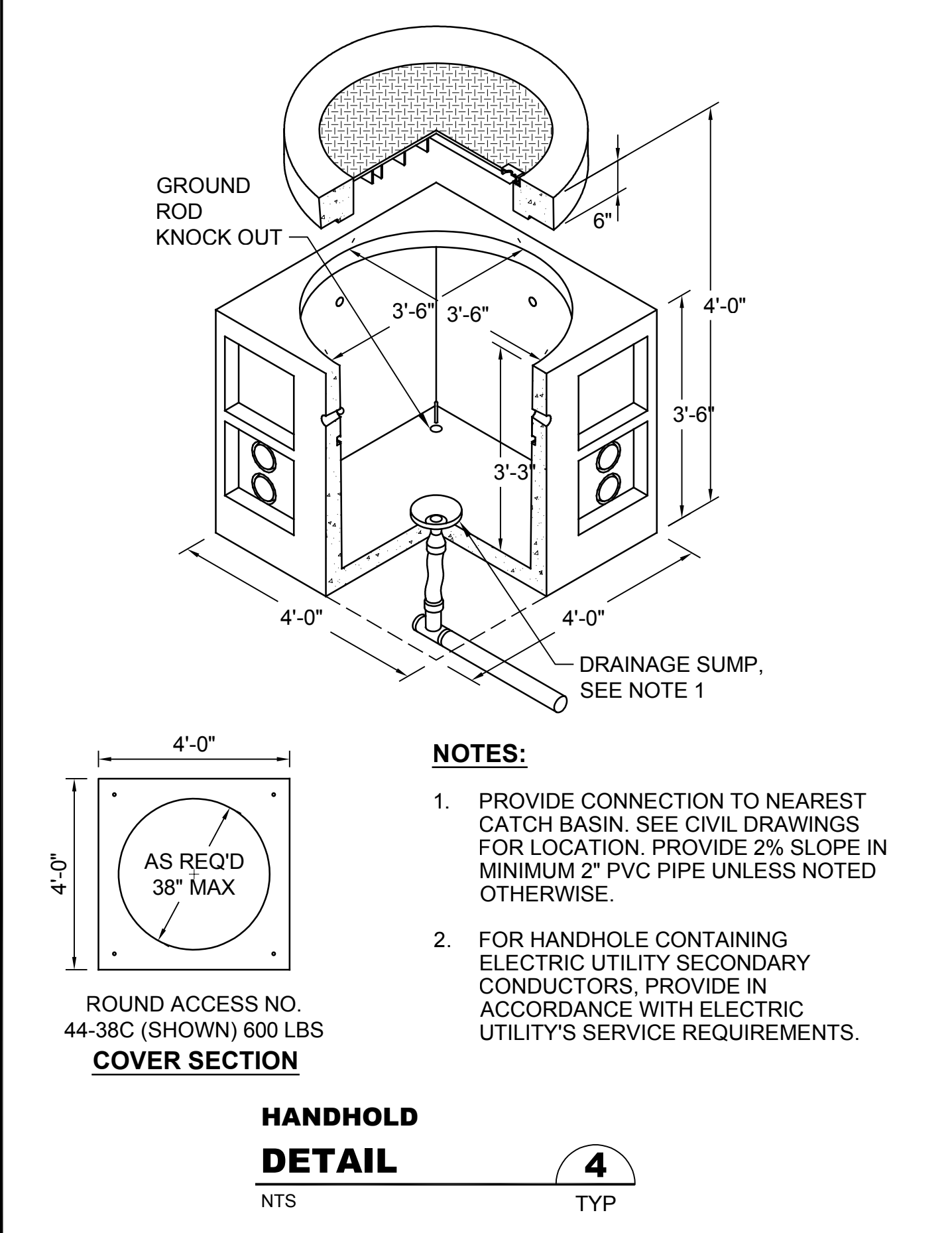

**HANDHOLD DETAIL**  
NTS

- NOTES:**
1. PROVIDE CONNECTION TO NEAREST CATCH BASIN. SEE CIVIL DRAWINGS FOR LOCATION. PROVIDE 2% SLOPE IN MINIMUM 2" PVC PIPE UNLESS NOTED OTHERWISE.
  2. FOR HANDHOLE CONTAINING ELECTRIC UTILITY SECONDARY CONDUCTORS, PROVIDE IN ACCORDANCE WITH ELECTRIC UTILITY'S SERVICE REQUIREMENTS.

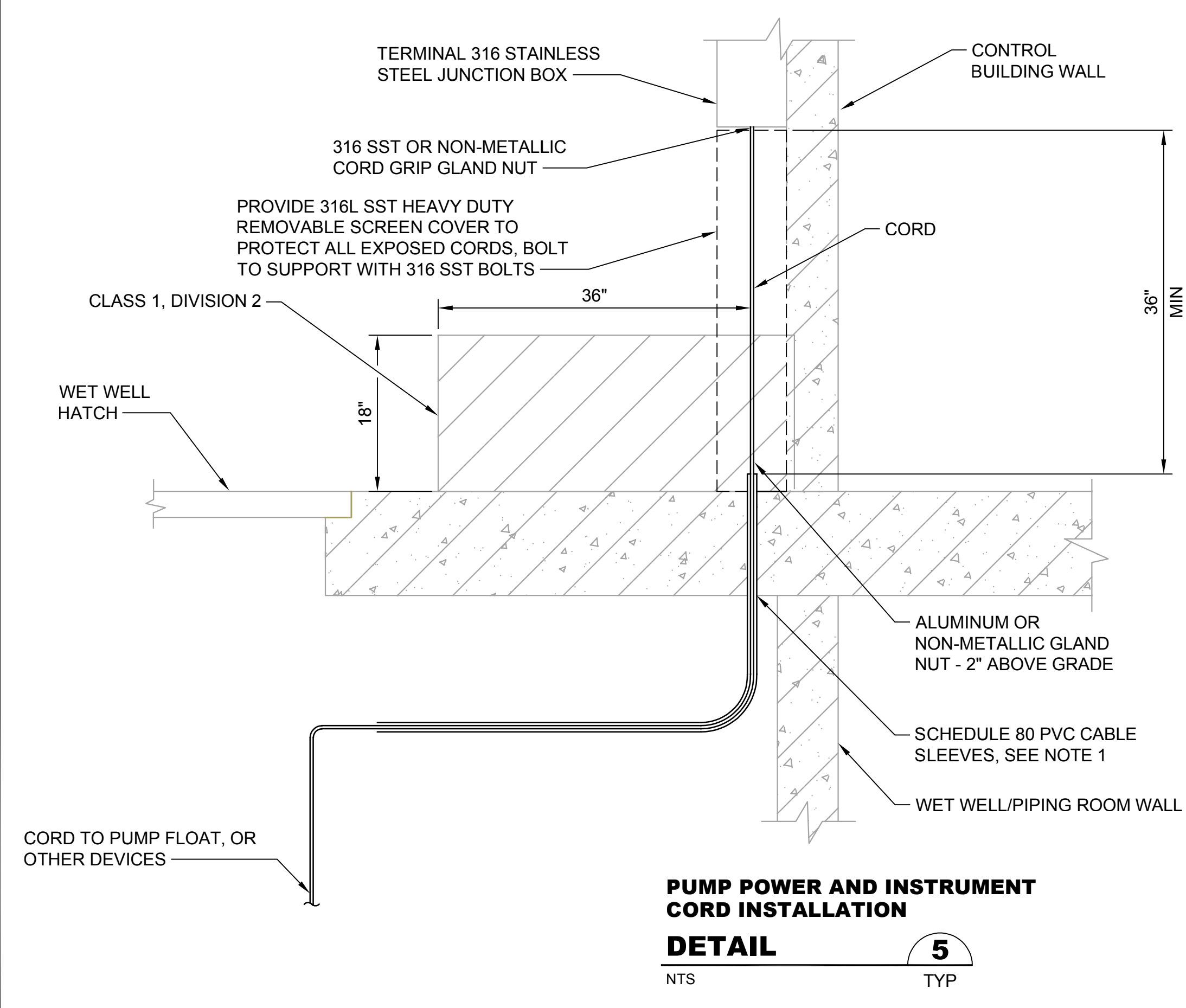

**PUMP POWER AND INSTRUMENT CORD INSTALLATION DETAIL**  
NTS

- NOTES:**
1. PROVIDE INSTALLATION OF CORDS AND OTHER COMPONENTS SO THAT THEY CAN BE EASILY PULLED BACK THROUGH THE SLEEVE INTO THE WET WELL FOR REMOVAL OF THE EQUIPMENT OR INSTRUMENTATION.
  2. WHERE SLEEVE EMERGES ABOVE GRADE IT SHALL TRANSITION TO THREADED ALUMINUM RIDGED RACEWAY. ALUMINUM RACEWAY SHALL BE WRAPPED WITH A PROTECTIVE TAPE WHERE IN CONTACT WITH CONCRETE.
  3. SEAL ALL CONDUITS WITH RE-ENTERABLE CONDUIT SEALING PUTTY.

**Call 48 Hours Before You Dig**  
1-800-424-5555  
UNDERGROUND SERVICE

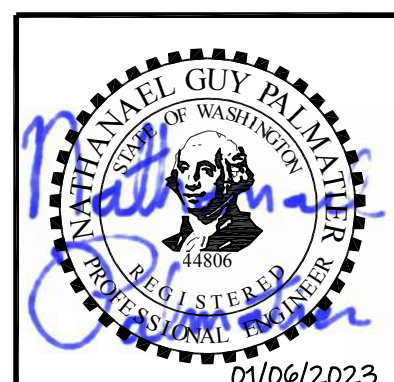

Path: S:\CAD\Kitsap County\21-10530 Silverdale Conveyance-PS 4 Uprgt\Design\Drawings\21-10530\_E-24C.dwg Plot date: Jan 06, 2023 12:44:41pm CAD User: soisce  
Xref Filename: 21-10530\_TB | Palmatier | Daniel | Fisher |

No.	Revision	Date	By	App'd
	ISSUED FOR BID	01-2023	TF	RAD

**bhc CONSULTANTS**  
BHC Consultants, LLC  
1601 Fifth Avenue, Suite 500  
Seattle, Washington 98101  
206.505.3400  
206.505.3406 (fax)  
www.bhcconsultants.com

Designed: N. Palmatier, P.E.  
Drawn: J. Lira  
Checked: R. Dorn, P.E.  
Scale: NTS  
One Inch at Full Scale  
If Not One Inch Scale Accordingly

**Kitsap County Public Works**  
614 Division Street, MS 26  
Port Orchard, WA 98366

**SILVERDALE CONVEYANCE SYSTEM AND PUMP STATION 4 UPGRADES SCHEDULE C**  
**ELECTRICAL DETAILS**  
**1 OF 4**

Drawing: **E-24C**  
Sheet: **110** of **117**  
File: P21-10530\_E-24C  
Date: January 2023

Path: S:\Cad\Kitsap County\21-10530 Silverdale Convey-PS 4 Upgr\Design\Drawings\21-10530\_E-25C\_Plot.dwg Plot date: Jan 06, 2023 11:53:20am CAD User: soisee  
 Xref Filename: 1\21-10530\_TB | Palmatier | Datt | Fisher |

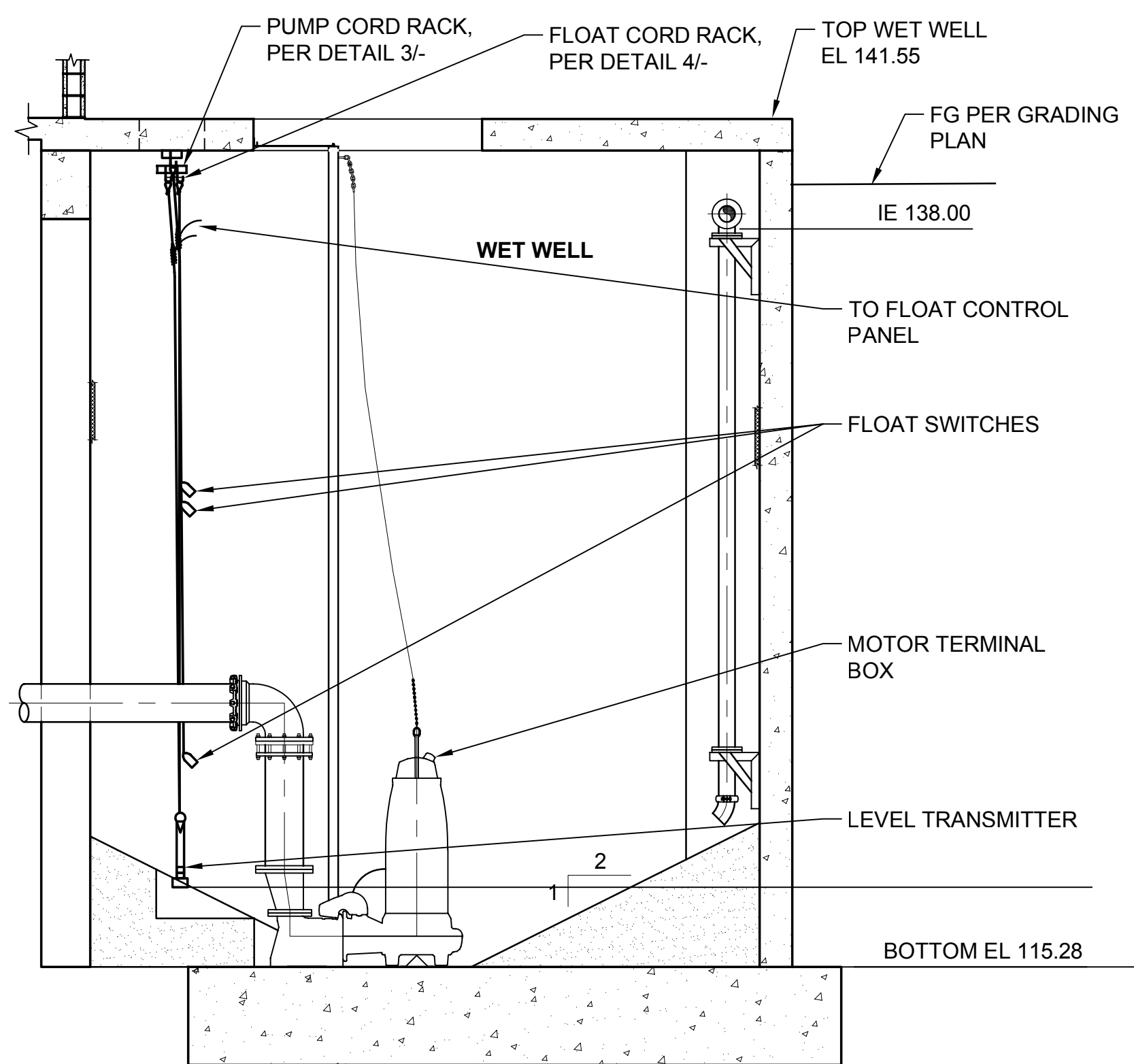

**NOTES:**

1. PROVIDE 3" MINIMUM SEPARATION OF HIGH LEVEL FLOATS SO THAT THE PUMPS WILL HAVE STAGGERED START.
2. INSTALL ALL HOOKS TO BE ACCESSIBLE FROM OUTSIDE THE WET WELL SO THAT THE FLOATS AND LEVEL TRANSDUCER CAN BE ADJUSTED AND REMOVED WITHOUT ENTERING THE WET WELL.
3. GROUT AND LEVEL TRANSMITTER ARE FOR CLARITY.

**WET WELL ELECTRICAL  
 DETAIL 1**  
 NTS

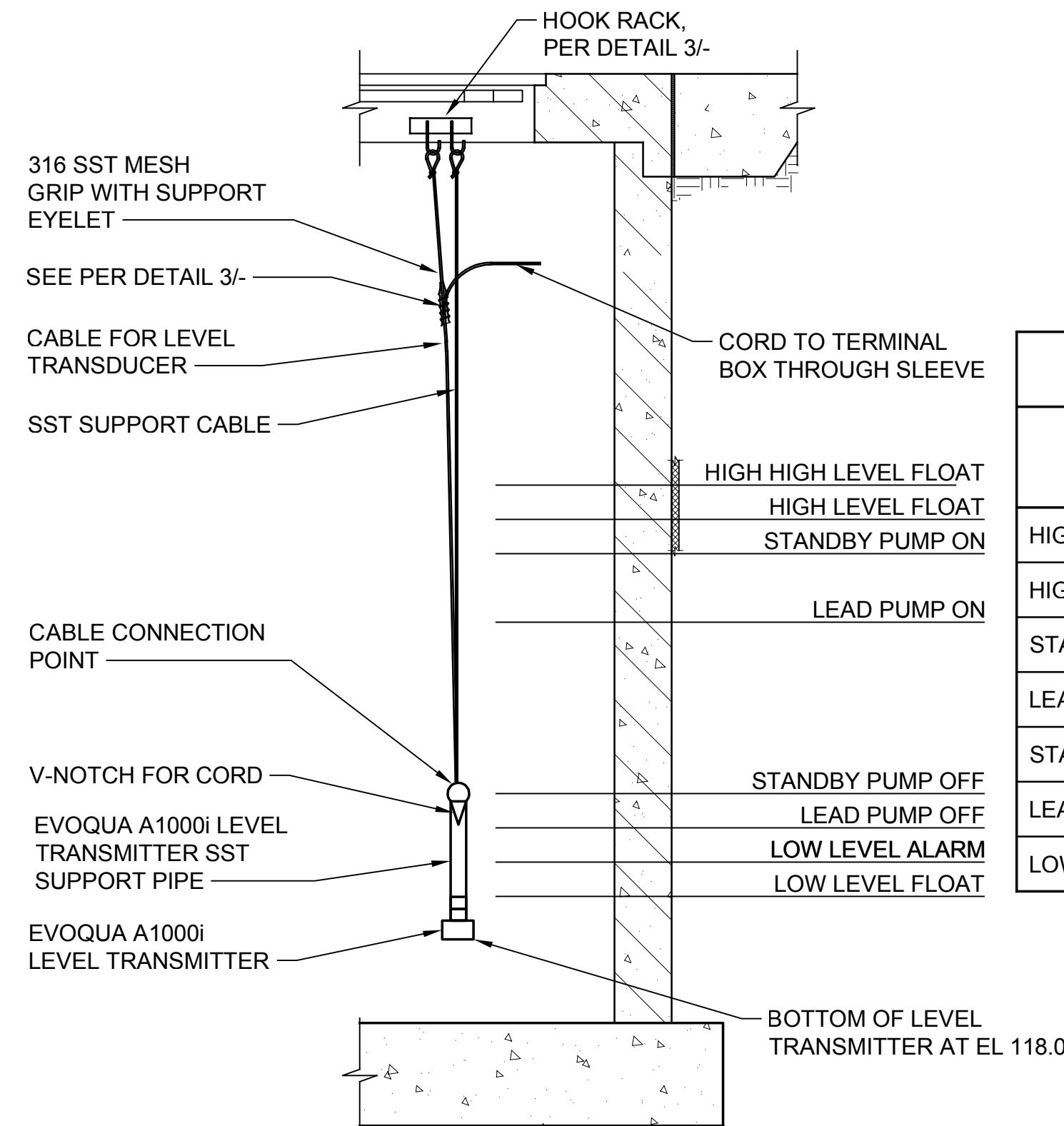

**NOTES:**

1. INSTALL LEVEL TRANSDUCER AWAY FROM TURBULENCE.
2. THE LEVEL TRANSDUCER IS SUSPENDED BY A STAINLESS STEEL CABLE.
3. KEEP THE SIGNAL CABLE AS FAR AWAY FROM OTHER CABLES AS POSSIBLE. PROVIDE ONLY 18" OF EXTRA CABLE.
4. EXTEND SCH80 PVC TO ACCESSIBLE DISTANCE THROUGH ACCESS HATCH.
5. GROUT IS NOT SHOWN FOR CLARITY.

**LEVEL TRANSMITTER  
 DETAIL 2**  
 NTS

WET WELL OPERATION LEVELS		
DESCRIPTION	FLOAT ELEVATION	TRANSMITTER ELEVATION
HIGH-HIGH LEVEL FLOAT	126.5	
HIGH LEVEL FLOAT	126.0	
STANDBY PUMP ON		125.0
LEAD PUMP ON	125.0	124.5
STANDBY PUMP OFF		121.5
LEAD PUMP OFF		120.0
LOW LEVEL ALARM	119.5	119.5

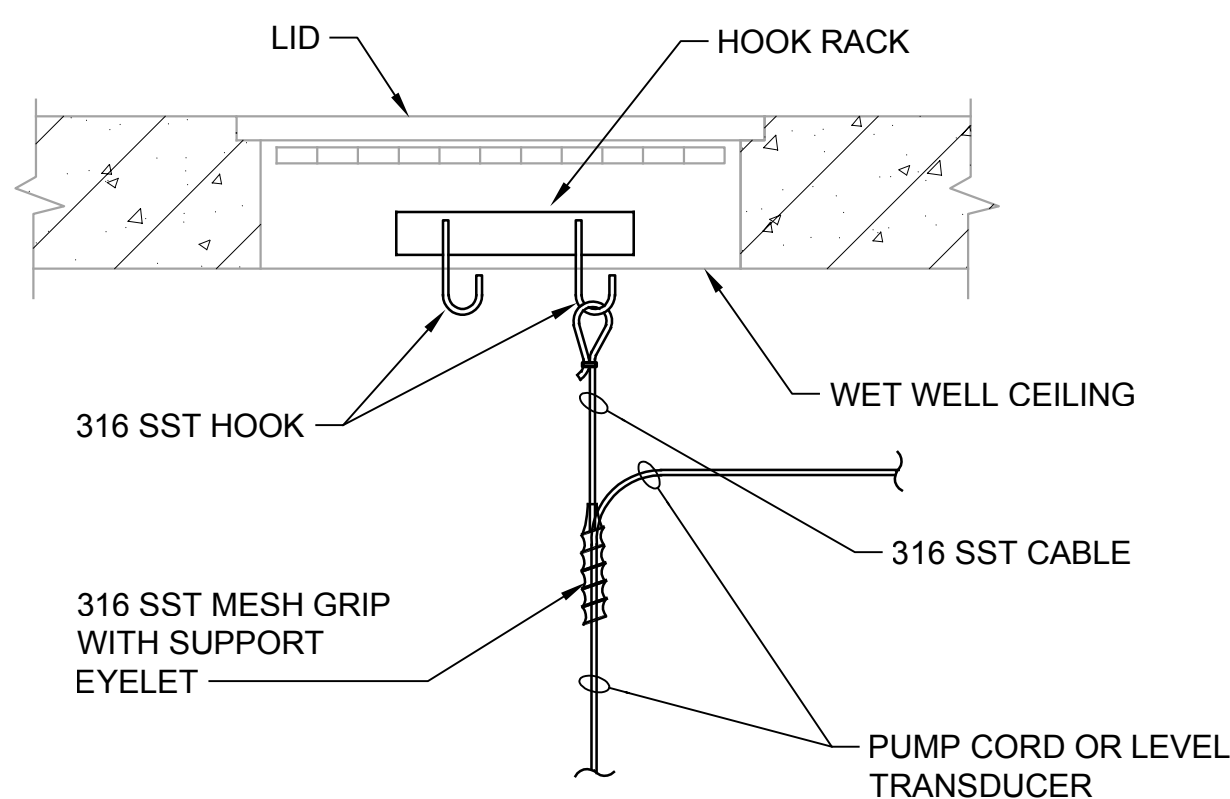

**POWER AND INSTRUMENT  
 CORD INSTALLATION  
 DETAIL 3**  
 NTS

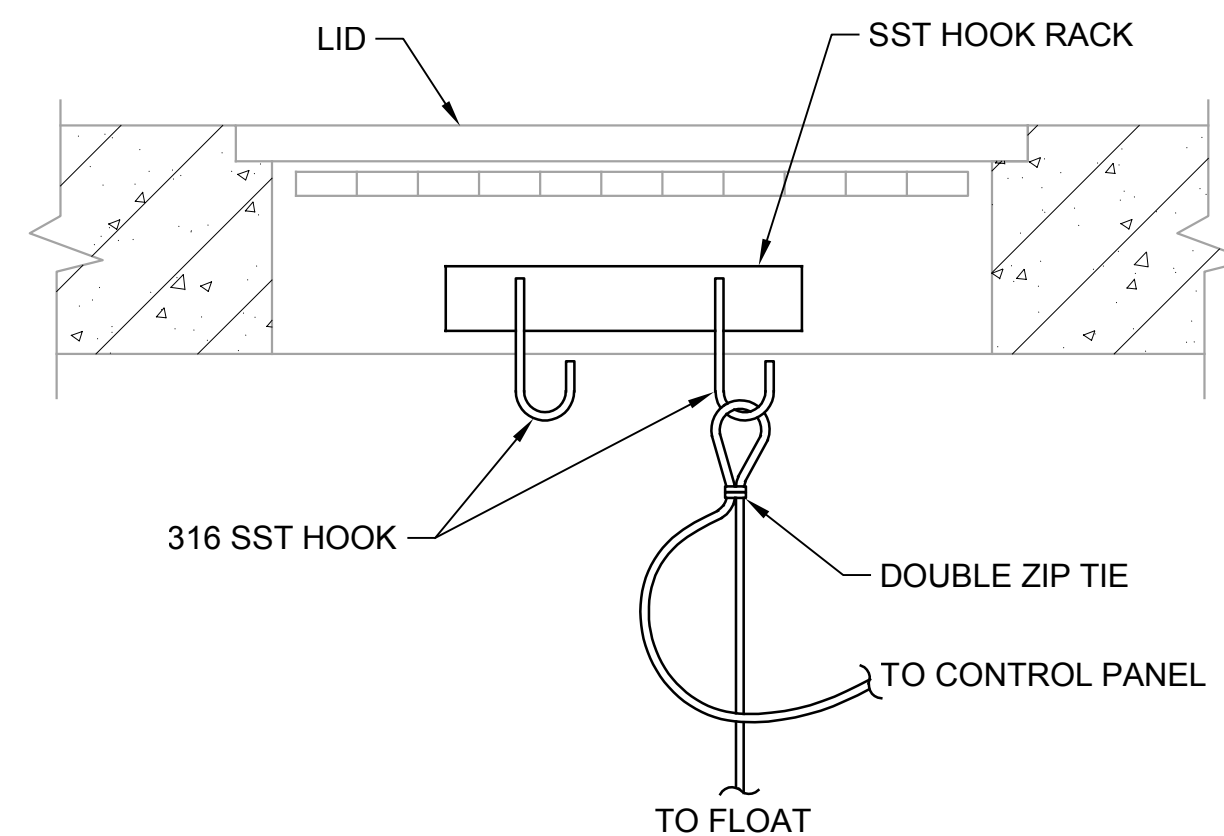

**FLOAT CORD  
 INSTALLATION  
 DETAIL 4**  
 NTS

**Call 48 Hours  
 Before You Dig**  
 1-800-424-5555  
 UNDERGROUND SERVICE

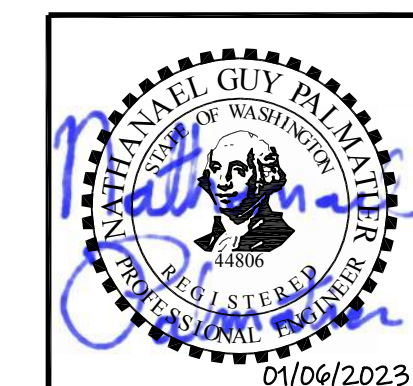

**bhc**  
 CONSULTANTS  
**BHC Consultants, LLC**  
 1601 Fifth Avenue, Suite 500  
 Seattle, Washington 98101  
 206.505.3400  
 206.505.3406 (fax)  
 www.bhcconsultants.com

Designed: N. Palmatier, P.E.  
 Drawn: J. Lira  
 Checked: R. Dorn, P.E.

Scale:  
 NTS  
 One Inch at Full Scale  
 If Not One Inch  
 Scale Accordingly



**Kitsap County Public Works**  
 614 Division Street, MS 26  
 Port Orchard, WA 98366

**SILVERDALE CONVEYANCE SYSTEM AND PUMP STATION 4 UPGRADES  
 SCHEDULE C  
 ELECTRICAL DETAILS  
 2 OF 4**

Drawing: **E-25C**  
 Sheet: **111** of **117**  
 File: P21-10530\_E-25C  
 Date: January 2023

Path: S:\Cadd\Kitsap County\21-10530 Silverdale Conveyance PS 4 Upgr\Design\Drawings\21-10530\_E-26C.dwg Plot date: Jan 06, 2023 11:55:32am CAD User: soisce  
 Xref Filename: 1\21-10530\_TB | Palmatier | Datt | Fisher |

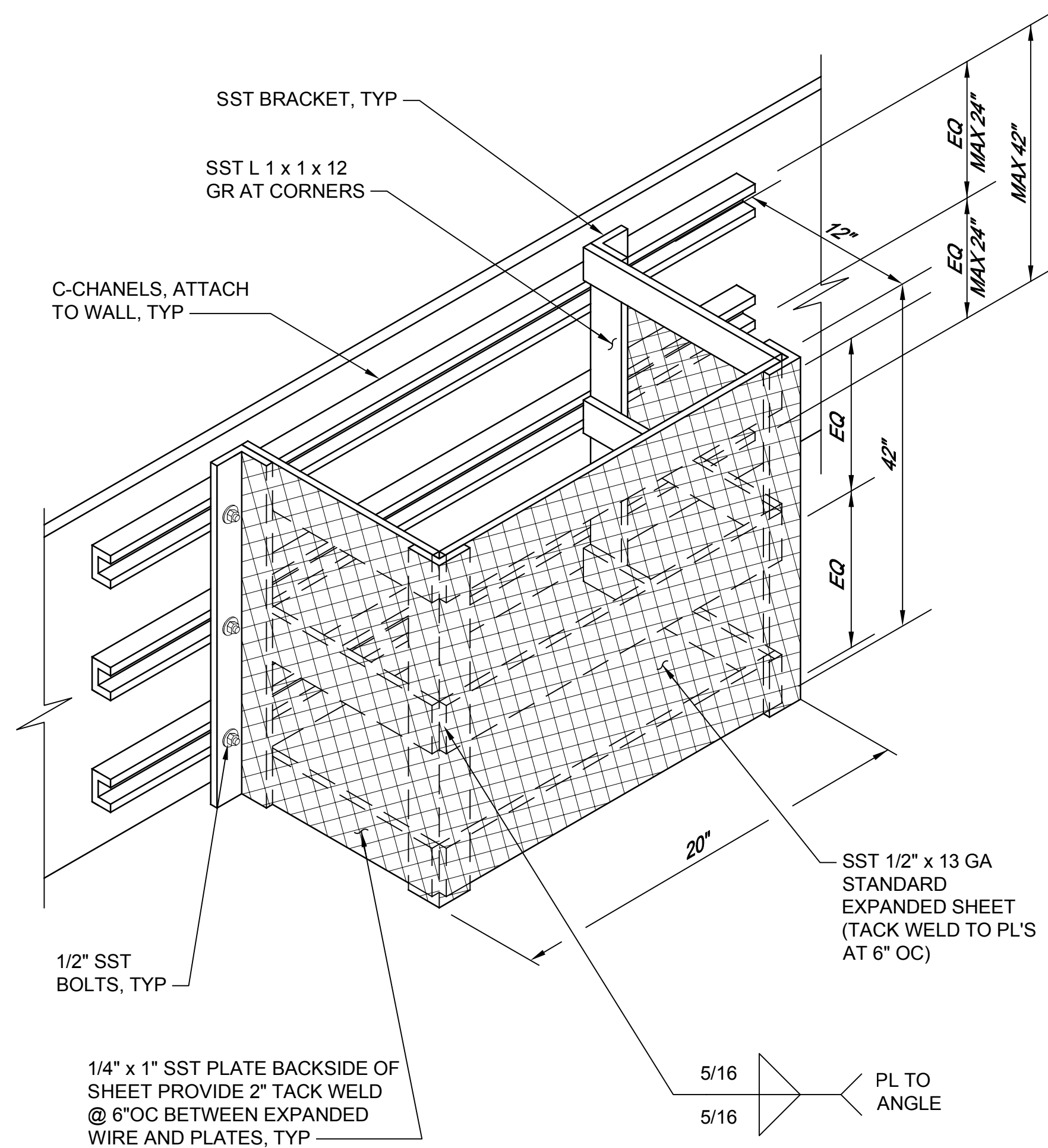

**CABLE GUARD  
DETAIL 1**  
NTS

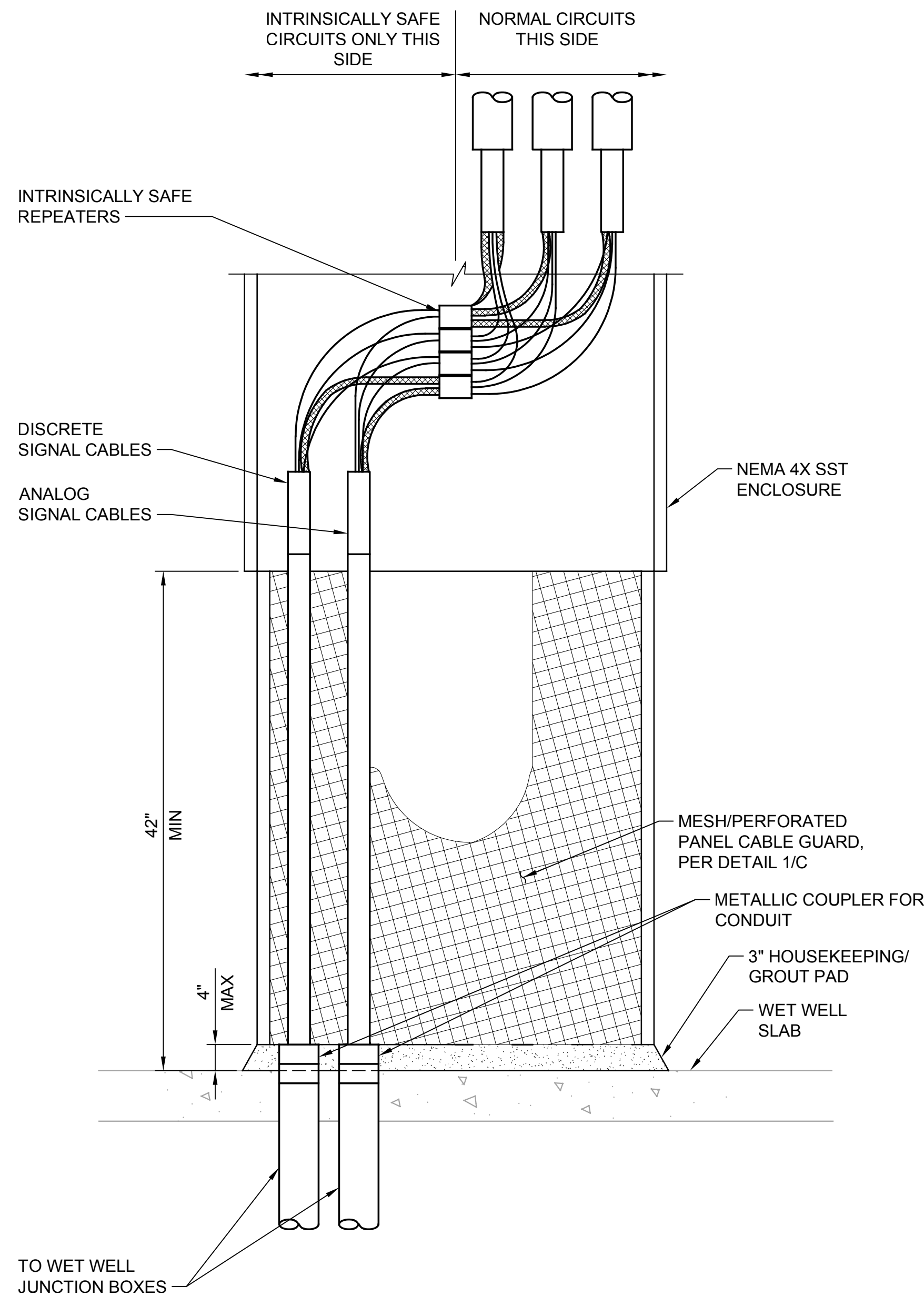

**NOTE:**  
1. PROVIDE SEAL CONDUIT BODIES IF NEEDED.

**BACKUP FLOAT CONTROL PANEL  
DETAIL 2**  
NTS

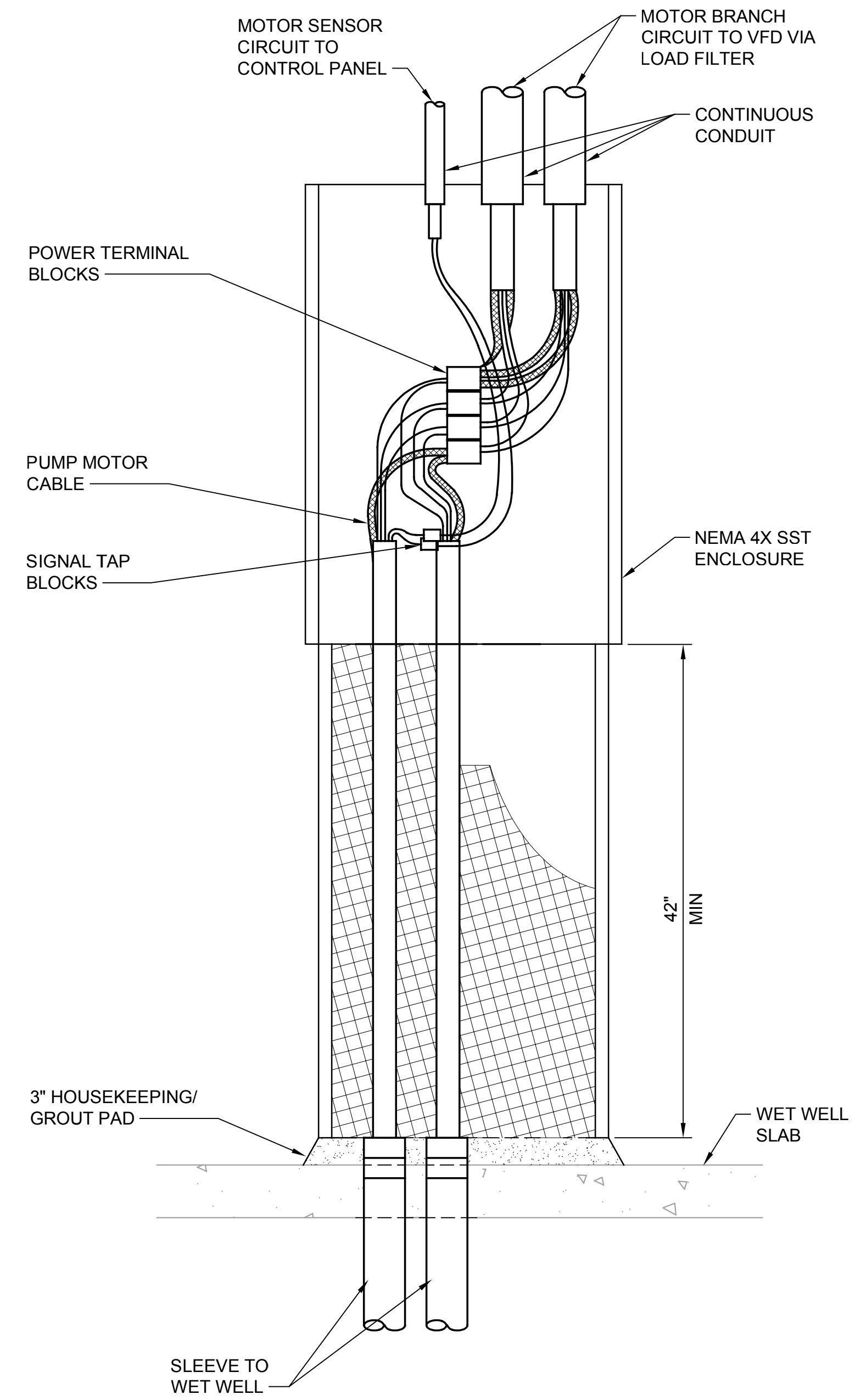

**MOTOR CABLE  
TERMINAL JUNCTION BOX  
DETAIL 3**  
NTS

**Call 48 Hours  
Before You Dig**  
1-800-424-5555  
UNDERGROUND SERVICE

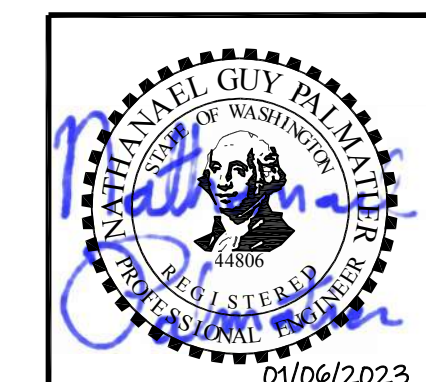

No.	Revision	Date	By	App'd
	ISSUED FOR BID	01-2023	TF	RAD

**bhc**  
CONSULTANTS

**BHC Consultants, LLC**  
1601 Fifth Avenue, Suite 500  
Seattle, Washington 98101  
206.505.3400  
206.505.3406 (fax)  
www.bhcconsultants.com

Designed: N. Palmatier, P.E.  
Drawn: J. Lira  
Checked: R. Dorn, P.E.

Scale:  
NTS  
One Inch at Full Scale  
If Not One Inch Scale Accordingly

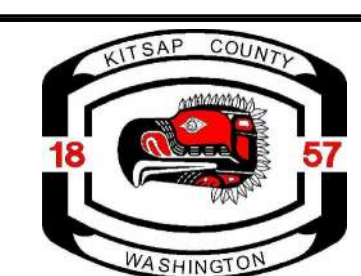

**Kitsap County Public Works**  
614 Division Street, MS 26  
Port Orchard, WA 98366

**SILVERDALE CONVEYANCE SYSTEM AND PUMP STATION 4 UPGRADES  
SCHEDULE C  
ELECTRICAL DETAILS  
3 OF 4**

Drawing: **E-26C**  
Sheet: **112** of **117**  
File: P21-10530\_E-26C  
Date: January 2023



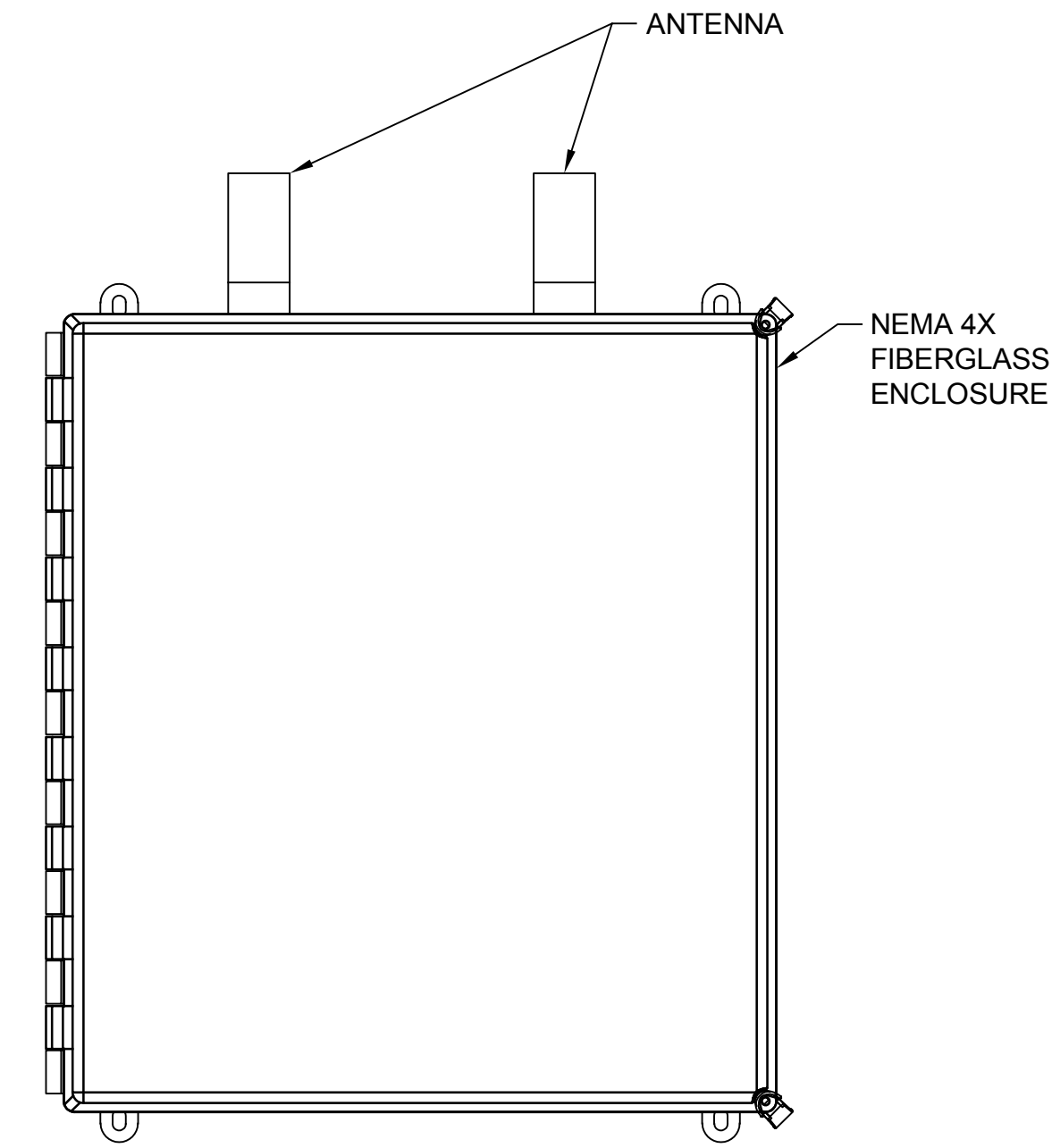
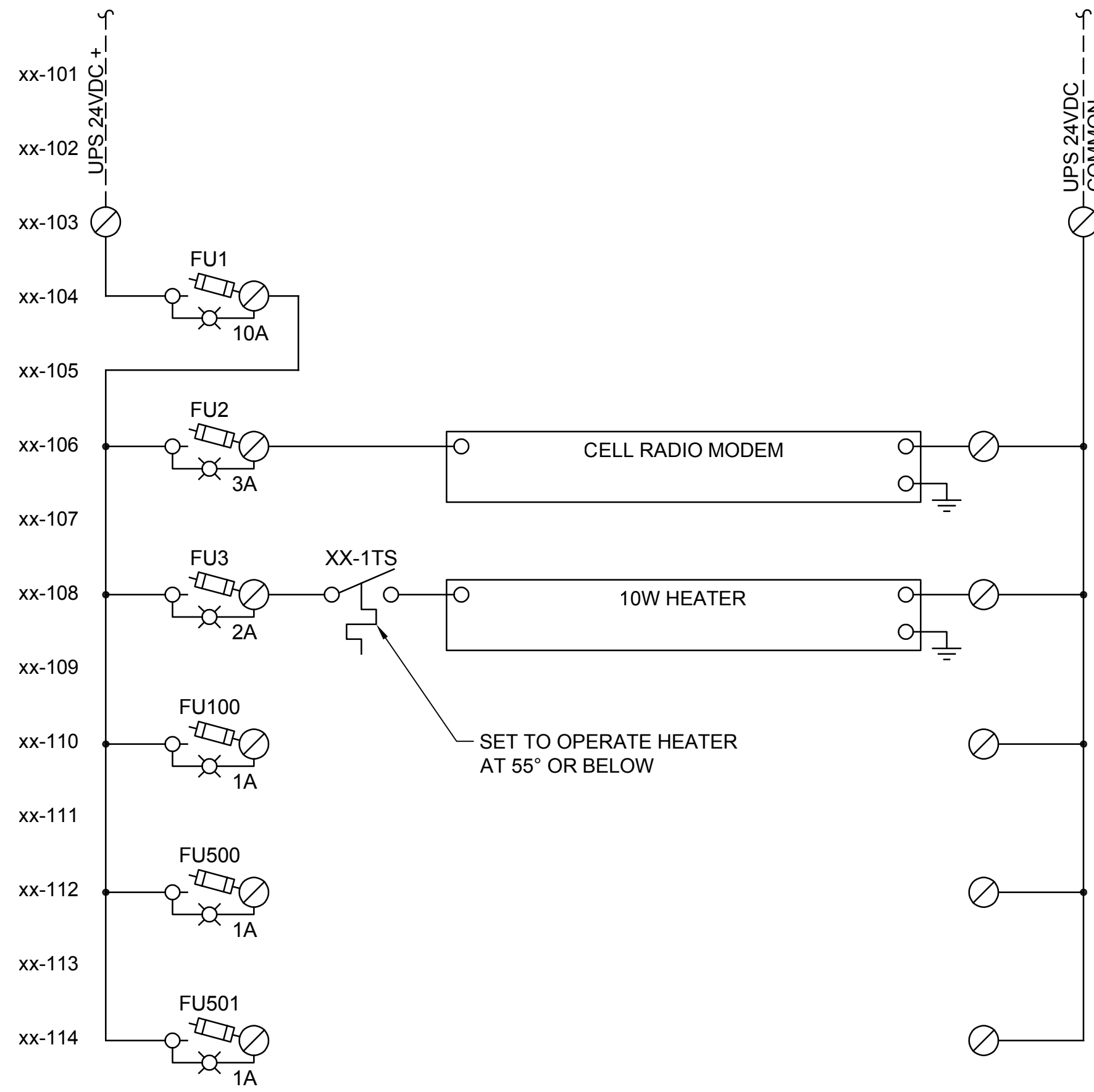

**EXTERIOR VIEW  
RADIO ENCLOSURE  
DETAIL**

NTS

1

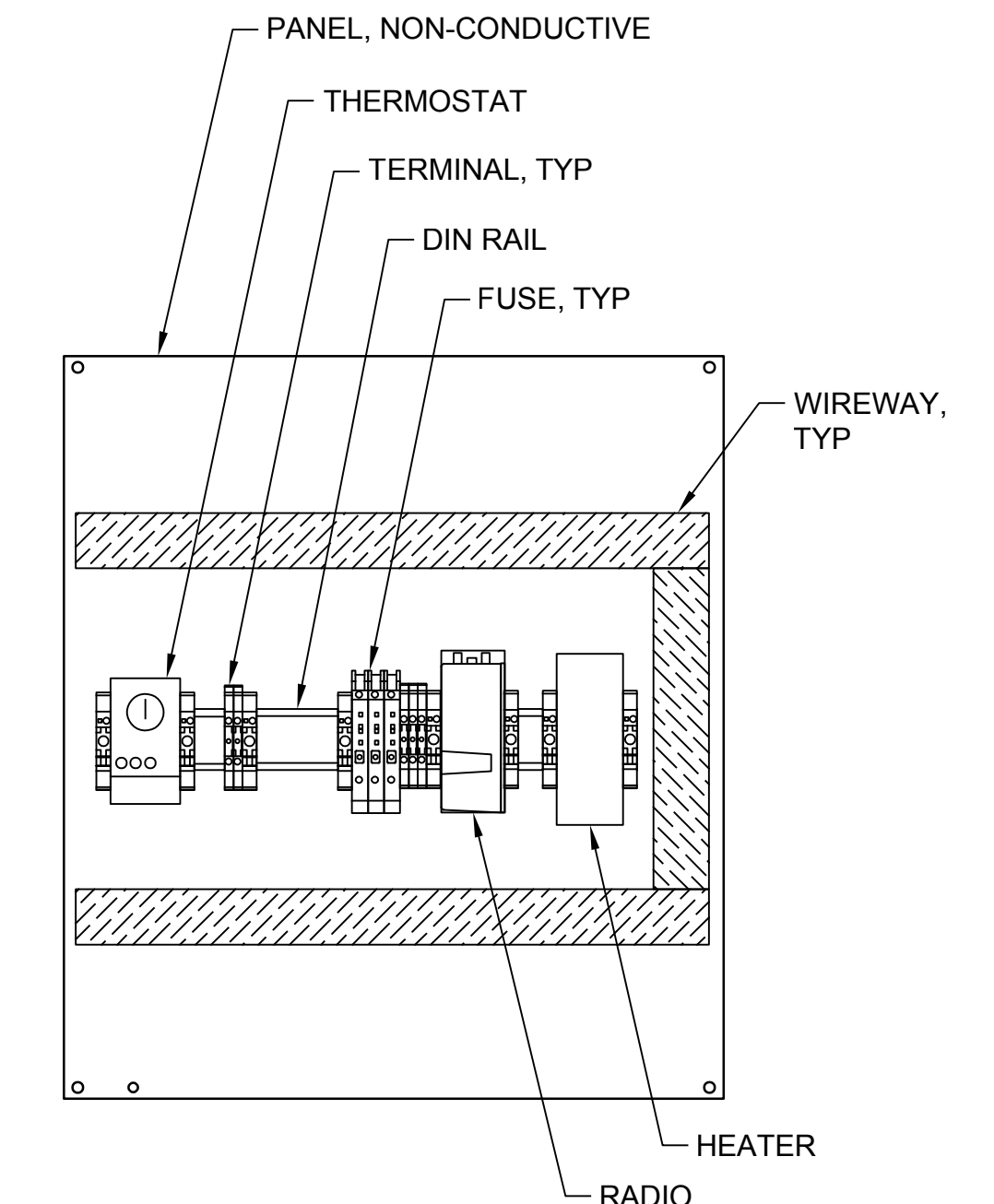

**INTERIOR VIEW  
RADIO ENCLOSURE  
DETAIL**

NTS

2

Path: S:\Cad\Kitsap County\21-10530 Silverdale Convey-PS 4 Upgr\Design\Drawings\21-10530\_E-27C.dwg Plot date: Jan 06, 2023 11:57:45am CAD User: soisce  
Xref Filename: I:\21-10530\_TB\Palmatier\Drawings\Fisher

**Call 48 Hours  
Before You Dig**  
1-800-424-5555  
UNDERGROUND SERVICE

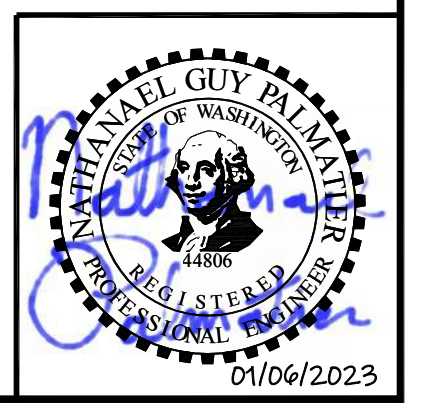

No.	Revision	Date	By	App'd
	ISSUED FOR BID	01-2023	TF	RAD

**bhc**  
CONSULTANTS

**BHC Consultants, LLC**  
1601 Fifth Avenue, Suite 500  
Seattle, Washington 98101  
206.505.3400  
206.505.3406 (fax)  
www.bhcconsultants.com

Designed: N. Palmatier, P.E.  
Drawn: A. Bradley  
Checked: R. Dorn, P.E.

Scale:  
NTS  
One Inch at Full Scale  
If Not One Inch  
Scale Accordingly



**Kitsap County Public Works**  
614 Division Street, MS 26  
Port Orchard, WA 98366

**SILVERDALE CONVEYANCE SYSTEM AND PUMP STATION 4 UPGRADES  
SCHEDULE C**  
**ELECTRICAL DETAILS**  
**4 OF 4**

Drawing: **E-27C**  
Sheet: **113** of **117**  
File: P21-10530\_E-27C  
Date: January 2023

Path: S:\CAD\Kitsap County\21-10530 Silverdale Conveyance-PS 4 UprgrDesign\Drawings\21-10530\_E-28C\_Plot.dwg Plot date: Jan 06, 2023 12:00:21pm CAD User: soisee  
Xref Filename: 21-10530\_TB | Palmatier | Dan | Fisher |

LOAD CALCULATIONS			
NEC 220 DEMAND CALCULATIONS			
792105 VA	3 PH VA CONNECTED		
917.6 A	AMPS	480 V	
1029.0 A	DEMAND A	480 V	(TOTAL STATION LOAD)
56.3 A	DEMAND A	208 V	(PANEL LA1)
<b>GENERATOR</b>			
390604 W	CALCULATED [W]	490.00 kW	ENGINE GENERATOR SIZE
470.0 A	CALCULATED [A @ 480VAC]		
<b>PSE CALCULATIONS</b>			
3000 VA	HEATING	2.92 kW	
763171 VA	MOTOR	743.33 kW	
1558 VA	NONC	1.52 kW	
2878 VA	REC	2.80 kW	
21498 VA	CONTINUOUS	20.94 kW	
0 VA	ELEVATOR	0.00 kW	
3000 VA	HEATING	3.00 kW	*INCLUDES HEAT PUMP
2600 VA	COOLING	2.60 kW	*COOLING OF HEAT PUMP
0 VA	REFRIDGERATION	0.00 kW	
6864 VA	WATER HEATING	6.86 kW	
1558 VA	LIGHTING	1.52 kW	
0 VA	COOKING	0.00 kW	
17512 VA	MISCELLANEOUS	17.06 kW	
763171 VA	OTHER MOTORS	743.33 kW	
792105 VA	TOTAL NEW CONNECTED LOAD	771.77 kW	
792105 VA	EST. TOTAL LOAD	771.77 kW	

LIGHTING FIXTURE SCHEDULE										
		A24	A24	A48	A48X	C	FF	GG	HH	TYPE
		19.9 W	19.9 W	37.8 W	37.8 W	9.6 W	21.0 W	28.0 W	133.0 W	WATT/FIX
<b>AREA</b>	<b>WATT / AREA</b>									
CONTROL ROOM	286.50 W	2	1	5	1					
BATHROOM	85.21 W			2		1				
STAIRWELL	75.60 W			1	1					
VALVE ROOM	340.20 W			8	1					
										<b>CKT 2</b>
										<b>787.5 W</b>
										<b>6.6 A</b>
EXTERIOR DRIVE	532.00 W								4	
EXTERIOR NORTH	28.00 W							1		
EXTERIOR EAST	98.00 W					2	2			
EXTERIOR SOUTH WALL	56.00 W							2		
EXTERIOR WEST WALL	56.00 W							2		
										<b>CKT 4</b>
										<b>770.0 W</b>
										<b>6.4 A</b>

SWITCHBOARD UNIT SCHEDULE			
CIRCUIT		TYPE	DESCRIPTION
SERVICE	1	A	
SERVICE	1	B	BRANCH
SERVICE	2	A	SPD
SERVICE	2	B	BRANCH
SERVICE	3		EUSERC METER

LIGHTING FIXTURE SCHEDULE					
TYPE	MIN LUMENS	WATT/FIX	MNF	PN	DESCRIPTION
A24	3000	19.9	LITHONIA	FEM L24 3000LM LPPCL MD MVOLT GZ10 40K 80CRI	24" LINEAR LED FIXTURE, 4000K LIGHT, ACRYLLIC LENS
A48	6000	37.8	LITHONIA	FEM L48 6000LM LPPCL MD MVOLT GZ10 40K 80CRI	48" LINEAR LED FIXTURE, 4000K LIGHT, ACRYLLIC LENS
A48X	6000	37.8	LITHONIA	FEM L48 6000LM LPPCL MD MVOLT GZ10 40K 80CRI E10WMCP	48" LINEAR LED FIXTURE, 4000K LIGHT, ACRYLLIC LENS, 90 MINUTE BATTERY
C	800	9.61	LITHONIA	FMVCLS 12IN MVOLT 30K35K40K 90CRI KR	OVER-SINK VANITY LIGHT FIXTURE
FF	2800	21	LITHONIA	DSXF1 LED P1 40K NSP MVOLT THK SF DDBXD	FLOOD SPOT, BUILDING MOUNTED
GG	3400	28	LITHONIA	TWR1 LED P2 50K MVOLT PE SF DDBTXD	LED WALL PACK, PHOTOEYE CONTROL
HH	16000	133	LITHONIA	RSX1 LED P4 50K R3 MVOLT RPA PE SF DDBTXD	POLE MOUNTED, LED AREA LIGHT, PHOTOEYE, TYPE 3 WIDE DISTRIBUTION
P15			LITHONIA	RSS 15 DM19AS EHH3B UL DDBXD	15' POLE ROUND STEEL POLE
P25			LITHONIA	RSS 25 DM19AS EHH3B UL DDBXD	20' POLE ROUND STEEL POLE

PANEL SCHEDULE - PANEL LA				
CKT	OCPD	MIN CONDUIT	CONDUCTORS	DESCRIPTION
LA-01	1P-20A GFCI	3/4"C	1#12 & 1#12N & 1#12G	DRY WELL/STAIRWELL RECEPTACLES
LA-03	1P-20A GFCI	3/4"C	1#12 & 1#12N & 1#12G	DRY WELL/STAIRWELL RECEPTACLES
LA-05	1P-20A	3/4"C	1#12 & 1#12N & 1#12G	ELECTRICAL ROOM RECEPTACLES
LA-07	1P-20A	3/4"C	1#12 & 1#12N & 1#12G	ELECTRICAL ROOM RECEPTACLES
LA-09	1P-20A GFCI	3/4"C	1#12 & 1#12N & 1#12G	EXTERIOR RECEPTACLES
LA-11	1P-20A GFCI	3/4"C	1#12 & 1#12N & 1#12G	EXTERIOR RECEPTACLES
LA-13	1P-20A	3/4"C	1#12 & 1#12N & 1#12G	ELECTRICAL ROOM CONTROL PANEL
LA-15	1P-20A	3/4"C	1#12 & 1#12N & 1#12G	ELECTRICAL ROOM CONTROL PANEL
LA-17	1P-20A			
LA-19	1P-15A GFCI	3/4"C	1#12 & 1#12N & 1#12G	ENGINE GENERATOR OIL ALT. BATTERY HEATER
LA-21	1P-15A GFCI	3/4"C	1#12 & 1#12N & 1#12G	ENDING GENERATOR COOLANT CCV HEATER
LA-23	1P-20A GFCI			
LA-25	1P-20A			
LA-27	1P-20A			
LA-29	1P-20A			
LA-31	1P-20A			
LA-33	1P-20A			
LA-35	1P-20A			
LA-37	1P-20A			
LA-39	1P-20A			
LA-41	1P-20A			
LA-02	1P-15A	3/4"C	1#12 & 0#12N & 1#12G	EXTERIOR LIGHTS
LA-04	1P-15A	3/4"C	1#12 & 1#12N & 1#12G	INTERIOR LIGHTS
LA-06	1P-15A			
LA-08	1P-15A 30MA GFI	3/4"C	1#12 & 1#12N & 1#12G	WATER SERVICE HOTBOX
LA-10	1P-15A 30MA GFI	3/4"C	1#12 & 1#12N & 1#12G	ODOR CONTROL PIPING HEAT TRACE
LA-12	1P-15A			
LA-14	1P-20A			
LA-16	1P-20A			
LA-18	2P-20A	3/4"C	2#12 & 0#12N & 1#12G	AC-1 CONTROL ROOM HEAT PUMP
LA-20				
LA-22	2P-40A	3/4"C	2#8 & 1#8N & 1#10G	WATER HEATER
LA-24				
LA-26	2P-40A			
LA-28				
LA-30	1P-20A	3/4"C	1#12 & 1#12N & 1#12G	SF-1 DRY WELL SUPPLY FAN
LA-32	1P-20A	3/4"C	1#12 & 1#12N & 1#12G	EF-1 DRY WELL EXHAUST FAN
LA-34	1P-15A	3/4"C	1#12 & 0#12N & 1#12G	BATHROOM FAN
LA-36	1P-15A	3/4"C	1#12 & 0#12N & 1#12G	ODOR CONTROL SYSTEM
LA-38	1P-20A			
LA-40	1P-20A			
LA-42	1P-20A			

MCC UNIT SCHEDULE				
UNIT		TYPE	DESCRIPTION	
MCC A	1	A		
MCC A	1	C	FCB	PUMP 1 VFD
MCC A	1	G	PS	24VDC POWER SUPPLY
MCC A	1	K	MCB	MAIN CIRCUIT BREAKER
MCC A	2	A	FCB	MCC C BRANCH
MCC A	2	D	RELAY	ARC FLASH REDUCTION
MCC A	2	F		
MCC A	2	H		
MCC A	2	K	MCB	MAIN CIRCUIT BREAKER
MCC C	1	A	MLO	MAIN LUGS ONLY
MCC C	1	C	FVNR	2HP SPARE STARTER
MCC C	1	E	FCB	SPARE CIRCUIT BREAKER
MCC C	1	G	FVNR	1HP SPARE STARTER
MCC C	1	J	FCB	TRANSFORMER "TLA"
MCC C	1	L		
MCC C	2	A		
MCC C	2	C	FCB	PUMP 2 VFD
MCC C	2	G	FCB	SPARE CIRCUIT BREAKER
MCC C	2	J		
MCC C	2	L		
MCC C	3	A		
MCC C	3	C	FCB	SPARE VFD
MCC C	3	G	FVNR	SUMP PUMP
MCC C	3	J	FVNR	2HP SPARE STARTER
MCC C	3	L		
MCC C	4	A	MLO	MAIN LUGS ONLY
MCC C	4	C	FCB	TROLLEY HOIST (30A CIRCUIT BREAKER)
MCC C	4	E		
MCC C	4	G		
MCC C	4	J		
MCC C	4	L		
MCC B	1	A	FCB	MCC C BRANCH
MCC B	1	D	RELAY	ARC FLASH REDUCTION
MCC B	1	F		
MCC B	1	H		
MCC B	1	K	MCB	MAIN CIRCUIT BREAKER
MCC B	2	A		
MCC B	2	C	FCB	PUMP 3 VFD
MCC B	2	G	PS	24VDC POWER SUPPLY
MCC B	2	K	MCB	MAIN CIRCUIT BREAKER

**Call 48 Hours Before You Dig**  
1-800-424-5555  
UNDERGROUND SERVICE

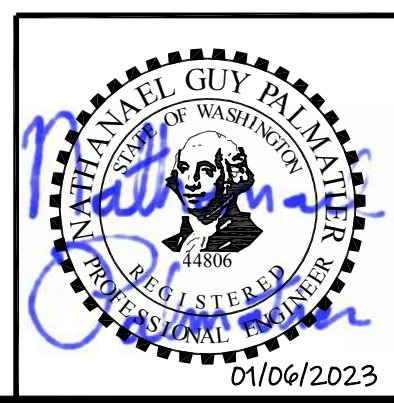

No.	Revision	Date	By	App'd
	ISSUED FOR BID	01-2023	TF	RAD

**bhc CONSULTANTS**  
BHC Consultants, LLC  
1601 Fifth Avenue, Suite 500  
Seattle, Washington 98101  
206.505.3400  
206.505.3406 (fax)  
www.bhcconsultants.com

Designed: N. Palmatier, P.E.  
Drawn: G. Castillo  
Checked: R. Dorn, P.E.

Scale: NTS  
One Inch at Full Scale  
If Not One Inch Scale Accordingly

**Kitsap County Public Works**  
614 Division Street, MS 26  
Port Orchard, WA 98366

**SILVERDALE CONVEYANCE SYSTEM AND PUMP STATION 4 UPGRADES SCHEDULE C**

**LOAD CALCULATIONS AND SCHEDULES**

Drawing: **E-28C**  
Sheet: **114** of **117**  
File: P21-10530\_E-28C  
Date: January 2023

Path: S:\Cadd\Kitsap County\21-10530 Silverdale Convey-PS 4 Uprgr\Design\Drawings\21-10530\_E-29C\_Plot.dwg Plot date: Jan 06, 2023 12:06:26pm CAD User: soisec  
 Xref Filename: 21-10530\_TB | Palmatier | Dan | Fisher |

PROGRAMMABLE LOGIC CONTROLLER INPUT AND OUTPUT SCHEDULES				
RACK	SLOT	CHANNEL	TYPE	DESCRIPTION
2	1	0	DO	PUMP 1 CALL TO RUN
2	1	1	DO	PUMP 2 CALL TO RUN
2	1	2	DO	PUMP 1 FAULT (LIGHT)
2	1	3	DO	PUMP 2 FAULT (LIGHT)
2	1	4	DO	PUMP 1 RESET
2	1	5	DO	PUMP 2 RESET
2	1	6	DO	
2	1	7	DO	
2	1	8	DO	
2	1	9	DO	ALARM LIGHT
2	1	10	DO	ALARM HORN
2	1	11	DO	NFPA 820 FAULT
2	1	12	DO	GAS OK
2	1	13	DO	SPARE
2	1	14	DO	SPARE
2	1	15	DO	
2	2	0	DO	PLC FAIL
2	2	1	DO	PUMP 3 CALL TO RUN
2	2	2	DO	
2	2	3	DO	PUMP 3 FAULT (LIGHT)
2	2	4	DO	
2	2	5	DO	PUMP 3 RESET
2	2	6	DO	
2	2	7	DO	
2	2	8	DO	
2	2	9	DO	
2	2	10	DO	
2	2	11	DO	
2	2	12	DO	
2	2	13	DO	
2	2	14	DO	
2	2	15	DO	
2	3	0	DI	INTRUSION ENABLE (NOT LABELED)
2	3	1	DI	ALARM RESET / ACKNOWLEDGE
2	3	2	DI	DIESEL ENGINE GENERATOR RUNNING
2	3	3	DI	DIESEL ENGINE GENERATOR WARNING
2	3	4	DI	DIESEL ENGINE GENERATOR FAULT/SHUTDOWN
2	3	5	DI	DIESEL ENGINE GENERATOR LOW FUEL
2	3	6	DI	DIESEL ENGINE GENERATOR FUEL LEAK
2	3	7	DI	DIESEL ENGINE GENERATOR PANEL OPEN
2	3	8	DI	FM1 FLOW PULSE
2	3	9	DI	BUILDING SUMP PUMP WET WELL FLOAT ONLY MODE
2	3	10	DI	BUILDING SUMP PUMP WET WELL HIGH HIGH LEVEL
2	3	11	DI	BACKUP FLOAT CONTROL PANEL HIGH LEVEL
2	3	12	DI	BUILDING SUMP PUMP WET WELL LOW LEVEL
2	3	13	DI	BUILDING SUMP PUMP WET WELL LOW LOW LEVEL
2	3	14	DI	PARTICULATE DETECTOR ALARM
2	3	15	DI	
2	4	0	DI	PUMP 1 VFD OPERATING
2	4	1	DI	PUMP 1 VFD FAULTED
2	4	2	DI	PUMP 1 VFD READY
2	4	3	DI	PUMP 1 HARMONIC LINE FILTER HIGH TEMPERATURE ALARM
2	4	4	DI	PUMP 1 VFD LOAD FILTER HIGH TEMPERATURE ALARM
2	4	5	DI	PUMP 1 VFD/MOTOR MONITOR RESET
2	4	6	DI	PUMP 1 HIGH TEMPERATURE ALARM
2	4	7	DI	PUMP 1 LEAK SEAL ALARM
2	4	8	DI	PUMP 1 CALL TO RUN
2	4	9	DI	PUMP 1 HOA IN AUTO
2	4	10	DI	PUMP1 HOA IN HAND
2	4	11	DI	PUMP1 HOA IN AUTO
2	4	12	DI	PUMP 1 HOA IN HAND
2	4	13	DI	PUMP 1 LINE FILTER CONTACTOR ENABLE
2	4	14	DI	

PROGRAMMABLE LOGIC CONTROLLER INPUT AND OUTPUT SCHEDULES				
RACK	SLOT	CHANNEL	TYPE	DESCRIPTION
2	5	0	DI	PUMP 2 VFD OPERATING
2	5	1	DI	PUMP 2 VFD FAULTED
2	5	2	DI	PUMP 2 VFD READY
2	5	3	DI	PUMP 2 HARMONIC LINE FILTER HIGH TEMPERATURE ALARM
2	5	4	DI	PUMP 2 VFD LOAD FILTER HIGH TEMPERATURE ALARM
2	5	5	DI	PUMP 2 VFD / MOTOR MONITOR RESET
2	5	6	DI	PUMP 2 HIGH TEMPERATURE ALARM
2	5	7	DI	PUMP 2 LEAK SEAL ALARM
2	5	8	DI	PUMP 2 START LEVEL FLOAT
2	5	9	DI	PUMP 2 STOP LEVEL FLOAT
2	5	10	DI	PUMP 2 RUN ON FLOATS
2	5	11	DI	PUMP 2 HOA IN AUTO
2	5	12	DI	PUMP 2 HOA IN HAND
2	5	13	DI	PUMP 2 LINE FILTER CONTACTOR ENABLE
2	5	14	DI	
2	5	15	DI	
2	6	0	DI	PUMP 3 VFD OPERATING
2	6	1	DI	PUMP 3 VFD FAULTED
2	6	2	DI	PUMP 3 VFD READY
2	6	3	DI	PUMP 3 HARMONIC LINE FILTER HIGH TEMPERATURE ALARM
2	6	4	DI	PUMP 3 VFD LOAD FILTER HIGH TEMPERATURE ALARM
2	6	5	DI	PUMP 3 VFD / MOTOR MONITOR RESET
2	6	6	DI	PUMP 3 HIGH TEMPERATURE ALARM
2	6	7	DI	PUMP 3 LEAK SEAL ALARM
2	6	8	DI	PUMP 3 START LEVEL FLOAT
2	6	9	DI	PUMP 3 STOP LEVEL FLOAT
2	6	10	DI	PUMP 3 RUN ON FLOATS
2	6	11	DI	PUMP 3 HOA IN AUTO
2	6	12	DI	PUMP 3 HOA IN HAND
2	6	13	DI	PUMP 3 LINE FILTER CONTACTOR ENABLE
2	6	14	DI	
2	6	15	DI	
2	7	0	DI	PS1CON PS A IN USE
2	7	1	DI	PS2CON PS B IN USE
2	7	2	DI	UPS ON BATTERY POWER
2	7	3	DI	UPS READY / NOT FAULT
2	7	4	DI	
2	7	5	DI	
2	7	6	DI	CONTROL ROOM - MAIN DOOR OPEN
2	7	7	DI	CONTROL ROOM - SIDE DOOR OPEN
2	7	8	DI	SERVICE SWITCHBOARD SURGE PROTECTIVE DEVICE ALARM
2	7	9	DI	SERVICE SWITCHBOARD SPD CIRCUIT BREAKER CLOSED (OK)
2	7	10	DI	SERVICE SWITCHBOARD ATS A CIRCUIT BREAKER CLOSED (OK)
2	7	11	DI	SERVICE SWITCHBOARD ATS B CIRCUIT BREAKER CLOSED (OK)
2	7	12	DI	MCC A MAIN CIRCUIT BREAKER CLOSED (OK)
2	7	13	DI	MCC A ROLL UP GENERATOR FEEDER CIRCUIT BREAKER (OK)
2	7	14	DI	MCC A VFD PUMP 1 CIRCUIT BREAKER CLOSED (OK)
2	7	15	DI	MCC A MCC A TO MCC C TIE BREAKER CLOSED (OK)
2	8	0	DI	MCC B MAIN CIRCUIT BREAKER CLOSED (OK)
2	8	1	DI	MCC B ROLL UP GENERATOR FEEDER CIRCUIT BREAKER (OK)
2	8	2	DI	MCC B VFD PUMP 3 CIRCUIT BREAKER CLOSED (OK)
2	8	3	DI	MCC B MCC B TO MCC C TIE BREAKER CLOSED (OK)
2	8	4	DI	MCC C SPARE FVNR START MCP CLOSED (OK)
2	8	5	DI	MCC C VFD PUMP 3 CIRCUIT BREAKER CLOSED (OK)
2	8	6	DI	MCC C SUMP PUMP START MCP CLOSED (OK)
2	8	7	DI	MCC C TRANSFORMER TLA CIRCUIT BREAKER CLOSED (OK)
2	8	8	DI	ATS A NORMAL POWER AVAILABLE
2	8	9	DI	ATS A NORMAL POWER CONNECTED
2	8	10	DI	ATS A SECONDARY POWER AVAILABLE
2	8	11	DI	ATS A SECONDARY POWER CONNECTED
2	8	12	DI	ATS B NORMAL POWER AVAILABLE
2	8	13	DI	ATS B NORMAL POWER CONNECTED
2	8	14	DI	ATS B SECONDARY POWER AVAILABLE
2	8	15	DI	ATS B SECONDARY POWER CONNECTED

PROGRAMMABLE LOGIC CONTROLLER INPUT AND OUTPUT SCHEDULES				
RACK	SLOT	CHANNEL	TYPE	DESCRIPTION
2	9	0	DI	MCC A ARC FLASH REDUCTION MAINTENANCE MODE
2	9	1	DI	MCC B ARC FLASH REDUCTION MAINTENANCE MODE
2	9	2	DI	PUMP 1 SELECTED LEAD
2	9	3	DI	PUMP 2 SELECTED LEAD
2	9	4	DI	PUMP 3 SELECTED LEAD
2	9	5	DI	PUMP 1 SELECTED LAG
2	9	6	DI	PUMP 2 SELECTED LAG
2	9	7	DI	PUMP 3 SELECTED LAG
2	9	8	DI	SUPPLY FAN AIR FLOW OK
2	9	9	DI	EXHAUST FAN AIR FLOW OK
2	9	10	DI	NFPA 820 ENVIRONMENT ALARM SILENCED
2	9	11	DI	SUPPLY FAN MOTOR CONTROL IN ON
2	9	12	DI	EXHAUST FAN OOR IN ON
2	9	13	DI	EXHAUST FAN OOR IN REMOTE
2	9	14	DI	
2	9	15	DI	

PROGRAMMABLE LOGIC CONTROLLER INPUT AND OUTPUT SCHEDULES					
RACK	SLOT	CHANNEL	TYPE	DESCRIPTION	RANGE
1	3	0	AI	SUBMERSIBLE LEVEL (PRESSURE) TRANSMITTER	0 FT - 15 FT, 4 mA - 20 mA
1	3	1	AI	FORCE MAIN PRESSURE	0 PSI - 100 PSI, 4 mA - 20 mA
1	3	2	AI	FORCE MAIN FLOW METER	0 GPM - 1000 GPM, 4 mA - 20 mA
1	3	3	AI	PUMP1 POWER FEEDBACK	0% - 100%, 4 mA - 20 mA
1	4	0	AI	PUMP 2 POWER FEEDBACK	50% - 100%, 4 mA - 20 mA
1	4	1	AI	PUMP 3 POWER FEEDBACK	50% - 100%, 4 mA - 20 mA
1	4	2	AI	CONTROL PANEL TEMPERATURE	0°F - 150°F, 4 mA - 20 mA
1	4	3	AI	CONTROL PANEL TEMPERATURE	0°F - 150°F, 4 mA - 20 mA
1	5	0	AI	ENGINE GENERATOR FUEL LEVEL	0% - 100%, 4 mA - 20 mA
1	5	1	AI		0% - 100%, 4 mA - 20 mA
1	5	2	AI		0% - 100%, 4 mA - 20 mA
1	5	3	AI		0% - 100%, 4 mA - 20 mA
1	1	0	AO	PUMP 1 SPEED REF	MIN - MAX, 4 mA - 20 mA
1	1	1	AO	PUMP 2 SPEED REF	MIN - MAX, 4 mA - 20 mA
1	1	2	AO		- , 4 mA - 20 mA
1	1	3	AO		- , 4 mA - 20 mA
1	1	0	AO	PUMP 3 SPEED REF	- , 4 mA - 20 mA
1	1	1	AO		- , 4 mA - 20 mA
1	1	2	AO		- , 4 mA - 20 mA
1	1	3	AO		- , 4 mA - 20 mA

**Call 48 Hours Before You Dig**  
 1-800-424-5555  
 UNDERGROUND SERVICE

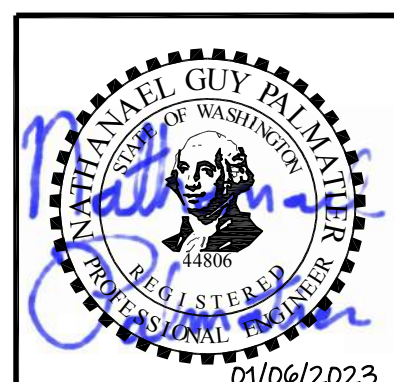

01/06/2023

No.	Revision	Date	By	App'd
		01-2023	TF	RAD
	ISSUED FOR BID			



**BHC Consultants, LLC**  
 1601 Fifth Avenue, Suite 500  
 Seattle, Washington 98101  
 206.505.3400  
 206.505.3406 (fax)  
 www.bhcconsultants.com

Designed: N. Palmatier, P.E.  
 Drawn: A. Bradley  
 Checked: R. Dorn, P.E.

Scale:  
 NTS  
 One Inch at Full Scale  
 If Not One Inch Scale Accordingly



**Kitsap County Public Works**  
 614 Division Street, MS 26  
 Port Orchard, WA 98366

**SILVERDALE CONVEYANCE SYSTEM AND PUMP STATION 4 UPGRADES**  
 SCHEDULE C  
**ELECTRICAL SCHEDULES**  
**1 OF 2**

Drawing: **E-29C**  
 Sheet: **115** of **117**  
 File: P21-10530\_E-29C  
 Date: January 2023

CIRCUIT SCHEDULES POWER CIRCUITS

TAG	CONDUIT	CONDUCTORS	FROM	TO
U1	2-4"	CONDUCTORS BY UTILITY	UTILITY PRIMARY POLE	UTILITY TRANSFORMER
U2	4-4"	3 SETS EACH 3-600KCMIL & 1-300KCMIL(N)	UTILITY TRANSFORMER	UTILITY METER SWITCHBOARD
1	--	--	UTILITY METERING	UTILITY METER SWITCHBOARD
2	2-4"	2 SETS EACH 3-600KCMIL & 1-300KCMIL(N) & 1-1/0(G)	UTILITY METER SWITCHBOARD	ATS A
			UTILITY METER SWITCHBOARD	ATS B
			ENGINE GENERATOR PACKAGE	ATS A
			ENGINE GENERATOR PACKAGE	ATS B
			ATS A	MCC A
			ATS B	MCC B
			MCC C	MCC A
			MCC C	MCC B
3	2-2"	2 SETS EACH 3/0VFD (MIN BEND RADIUS 19")	MCC A	VFD PUMP 1
			MCC B	VFD PUMP 2
			MCC C	VFD PUMP 3
4	2-2"	2 SETS EACH 3/0VFD (MIN BEND RADIUS 19")	VFD PUMP 1	MOTOR TERMINAL JUNCTION BOX PUMP 1
			VFD PUMP 2	MOTOR TERMINAL JUNCTION BOX PUMP 2
			VFD PUMP 3	MOTOR TERMINAL JUNCTION BOX PUMP 3
5	2-4"	2 SETS EACH MNF (MIN BEND RADIUS 19")	MOTOR TERMINAL JUNCTION BOX PUMP 1	SUBMERSIBLE PUMP 1
			MOTOR TERMINAL JUNCTION BOX PUMP 2	SUBMERSIBLE PUMP 2
			MOTOR TERMINAL JUNCTION BOX PUMP 3	SUBMERSIBLE PUMP 3
6	2-3"	2 SETS EACH 3#3/0 & 1#3/0N & 1#3G	GENERATOR INLET RECEPTACLE PANEL	MCC A
			GENERATOR INLET RECEPTACLE PANEL	MCC B
7	1-1/4"	3#4 & 1#8G	MCC C	TLA
8	2-1/2"	3#1 & 1#1N & 1#6G	TLA	TLACB
			TLACB	LA (SECTION 1)
			LA (SECTION 1)	LA (SECTION 2)
9	1"	3#10 & 2#14 & 1#10G	MCC C	ODOR CONTROL FAN
10	3/4"	1#10 & 2#14 & 1#10G	MCC C	SUPPLY FAN (SF-1)
			MCC C	EXHAUST FAN (EF-1)

MOTOR SCHEDULE

	HP	EFFICIENCY	LRC	FLA	VOLTAGE	PHASE	NOTES/WSEC EXCEPTION
EF-1	0.75	85%	50. A	8.8 A	115 V	1	ELECTRICALLY COMMUTATED
SF-1	0.75	85%	50. A	8.8 A	115 V	1	ELECTRICALLY COMMUTATED
PUMP 1	250	93.50%	2030. A	284. A	480 V	3	C405.8 EXCEPTION: SUBMERSIBLE ELECTRIC MOTOR
PUMP 2	250	94%	2030. A	284. A	480 V	3	C405.8 EXCEPTION: SUBMERSIBLE ELECTRIC MOTOR
PUMP 3	250	94%	2030. A	284. A	480 V	3	C405.8 EXCEPTION: SUBMERSIBLE ELECTRIC MOTOR
ODOR CONTROL FAN	3	89.50%	32. A	4.8 A	480 V	3	

TRANSFORMER SCHEDULE

	PRIMARY VOLTAGE	SECONDARY VOLTAGE	SIZE [KVA]	EFFICIENCY	NOTES/WSEC EXCEPTION
TLA	480V, 3PH, DELTA	208V/120Y, 3PH, WYE	45	98.40% MIN	

WASHINGTON STATE ENERGY COMPLIANCE FORM  
LIGHTING COMPLIANCE SUMMARY

2018 WSEC Compliance Form for Commercial Buildings including Group R2, R7A, R8 over 3 stories and all R1. Administered by: ©2022 NECA. All rights reserved.

**Project Title:** Silverdale LIB Station 4 Upgrades - 2018 WSEC  
**Project Address:** 9606 Fredrickson RD NW, Silverdale, WA 98131  
**Project Date:** Jun 01, 2022

**Project & Applicant Information:**  
**Applicant Name:** National Fabricator  
**Applicant Phone:** 360-557-9954  
**Applicant Email:** national@nationalfabricator.com

**General Occupancy:** All Commercial  
**General Building Use Type:** Utility/Shop/Other  
**Building Const. Floor Area:** 1,439  
**Project Const. Floor Area:** 1,439

**Lighting Project Description:** Revised pump station control building to support wastewater pumping improvements. Plans are attached.

**Lighting Compliance Scope and Method:** Project Type: New Building or Addition; Lighting Scope: Interior Lighting; Compliance Method: Space by space; LPA Calculation Adjustment: None; Compliance Verification: COMPLETES

**Lighting Power Calculation - NEW BUILDING - INTERIOR LIGHTING**  
 Compliance Method: Space by space; LPA Calculation Adjustment: None; Compliance Verification: COMPLETES

General Space Type	Specific Space Type	Ceiling Height (ft)	Gross Interior Area (SF)	LPA (Watts/SF)	Total Watts Allowed (GFA x LPA x U)	Total Proposed Watts (LPA x Interior LPA)	Compliance Status
Electrical/mechanical			700	0.43	301		
Electrical/mechanical			100	0.43	43		
Electrical	General		88	0.43	38		
Electrical	General		88	0.20	18		
<b>Total:</b>					<b>641</b>	<b>387</b>	<b>COMPLETES</b>

**Proposed Lighting Power Density**

Fixture Type	Fixture ID	Quantity of Fixtures (QF)	Watts per Fixture (WpF)	Total Linear Foot (LF)	Watts per Linear Foot (WpLF)	Total Watts Proposed (QF x WpF) or (LF x WpLF)
Individual Fixtures						
Horizontal surface-mount	A21	3	30			90
Horizontal surface-mount	A40	13	30			390
Wall-mounted	C	1	10			10
<b>Proposed Total LPA:</b>						<b>567</b>

**Project Title:** Silverdale LIB Station 4 Upgrades - 2018 WSEC  
**Date:** Jun 01, 2022

**Proposed Fixtures Details - NEW BUILDING - INTERIOR LIGHTING**  
 Compliance Verification: COMPLETES

Fixture Type/Application	Fixture ID	Location in Drawings	Lamp Type	Watts or Existing in Room
Individual Fixtures				
Horizontal surface-mount	A21	E-3	LED	New
Fixture Description: 2P Linear LED fixture, 4000K light, scullie lens. Are these fixtures located within a daylight area? No				
Do these fixtures require specific application lighting controls? None required				
Horizontal surface-mount	A40	E-7 and E-4	LED	New
Fixture Description: 4P Linear LED fixture, 4000K light, scullie lens. Are these fixtures located within a daylight area? No				
Do these fixtures require specific application lighting controls? None required				
Wall-mounted	C	E-3	LED	New
Fixture Description: Overhead Vanity Light. Are these fixtures located within a daylight area? No				
Do these fixtures require specific application lighting controls? None required				

**Project Title:** Silverdale LIB Station 4 Upgrades - 2018 WSEC  
**Date:** Jun 01, 2022

**Lighting Power Calculation - NEW BUILDING - EXTERIOR LIGHTING**  
 Compliance Verification: COMPLETES

**Exterior Lighting Zone:** ZONE 2; New Site Allowance: 400

Treatable Surface	Treatable Surface Sub-Type	Surface Area (SF)	LPA (Watts/SF)	Linear Foot (LF)	LPA (Watts/LF)	Total Watts Allowed (LPA x SF) or (LPA x LF)	Total Treatable Proposed Watts	Treatable Compliance Status
Building entrance and exits		170	0	14		0		
Uncovered parking areas and drives	Production entrances & exits	5721	0.04			189		
<b>New Site Allowance:</b>						<b>400</b>	<b>522</b>	<b>COMPLETES</b>

**Proposed Treatable Lighting Power Density**

Fixture Type	Fixture ID	Treatable Surface Type	Quantity of Fixtures (QF)	Watts per Fixture (WpF)	Total Linear Foot (LF)	Watts per Linear Foot (WpLF)	Total Watts Proposed (QF x WpF) or (LF x WpLF)
Individual Fixtures							
Face light	FF	Building entrances and exits - Production entrances & exits	3	21			63
Wall-mounted	WB	Uncovered parking areas and drives -	2	133			266
Wall-mounted	GG	Building entrances and exits - Production entrances & exits	1	28			28
<b>Treatable Proposed Total:</b>							<b>357</b>

Call 48 Hours Before You Dig  
1-800-424-5555  
UNDERGROUND SERVICE

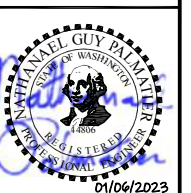

Path: S:\Cadd\Kitsap County\21-10530 Silverdale Conveyance\PS 4 Upgrades\Design\Drawings\21-10530\_E-300\_Plot.dwg; Plot date: Mar 20, 2023 03:31:49 pm; CAD User: solsoe; Xref Filename: | X21-10530\_TB | Palmatier | Dahl | Fisher |

No.	Revision	Date	By	App'd
	ISSUED FOR BID	01-2023	TF	RAD

**bhc CONSULTANTS**  
 BHC Consultants, LLC  
 1601 Fifth Avenue, Suite 500  
 Seattle, Washington 98101  
 206.505.3400  
 206.505.3406 (fax)  
 www.bhcconsultants.com

Designed: N. Palmatier, P.E.  
 Drawn: A. Bradley  
 Checked: R. Dorn, P.E.

Scale: NTS  
 One Inch at Full Scale  
 If Not One Inch Scale Accordingly



**Kitsap County Public Works**  
 614 Division Street, MS 26  
 Port Orchard, WA 98366

**SILVERDALE CONVEYANCE SYSTEM AND PUMP STATION 4 UPGRADES SCHEDULE C**  
**ELECTRICAL SCHEDULES**  
**2 OF 2**

Drawing: E-30C  
 Sheet: 116 of 117  
 File: P21-10530\_E-30C  
 Date: January 2023

Path: S:\Card\Kitsap County\21-10530 Silverdale Conveyance-PS 4 Upgr\Design\Drawings\21-10530\_E-31C\_Plot.dwg Plot date: Jan 06, 2023 12:16:44pm CAD User: solsoe  
 Xref Filename: 21-10530\_TB | Palmatier | 21-10530-PS4\_Ext Topo | 21-10530-PS4\_Prop HMA | 21-10530-PS4\_Prop Site | Danil | Fisher |

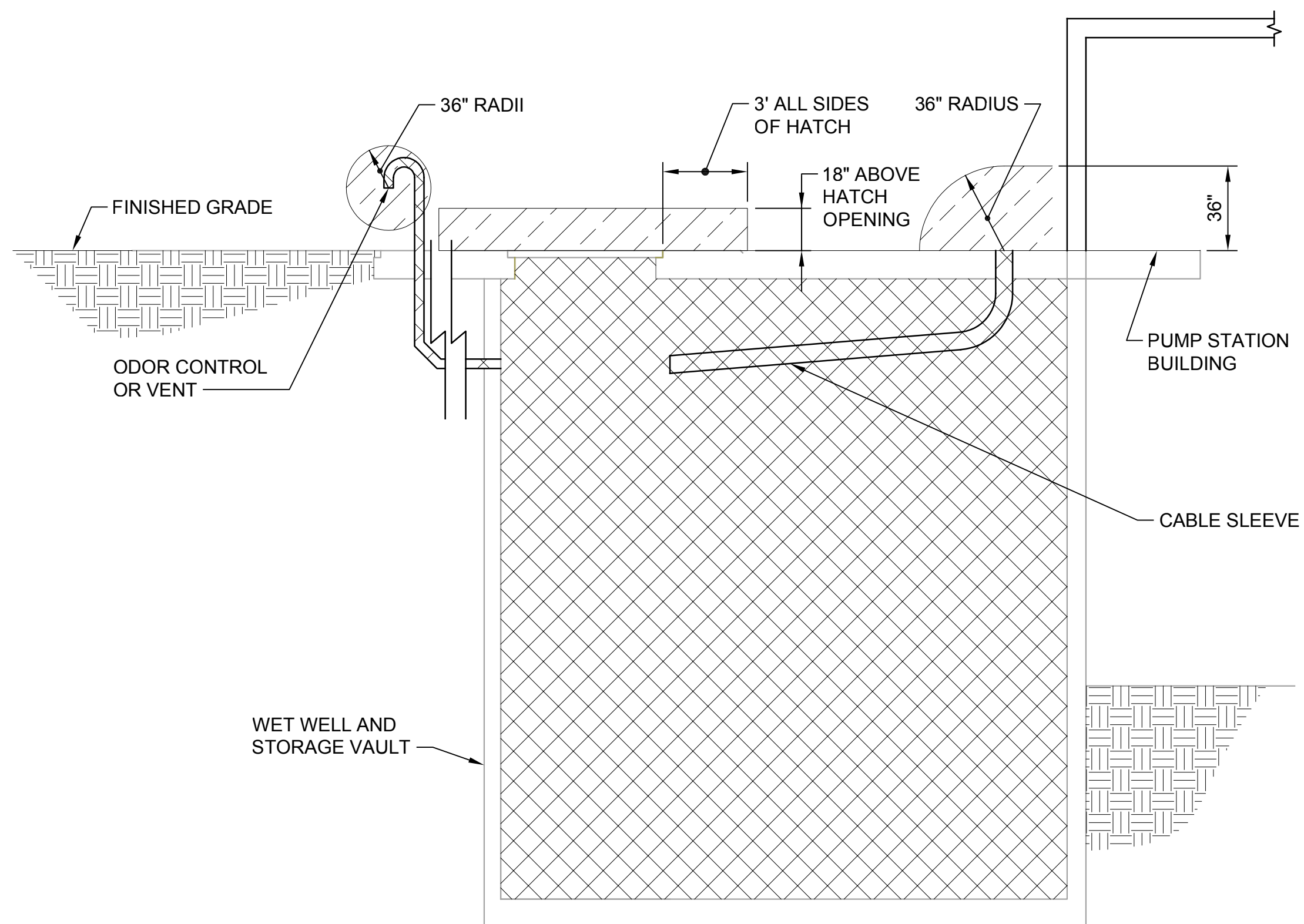

- LEGEND:**
- CLASS 1, DIV 1
  - CLASS 1, DIV 2

AREA CLASSIFICATION TABLE			
	NFPA 820 CLASSIFICATION	REQUIRED VENTILATION	REQUIRED PRESSURE DIFFERENTIAL
WET WELL	CLASS I DIVISION 1	N/A	N/A
PUMP STATION BUILDING	UNCLASSIFIED	N/A	N/A
OVERFLOW STORAGE VAULT	CLASS 1 DIVISION 1	N/A	N/A
VALVE ROOM	UNCLASSIFIED	6 ACH	+0.1 IN H2O
ODOR CONTROL (WITHIN 36 INCHES)	CLASS I DIVISION 2	N/A	N/A

N/A NOT APPLICABLE  
 ACH AIR CHANGES PER HOUR  
 IN H2O INCHES OF WATER PRESSURE

**HAZARDOUS AREA CLASSIFICATION  
 DETAIL**

NTS 1 TYP

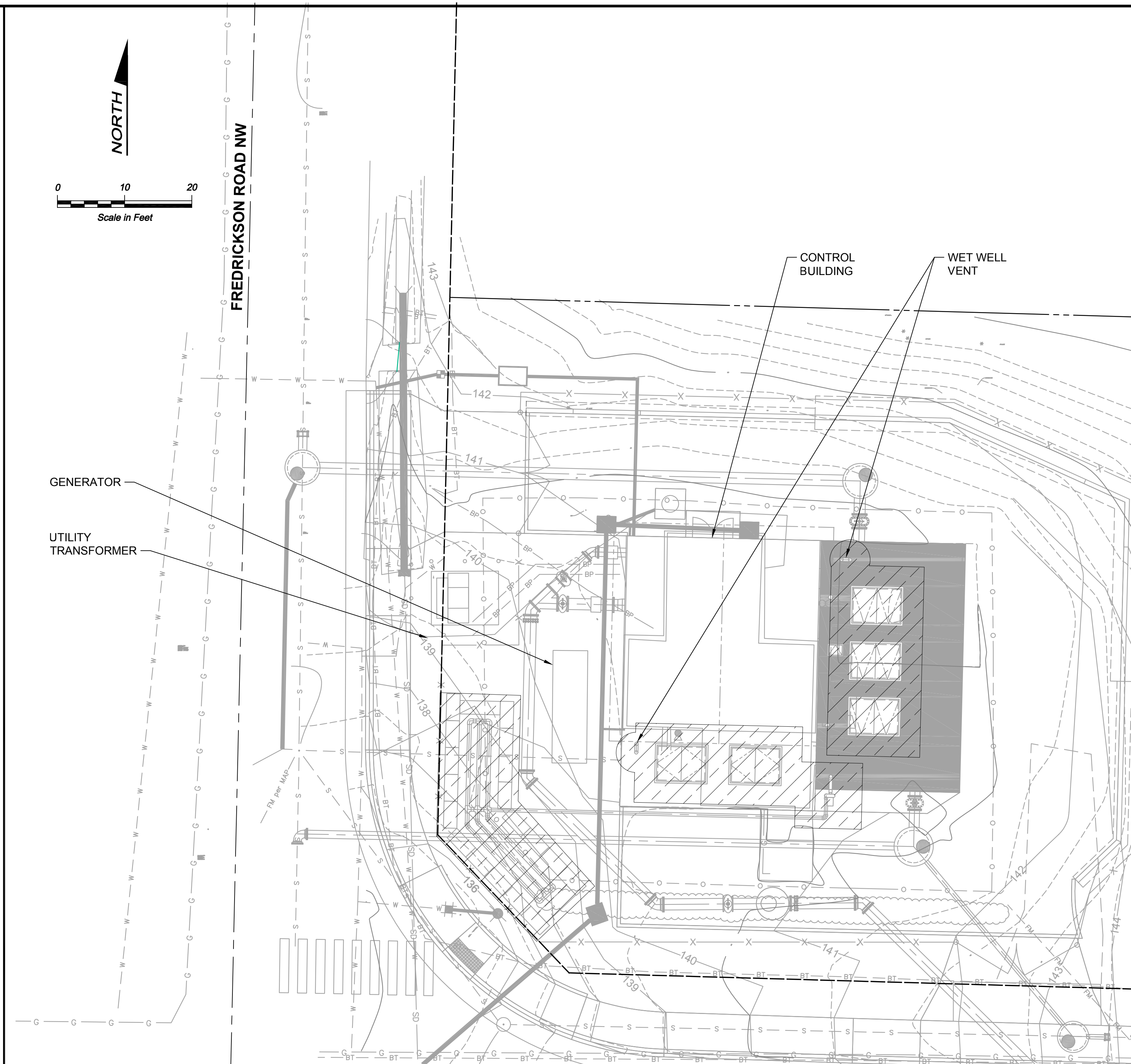

- LEGEND:**
- CLASS 1, DIV 1
  - CLASS 1, DIV 2

**HAZARDOUS AREA CLASSIFICATION  
 DETAIL**

SCALE: 1" = 10'-0" 2

**Call 48 Hours  
 Before You Dig**  
 1-800-424-5555  
 UNDERGROUND SERVICE

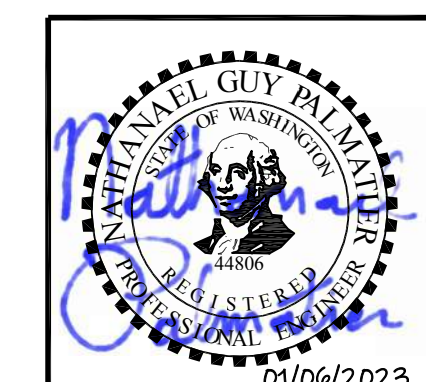

**bhc**  
 CONSULTANTS

**BHC Consultants, LLC**  
 1601 Fifth Avenue, Suite 500  
 Seattle, Washington 98101  
 206.505.3400  
 206.505.3406 (fax)  
 www.bhcconsultants.com

Designed: N. Palmatier, P.E.  
 Drawn: J. Lira  
 Checked: R. Dorn, P.E.

Scale:  
 As Shown  
 One Inch at Full Scale  
 If Not One Inch Scale Accordingly



**Kitsap County Public Works**  
 614 Division Street, MS 26  
 Port Orchard, WA 98366

**SILVERDALE CONVEYANCE SYSTEM AND PUMP STATION 4 UPGRADES  
 SCHEDULE C**

**HAZARDOUS AREA CLASSIFICATION**

Drawing: **E-31C**  
 Sheet: **117** of **117**  
 File: P21-10530\_E-31C  
 Date: January 2023

