

000 91 13.2 – ADDENDUM NO. 2

1.1 PROJECT INFORMATION

- A. Project Name: Pacific Building Conversion
- B. Owner: Kitsap County Department of Human Services
- C. Architect: Rice Fergus Miller, Inc.
- D. Architect Project Number: 2021056.01
- E. Date of Addendum: November 29, 2023

1.2 NOTICE TO BIDDERS

- A. This Addendum is issued to all registered plan holders pursuant to the instructions to Bidders and Conditions of the Contract. This Addendum serves to clarify, revise, and supersede information in the Project Manual, Drawings, and any previously issued Addenda. Portions of the Addendum affecting the Contract Documents will be incorporated into the Contract by enumeration of the Addendum in the Owner/Contractor Agreement.
- B. The Bidder shall acknowledge receipt of this Addendum in the appropriate space on the Bid Form.
- C. The date for receipt of bids is unchanged by this Addendum at same time and location.
 - 1. Bid Date: December 6, 2023, 2:00PM
- D. This Addendum is in response to bidder questions and substitution requests.
- E. All work shall be substantially complete by November 2nd, 2024, with intent to have the shelter open and operational by the fall and winter months.
- F. Liquidated Damages –
 - 1. Any delay to this Project could have substantial impact upon and cause significant damages to the Owner. The Owner will assess, and the Contractor will be responsible for, liquidated damages in the amount of \$500.00 per day for each calendar day beyond the Contract Time that Substantial Completion is not timely achieved.
 - 2. The Contractor and Owner agree that the liquidated damages amount is not a penalty and is a reasonable estimation of actual damages to the Owner, as of this date of Agreement, based on the inherent uncertainty and difficulty in calculating and quantifying damages caused by delays in the construction of public facilities.
- G. Comply with RCW 49.28.065 “Public Works employees – Agreements to work ten hour day.”
- H. Telephone and Data System shall be Owner-supplied.
- I. Entry Access Security System shall be Owner-supplied.

1.3 PROJECT MANUAL ITEMS

- ITEM 1. Specification Section 000 01 10 – REPLACE in its entirety.
 - a. Revise Table of Contents:
 - i. Remove Section 01 22 00 in its entirety.
 - ii. Remove Section 32 92 23 in its entirety.
- ITEM 2. Specification Section 000 21 13-2 – REPLACE sheet.
 - a. Remove Paragraph 1.1.N.
- ITEM 3. Specification Section 000 21 13-7 – REPLACE sheet.
 - a. Remove Paragraph 1.4.A.5.
- ITEM 4. Specification Section 000 21 13-13 – REPLACE sheet.
 - a. Remove Paragraph 1.6.A.2.Consideration.c.
- ITEM 5. Specification Section 01 22 00 – REMOVE section in its entirety.
- ITEM 6. Specification Section 01 29 00-4 – REPLACE sheet.
 - a. Remove Paragraph 1.5.L.6.
- ITEM 7. Specification Section 01 41 00-1 – REPLACE sheet.
 - a. Remove Paragraphs 1.1.C and 1.4.C. in its entirety.
 - b. Comply with local building codes for the area having jurisdiction.
- ITEM 8. Specification Section 01 41 00-2 – REMOVE sheet.
 - a. Comply with local building codes for the area having jurisdiction.
- ITEM 9. Specification Section 01 74 19-2 – REPLACE sheet.
 - a. Remove Paragraph 3.2.F.
- ITEM 10. Specification Section 01 78 36-2 – REPLACE sheet.
 - a. Warranties shall begin on the date of Substantial Completion of the Work.
- ITEM 11. Specification Section 01 91 13-1 – REPLACE sheet.
 - a. The mechanical contractor shall employ an independent Commissioning Agent
- ITEM 12. Specification Section 02 41 19-3 – REPLACE sheet.
 - a. Remove Paragraph 3.8.B.1.

- ITEM 13. Specification Section 07 31 13-2 – REPLACE sheet.
 - a. Revised Paragraph 2.3.B.1.
 - b. Revised Paragraph 2.3.B.2.a.
- ITEM 14. Specification Section 08 33 13-1 – REPLACE sheet.
 - a. Paragraph 2.2.A – Revise “Dotor” to “Door”
 - b. Paragraph 2.2.C – Revise “Face of wall” to “Between jamb”
- ITEM 15. Specification Section 11 40 00 – REPLACE in its entirety.
 - a. Foodservice equipment updated.
- ITEM 16. Specification Section 23 34 00 – REPLACE in its entirety.
 - a. Fans manufacturers updated.
- ITEM 17. Specification Section 23 38 00 – REPLACE in its entirety.
 - a. Hood manufacturers updated.
- ITEM 18. Specification Section 23 74 23 – REPLACE in its entirety.
 - a. MAU manufacturers updated.
- ITEM 19. Specification Section 27 00 00-1 – REPLACE sheet.
 - a. Remove date “August 25, 2023” from Paragraph 3.1.D.
- ITEM 20. Specification Section 32 92 23 – REMOVE in its entirety.
 - a. There is no sod in the project.
- ITEM 21. Specification Section 33 11 16 – REPLACE in its entirety.
 - a. Site Water Distribution specification has been revised to West Sound Utility District.
- ITEM 22. Specification Section 33 31 00 – REPLACE in its entirety.
 - a. Sanitary Sewer Systems specification has been revised to West Sound Utility District.

1.4 DRAWINGS

- ITEM 1. Sheet C3.00 – REPLACE in its entirety:
 - a. Removed “4” from bike rack note. The bike rack is existing.
- ITEM 2. Sheet C5.00 – REPLACE in its entirety:
 - a. Added notes indicating new roof drains, downspouts, and roof drain systems.
- ITEM 3. Sheet A00.01 – REPLACE in its entirety:
 - a. Revised project team contact information.

- ITEM 4. Sheet A11.01 – REPLACE in its entirety:
- a. Removed “4” from SITE-7 bicycle covered shelter note. The bike rack is existing.
- ITEM 5. Sheet A21.01 – REPLACE in its entirety:
- a. Added floor sinks in Kitchen.
- ITEM 6. Sheet A25.01 – REPLACE in its entirety:
- a. Revised roof walkway pad layout.
- ITEM 7. Sheet A26.02 – REPLACE in its entirety:
- a. Added Keynote 4 to rated wall assembly.
 - b. Kitchen Equipment Schedule:
 - i. Removed Manufacturer and Model columns.
 - ii. Revised Equipment 10 to owner furnished and contractor installed.
 - iii. Revised Equipment 23 to Phase 1 scope of work.
 - iv. Removed Equipment 34.
 - v. Renamed Equipment 27 to 28.
- ITEM 8. Sheet A34.01 – REPLACE in its entirety:
- a. Revised Detail 6 – Revised Item 38 wall guard.
 - b. Revised Detail 7
 - i. Revised Item 38 wall guard.
 - ii. Removed Item 39 countertop from Door 115C.
 - iii. Revised sill height of Doors 115C, 115D, and 115E.
- ITEM 9. Sheet A60.01 – REPLACE in its entirety:
- a. Revised Details 1, 2, and 5 to reflect shortened countertop and between jamb mounted coiling counter door.
- ITEM 10. Sheet A72.01 – REPLACE in its entirety:
- a. Revised Detail 6 to show between jamb mounted coiling counter door and added header detail callout.
- ITEM 11. Sheet M00.03 – REPLACE in its entirety:
- a. Fan, MAU, Hood schedule notes added.
- ITEM 12. Sheet M00.04 – REPLACE in its entirety:
- a. ERV schedule note A updated. Split-System schedule note 1 update, note C added.5

- ITEM 13. Sheet M22.01 – REPLACE in its entirety:
- a. RTU-1 thermostat located added. HVAC-1 remote sensor located added. Central controller added.
- ITEM 14. Sheet M33.04 – REPLACE in its entirety:
- a. Detail 2 replaced. Detail 3 added.
- ITEM 15. Sheet M42.00 – REPLACE in its entirety:
- a. DSB diagram updated with controls.
- ITEM 16. Sheet P22.00 – REPLACE in its entirety:
- a. Waste and vent routing updated. Floor sinks added to the kitchen.
- ITEM 17. Sheet P23.01 – Venting updated to match underground.
- ITEM 18. Sheet E00.03 – REPLACE in its entirety:
- a. Revised Panel K panel schedule.
- ITEM 19. Sheet E22.01 - REPLACE in its entirety:
- a. “OPERATORS TBD” removed from note on Doors 114 and 129B.
- ITEM 20. Sheet E32.01 – REPLACE in its entirety:
- a. Revised placement of existing Panel ‘LCA’ in Pet Care room to reflect existing conditions.
- ITEM 21. Sheet E42.01 – REPLACE in its entirety:
- a. Added duplex GFCI receptacles in wall above Item 31 worktable. Receptacles shall be mounted at +48” above finished floor.

1.5 SUBSTITUTION REQUESTS

- ITEM 1. SECTION 07 54 00 – THERMOPLASTIC MEMBRANE ROOFING
- a. Paragraph 2.3.A.1:
 - i. Mule-Hide 80 mil PVC KEE HP membrane roofing system, including all components and accessories – APPROVED (color to be selected by Architect)
 - ii. Carlisle 80 mil PVC – REJECTED: properties and characteristics not fully-comparable to basis of design spec.
 - b. Paragraph 2.3.A.2: Soprema Sentinel P200 80 mil PVC – APPROVED (color to be selected by Architect)
- ITEM 2. SECTION 08 71 00 – DOOR HARDWARE
- a. Paragraph 1.32, HW SET #s 16 & 19: HORTON Series 7000 Operators – APPROVED

ITEM 3. SECTION 22 11 00 – FACILITY WATER DISTRIBUTION

- a. Paragraph 2.10.B:
 - i. MIFAB#WHB – REJECTED, Not an Approved Manufacturer
 - ii. MIFAB#CL – REJECTED, Not an Approved Manufacturer

ITEM 4. SECTION 22 13 00 – FACILITY SANITARY SEWERAGE

- a. Paragraph 2.6.B: MIFAB F1100-C-1 – REJECTED; Not an Approved Manufacturer
- b. Paragraph 2.7.B: MIFAB T1500-PB-13-T100-PGE-4-HP – REJECTED; Not an Approved Manufacturer
- c. Paragraph 2.8.B: MIFAB FS1720 – REJECTED; Not an Approved Manufacturer
- d. Paragraph 2.9.B: MIFAB C1100-XR – REJECTED; Not an Approved Manufacturer
- e. Paragraph 2.9.C: MIFAB C1220 – REJECTED; Not an Approved Manufacturer
- f. Paragraph 2.9.D: MIFAB C1450 – REJECTED; Not an Approved Manufacturer
- g. Paragraph 2.9.E:
 - i. MIFAB C1100-R – REJECTED, Not an Approved Manufacturer
 - ii. MIFAB C1100-RC – REJECTED, Not an Approved Manufacturer
- h. Paragraph 2.9.F: MIFAB C1450-RD – REJECTED; Not an Approved Manufacturer
- i. Paragraph 2.9.G: MIFAB C1460 – REJECTED; Not an Approved Manufacturer
- j. Paragraph 2.12.B: MIFAB MT-500 – REJECTED; Not an Approved Manufacturer
- k. Paragraph 2.13.B: MI-702 – REJECTED; Not an Approved Manufacturer
- l. Paragraph 2.14.B: MIFAB MI-CAG – REJECTED; Not an Approved Manufacturer
- m. Paragraph 2.16.B: MIFAB BIG1150 – REJECTED; Not an Approved Manufacturer

ITEM 5. SECTION 22 14 00 – FACILITY STORM DRAINAGE

- a. Paragraph 2.4.B:
 - i. MIFAB R1200 – REJECTED, Not an Approved Manufacturer
 - ii. MIFAB 1200-R – REJECTED, Not an Approved Manufacturer
- b. Paragraph 2.5.B: MIFAB R1940 – REJECTED; Not an Approved Manufacturer
- c. Paragraph 2.6.B: MIFAB C1220 – REJECTED; Not an Approved Manufacturer
- d. Paragraph 2.6.C: MIFAB C1450 – REJECTED; Not an Approved Manufacturer
- e. Paragraph 2.6.D:

- i. MIFAB C1100-R – REJECTED, Not an Approved Manufacturer
 - ii. MIFAB C1100-RC – REJECTED, Not an Approved Manufacturer
 - f. Paragraph 2.6.E: MIFAB C1450-RD – REJECTED; Not an Approved Manufacturer
 - g. Paragraph 2.6.F: MIFAB C1460 – REJECTED; Not an Approved Manufacturer
- ITEM 6. SECTION 22 40 00 – PLUMBING FIXTURES
 - a. Paragraph 2.17.B: MIFAB HY-9000 – REJECTED; Not an Approved Manufacturer
 - b. Paragraph 2.17.C: MIFAB HY-2000 – REJECTED; Not an Approved Manufacturer
 - c. Paragraph 2.24.B: MIFAB MC-10/12/12D – REJECTED; Not an Approved Manufacturer
 - d. Paragraph 2.24.C: MIFAB MC-41/41D – REJECTED; Not an Approved Manufacturer
- ITEM 7. SECTION 23 81 43 – AIR-COOLED, VARIABLE REFRIGERANT FLOW, MULTI-UNIT HEAT PUMP
 - a. Paragraph 1.1 through 3.8: Samsung DVM S Eco Series Heat Pump Condensing Unit – REJECTED; Not an Approved Manufacturer

1.6 QUESTIONS

- Q1. Will retained wood flooring be refinished?
 - A1. No – retained wood flooring will not be refinished.
- Q2. Exhaust Hood – Do you know if there will be any additional specs coming for 11400 Foodservice Equipment? Has a Food Service Consultant been hired to do the design - which firm is it?
 - A1. Yes – see revised Section 11 40 00 – Foodservice Equipment attachment.
 - A2. Yes – Clevenger Associates.
- Q3. Section 230800 calls for CA to be employed by contractor while Section 019113 General Commissioning CA is owner employed. Who employs the commissioning agent?
 - A1. Per Section 23 08 00, Paragraph 1.2.B, the mechanical contractor shall retain a commissioning agent.
- Q4. Is the "Subcontractor Responsibility Checklist" to be filled out by us or by our subcontractors for the project?
 - A1. The General Contractor shall fill out the Subcontractor Responsibility Checklist.
- Q5. Is hand nailing the new shingle sections on the mansard really required?
 - A1. Yes. Given the visible condition of the existing roof, please install roofing as specified.

- Q6. Are the products listed in the underlayment Roofers' Select and Grace Ultra the only approved products?
- A1. While Roofers' Select and Grace Ultra are listed products in Section 07 31 13 Paragraphs 2.3.B.1 and 2.4.B.1 respectively, they are not the only approved products. See revisions to the specification sections in the project manual.
- Q7. Can we use other products covered by the warranty?
- A1. Yes – other products covered by the warranty may be submitted as substitution requests per the instructions in Sections 000 11 13, 000 21 13, and 01 25 00.
- Q8. Was there a core sample taken of each roof deck? Do we know what the existing system is currently?
- A1. No core samples were taken of each existing roof deck. Based on limited existing drawings, it is our understanding that the existing roof assembly is comprised of: Class A or B 3-ply hot mop, over 3/4" CDX sheathing, over wood roof joists at 32" on-center, over R-38 batt insulation, over 5/8" Type 'X' GWB.
- Q9. Is it in the roofer's scope to raise the penetrations or the mechanical contractors?
- A1. This pertains to means and methods and therefore shall be up to the General Contractor to coordinate.
- Q10. Are all gutters and downspouts in the areas of work being replaced?
- A1. Yes - all gutters and downspouts for the entire building shall be replaced. See Sheets C5.00, A20.21, A25.01, and A31.01 indicating new roof drains and roof drain systems.
- Q11. Are we preserving the existing drain field for future use?
- A1. No. See Sheet C5.00 indicating "DRAINFIELD (ABANDONED)".
- Q12. Is there any expectation for exterior electrical for the future kitchen needs?
- A1. No.
- Q13. After the site walkthrough there appears to be extensive rain drain storm water repair. Should this be included?
- A1. Yes. See Sheets C5.00, A20.21, A25.01, and A31.01 indicating new roof drains and roof drain systems.

Q14. On 7/S4.23, the kitchen roof calls for 24” open web trusses at 24” o.c.. We need the following information to help us determine which truss series is required. Could we get for the roof: 1) Design Dead Load, 2) Snow Load, 3) Wind Uplift in psf, and whether this is net or gross and ASD or ULT.

A1. The ceiling assembly above the kitchen per Detail 7/S4.23 is not a roof, and therefore does not have a snow load nor wind uplift. The design loads are as follows:

i. Dead Loads:

1. Design Dead Load: Truss self weight + 15psf. MAU-1, see plan 7/S4.23. Coordinate location with mechanical.

ii. Live Loads (also see S1.00):

1. 40psf Top Chord Live Load (TCLL).
2. 20psf Bot Chord Live load (BCLL), not combined with 40psf TCLL (i.e., bottom chord bending).

iii. Seismic Loads:

1. MAU-1, see plan 7/S4.23. Coordinate location with mechanical.

iv. Wind Loads: None.

v. Snow Loads: None.

Q15. There is no temperature controls vendor listed in 230900 or elsewhere in the specifications. Are there particular vendors that should be bidding on this scope?

A1. Central controls added for Heat Pumps, ERVs, & RTU. No particular vendors are required for this scope of work.

Q16. What specific items does the Owner wants salvaged?

A1. See demo keynotes and demo floor plan on Sheet A20.01 for items the Owner wants to salvage.

Q17. Section 02 41 19 SELECTIVE DEMOLITION, Paragraph 3.1.C states the Contractor is to engage a Professional Engineer to determine if removing indicated elements may result in a structural deficiency or unsafe condition during scope of work. Typically, the Owner hires the Engineer to perform this survey during the design phase. Please confirm that the bidders should hire a Professional Engineer to perform this survey.

A1. Refer to structural drawings for support of items shown to be demolished. If additional selective demolition beyond what is indicated in the bid documents is required, it is the Contractor’s sole responsibility to ensure structural stability during construction. If the Contractor requires engineering during demotion, Contractor shall engage a professional engineer.

- Q18. Section 32 33 00 SITE FURNISHINGS – Site furnishings are indicated on Sheets L1.01; A11.01; A81.01 and S4.25. Site 7 Bicycle Covered Shelter is CFCI, however the note on detail 8 on S4.25 states Bike Shelters by others. It also states that the Contractor is to verify structural stability. Please confirm that the GC should add Engineering Costs to purchase a specified structure. In the specification SITE 7 has the capacity of 8 bikes, yet A11.01 calls out a bicycle capacity of 4. Please clarify.
- A1. Yes – Bidders should include Engineering Costs for Site-7 bicycle covered shelter.
- A2. Removed "4" from bike rack note on Sheet C3.00 and from Site-7 bicycle covered shelter note on Sheet A11.01. The bike rack is existing equipment with an 8-bike capacity.
- Q19. Site 5 Benches per the Site Furnishing specification these benches are to be CFCI, yet the note on L1.01 states the Benches by Owner. Please clarify.
- A1. Site-5 benches shall be contractor furnished and installed. Removed "BY OWNER" from bench note on Sheet L1.01.
- Q20. 33 11 16 SITE WATER DISTRIBUTION; Paragraph 1.6A references Silverdale Water District, per the drawing C5.20 the apparent water purveyor is West Sound Utility District. Should the Silverdale Water District reference be replaced with West Sound Utility District?
- A1. Yes. See revised Spec Sections 33 11 16 and 33 31 00.
- Q21. Sheet A20.01 Demo Plan Note #24 – Is there an anticipated quantity of studs to be replaced in order to quantify how many studs will need to be removed and re-installed OR should this be an additional Unit Price provided by Bidders?
- A1. There is no anticipated quantity to be replaced. Existing stud spacing is unknown. New walls shall comply with the specified assemblies stud spacing. Spec Section 01 22 00 removed.
- Q22. Please confirm the following on E22.01: W/P outlet on the north wall shaded in the middle. Please confirm this outlet type.
- A1. This is a Weatherproof GFCI Receptacle.
- Q23. Please confirm the following on E22.01: Power for the door opener in the Lounge to the Hall and Family sleeping room. Please confirm the type of door opener. Plans show "TBD".
- A1. The Electrical Contractor shall provide power for door openers. Please refer to the Door Schedule on Sheet A60.01 for door hardware pertaining to these doors, and to the corresponding door hardware sets indicated in Specification Section 08 71 00.
- A2. "OPERATORS TBD" removed from note on Sheet E22.01.
- Q24. Please confirm the following on E22.01: LCA on the Pet Care section. The location is switched on the plan pages E22.01 and E32.01. Please confirm the location and confirm that this will not be in any pet wash area.
- A1. The LCA panel is existing and located per plans in the Pet Care area. Per Details 12/A34.01 and 16/A73.01 – the existing panel shall be shielded from water from the pet wash area.
- Q25. Who is responsible for trenching the Electrical and for dirt work in general?
- A1. This shall be coordinated between the General and Electrical Contractor.

Q26. Who is responsible for disposal of any Electrical component demolished or removed from the building?

A1. This shall be coordinated between the General and Electrical Contractor.

Q27. Is there a required/approved list of 3rd party subcontractors to use for specialty services?

A1. No there is not.

Q28. Will there be any specifics provided for any night lighting, or are the LED receptacle covers the only night lighting?

A1. The LED receptacle covers shall be the only night light provided.

Q29. I see that this project has federal funding but could not find any requirement for domestic materials. Could you please clarify if this project is subject to any Buy America/Buy American requirements, and if so, could you please provide the specific domestic requirement?

A1. Yes, this project is federally funded and therefore will need to satisfy any Buy America/Buy American requirements per the US Department of Commerce.

1.7 ATTACHMENTS

A. Specification Sections:

1. 000 00 10
2. 000 21 13-2
3. 000 21 13-7
4. 000 21 13-13
5. 01 29 00-4
6. 01 41 00-1
7. 01 74 19-2
8. 01 78 36-2
9. 01 91 13-1
10. 02 41 19-3
11. 07 31 13-2
12. 08 33 13-1
13. 11 40 00 (Full Spec Section)
14. 23 34 00 (Full Spec Section)
15. 23 38 00 (Full Spec Section)
16. 23 74 23 (Full Spec Section)

17. 27 00 00-1
 18. 33 11 16 (Full Spec Section)
 19. 33 31 00 (Full Spec Section)
- B. Drawing Sheets:
1. C3.00
 2. C5.00
 3. L1.01
 4. A00.01
 5. A11.01
 6. A21.01
 7. A25.01
 8. A26.02
 9. A34.01
 10. A60.01
 11. A72.01
 12. M00.03
 13. M00.04
 14. M22.01
 15. M33.04
 16. M42.00
 17. P22.00
 18. P23.01
 19. E00.03
 20. E22.01
 21. E32.01
 22. E42.01
- C. Pre-Bid Meeting Attendee Sign-in Sheet
- D. Pre-Bid Meeting Attendee Business Cards

END OF ADDENDUM NO. 2

SECTION 000 01 10 – TABLE OF CONTENTS

DIVISION 00 – PROCUREMENT AND CONTRACTING REQUIREMENTS

000 01 01	Project Title Page
000 01 03	Project Directory
000 01 10	Table of Contents
000 11 13	Invitation to Bidders
000 21 13	Instruction to Bidders
000 31 00	Available Project Information
000 41 13	Bid Form
000 41 13-A1	Bid Form Part 1 Bid Price Form
000 41 13-A2	Bid Form Part 1 Contractor's Bid Bond
000 41 13-A3	Bid Form Part 1 Insurance Binder
000 41 13-A4	Bid Form Part 1 Bidder Responsibility Checklist
000 41 13-A5	Bid Form Part 1 Non-Collusion Affidavit
000 41 13-A6	Bid Form Part 2 Subcontractor Work List
000 41 13-A7	Bid Form Part 3 Bid Form Part 3 Subcontractor Work List Steel & Rebar
000 41 13-A8	Bid Form Part 3 Subcontractor Responsibility Checklist
000 41 13-A9	Bid Form Part 3 Project References
000 52 13	Agreement Form
000 52 13-A1	Agreement Form A101-2017 Draft
000 52 13-A2	A101 Exhibit A-2017 Draft
000 61 13	Performance and Payment Bond
000 62 20	Statement of Intent to Pay Prevailing Wages
000 62 30	Affidavit of Wages Paid
000 72 00	General Conditions of the Contract
000 72 00-A	General Conditions A201-2017 Draft
000 73 00	Special Conditions of the Contract
000 73 00-A1	Special Conditions of the Contract Document
000 73 00-A2	HUD-50071 Certification of Payment to Influence Federal Transactions
000 73 00-A3	Certification Regarding Debarment and Suspension
000 73 19	Health and Safety Requirements
000 73 20	Supplemental Conditions Asbestos Abatement
000 73 43	Wage Rate Requirements
000 73 43-A1	Journey Level Prevailing Wage
000 73 43-A2	Apprentice Level Prevailing Wage
000 73 43-A3	Benefit Code Key
000 73 43-A4	HUD-4010 Federal Labor Standards Provisions
000 73 43-A5	Federal Wage Decision Number WA20230012
z00 31 00-A1	Water Sewer Availability
z00 31 00-A2	Fire Flow Report
z00 31 00-A3	Traffic Impact Analysis
z00 31 00-A4	Non-Wetland Determination
z00 31 00-A5	Hazardous Material Report

DIVISION 01 - GENERAL REQUIREMENTS

01 10 00	Summary
01 22 00	Unit Prices
01 25 00	Substitution Procedures
01 25 00.01	Substitution Request Form
01 26 00	Contract Modification Procedures
01 29 00	Payment Procedures
01 29 73	Schedule of Values
01 31 00	Project Management and Coordination
01 32 00	Construction Progress Documentation
01 33 00	Submittal Procedures
01 33 13	Certificate of Compliance
01 33 15	Certificate of No Hazardous Materials
01 33 23	Shop Drawings, Product Data and Samples
01 40 00	Quality Requirements
01 41 00	Regulatory Requirements
01 42 00	References
01 45 29	Testing Laboratory Services
01 50 00	Construction Facilities and Temporary Controls
01 55 00	Construction Facilities and Temporary Controls
01 60 00	Product Requirements
01 61 10	Materials and Equipment
01 63 10	Approval for Substitution and Product Options
01 65 10	Delivery, Storage, and Handling
01 73 00	Execution
01 73 29	Cutting and Patching
01 74 00	Construction Cleaning
01 74 19	Construction Waste Management and Disposal
01 77 00	Closeout Procedures
01 77 00-A	Closeout Checklist
01 78 23	Operations and Maintenance Data
01 78 36	Warranties and Bonds
01 78 36-A1	Warranty Contact List
01 78 36-A2	Subcontractor's Warranty Contact List
01 78 39	Project Record Documents
01 79 00	Demonstration and Training
01 91 13	General Commissioning

DIVISION 02 – EXISTING CONDITIONS

02 41 19	Selective Demolition
----------	----------------------

DIVISION 03 - CONCRETE

03 30 00 Cast-In-Place Concrete
03 30 03 Underslab Vapor Retarder

DIVISION 04 - MASONRY

04 20 00 Unit Masonry

DIVISION 05 - METALS

05 12 00 Structural Steel Framing
05 50 00 Metal Fabrications

DIVISION 06 - WOOD, PLASTICS, AND COMPOSITES

06 10 00 Rough Carpentry
06 41 00 Architectural Wood Casework

DIVISION 07 - THERMAL AND MOISTURE PROTECTION

07 25 00 Weather Barriers
07 31 13 Asphalt Shingles
07 46 46 Fiber Cement Siding
07 54 00 Thermoplastic Membrane Roofing
07 62 00 Sheet Metal Flashing and Trim
07 84 00 Firestopping
07 90 05 Joint Sealers

DIVISION 08 - OPENINGS

08 11 13 Hollow Metal Doors and Frames
08 15 73 Interior Sliding Doors
08 33 23 Coiling Counter Doors
08 38 00 Traffic Doors
08 710 0 Door Hardware
08 80 00 Glazing

DIVISION 09 - FINISHES

09 21 16 Gypsum Board Assemblies
09 51 00 Acoustical Ceilings
09 65 00 Resilient Flooring
09 68 13 Tile Carpeting
09 90 00 Painting and Coating

DIVISION 10 - SPECIALTIES

10 14 00	Signage
10 21 13	Toilet Compartments
10 22 20	Modular Kennel Partitions
10 26 00	Wall and Corner Protection
10 28 00	Toilet, Bath, and Laundry Accessories
10 44 00	Fire Protection Specialties
10 56 23	Wire Storage Shelving

DIVISION 11 - EQUIPMENT

11 30 00	Residential Equipment
11 40 00	Foodservice Equipment

DIVISION 12 - FURNISHINGS

12 36 00	Countertops
----------	-------------

DIVISION 21 - FIRE SUPPRESSION

21 00 00	Fire Suppression General Conditions
21 05 00	Common Work Results for Fire Suppression
21 13 13	Wet-Pipe Sprinkler Systems
21 13 16	Dry-pipe Sprinkler Systems

DIVISION 22 - PLUMBING

22 00 00	Plumbing General Conditions
22 05 00	Common Work Results for Plumbing
22 07 00	Plumbing Insulation
22 08 00	Project Commissioning (by Commissioning Agent)
22 11 00	Facility Water Distribution
22 13 00	Facility Sanitary Sewerage
22 14 00	Facility Storm Drainage
22 23 00	Natural-Gas Systems
22 30 00	Plumbing Equipment
22 40 00	Plumbing Fixtures

DIVISION 23 - HEATING, VENTILATING, AND AIR CONDITIONING

23 00 00	HVAC General Conditions
23 05 00	Common Work Results for HVAC
23 05 93	Testing, Adjusting and Balancing
23 07 00	HVAC Insulation
23 08 00	Project Commissioning
23 09 00	Instrumentation and Control for HVAC
23 23 00	Refrigerant Piping
23 31 00	HVAC Ducts and Casings
23 33 00	Air Duct Accessories
23 34 00	HVAC Fans
23 37 00	Air Outlets and Inlets
23 38 00	Hoods
23 40 00	HVAC Filters
23 72 00	Energy Recovery Units
23 74 00	Outdoor Air-Handling Units
23 74 23	Outdoor Makeup Air Handling Units
23 81 43	Air-Cooled, Variable Refrigerant Flow, Multi-Unit Heat Pump
23 83 23	Electric Terminal Heating Units

DIVISION 26 - ELECTRICAL

26 05 00	Electrical Materials and Methods
26 05 19	Building Wire and Cable
26 05 26	Grounding for Electrical Systems
26 05 29	Hangers and Supports for Electrical Systems
26 05 33	Raceway and Boxes
26 05 53	Identification for Electrical Systems
26 24 16	Panelboards
26 27 26	Wiring Devices and Trim Plates
26 28 13	Fuses
26 28 19	Enclosed Switches
26 29 13	Motor Control
26 32 13	Generator and Transfer Switch
26 51 00	Interior Luminaires
26 56 00	Exterior Luminaires

DIVISION 27 - COMMUNICATIONS

27 00 00	Telephone and Data System
----------	---------------------------

DIVISION 28 - ELECTRONIC SAFETY AND SECURITY

28 13 00	Entry Access/Security System
28 31 00	Fire Alarm Systems

DIVISION 31 - EARTHWORK

31 10 00	Site Clearing
31 22 13	Rough Grading
31 23 16	Excavation
31 23 16.01	Unanticipated Discovery Plan
31 23 17	Trenching
31 23 18	Rock Removal
31 23 23	Fill
31 25 00	Erosion and Sedimentation Controls

DIVISION 32 – EXTERIOR IMPROVEMENTS

32 00 00	Site Improvements
32 05 16	Aggregate Materials
32 11 23	Aggregate Base and Top Course
32 12 16	Asphalt Paving
32 17 23	Pavement Markings
32 18 16.23	Playground Protective Surfacing
32 31 13	Chain Link Fences and Gates
32 33 00	Site Furnishings
32 80 00	Irrigation Components
32 91 13.16	Mulching
32 91 19	Landscape Grading
32 91 19.13	Topsoil Placement and Grading
32 92 23	Sodding
32 93 00	Plants

DIVISION 33 - UTILITIES

33 11 16	Site Water Distribution
33 31 00	Sanitary Sewage Systems
33 41 00	Site Storm Sewerage Systems

- G. A **“Bid”** is a complete and properly signed proposal to do the Work or designated portion thereof, submitted in accordance with the Bidding Documents, for the sums therein stipulated and supported by any data called for by the Bidding Documents.
- H. A **“Bidder”** is a person or entity who submits a Bid for a prime contract with the Owner for the Work described in the Contract Documents.
- I. The **“Bidding Documents”** include the Advertisement or Invitation to Bid, Instructions to Bidders, the Bid form, any other sample Bidding and contract forms, the Bid Bond, and the Contract Documents, including any Addenda issued prior to receipt of Bids.
- J. The **“Contract Documents”** for the Work consist of the Agreement Between Owner and Contractor, the General Conditions of the Contract (as well as any Supplemental, Special or other Conditions included in the Project Manual), the Drawings, the Specifications, and all Addenda issued prior to, and all modifications issued after, execution of the Contract.
- K. The **“Owner”** is Kitsap County Department of Human Services.
- L. To be considered **“Responsible”** or meet **“Responsibility”** requirements, a Bidder must meet the following supplemental criteria applicable to this Project to the satisfaction of the Architect and the Owner:
- (1) The ability, capacity, and skill to perform the Contract;
 - (2) The character, integrity, reputation, judgment, experience, and efficiency of the Bidder;
 - (3) Whether the Bidder can perform the Contract within the time specified;
 - (4) The previous and existing compliance by the Bidder with laws relating to the Contract;
 - (5) The quality of performance of previous contracts, including demonstration of successful completion of similar projects of equal or greater size, scope and value in the last three (3) years;
 - (6) The designated Project Manager shall have a minimum of five (5) years of successful experience in project management and scheduling of projects of similar scope and complexity;
 - (7) The designated Superintendent shall have a minimum of five (5) years of successful supervision of projects of similar scope and complexity;
 - (8) Any other qualifications required by the Contract Documents or Bidding Documents; and
 - (9) Attend the mandatory Pre-Bid and Pre-Construction meetings.
 - (10) Such other information as may be secured having a bearing on the decision to award the contract.
- M. A **“Sub-bidder”** is a person or entity who submits a bid to a Bidder for materials, equipment or labor for a portion of the Work.
- ~~N. A **“Unit Price”** is an amount stated in the Bid as a price per unit of measurement for materials, equipment or services as described in the Bidding Documents or in the Contract Documents. The Owner reserves the right to reject at any time, without impairing the balance of the proposal, any or all such predetermined unit prices.~~

listed and their sum(s), the component amounts listed shall govern.

4. **Initial changes.** Any interlineation, alteration or erasure must be initialed by an authorized representative of the Bidder.

~~5. **Alternates and Unit Prices.** All requested Alternates and unit prices should be bid. The Owner reserves the right, but is not obligated, to reject any Bid on which all requested Alternates or unit prices are not bid. If no change in the Base Bid is required for an Alternate, enter "No Change." If there is no entry, it will be presumed that the Bidder has made no offer to accomplish this Alternate. If it is not otherwise clear from the Bid or nature of the Alternate, it will be presumed that the amount listed for an Alternate is an add rather than a deduct.~~

6. **No conditions.** The Bidder shall make no conditions or stipulations on the Bid form nor qualify its Bid in any other manner.

7. **Identity of Bidder.** The Bidder shall include in the specified location on the Bid form the legal name of the Bidder and, if requested, a description of the Bidder as a sole proprietor, a partnership, a joint venture, a corporation (including the state of incorporation), or another described form of legal entity. The Bid shall be signed by the person or persons legally authorized to bind the Bidder to a contract. A Bid submitted by an agent shall have a current power of attorney attached certifying the agent's authority to bind the Bidder, and provide other information requested.

8. **Bid amounts do not include sales tax.** The Bid shall include in the sum stated all taxes imposed by law, EXCEPT STATE AND LOCAL SALES TAX ON THE CONTRACT SUM.

9. **Bid breakdown.** The Bid form may contain, for the Owner's accounting purposes only, a breakdown of some or all of the components included in the Base Bid.

B. POTENTIAL LISTING OF SUBCONTRACTORS

1. **Procedure.** On certain projects of the Owner, the Bid form includes a requirement that certain Subcontractors be listed, and the list must be submitted to the Owner as described in the bidding documents. In these circumstances, the Bidder must name the Subcontractor with whom the Bidder, if awarded the Contract, will subcontract **directly** (i.e., not lower-tier Subcontractors) for performance of the work of:

- (a) HVAC (heating, ventilation and air conditioning),
- (b) plumbing as described in RCW 18.106,
- (c) electrical work as described in RCW 19.28,
- (d) structural steel installation,
- (e) rebar installation, and
- (f) any other categories of Work listed on the Subcontractor listing form(s).

TIMING: The listing of HVAC, plumbing, and electrical subcontractors shall occur within one hour of the published bid submittal time. The listing of structural steel installation and rebar

CONSIDERATION. In considering a Bidder's Responsibility, a Bidder shall be deemed to be unqualified to perform the Contract if, after review and verification of the representations included upon the Contractor's Qualification Statement submitted by the Bidder, conditions such as, but not limited to, the following appear:

- (a) The Bidder does not have sufficient prior experience (or an acceptable substitute thereof, as described below) with projects of a similar nature in technical, managerial, and financial requirements to that in the present Contract being bid. In addition to such established contractors, a newly established contractor may be considered qualified if it has shown on the Contractor's Qualification Statement that it is staffed with sufficient technical, managerial, and financial personnel with prior experience in the nature of construction for which the Bids are invited.
- (b) The Bidder does not have sufficient capability to undertake the obligations of the Contract. A determination will be made when the Owner's review of the probable cash flow needs of the Bidder for this Project (including payroll, cost of material and supplies, equipment rental costs, and any other direct or incidental costs of the Contract), concludes that the Bidder does not have sufficient financial resources to enable it to satisfy its financial obligations under the Contract.
- ~~(c) The Bidder has submitted unrealistic unit prices as determined by other Bidders' unit prices for this Project.~~
- (d) The Bidder does not have sufficient staff, equipment, or plant available to perform the Contract. The Owner's determination in this matter will be based upon that represented by Bidder in the Contractor's Qualification Statement.
- (e) The Bidder has a history of unsatisfactory performance of contracts of this or similar nature, regardless of whether such contracts existed between the Owner and the Bidder, or other parties.

- A determination of this nature will be made if the Owner, after review of the Bidder previous work experience, determines that the Bidder's unsatisfactory performance has resulted predominantly from the Bidder's failure rather than a failure to perform by another party. The Owner will give the Contractor an opportunity to explain such nonperformance's before any final determination is reached.
- A determination of failure to perform will be made if the Owner is satisfied after review of the Bidder's prior experience, that the Bidder has failed to satisfy its obligations under past contracts and the Owner cannot safely assume satisfactory performance of the Contract by the Bidder.
- In reaching its determination, the Owner may consider statements of other parties to the prior unperformed contracts, as well as the representations of the Bidder on its Contractor's Qualification Statement.

3. **Subcontractors.** The Responsibility of the Bidder may be judged in part by the Responsibility of its Subcontractors. Bidders must verify Responsibility criteria for each first-tier Subcontractor. A Subcontractor of any tier that hires other Subcontractors must verify Responsibility criteria for each of its next lower-tier Subcontractors. Verification shall include that each Subcontractor, at the time of subcontract execution, is Responsible and

- J. Waivers of Mechanic's Lien: With each Application for Payment, submit waivers of mechanic's lien from entities lawfully entitled to file a mechanic's lien arising out of the Contract and related to the Work covered by the payment.
1. Submit partial waivers on each item for amount requested in previous application, after deduction for retainage, on each item.
 2. When an application shows completion of an item, submit conditional final or full waivers.
 3. Owner reserves the right to designate which entities involved in the Work must submit waivers.
 4. Waiver Forms: Submit executed waivers of lien on forms acceptable to Owner.
- K. Waivers of Mechanic's Lien: With each Application for Payment, submit waivers of mechanic's liens from subcontractors, sub-subcontractors, and suppliers for construction period covered by the previous application.
1. Submit partial waivers on each item for amount requested in previous application, after deduction for retainage, on each item.
 2. When an application shows completion of an item, submit conditional final or full waivers.
 3. Owner reserves the right to designate which entities involved in the Work must submit waivers.
 4. Submit final Application for Payment with or preceded by conditional final waivers from every entity involved with performance of the Work covered by the application who is lawfully entitled to a lien.
 5. Waiver Forms: Submit executed waivers of lien on forms, acceptable to Owner.
- L. Initial Application for Payment: Administrative actions and submittals that must precede or coincide with submittal of first Application for Payment include the following:
1. List of subcontractors.
 2. Schedule of values.
 3. Contractor's construction schedule (preliminary if not final).
 4. Combined Contractor's construction schedule (preliminary if not final) incorporating Work of multiple contracts, with indication of acceptance of schedule by each Contractor.
 5. Products list (preliminary if not final).
 - ~~6. Schedule of unit prices.~~
 7. Submittal schedule (preliminary if not final).
 8. List of Contractor's staff assignments.
 9. List of Contractor's principal consultants.
 10. Copies of building permits.
 11. Copies of authorizations and licenses from authorities having jurisdiction for performance of the Work.
 12. Initial progress report.
 13. Report of preconstruction conference.
 14. Certificates of insurance and insurance policies.
 15. Performance and payment bonds.
 16. Data needed to acquire Owner's insurance.
- M. Application for Payment at Substantial Completion: After Architect issues the Certificate of Substantial Completion, submit an Application for Payment showing 100 percent completion for portion of the Work claimed as substantially complete.
1. Include documentation supporting claim that the Work is substantially complete and a statement showing an accounting of changes to the Contract Sum.
 2. This application shall reflect Certificate(s) of Substantial Completion issued previously for Owner occupancy of designated portions of the Work.

SECTION 01 41 00 – REGULATORY REQUIREMENTS

PART 1 GENERAL

1.1 REQUIREMENTS INCLUDED

- A. Description
- B. Applicable Codes and Ordinances
- ~~C. Standards by Reference~~

1.2 RELATED REQUIREMENTS SPECIFIED ELSEWHERE

- A. The General Conditions of the Contract and Supplemental General Conditions
- B. Refer to specific Sections in Division One.

1.3 DESCRIPTION

- A. This section states general regulation requirements and standards which apply to the construction of this Project.

1.4 APPLICABLE CODES AND ORDINANCES

- A. Comply will all governing laws, ordinances, statutes, rules, and regulations bearing on the conduct of the work as drawn and specified. This includes modifications, amendments, additions, and the like, current as of Bid date.
- B. Referenced codes establish minimum requirement levels. Where provisions of various codes or standards conflict, the more stringent provisions govern. Promptly submit to Architect written notice of observed contract document variations from legal requirements.

~~C. Compliance requirements include, but are not limited to, the following:~~

- ~~1. Seattle Building Code, 2015 Edition~~
- ~~2. Seattle Existing Building Code, 2015 Edition~~
- ~~3. Seattle and International Mechanical Code, 2015 Edition~~
- ~~4. Seattle and International Fire Code, 2015 Edition~~
- ~~5. Life Safety Code, Current Edition (reference code only)~~
- ~~6. Seattle Plumbing Code, IAPMO, 2015 Edition~~
- ~~7. State and City of Seattle Fire Marshall Requirements~~
- ~~8. Seattle and National Electrical Code, 2017 Edition.~~
- ~~9. Americans with Disabilities Act~~
- ~~10. International Building Code for Barrier-Free Accessibility, WAC51~~

1. Clean salvaged items.
 2. Pack or crate items after cleaning. Identify contents of containers with label indicating elements, date of removal, quantity, and location where removed.
 3. Store items in a secure area until installation.
 4. Protect items from damage during transport and storage.
 5. Install salvaged items to comply with installation requirements for new materials and equipment. Provide connections, supports, and miscellaneous materials necessary to make items functional for use indicated.
- B. Salvaged Items for Sale and Donation: Are not permitted on Project site. Owner will have first right of refusal on all salvaged waste material. Salvaged waste cannot be stored on site.
- C. Salvaged Items for Owner's Use: Salvage items for Owner's use and handle as follows:
1. Clean salvaged items.
 2. Pack or crate items after cleaning. Identify contents of containers with label indicating elements, date of removal, quantity, and location where removed.
 3. Store items in a secure area until delivery to Owner.
 4. Transport items to Owner's storage area designated by Owner.
 5. Protect items from damage during transport and storage.
- D. Doors and Hardware: Brace open end of door frames. Except for removing door closers, leave door hardware attached to doors.
- E. Equipment: Drain tanks, piping, and fixtures. Seal openings with caps or plugs. Protect equipment from exposure to weather.
- ~~F. Plumbing Fixtures: Separate by type and size.~~
- G. Lighting Fixtures: Separate lamps by type and protect from breakage.
- H. Electrical Devices: Separate switches, receptacles, switchgear, transformers, meters, panelboards, circuit breakers, and other devices by type.
- 3.3 RECYCLING CONSTRUCTION WASTE
- A. Packaging:
1. Cardboard and Boxes: Break down packaging into flat sheets. Bundle and store in a dry location.
 2. Pallets: As much as possible, require deliveries using pallets to remove pallets from Project site. For pallets that remain on-site, break down pallets into component wood pieces and comply with requirements for recycling wood.
 3. Crates: Break down crates into component wood pieces and comply with requirements for recycling wood.
- B. Wood Materials:
1. Clean Cut-Offs of Lumber: Grind or chip into small pieces.
 2. Clean Sawdust: Bag sawdust that does not contain painted or treated wood.
- 3.4 DISPOSAL OF WASTE
- A. General: Except for items or materials to be salvaged, recycled, or otherwise reused, remove waste materials from Project site and legally dispose of them in a landfill or incinerator acceptable to authorities having jurisdiction. No construction waste can be sold or given away on the project site.
1. Except as otherwise specified, do not allow waste materials that are to be disposed of accumulate on-site.
 2. Remove and transport debris in a manner that will prevent spillage on adjacent surfaces and areas.
- B. Burning: Do not burn waste materials.

5. Disclaimers and Limitations - Manufacturer's disclaimers and limitations on product warranties do not relieve the Contractor of the warranty on the work that incorporates the products nor does it relieve suppliers, manufacturers, and subcontractors required to countersign special warranties with the Contractor.

1.4 START OF WARRANTIES

- A. Warranties shall begin at the date of Substantial Completion of the Work, with the exception of warranties for the HVAC equipment which shall commence with the acceptance of the Commissioning Report by the Owner. Reference Section 00 72 00 – General Conditions of the Contract for Construction, Article 9, paragraphs 9.8.4 and 9.10.2.

1.5 SUBMITTAL REQUIREMENTS

- A. Assemble Warranties, Bonds, and Service and Maintenance Contracts, executed by each of the respective Manufacturer, Suppliers and Subcontractors.
- B. Contractor and each Subcontractor shall submit a completed Warranty Contact List as attached to this section or in a similar format.
- C. Format
 1. Bind each manual in a three-ring, heavy-duty, vinyl, hardboard cover binder.
 2. On cover, imprint title "Warranty Manual"; name of project, Owner, Architect; and date of substantial completion.
 3. On bound edge, imprint name of project and owner and date of substantial completion.
 4. Pages to be neat, clean sheets, 8-1/2 by 11-inch maximum size or accordion foldouts to same size.
 5. Items to be identified with tabbed dividers showing name and number of appropriate specification sections.
 6. Arrange dividers and items in order they occur in specifications.
- D. Information Required
 1. Table of contents identifying separate warranties by specification section number and name.
 2. Contractor's warranty of the work per contract documents.
 3. Warranties, certificates, and bonds for all portions of the work per specifications, Divisions 1 through 33.
 4. Certificate of occupancy obtained from appropriate building officials.
- E. Provide complete information for each item:
 1. Product or Work Item.
 2. Firm, with name of principal, address, and telephone number.

SECTION 01 91 13 - GENERAL COMMISSIONING

PART 1 - GENERAL

1.1 SUMMARY

- A. The Mechanical Contractor will employ an independent Commissioning Authority. The Commissioning Authority is an independent and knowledgeable third party, hired to verify that the systems work as intended. The Commissioning Authority will inform the Owner and the Architect of the results of commissioning and provide recommendations for final acceptance of commissioned systems.
- B. Commissioning is the process to verify to the Owner that mechanical and electrical systems, as well as other special systems, function together properly to meet the facility performance requirements and design intent as described in the Contract Documents. The Contractor shall be responsible for participation in the commissioning process as outlined below, and in references and attachments throughout the Contract Documents. The Contractor shall furnish labor and materials sufficient to meet all requirements of building commissioning under this contract.
- C. The Commissioning Authority, acting on the behalf of the Owner, will be cognizant of the fact that the Owner's Facilities Staff needs to be informed and given the opportunity to participate actively in the commissioning process to ensure a complete, thorough turnover of systems once the project is complete. To this end, the Commissioning Authority will ensure that Facilities Personnel are informed of commissioning activity and schedule, and of any coordination issues such as special testing procedures or opportunity for hands-on training during functional testing.
- D. The Commissioning Authority is not authorized to modify, add to, or revoke the requirements of the Contract Documents. A change in the work can only be made as provided in the General Conditions.
- E. Various sections in the Division(s) 21-25 – General Mechanical Provisions, Plumbing, Heating, Ventilating, and Air Conditioning (HVAC); and Division(s) 26-27 - Electrical specifications outline the specific commissioning responsibilities of each subcontractor for that division, and also obligate the Contractor to coordinate and manage the commissioning responsibilities of those subcontractors.

1.2 RELATED WORK

- A. Drawings and general provisions of Contract, including General and Supplementary Conditions and Division 1 Specification Sections, apply to the work of this section.
- B. General requirements for testing agencies as specified in the Division 1.
- C. Applicable Divisions 21-25 sections identifying the requirements for plumbing and HVAC systems relating to the installation of mechanical equipment and systems, particularly with respect to equipment and system testing, start-up and performance demonstration/observation. Coordinate with the work of Divisions 26-27.
- D. Applicable Divisions 26-27 sections specifying the requirements for materials and installation of electrical equipment and systems, particularly with respect to equipment and system testing, start-up and performance demonstration/observation. Coordinate with the work of Divisions 21-25.

1.3 TERMS

- A. Acceptable Performance: A component or system being able to meet specified design parameters under actual load, including satisfactory documented completion of all functional performance tests, control system trending, and resolution of outstanding issues.
- B. Commissioning Authority: An independent and knowledgeable third party hired to verify that the systems achieve acceptable performance.

starting flame-cutting operations. Maintain portable fire-suppression devices during flame-cutting operations.

- D. Maintain fire watch during and for at least two hours after flame-cutting operations.
- E. Dispose of demolished items and materials promptly.

3.5 CLEANING

- A. Clean adjacent structures and improvements of dust, dirt, and debris caused by selective demolition. Return adjacent areas to condition existing before selective demolition rations began.
- B. Remove demolition waste materials from Project site and dispose of them in an EPA-approved construction and demolition waste landfill acceptable to authorities having jurisdiction.
 - 1. Do not allow demolished materials to accumulate on-site.
 - 2. Remove and transport debris in a manner that will prevent spillage on adjacent surfaces and areas.
 - 3. Remove debris from elevated portions of building by chute, hoist, or other device that will convey debris to grade level in a controlled descent.
- C. Dispose of all waste material in accordance with project's Waste Management Plan.

3.6 PROTECTION

- A. Remove temporary barricades and protections where hazards no longer exist.

3.7 UTILITY SERVICES AND MECHANICAL/ELECTRICAL SYSTEMS

- A. Existing Services/Systems to be Removed, Relocated, or Abandoned: Locate, identify, disconnect, and seal or cap off utility services and mechanical/electrical systems serving areas to be selectively demolished.
 - 1. Arrange to shut off utilities with utility companies.
 - 2. If services/systems are required to be removed, relocated or abandoned, provide temporary services/systems that bypass area of selective demolition and that maintain continuity of services/systems to other parts of building.
 - 3. Disconnect, demolish, and remove the fire suppression systems, plumbing, and HVAC systems, equipment, and components indicated on Drawings to be removed.
 - a. Piping to Be Removed: Remove portion of piping indicated to be removed and cap or plug remaining piping with same or compatible piping material.
 - b. Equipment to be Removed: Remove portion of ducts indicated to be removed and plug remaining ducts with same or compatible ductwork material.

3.8 SCHEDULE

- A. Locations and extent in accordance with demolition drawings.

~~B. Salvaged Items:~~

~~1. _____~~

END OF SECTION

- D. Protection against staining, mechanical damage, and live loads shall be provided for adjacent surfaces as required during application of roofing

1.7 WARRANTY

- A. Installation Warranty: Contractor shall correct defective Work within a 2 year period after Date of Substantial Completion.
- B. Manufacturer Warranty: Provide Lifetime material year warranty for shingles.
- C. Provide the owner with a 30-year manufacturer's warranty.

PART 2 PRODUCTS

2.1 DESCRIPTION

- A. Complete roofing assemblies, including factory formed asphalt shingles and installation accessories, tested for conformance with performance criteria.

2.2 PERFORMANCE AND DESIGN CRITERIA

- A. Fire Resistance: Class A, when tested in accordance with ASTM D3462/D3462M.
- B. Wind Resistance: Class F, when tested in accordance with ASTM D3161/D3161M.
- C. Warranted Wind Speed: Not less than tested wind resistance.

2.3 MATERIALS

- A. Asphalt Shingles: Asphalt-coated glass felt, mineral granule surfaced, complying with ASTM D3462/D3462M.
 - 1. Basis of Design: Landmark by CertainTeed. Comparable and substituted products will be judged based on the following performance criteria, features, warranty, and qualifications.
 - 2. Features:
 - a. Algae Resistant.
 - b. Color: Match existing asphalt shingles.
- B. Underlayment: felt reinforced with fiber glass fibers saturated with asphalt, complying with ASTM D6757 and ASTM D4869/D2260
 - 1. Basis of Design: CertainTeed Roofers' Select. Comparable and substituted products may be submitted and will be judged based on the following performance criteria and features.
 - 2. Features:
 - a. Asphalt-saturated felt, water resistant, algae resistant, mold resistant.

2.4 ACCESSORIES

- A. All accessory materials required by the manufacturer for a warrantable installation of the installed products in a manner that meets the Performance and Design Criteria.
- B. Manufacturer's optional accessories required by the project:
 - 1. Self-Adhering Membrane: Grace Ultra or approved equal.
 - 2. Nails: Hot dipped galvanized nails (ring shank) for hand nailing of shingles. Staples and pneumatically driven nails not allowed. Nails shall fully penetrate through the underside of the plywood sheathing.
 - 3. Asphaltic-based plastic cement conforming to ASTM D4586/D3409.
 - 4. Fasteners: Hot dipped galvanized roofing nails for nailing of shingles. Staples are not allowed. Nails shall fully penetrate through the underside of the plywood sheathing.

2.5 METAL FLASHING AND TRIM

- A. General: Comply with requirements in Section 07 62 00 Sheet Metal Flashing and Trim
- B. Fabricate sheet metal flashing and trim to comply with recommendations in SMACNA's "architectural Sheet Metal Manual" that apply to design, dimensions, metal, and other characteristics of the item.

SECTION 08 33 13 - COILING COUNTER DOORS

PART 1 GENERAL

1.1 SECTION INCLUDES

- A. Coiling counter doors, manually operated.

1.2 RELATED REQUIREMENTS

- A. 05 50 00 - Metal Fabrications: For support framing and framed opening.
- B. 08 71 00 - Door Hardware.
- C. 11 00 00 - Foodservice Equipment: For custom fabricated stainless steel counter sill.

1.3 SUBMITTALS

- A. Qualification Data: For manufacturer.
- B. Product Data: Provide general construction, component connections and details.
- C. Shop Drawings: Indicate pertinent dimensioning, anchorage methods, hardware locations, and installation details.
- D. Manufacturer's Installation Instructions: Indicate special preparation of substrate, installation and attachment methods, and perimeter conditions requiring special attention. Indicate installation sequence and procedures, adjustment and alignment procedures
- E. Warranty: Submit manufacturer warranty and ensure forms have been completed in Owner's name and registered with manufacturer.
- F. Maintenance Data: For user operation and maintenance of system including:
 - 1. Methods for maintaining system's materials and finishes.
 - 2. Precautions about cleaning materials and methods that could be detrimental to components, finishes, and performance.
 - 3. Maintenance Data: Indicate lubrication requirements and frequency and periodic adjustments required.
 - 4. Recommendations on maintenance schedule.

1.4 QUALITY ASSURANCE

- A. Manufacturer Qualifications: Company specializing in the manufacture of work specified in this section with minimum 5 years of experience.

1.5 DELIVERY, STORAGE, AND HANDLING

- A. As required by the manufacturer for a warrantable installation of the installed products to meet the Performance and Design Criteria.

PART 2 PRODUCTS

2.1 MANUFACTURERS

- A. Overhead Door Corporation, or approved equal.

2.2 COILING COUNTER DOORS

- A. Basis of Design: Overhead Door Corporation, 651 Series.
- B. Material: 22 gauge stainless steel curtain with interlocking slats, extruded aluminum guides.
- C. Between jamb mounting.
- D. Finish: No. 4 stainless steel.
- E. Operation: manual push up.
- F. Locking: slide bolt locks suitable for use with padlock.

PART 3 EXECUTION

3.1 EXAMINATION

- A. Verify opening sizes, tolerances and conditions are acceptable.
- B. Examine conditions of substrates, supports, and other conditions under which this work is to be performed.

SECTION 11 40 00 - FOODSERVICE EQUIPMENT

PART 1 - GENERAL

1.1 RELATED DOCUMENTS

- A. General provisions of the contract, including Foodservice Equipment General Conditions, Supplementary Conditions and General Documents, other Division 1 Specification Documents and other Division 1 specification sections apply under this section.

1.2 SCOPE OF WORK

- A. Furnish all labor, materials and services necessary for the procurement and installation of foodservice equipment in strict accordance with the Contract Documents and local codes including that which is reasonably inferred. No extra charge will be allowed for that which the Kitchen equipment contractor should be familiar.
- B. Supervise and provide required instructions for work to be performed by other contractors in connect with requirements for all equipment under this section.
- C. Related Sections include:
 - 1. Division 1 Section "Project Management and Coordination" for submitting and distributing meeting and conference minutes.
 - 2. Division 1 Section "Submittal Procedures" for submitting schedules and reports.
 - 3. Division 1 Section "Quality Requirements" for submitting a schedule of tests and inspections.

1.3 RELATED WORK SPECIFIED ELSEWHERE

- A. Floor and setting beds, quarry tile and base, masonry pads, walls and finishes, ceilings and related building work: Divisions 03 through 09.
- B. Wall backing to support all wall mounted equipment: Division 6 and 9.
- C. All water, waste, indirect waste piping from sinks, services to the equipment including all shut-off valves, plumbing trim, traps, etc., and final connections to the equipment except as specified herein: Division 22 and 23.
- D. All floor sinks and floor drains: Division 22.
- E. Piping sleeves for refrigeration and drain lines through building floors: Division 22.
- F. All electric services and components including wiring to and final connections to all equipment except as specified herein: Division 26.
- G. Furnishing and installation of main power lines to refrigeration systems control panel and wiring for control/defrost heaters between panel and coils in accordance with factory supplied wiring diagrams and local codes: Division 26.
- H. Ground type receptacles for all wall mounted outlet to be used for plug-in equipment: Division 26.

1.4 OWNER/PURVEYOR FURNISHED EQUIPMENT

- A. Obtain and coordinate manufacturer and model number not less than 60 days before equipment is required.
- B. Obtain and coordinate utility requirements.

1.5 EXISTING EQUIPMENT – N/A

1.6 REGULATIONS

- A. All work and materials shall be in accordance with the latest rules and/or regulations of agencies/authorities having jurisdiction.
- B. All regulations, including building codes, and other codes applying to this jurisdiction should be followed. In addition all equipment shall comply with the following:
 - 1. Local Health Code.
 - 2. National Fire Protection Association, Kitchen Ventilators (NFPA-96).
 - 3. National Electric Manufacturer’s Association (N.E.M.A.).
 - 4. Underwriters Laboratories Inc., (U.L.), must bear label. National Electric Code, (N.E.C.).
 - 5. National Sanitation Foundation, (N.S.F.), including NSF-7, must bear label in jurisdictions requiring the same.
 - 6. American Society of Mechanical Engineers must carry the (A.S.M.E.) stamp.
 - 7. American Gas Association, (A.G.A.).
 - 8. Occupational Safety and Health Act (O.S.H.A.) Standards.
 - 9. Hazard Analysis Critical Control Path (H.A.C.C.P.) Standards.
 - 10. American Disability Act (A.D.A.) Standards.
 - 11. Federal Energy Independence and Security Act of 2007 (HR6).
- C. The Contract Documents shall govern wherever they require larger sizes or higher standards than are required by regulations.
- D. The regulations shall govern whenever the Contract Documents require something which will violate the regulations.
- E. When seismic regulations are applicable, all equipment shall be fabricated and installed in accordance with those regulations. All seismic requirements shall be shown on all submittals. Submit requested information to the agencies and authorities having jurisdiction.
- F. No extra charge will be paid for furnishing items required by the regulations, but not specified and/or shown on the drawings.
- G. Rulings and interpretations of the enforcing agencies shall be considered a part of the regulations.

1.7 EQUIPMENT SUBSTITUTIONS

- A. Refer to Division 01 – General Requirements.
- B. Bids are to include price for each item, with a separate subtotal price for buy-out equipment, fabricated equipment, delivery, installation, and performance bond. Bidders may submit, pre-approved substitutions, other brands, and models of equipment. Bids will not be considered if they do not include pricing for all base items, even if substitutions are included. Substitutions shall be quoted on a separate page attached to the primary bid.
- C. When proposing and providing substituted equipment, Kitchen Equipment Contractor shall and pass on to Owner all lawful rebates, refunds, “spiffs”, credits, and discounts afforded it by virtue of its contract with those manufactures providing substituted equipment.
- D. Substitutions for engineered systems such as Exhaust Hoods, Refrigeration Racks and Walk-in Cooler/Freezer Assembly’s may be submitted in accordance with paragraph “B” above. If an alternate manufacture is accepted by the Owner, time spent by consultant, for coordination efforts with design team engineers via meetings or conference calls etc. will be back-charged to KEC at Consultants Standard hourly rates.
- E. Unspecified substitutions must be equal in all respects to the base equipment specified including all standard features. Bids for such substitutions must state the manufacturer, model number and include illustrations, specifications, capacities and operational data with the bid.
- F. If substitutions require different utility/building conditions, electrical, plumbing, ventilation, etc., from those specified, a complete list of those changes for each item shall be included with the substitute bid. The cost of these changes may become the responsibility of the Kitchen Equipment Contractor.
- G. Substitutions shall be submitted for approval prior to bid date. Acceptance or rejection of the substitutions will be at the discretion of the Owner and/or Designer prior to the bid date.
- H. Substitute manufacturer/model numbers listed in itemized equipment specifications can be assumed by bidders to be acceptable substitutions and do not need to be identified in bid.

1.8 REVIEW OF CONTRACT DOCUMENTS

- A. Unless expressly stipulated, and in a timely manner, no additional allowances will be made for Contractors or Manufacturers for errors, omissions or ambiguities not reported at time of bidding.
- B. Carefully review and compare the Contract Documents and at once report to Owner and/or Designer any errors, ambiguities, inconsistencies or omissions. Unless expressly stipulated, and in a timely manner, Kitchen Equipment Contractor shall be liable to Owner or Designer for any damage resulting from such errors, inconsistencies or omissions in the Contract Documents. Work shall not be done without approved Drawings, Specifications and/or Modifications and without receiving prior written authorization from Owner or Designer.

1.9 WARRANTY

- A. All equipment, fixtures and materials furnished and installed shall be guaranteed against defect in workmanship and material. All repairs and replacements which may have become apparent and necessary by reasons of such defects, during the first year after final completion and acceptance of equipment installation, shall be made without cost and expense to the Owner. All

such repairs and replacements shall be made at a time and during hours satisfactory to the Owner.

- B. For all commercially manufactured equipment that has refrigeration systems and semi-hermetic compressors, furnish an additional four (4) year warranty on all compressors.
- C. Warranty period shall commence with the date of final acceptance of installation by Owner.
- D. Components of equipment subject to replacement prior to one(1) year's use and those items which may fail due to improper or inadequate periodic maintenance by the Owner/Operator are not intended to be included within the scope of warranty.
- E. Provide all labor, material, refrigerants, and incidental expenses to maintain the temperatures specified on all refrigeration systems. Systems to be kept in first class working condition for a period of one (1) year from date of acceptance by Owner, or the date systems are put into operation, whichever occurs first, without additional cost to the Owner.

1.10 SUBMITTALS

- A. Use of Consultant's Drawings
 - 1. Consultant drawings are not intended for construction purposes, but are information intended only for use by the Architect and Engineers as an aid in the design of the building and utility distribution systems and for bidding equipment purchase. Consultant drawings in electronic format will not be issued by the Architect or Owner to third parties, including equipment suppliers, without express written consent of the Consultant.
 - 2. Consultant base Equipment Plans and Equipment Elevation Sheets will be provided to contracted equipment supplier in electronic format on request without charge. Utility rough-in/connection schedules and plans will be provided in electronic format on payment by the KEC to Consultant of a nominal fee of \$250 per drawing sheet for third party formatting. Regardless of fees charged the transfer of drawings is not to be considered a sale and the Consultant makes no warranties, express or implied, of Merchantability or of fitness for a particular purpose.
 - 3. Regardless of drawing formats provided it will remain the responsibility of equipment supplier to develop submittals in accordance with the Foodservice Equipment Specific Conditions and assume all required responsibilities thereto. Time spent in checking KEC re-submittals, for KEC deficient initial submissions, will be back-charged to the KEC at consultants standard billing rates. Time spent in extraordinary coordination efforts by the Consultant necessitated by poor performance of the KEC will be back-charged to the KEC at consultants standard billing rates. The Consultant is not to be liable for errors or omissions by the KEC's use of electronic data provided by the Consultant or the development of data used in the submittal approval process.
- B. Product Data
 - 1. After award of contract and before proceeding with the purchase of manufactured equipment, submit a bound Electronic PDF file copy of specification sheets consisting of:
 - a. Hard Cover.
 - b. Title Sheet.

- c. Index all items with columns for: Item number, quantity, description and status (fabricated, manufactured, by Owner/Operator, by General Contractor, et.).
 - d. A typewritten lead sheet for each manufactured equipment item showing: Item number, quantity, description; manufacturer's name, address and telephone; model number; optional finishes, equipment, accessories and modifications; utilities required and special notes.
 - e. Manufacturer's specification sheets and/or drawings.
2. Submittals not in the above format will be returned for re-submittal.
- C. Drawing Submittals
1. For all drawing submittals provide a bound Electronic PDF file copy.
 2. Plan drawings shall be at a scale of $\frac{1}{4}'' - 1'-0''$ (1:50).
- D. Rough-In Drawings
1. Drawings shall be dimensioned, showing ventilation requirements, floor and wall sleeves, plumbing, gas, steam, and electrical connections, including those items supplied by the Owner. Provide concrete pad dimensions, depressions and special conditions as required for equipment.
 2. The following shall each be drawn on separate sheets and/or plans: Itemized Equipment Plan/Schedule; Plumbing; Electrical; Building Works and Ventilation; Refrigeration and Beverage Systems.
 3. Utilities shall be stubbed out of walls wherever possible.
 4. Verify mechanical, electrical, and ventilation rough-in and sleeve/conduit locations before floor slabs are poured.
 5. In the event rough-in has been accomplished before the award of the contract, check existing facility and furnish all equipment to suit building conditions and utilities. No extra charges shall be allowed for utility changes to fit equipment during installation and connection.
- E. Wall Backing Drawings
1. Prepare and submit wall backing drawings. The drawings shall show the location and size of all wall backing required. The drawings shall be submitted for checking and to the General Contractor in time for the wall backing to be installed prior to closing of the walls.
- F. Shop Drawings
1. Prepare and submit shop drawings for all special fabricated items of work included in this contract. The detail drawings shall be submitted at minimum of $\frac{3}{4}''$ (1:20) scale for elevations and $1-1/2''$ (1:10) scale for sections. Drawings shall show all dimensions, all details of construction, installation and relation to adjoining and related work. Drawings shall show all reinforcements, anchorage and other related work required for the complete installation of all fixtures.
- G. Record Drawings

1. At the conclusion of the project and prior to final payment, provide updated record Drawings incorporating all changes that occurred during construction in the form of CAD disks and one (1) hard copy set.
 - a. Submittal drawings shall include as applicable; mep rough-ins, custom fabrication, engineered systems including exhaust hood, refrigeration, etc.

H. Checking

1. Checking product data, rough-in drawings, wall backing drawings, shop drawings, and refrigeration drawings by Designer is for design concept only, and does not relieve the Kitchen Equipment Contractor of responsibility for compliance with Contract Documents, verification of utilities with equipment requirements for conformity and location, verification of all dimensions of equipment and building conditions or reasonable adjustments due to deviations.
2. Drawings shall be prepared on the Kitchen Equipment Contractor's sheets and by his employees. Drawings and any part thereof created by photograph, paste-up, or other methods using Designer's drawings and/or details will be returned for re-submittal.
3. Submittals and checking shall be accomplished before ordering equipment or starting fabrication.

I. Requests for Information (RFI's)

1. All RFI's to be submitted per General Conditions or otherwise by e-mail to info@clevengerassoc.com or if known, by e-mail directly to the project manager.

J. Mailing and Distribution

1. All drawings shall be delivered via E-mail, FTP site or General Contractor share site.
2. After checking, supply the specified number of distribution prints and as many as ten (10) corrected product data books as directed by the Architect, General Contractor or Owner.

1.11 PARTS AND SERVICE MANUALS

- A. Furnish two (2) bound sets of parts and service manuals.
1. The manuals shall include a source directory for parts and service for all items.
 2. The manuals shall be submitted in time to allow review and transmittal to the Owner/Operator prior to start-up and demonstration of the equipment. Manuals must be submitted before the Owner will issue final acceptance of the installation.
 - a. Provide a bound electronic pdf file copy on cd of the record drawings as part of this submittal.

1.12 VERIFICATION AND COORDINATION OF PROJECT/DATA

A. Range Lines

1. All front manifold range lines shall be assembled and aligned at the factory before shipment, including back guards, high shelves and salamanders.

B. Pans and Inserts

1. Verify sizes with Owner on the following items before ordering or fabrication:

- a. Steam Pans.
- b. Sheet Pans.
- c. Trays.
- d. Glass and Cup Racks.

C. Quietness of Operation

Quietness of operation of all food service and refrigeration equipment is a requirement. Remove or repair any equipment producing abnormal and objectionable noises.

D. Delivery and Entry

Verify all conditions at the building, particularly door openings and passageways for large equipment. Coordinate with the General Contractor access to insure delivery of equipment to the required areas. Coordination shall include, but not limited to, early delivery, hoisting, window removal and/or delay of wall construction. All special equipment, handling charges, window removal, etc. shall be paid for by the Kitchen Equipment Contractor.

E. Connection Terminals

All equipment will be complete with standard connections as they relate to their Country of Origin. It shall be the responsibility of the Kitchen Equipment Contractor to provide any and all required adaptors to assure the proper connection to the conditions at the job site.

F. Site Verification

Notify Designer, Owner and the General Contractor in writing if, in the Kitchen Equipment Contractor's opinion, the jobsite is not adequate to insure proper installation of the equipment. Notification shall be in writing with sufficient time to effect corrective measures to meet the installation schedule.

PART 2 - PRODUCTS

2.1 COMMERCIALLY MANUFACTURED EQUIPMENT

- A. All items of standard equipment shall be the latest model at time of delivery.
- B. Follow manufacturer's directions used to fulfill this contract which cover points not necessarily shown on the drawings or specifications.
- C. All doors shall be hinged as shown on plans.

2.2 PLUMBING WORK

- A. Provide suitable pipe slots, chases and/or do all drilling, punching and cutting of equipment required to provide access for Division 22 connections and/or runs. Such work performed at the job site shall be of the same quality as similar work in the shop.

- B. To insure proper clearance for cleaning, all horizontal piping lines shall be run at the highest possible elevation through equipment and not less than 6" (150 mm) above floor, wherever possible.
- C. Indirect waste piping shall be installed in accordance with the local codes. Piping shall run as described hereinafter, and shall discharge into floor sinks. Extend piping to a point of at least 2" (50 mm) above rim of floor sink and cut bottom on 45° angle. All indirect waste piping shall be installed and routed in a manner to insure proper drainage and shall conform with shelves, spaces, equipment or building conditions. Indirect waste piping to be secured to fixture.
 - 1. Indirect waste piping from ice bins, ice pans or similar items shall be insulated to prevent condensation.
- D. Water inlets shall be located above the positive water level to prevent siphoning of liquids into the water system. Wherever conditions shall require a submerged inlet. Provide a suitable type of check valve and vacuum breaker.
- E. Where exposed, piping and fittings shall be chrome plated.
- F. All faucets intended to dispense water for human consumption shall be manufactured from pure stainless steel that contains zero lead, no brass allowed in the waterways of the product. Finish shall be polished stainless steel

Type 1: Faucet: 8" c/c wall mount base with ½" NPT male threaded inlets, lever handles & 12" swing nozzle with B-PT stream regulator outlet, ceramic cartridges with check valves & 24" stainless steel flexible supply hoses.

T&S Model # B-0231-CR-KIT

Type 2: Faucet: 8" c/c wall mount with ¾" NPT female inlet elbows & big-flo 14" swing nozzle.

T&S Model # B-0290-14

Type 3: Faucet: Single hole deck mount mixing, 6" swing nozzle with B-PT stream regulator, lever handles, eterna cartridges with spring checks & 18" flexible stainless steel supply hoses.

T&S Model # B-0202

Type 4: Faucet: Pot & Kettle sink mixing with 14" swing nozzle, 4-arm kitchen handles & ¾" NPT inlets.

T&S Model # B-0293-14

Type 5: Faucet: Single hole deck mount, 5 3/4" swivel/rigid gooseneck with B-PT stream regulator outlet, eterna cartridges with spring checks & 18" flexible stainless steel supply hoses.

T&S Model # B-0300

Type 6: Faucet: Single pantry, ceramic cartridges with check valve, 6" swing nozzle with B-PT stream regulator outlet, lever handle, ½" NPSM male inlet & tailpiece.

T&S Model # B-0207-CR

Type 7: Pre-Rinse Unit: Easy install, 8" c/c wall mount base, elbows with ½" NPT male inlets, 18" riser, B-0970-FEZ vacuum breaker, 44" flexible hose, 0.65 GPM low flow spray valve, ceramic cartridges with check valves & 6" wall bracket.

T&S Model # B-2278-CR-C-EL

Type 8: Pot filler: Wall mount, single control, double joint swivel nozzle, on-off volume

- control outlet with insulated grip, 4-arm handle & ½” NPT female inlet.
T&S Model # B-0592
- Type 9: Dipperwell Faucet: With spout, stainless steel bowl & removable inner overflow cup.
T&S Model # B-2282-01
- Type 10: Water Station: With pedestal type glass filler, adjustable flow outlet, 18 gauge stainless steel drip pan with drop-in grid & 1-1/4” drain.
T&S Model # B-1230-12
- Type 11: Pre-Rinse Unit: Easy install, 8” c/c wall mount base, add-on faucet with ceramic cartridge and lever handle, 12” swing spout with B-PT stream regulator outlet, 18” riser, B-0970-FEZ vacuum breaker, 44” flex hose, 0.65 GPM low flow spray valve, ceramic cartridges with check valves & 6” wall bracket.
T&S Model # B-2278-A12CRCEL
- Type 12: Pre-Rinse Unit: Easy install, single deck mount base, B-0970-FEZ vacuum breaker, ceramic cartridges with check valves, 18” flexible supply hoses, 24” riser, 44” flex hose, spray valve with 2.2 GPM non-splash aerator, lever handles & 6” wall bracket.
T&S Model # B0113-CR-BVB-A
- Type 13: Big-Flo Pre-Rinse Unit 8” Wall Mount, Add-On Faucet 14” Swing Nozzle, 36” Hose, 12” Bracket
T&S Model # B-0279

G. DRAINS AND WASTES

1. Furnish all necessary drains and wastes with the equipment and as follows:

- Type 1: Drain: Rotary waste valve with twist handle, 3-1/2” sink opening, 2” NPT male outlet & 1-1/2” NPT male adapter.
T&S Model # B-3950
- Type 2: Drain: Rotary waste valve with twist handle, 3-1/2” sink opening, 2” NPT male outlet & 1-1/2” NPT male adapter & removable strainer basket.
T&S Model # B-3950-SB
- Type 3: Drain: Rotary waste valve with twist handle, 3-1/2” sink opening, 2” NPT male outlet & 1-1/2” NPT male adapter & overflow tube with head assembly.
T&S Model # B-3950-01
- Type 4: Drain: Rotary waste valve with twist handle, 3-1/2” sink opening, 2” NPT male outlet & 1-1/2” NPT male adapter & overflow tube with head assembly & removable strainer basket.
T&S Model # B-3950-01-SB

H. Quick Disconnect Valves

1. Gas Lines
- a. Flexible gas connectors shall be manufactured by Dormont Manufacturing Co., kits to include the following: Gas Connector, Type 304 stainless steel hose, stainless steel braid with 360 degree rotational end fitting and a flexible polymer coating with an anti-microbial agent. Safety Quik quick disconnect valve with thermal shutoff and one-hand

operation. SwivelMax (2) multi-plane swivel fitting. Coiled restraining cable and hardware to prevent strain on gas connector. Safety-Set wheel placement system provided with anchoring system including removable thumb screws. Moveable gas appliance connectors must be of sufficient length to attached properly to the device and include all necessary fittings and related appurtenances required for the proper operation of the assembly. Assembly to be CSA design certified to ANSI Z21.69/CSA 6.16 standards and be NSF certified, limited lifetime warranty.

2. Water Lines

- a. Flexible water hoses with quick disconnect for ice machines, coffee and tea brewers and any mobile equipment requiring water connections. Swirl™ Water Supply Line shall be manufactured by Dormont Manufacturing Co. and be a coiled retractable polyurethane hose that is NSF certified with a maximum allowable temp of 160 degrees and maximum allowable pressure 100 PSIG. Lead Free Brass Quick Disconnect fitting to be provided with 2-way shut off to stop water at supply side and prevent back flow from equipment when disconnected. Flexible water line must be of sufficient length to attach properly to the device and include all necessary fittings and related appurtenances required for the proper operation of the assembly.

3. Combi Oven Water Connectors

- a. Flexible Combi-Oven water connectors shall be manufactured by Dormont Manufacturing Co. and should include the following: Combi-Oven Water Connector, Type 304 stainless steel hose, 304 stainless steel braid with Lead Free Brass flared end fittings, Lead Free Stainless Steel 2-way quick disconnect to be provided with 2-way shut off to stop water at supply side and prevent back flow from equipment when disconnected, Lead Free brass garden hose adapter, coated in gray anti-microbial PVC, limited lifetime warranty.

I. Water Filters

1. All ice machines, combi-ovens, coffee and tea makers or urns, carbonated beverage dispensers and steam equipment shall have a water filter of proper type as manufactured by Everpure, or as required by the equipment manufacturer.

2.3 FILTER EXHAUST HOODS, AND/OR WATER WASH VENTILATORS, AND UTILITY DISTRIBUTION SYSTEMS

- A. Provide all labor, material and installation services; verify sizes and locations of duct connections; and provide all exposed duct work from hoods, ventilators, and dishwashers to building duct work, including trim, closure panels and watertight or grease tight connection.
- B. 18-gauge (1.3 mm) type 304 stainless-steel external welded construction, in accordance with the latest edition of N.F.P.A. No.96 and International Mechanical Code, including all applicable appendices. Exposed welds to be ground and polished. Exhaust hoods to be U.L. Listed as available for length specified.
- C. Light fixtures to be U.L. listed for cooking equipment exhaust hoods, NSF-approved, and with sealed safety lenses.
- D. Furnish welded stainless-steel formed duct collars at ceiling or wall duct connections. Verify size and location of duct connections required in this contract before fabrication.

- E. Factory pre piped liquid chemical or water fire suppressant system complying with applicable local and N.F.P.A. regulations. Wet chemical fire suppression systems to comply with UL 300 Standards. Each pull station is to be clearly identified with a permanent type label, as to which exhaust hood(s) it is for. Each exhaust hood is to have a matching permanent type label, identifying which pull station activates its fire system. All pull stations shall be recessed in wall where possible.
- F. Water wash control panel to be by the same manufacturer as the ventilator/hood, with time clock control for automatic operation. Provide stainless-steel trim strips for recessed control cabinet applications. Where applicable provide stainless-steel chase for surface mounted control panel, from top of panel to ceiling, full width, and depth of panel.
- G. Abbreviations:
 - 1. ASTM: American Society for Testing and Materials
 - 2. CE: European Union Safety Standards
 - 3. CSA: Canadian Standards Association
 - 4. DCV: Demand Control Ventilation
 - 5. ETL: Intertek
 - 6. FPM: Feet Per Minute
 - 7. GFCI: Ground Fault Circuit Interrupter
 - 8. IMC: International Mechanical Code
 - 9. LED: Light Emitting Diode
 - 10. MUA: Make-up Air
 - 11. NFPA-96: National Fire Protection Association
 - 12. NSF: National Sanitation Foundation
 - 13. UDS: Utility Distribution System
 - 14. UL: Underwriter Laboratories
 - 15. VAV: Variable Air Volume
 - 16. VFD: Variable Frequency Drive
 - 17. WG: Water Gauge (in inches)
- H. Water Wash Exhaust Hood w/Make-Up Air
 - 1. Furnish and install a complete commercial kitchen exhaust ventilator/canopy/hood designed for efficiency, durability, operational convenience, and productivity. The canopy shall bear the Underwriters Laboratories U.L. label or ETL label, UL-listed range hood without exhaust fire damper per standard 710 and be fabricated in compliance with current NFPA-96 and a sanitation mark from an approved agency. The exhaust airflow shall be

- within the ETL or UL-listed air volumes and be based upon ASTM Standards F1704-05 and F2474-05 at minimum and must meet or exceed Washington State Energy Code requirements. Exhaust canopy and make-up air plenum shall be sized in length, width, and height to achieve successful capture/containment, and exhaust-to-atmosphere according to ASTM 1704-09 in relation to cooking equipment served below canopy. Grease extraction shall be provided by a single or multiple stage assembly that is tested to ASTM 2519-2005 to at least 93% efficiency and allows no more than 9 microns of grease particulates in size to enter the exhaust plenum, riser and ductwork beyond. Controls shall be listed by UL 508A or ETL and any control enclosure shall be NEMA 1 rated and be listed for installation inside the exhaust hood utility cabinet.
2. Operational exhaust airflow engineering shall be based on the convective heat generated by the appliances/equipment underneath each canopy. Exhaust hood engineering shall include convective heat calculations based on the input power of the appliance/equipment served as defined by ASTM Standards F-1704-05 Capture & Containment and F-2474-05 Heat Gain to Space. Final air volume calculations shall comply with the hood listing. Engineering shall not include any extraneous mitigating, exposed, and materially added capture/containment helps such as end skirts or end panels. Engineering shall assume a minimum 80% air volume MUA (Make-Up-Air) from a tempered source via a low velocity air flow perforated plenum with its bottom set at the top of the canopy. Plenum shall require no lights within perforated panels. Overall exhaust design shall limit FPM flow of MUA -including air from general air handling units- to a maximum of 75 FPM at bottom front lip of exhaust hood. Exhaust volume and static pressure engineering shall take grease extraction method, current duct and fan planning into account and assume operation at sea level at 75 F. ambient temperature in foodservice zones serviced.
 3. Exhaust canopy and MUA plenum design and installation shall be in accordance with the manufacturer's recommendations and conform to NFPA-96 guidelines and all applicable local codes. Canopy design shall take NFPA-96 and IMC code-required clearance to combustible requirements into account and clearly state exceptions and tolerances for distances within engineering and final submittal documents. Clearance engineering shall address construction make-up near or adjacent to canopy. Construction details to be provided by Architect of Record in final design process. Continuous front and rear angled mounting brackets - welded to canopy - shall be provided to facilitate mounting to wall and hanging from overhead building structure as applicable. Provide canopy with all-welded duct collar(s), and all hangers, supports and miscellaneous accessories as required for installation. Canopy construction shall be compliant with NFPA-96 standards.
 4. The entire canopy shall be constructed of 18-gauge (or thicker) stainless-steel with a #4 finish. Each canopy shall have a grease extraction filter housing of the same material as the canopy liner. The grease extraction filter housing shall be equipped with a concealed drip gutter the full length of the canopy that discharges into a minimum .5-gallon grease container for easy removal and daily cleaning. Canopies manufactured in multiple sections shall be provided with bolts, clips and all necessary hardware for reconnecting by the canopy installer. Control and lighting wiring and drains are to be disconnected for shipment. Reconnection in field shall be by applicable trades. A built-in wiring chase shall be provided for any applicable electrical controls on the hood face or elsewhere and shall not penetrate the capture area or require an external chase way.
 5. Hood manufacturer to provide water wash system for automatic hood plenum cleaning and grease extractor cleaning. The hood shall include as-required full-length wash manifolds equipped with brass spray nozzles and stainless-steel threaded plumbing fitting extending from low end of gutter for final plumbing connection by trades. When the wash cycle is initiated, the exhaust fan shall modulate or shut-off according to applicable code and

- manufacturer's wash system. The wash sprays shall come on for the length of time programmed in the control panel. All controls and components for operation of the Water Wash system shall be housed in the Exhaust Hood Control Cabinet. It is assumed that grease extractors will also require additional as-needed heavy cleaning via removal and wash separate from canopy assembly.
6. The canopy shall be equipped with recessed LED light fixture(s) complete with bulbs with color temperature at maximum 3000K with the following certifications U.L., CSA, NSF and CE for use in grease exhaust hoods in quantity sufficient to provide 50-foot candles at the cooking/working surface when hood is mounted 80" A.F.F. LED Light fixture(s) shall be factory pre-wired to a single connection point. Lamp body shall be stainless steel frame with a high temperature silicone seal. Junction box to accept standard ½" NPT fitting. Fixture shall contain no mercury or lead. Includes Light Switch mounted on hood face in recessed and fully enclosed manner unless otherwise controlled by hood control cabinet within working zone. Provide wires and ground for controls and light in flexible conduit 6' beyond end of canopy. Canopies built in multiple sections shall be furnished with coiled flex conduit for interconnecting sections.
 7. The canopy shall include an "Auto-start" controller and temperature sensor designed and installed to automatically activate the exhaust fan whenever cooking operation occurs. The activation of the exhaust fan shall occur through, and interlock with, the cooking appliances by means of heat sensor, per IMC 507 standards and requirements.
 8. Exhaust canopy operational planning shall include shut-down requirements for a fire condition based on applicable national, state, and local fire codes.
 9. Exhaust hood shall be provided with an integral DCV (Demand Control Ventilation) system capacity.
 10. Provide hood pre-piped in factory for Fire Suppression System with concealed piping and drops in roof of canopy at required locations above equipment served below.
 11. Provide with stainless steel compartment at end of hood for housing Fire Suppression System complete with removable door where shown on drawings.
 12. If not installed against the finished ceiling, provide matching stainless-steel closure panels above hood to finished ceiling, to conceal duct(s) and hood fire suppression system piping; verify height. If finished ceiling is more than 24" above the top of the hood(s), or ceiling is open type ceiling then verify requirement for closure panels with Architect/Interior Designer. Provide maintenance access above canopy where enclosure panels are required.
 13. Access for maintenance and service shall be done without access panels through the roof of the ventilator or at the duct shaft enclosure at the exhaust duct collar.
 14. Grease extraction filters shall be easily removable for cleaning, from the floor area immediately in front of the equipment by utilizing an extractor removal tool as provided.
 15. A factory-certified representative from the exhaust hood manufacturer shall conduct an exhaust hood performance test for each exhaust hood in the Contractor's scope of work at the conclusion of the project when all hoods and related cooking equipment are in full operational mode. Contractor shall have manufacturer's factory authorized representative test and measure exhaust airflow rates, dampers, switches, demand control ventilation, and sequence of operation, with all appliances at operating temperatures. Contractor shall furnish a written report within ten (10) working days of substantial completion and

acceptance of the project by the Owner, indicating the design requirements for each hood and the actual operating parameters as tested and measured.

16. Project-specific shop drawings/submittals shall be prepared and submitted for review and approval by the prospective manufacturer. The hood manufacturer shall supply complete computer-generated submittal drawings. These drawings shall show all-welded exhaust duct collar height and flange dimensions. Duct sizes, CFM and static pressure requirements shall also be clearly defined on drawings. Static pressure requirements shall be precise and accurate; air velocity and volume information shall be accurate within 1-ft increments along the length of the canopy. Drawings shall include hood sections view(s), hood elevation view(s), and hood plan view(s) complete with specified equipment blocks/families within drawings with equipment item numbers clearly defined and coordinated. No generic block forms/facsimiles of equipment are allowed. Drawings shall include all applicable listings and approvals as well as any applicable wiring or plumbing information. These drawings must be available to the engineer, architect, and owner for their use in construction, operation, and maintenance.
 - I. Condensate Exhaust Hood – N/A
 - J. Water Wash/Exhaust Control Panel
 1. Provide master water wash control panel for canopy water wash system. Panel to be source of digital programming of wash cycles and be locus of incoming and canopy service hot water connections as well as overflow drain. Control panel to also indicate any current faults for water wash system that needs operator attention. Panel number to be applicable to maximum number of hoods allowed to be serviced by one panel.
 2. Field start-up to be performed by manufacturer-authorized service agency.
 3. The master water wash control panel shall be able to provide automatic operation of the exhaust and supply fans in addition to the run & wash cycles of the exhaust hoods in a pre-programmed manner.
 4. The panel shall be complete with a separate electrical and plumbing compartment. Panel shall be designed to allow for 40psi minimum to 80psi maximum water pressure at inlet with water temperature tolerance of 140 F. to 180 F. maximum.
 5. The panel shall be provided with Run/Wash selector switch, wash timer, wash time delay, and a microprocessor for system running and alarm conditions. A terminal strip shall be provided for field wiring.
 6. The panel shall be supplied with a backflow prevention device and downstream backflow prevention devices as directed by code, a detergent pump and low-level alarm. Panel shall be provided with one (1) case four (4) bottles of detergent as well as a single floor-mounted barrel for each panel for supplemental or main detergent supply as needed.
 7. The panel shall be constructed from 14-gauge stainless-steel with hinged lift off doors, have a front locking screw and be recess mounted with a 1.5" wide stainless-steel trim ring. Panel shall be planned to be recessed in wall wherever possible in plan.
 8. The entire panel shall be completely factory preassembled, prewired, and tested ready for final in-field mechanical and electrical connections. Controls shall be listed by UL 508A or ETL and any control enclosure shall be NEMA 1 rated and be listed for installation inside the exhaust hood utility cabinet.

9. Panel may be combined within or directly adjacent to or conjoined with the Demand Control Ventilation System Panel depending upon manufacturer's system proposed.
 10. Project-specific shop drawings/submittals shall be prepared and submitted for review and approval by the prospective manufacturer. Shop drawings shall include schematic plan for piping lines, valves, etc. and any control wiring with assignment of responsibility and construction sequence.
 11. Start-up and training shall be included in system installation scope.
- K. Demand Control Ventilation System and Panel
1. The DCV system shall be provided to allow ventilation upstream from the canopy to be ramped up and down based on received input. The DCV shall be designed to allow for the spectrum of high-capacity cooking down to idle capacity defined by exhaust volume sufficient-to capture convective heat from equipment below a commercial cooking exhaust hood canopy. If the minimum idle capacity defined by the exhaust hood manufacturer is greater than 50% of the design exhaust airflow, deviance approval is required from the design team and energy modeler.
 2. The DCV system shall be mechanically and electrically designed to interface with the planned upstream multiple hood/ single or multiple (up to four [4] fans per controller) fan system utilized to exhaust to the atmosphere. This interface shall utilize listed programmable resistance temperature detectors mounted inside the exhaust canopy to accurately read sensible heat from the cooking equipment and vary the speed of the exhaust and make-up air fans accordingly. The DCV system must be capable of controlling multiple exhaust fans (4 max.), and MUA fan (Make-Up Air) or AHU (Air Handling Unit) via one system using a sensor alert approach in a programmable fashion.
 3. The DCV system shall contain a digital interface panel with connections to Mechanical Division provided VFD (Variable Frequency Drive) system controlling the rotational speed of an AC electric motor driving a ventilator fan system designed to exhaust to the atmosphere as part of their exhaust fan package. The DCV interface/display shall provide controls for canopy lights, programmable schedule, override function, show equipment status, energy savings values, troubleshooting, and control options. Interface shall incorporate room ambient temperature sensor, fire suppression integration controls, VFD connection terminals and be capable of wireless/direct-connect data connections. Panel shall be constructed of 304 series stainless-steel with #4 finish complying with NSF/ANSI 2-2010. Cabling for controls shall be provided in flex conduit extending 6' beyond panel.
 4. Each foodservice zone's air systems are targeted be designed to maintain 0.02" WG (water gauge) relative to adjacent spaces. Manufacturer to coordinate engineering to reach this goal where possible.
 5. Master control panel shall utilize BACnet communication protocol for building automation and control network compatibility (extend and type of controls to be verified). All to be ASHRAE, ANSI and ISO standard protocol.
 6. Upon hood activation, the controller(s) shall turn on the DCV system to its minimum exhaust rate with signal to modulate the exhaust rate between the minimum and maximum set points.
 7. DCV shall be designed to allow for programmable temperature adjustments for each individual sensor. DCV shall send a 0-10V modulation signal to each assigned VFD.

8. Multiple programmable algorithms shall be provided per exhaust canopy.
9. Mechanical Division to provide VFDs (Variable Frequency Drive) as part of fan package. VFDs shall allow full adjustment of minimum and maximum frequency set-point for proper kitchen balance. Drives shall contain motor thermal overload protection. Acceleration and deceleration times shall be fully adjustable.
10. Override button shall be provided on each kitchen exhaust hood that ramps the exhaust to 100% of the design exhaust airflow. Override shall have adjustable timeout value integrated into system.
11. Shall be minimum UL 508A listed, and IMC 507.2.1.1 compliant. Only listed and compliant demand control ventilation systems shall be accepted. System shall comply with all local codes.
12. Manufacturer shall perform the complete startup and commissioning process of the DCV system once all installation of the equipment and wiring is certified complete. Startup shall include:
 - a. Set all hood sections to design air flow.
 - b. Adjust the VFD set points.
 - c. Verify complete DCV system functionality per Sequence of Operations and maximize system optimization and provide a written report of the functionality of the system.
13. Division 16 shall be responsible for control wiring between the supplied demand control system control panel and the hood mounted sensors. Division 16 will also be responsible for wiring between the demand control system control panel and the VFDs and then from the VFDs to the exhaust/supply fan motors. Manufacturer to provide inter-connectivity cables between the hoods and associated control panels. Manufacturer shall provide room a temperature sensor. Electrical Division or assigned shall run low voltage and standard voltage wiring cables and required control power.
14. DCV system operational planning shall include shut-down requirements for a fire condition based on applicable national, state, and local fire codes.
15. Full system component - as well as electrical, low voltage schematic wiring shop drawings - shall be provided for the DCV system showing scope of sequence, scope of material, product, and installation process.
16. Start-up and training shall be included in system installation scope.

2.4 ELECTRICAL WORK

- A. For all fabricated equipment, furnish, install (and intertwine from load center) all outlets, switches, controls, conduit, service fittings and load centers as shown as specified for the specific fixture. Load centers shall be complete with individual “visi-trip” circuit breakers for each device built into or forming an integral part of the unit. Furnish to Division 26 a wiring schematic including circuit breaker diagram for load center.
- B. Insure that all equipment furnished under this contract shall be so wired, wound or constructed as to conform with the characteristics of electrical and other services at the premises.

- C. Appliances shall be new, of manufacturer's current production and furnished complete with motors drive mechanism and other electrical equipment if and as applicable. Wiring and connection diagrams shall be furnished with electricity operated machines and for all fabricated equipment.
- D. All conduit wiring shall be run concealed wherever possible. Conduit shall be continuous from outlet to outlet and from outlet to load center circuit or pull boxes and shall center and be secured in such a manner that each system shall be electrically continuous throughout. All conduits shall be thoroughly and substantially supported by accepted industry practices.
- E. Supply on each motor driven appliance or electrical heating unit, a suitable control switch or starter of proper type wherever such equipment is not so built.
- F. All plug-in equipment shall have plugs and cords furnished and installed. Coordinate work with Division 26 so that the receptacles provided will match the specific plugs installed as part of the plug-in equipment. any changes on cords and plugs required in the field due to lack of coordination between Division 26 and Kitchen Equipment Contractor shall be the latter's responsibility.
- G. All surface mounted receptacles indicated for fabricated equipment are to have Component Hardware Model R58-1010 or equal aluminum box complete with satin finish stainless steel cover and receptacle as indicated below:
 - 1. 2-pole, 3-wire grounding 20 amp; 125 V. Hubbell # 5352 or equal (NEMA 5-20R).
 - 2. 2-pole, 3-wire grounding 20 amp; 250 V. Hubbell # 5461 or equal (NEMA 6-20R).
 - 3. 2-pole, 3-wire grounding 30 amp; 250 V. Hubbell # 9330 or equal (NEMA -30R).
- H. All built-in receptacles indicated for fabricated equipment are to be 2" x 4" x 1-1/2" (50 mm x 100 mm x 38 mm) deep "Handy Box" tack welded to fixture and fitted with receptacle indicated above and satin finish stainless steel cover. Splash mounted receptacles to be horizontal with all other vertical.
 - 1. 30 AMP, 250 V receptacles require a 2-1/8" (54 mm) deep "Handy Box". If splash width to 2-1/2" (62 mm).
- I. All electrically heated, fabricated equipment shall be internally wired to a thermostatic control and an "on/off" red light indicator, both to be mounted in a terminal box with a removable access panel and located outside the heating area. Wiring to be nickel-plated copper, properly insulated.
- J. Provide all incandescent/LED bulbs and fluorescent/LED tubes required for equipment under this section.

2.5 FABRICATED EQUIPMENT

A. Special Fabricated Equipment

All specially fabricated equipment must be by one manufacturer acceptable to Designer and the Owner.

B. Workmanship

All work must be done in an approved workmanlike manner to the complete satisfaction of Designer and Owner.

C. Stainless Steel

All stainless steel shall be the U.S. Standard gauge, 18-8, Type 304, finish as noted in Paragraph 2.5N. The exception for using Type 430 stainless steel shall be as noted in the itemized specifications.

D. Galvanized Steel

All galvanized steel shall be electro-galvanized.

E. Welding and Soldering

1. All seams and joints shall be shop welded or soldered as the nature of the material may require. Welds to be ground smooth and polished to match original finish.
2. Framework of galvanized steel shall be welded construction. Where galvanizing has been burned off, the weld shall be touched up with high-grade aluminum paint.

F. Sound Deadening

The underside of all metal to tables, counters, drainboards, sinks and dishtables shall have a hard drying NSF approved mastic, such as manufactured by component hardware, 1/16" (2 mm) minimum thickness. Exposed mastic will not be acceptable.

G. Metal Top Construction

1. All seams and joints shall be one-piece welded construction, reinforced on the underside with galvanized steel reinforcing welded in place so tops can support heavy weight without deflection. Cross braces to be not more than 30" (760 mm) on center.
2. Field joints in stainless steel tops; where required due to limitation of sheet sizes, equipment sizes or installation requirements shall be welded, ground smooth and polished to blend with adjacent surfaces.
3. If inverted hat sections are used in lieu of channels, close ends. All exposed sides, ends, etc. shall be stainless steel #4 finish.

H. Fasteners

1. Exposed bolt heads will not be permitted on fixtures.
2. Butt joints made by riveting straps under seams and then filled with solder will not be accepted.
3. Rivets of any kind, including pop-rivets, will not be accepted.
4. Exposed screw heads, when necessary, shall be one of the same materials as the pieces joined and counter sunk flush.

I. Rolled Edges

Rolls shall be as detailed with corners bullnosed, welded, ground and polished.

J. Corners

Dishtables, drainboards, splashbacks and turned up edges shall have 1/2" (15 mm) or larger radius bends in all horizontal and vertical corners, coved at intersections unless specified otherwise.

K. Enclosed Cabinet Base

Bases shall be made of 18-gauge stainless steel sheets reinforced by forming the metal. Sides and partitions shall terminate at front in a 2" (50 mm) wide fully enclosed mullion and welded at intersections. Shelves are to be removable where detailed. Exposed ends, partitions and shelves are stainless steel.

L. Legs and Cross Rails

1. Equipment legs and cross rails shall be 1-5/8" (40 mm) 16-gauge stainless steel tubing unless otherwise noted. All welds at cross rails shall be continuous and ground smooth. Tack welds are not acceptable. Tops of legs to be fitted with Component Hardware A20-0406 or A20-0206 leg sockets or approved equal. Gussets are to be welded to underside of sinks and bracing.
2. Bottom of legs to be fitted with Component Hardware A10-0852 adjustable stainless steel foot or approved equal. Foot plug to be welded, ground and polished. When flanged feet are specified, use Component Hardware O10-0854 adjustable stainless steel foot or approved equal.
3. Enclosed cabinet bases mounted on 6" (150 mm) high legs are to be equipped with Component Hardware 8048 Series adjustable stainless steel counter legs or approved equal, with mounting plate as required.

M. Metal Gauge

Unless otherwise noted in Itemized Specifications or Details, all gauges to be manufactured to the following minimum thickness:

<u>Stainless Steel USS Gauge</u>	<u>Decimal Thickness</u>	<u>Millimeter Thickness</u>
12	.1094	2.78
14	.0781	1.98
16	.0625	1.59
18	.0500	1.27
20	.0375	0.95

N. Materials

All fabricated items to be provided in gauge, metal type and finished per the following table:

<u>Description</u>	<u>Gauge</u>	<u>Metal</u>	<u>Finish No.</u>
--------------------	--------------	--------------	-------------------

<u>Dishtable, Table and Countertops</u>	14	S.S.	4
<u>Hat Sections/Channel:</u>			
Unexposed	14	Galvanized	---
Exposed	14	S.S.	4
<u>Counter Body:</u>			
Framework	14	Galvanized	---
Aprons, Partitions, Backs and Ends:			
(Exposed)	18	S.S.	4
(Unexposed)	18	Galvanized	---
Shelves	16	S.S.	4
Refrigerators			
Interiors	20	S.S.	2B
<u>Doors</u>			
Outside faces	18	S.S.	4
Inside faces	20	S.S.	2B
<u>Drawer Pans</u>			
General	20	S.S.	2B
Refrigerated	20	S.S.	2B
<u>Shelf</u>			
Wall Mounted	16	S.S.	4
Fixture Mounted	16	S.S.	4
Table	16	S.S.	4
Refrigerator		S.S. Wire	4
<u>Shelf Bracket (Exposed)</u>	14	S.S.	4
<u>Ducts</u>			
Exposed	16	S.S.	4-Weld
Dishmachine	20	S.S.	4-Weld
<u>Wall Flashing</u>	20	S.S.	4
<u>Equipment Legs & Cross Rails</u>	16	1-5/8"	4
		diameter	
		S.S. tubing	

O. Closure

Backs of all fixtures, splashback, shelves, etc., shall be closed.

P. Casters

Casters shall be heavy-duty, non-marking ball-bearing NSF approved type with greaseproof neoprene or polyurethane tires. Wheels shall be 5" (130 mm) diameter. Minimum width treads of 1-3/16" (30 mm). minimum capacity per caster 250 lbs. (115 Kg).

Q. Sinks

1. Fabricated sinks shall have corners same as for metal tops. One piece welded construction with bottom pitched to drains and double wall partitions. Multiple compartments shall have continuous exteriors. Openings between compartments or applied panel will not be accepted.

2. Sink insets shall be 16-gauge stainless steel welded as integral part of top.

R. Drawers

All drawer pans shall be 18-gauge stainless steel having all corners coved except where specifically noted otherwise. Pan to be mounted on fabricated 14-gauge stainless steel angel cradle frame. Frame to be supported on Component Hardware S52 or approved equal full extension slides with 200 lbs. (91 kg) capacity per pair. Pan to be easily removable without the use of tools. Drawer fronts shall be double pan type with sound deadening material. Drawer shall be self-closing.

S. Doors

1. All metal doors to be double pan type reinforced and stiffened to prevent flexing and filled with sound deadening material.
2. Sliding doors shall be mounted on large ball-bearing quiet rollers in 14-gauge stainless steel overhead tracks and be removable without the use of tools. Sliding doors shall be self-closing.
3. Hinged doors shall be flush type, mounted on heavy duty, stainless steel, lift-off hinges, or as specified.
4. When specified, pulls shall be Component Hardware P62-1010 or approved equal.

T. Hardware

1. All hardware shall be of heavy-duty construction and identified on shop drawings by manufacturer and model number and shall be subject to final approval by Designer.
2. All hardware shall be identified with manufacturer's name and model number so that broken or worn parts may be replaced.

U. Breaker Strips

All ice pans, ice bins, refrigerated pans and cabinets shall be provided with breaker strips where adjoining top or cabinet face materials to prevent condensation. Breaker strips shall be fastened with stainless steel, counter sunk screws. Pop rivets will not be acceptable.

V. Insulation

All refrigerator insulation shall be foamed in place polyurethane. Fiberglass insulation shall not be used. Heated areas shall have minimum of 1" (25 mm) of thick fiberglass/mineral wool 2-1/2" (62 mm) density blanket insulation. Cold areas shall be 1" (25 mm) thick as indicated on details or drawings. Insulation shall be bonded to all surfaces.

W. Refrigerated Items

1. All custom fabricated units to meet NSF-7 criteria.
2. All reach-in refrigerators and freezers with remote refrigeration systems shall be complete with thermostatic expansion valves at the evaporator.

3. Fabricated compartments, refrigerated shelves, plates, etc., shall be provided with a 20-gauge steel box to house expansion valves when valve is remote from evaporator. Install in base of fixtures or in a concealed position.
4. All refrigerated compartments shall be fitted with dial or digital type thermometers with chrome-plated bezels. Thermometers shall be adjustable and shall be calibrated after insulation.
5. Refrigerator hardware for fabricated refrigerator compartments shall be heavy-duty components. Hinges shall be self-closing. Latches to be magnetic edge mount type with cylinder lock unless specified or noted.
6. Refrigerated drawers shall be sized to accommodate two (2) 12" x 20" x 5" (Gastronorm 1/1) steam table pans side by side or as specified or shown on the drawings. Drawer pulls shall be Component Hardware Group, Inc. Model No. P60-1010 or as shown on the drawings. Drawer slides shall be Component Hardware Group S52 Series, 200 pound (91 Kg) capacity, with stainless steel bearings of length as required to suit drawer depth. Drawer front shall be double pan with 18-gauge stainless steel front insulated core and 20-gauge stainless steel back panel. Drawer frame shall be 14-gauge stainless steel.
7. Refrigerator door openings shall be sized to suit 18" x 26" bun pan or as specified or shown on the drawings.
8. Refrigerated bodies shall have extruded snap-on matte gray breaker strip at door and ingredient pan openings. Provide Component Hardware Group PTC T12-5000 Condensate Evaporator complete with wall mounting hardware.
9. Shelves shall be stainless steel wire installed on stainless steel removable keyhole type pilasters.

2.6 MILLWORK EQUIPMENT – N/A

2.7 STANDARD DETAILS

Standard Details included as part of drawings are to be considered guides to quality and scope of work involved. Where shop practices dictate, alternate construction methods and component items of equal manufacturer may be substituted. It will be the responsibility of the Kitchen Equipment Contractor to prove the quality of the proposed methods.

PART 3 - EXECUTION

3.1 DELIVERY AND INSTALLATION

A. Delivery

1. The equipment shall be delivered and installed on schedule. Coordinate all work with the General Contractor and other divisions as required.
2. Extra charges resulting from special handling or shipment shall be paid by the Kitchen Equipment Contractor if insufficient time was allowed in placing factory orders to ensure normal shipment.

- B. The work shall be accomplished so as not to delay the project construction schedule, interfere or conflict with the work being performed by other contractors. Work shall be coordinated and

integrated to prevent conflict of work necessitating changes to work already completed. Should conflicts occur, notify the Owner for his coordination in its resolution.

- C. Verify all field dimensions before fabrication.
- D. Include all alterations to walls, floors and ceiling necessary for work, except otherwise shown or specified, accomplished in a manner satisfactory to the Architect and the Designer. Holes through structural beams shall be prohibited unless written approval has been granted by the Architect.
- E. Cut holes in equipment for pipes, drains, electric outlets, etc. as required for this installation. Work shall conform to highest standards of workmanship and shall include welded sleeves, collars, ferrules or escutcheons.
- F. Repair all damage to the premises as a result of this installation.
- G. Remove daily all debris from the site related to this installation.
- H. Remove any plates, components or component covers installed at the factory before installing the FRP-X panels at cold storage rooms and reinstall them afterwards along with the items furnished loose for mounting on the exterior face of the wall panels.
- I. Space between all equipment to wall, ceiling, floors, masonry pads, and adjoining units not portable and with enclosed bodies shall be completely sealed against entrance of food particles or vermin by means of trim strips, welding, soldering or mastic. Mastic shall be General Electric Silicone Construction Sealant Series SE1200 in appropriate color.
- J. Trade marks and names of fabricator shall not be fastened to any items without the written approval of Clevenger Associates.
- K. All items shall be installed plumb, square, level and in proper elevation, plane location and in alignment with other work.

3.2 START-UP & DEMONSTRATION

- A. All equipment under this section shall be cleaned and ready for operation at time building is turned over to the Owner.
- B. Provide a competent service representative to be present when installation is put into operation. He shall lubricate and put into proper operation all equipment and instruct the Owner's employees in the proper use and maintenance of all items in this contract and set up a maintenance schedule to be followed thereafter. Three (3) copies of the schedule shall be provided before final acceptance of the installation.
- C. During start-up provide all required instruction for operation and maintenance of equipment, after one (1) year guarantee period.
- D. The fire suppression system shall be tested for the authorities in the Owner's presence. Certificates shall be obtained and provided to the Owner from the authorities and from the Fire Insurance Rating Bureau.
- E. After installation and hook-up, verify air volumes at each exhaust and make-up air duct. A report shall be submitted to the Owner of all readings. All incorrect air volumes shall be rechecked after adjustment.

3.3 MAINTENANCE SCHEDULE

- A. Provide operation and service inspections every ninety (90) days during the warranty period. Final inspection shall be performed thirty (30) days before warranty expiration. Any service or repair requirements shall be performed before the end of the warranty period.
- B. Copies of all warranty service calls and inspection reports shall be mailed to the Owner and Building Operations Engineer.
- C. The Owner may call an outside company at the expense of the Kitchen Equipment Contractor, if the Kitchen Equipment Contractor does not arrive within a reasonable amount of the called in response to an emergency call.

PART 4 - EQUIPMENT

4.1 REGULAR MANUFACTURED EQUIPMENT

- A. Provide equipment with standard finishes and accessories unless specifically deleted or superseded by the Contract Documents.

4.2 FABRICATED EQUIPMENT

- A. Provide arrangement and configuration as shown on plans, elevations and standard detail drawings.

4.3 FOODSERVICE EQUIPMENT SCHEDULE

Item No.	Qty	Description
01	1	WALL SHELF (PHASE 1)
02	1	CLEAN DISHTABLE (PHASE 1)
03	1	DISHWASHER WITH BOOSTER HEATER (VENTLESS) (PHASE 1)
04	1	SOILED DISHTABLE ASSEMBLY (PHASE 1)
05	3	HAND SINK (PHASE 1)
06	1	EYE WASH STATION (PHASE 1)
07	1	SERVING COUNTER (PHASE 2)
08	2	FOOD SHIELD (PHASE 2)
09	2	HOT/COLD PAN (DROP-IN) (PHASE 2)
10	1	ICE MACHINE (PHASE 1) (BY OWNER)
11	1	2-DOOR REACH-IN REFRIGERATOR (PHASE 1)
12	12	SERVING / FOOD PREP TABLES (PHASE 1) (BY OWNER)
13	2	MOBILE POT SHELVING (PHASE 1)
14	1	POT WASHING SINKS (PHASE 1)
15	1	UTENSIL RACK WITH SHELF (PHASE 1)

16	1	MOP SINK CABINET (PHASE 1)
17	2	TABLE MOUNTED OVERSHELF WITH POT RACK (PHASE 2)
18	2	ISLAND WORKTABLE (PHASE 2)
19	1	MOBILE TRAY RACK (PHASE 2)
20	2	WORKTABLE (PHASE 2)
21	4	WALL SHELF (PHASE 2)
22	1	EXHAUST HOOD WITH MAKE-UP AIR (TYPE 1) (PHASE 1)
23	1	STAINLESS STEEL WALL FLASHING (PHASE 1)
24	1	MOBILE GRIDDLE WITH OVEN (PHASE 2)
25	1	MOBILE (6) O/B RANGE WITH OVEN (PHASE 2)
26	1	MOBILE CONVECTION OVEN (PHASE 1)
27	1	FIRE SUPPRESSION SYSTEM (PHASE 1)
28	3	32-GALLON WASTE/RECYCLING BIN (PHASE 1) (BY OWNER)
29	1	SPARE NUMBER
30	1	WORKTABLE WITH SINK (PHASE 2)
31	1	WORKTABLE (PHASE 2)
32	5	WALL SHELVING (PHASE 2)
33	1	WORKTABLE WITH SINKS (PHASE 2)
34	1	SPARE NUMBER
35	5	DRY STORAGE SHELVING (PHASE 1)
36	2	MOBILE REACH-IN REFRIGERATOR (PHASE 2)
37	2	MOBILE REACH-IN FREEZER (PHASE 1 – EXISTING) (PHASE 2 - NEW)
38	3	STAINLESS STEEL WALL GUARD (PHASE 1)
39	1	MILLWORK COUNTERTOP (PHASE 1) (BY ARCHITECT)

4.4 FOODSERVICE EQUIPMENT ITEMIZED

ITEM 01: WALL SHELF (PHASE 1)
 Quantity: One (1)
 Manufacturer: Custom Fabricate

1. Fabricate in accordance with the General and Specific Conditions of these Specifications, as shown on the drawings and as follows:
 - a. Shelves shall be 3'-6" long x 1'-0" deep.
 - b. Provide one (1) mounted at 4'-6" above finish floor. Turn ends up matching upturned back, weld and polished joints.

- c. See Standard Detail C-1-2.

ITEM 02: CLEAN DISHTABLE (PHASE 1)
Quantity: One (1)
Manufacturer: Custom Fabricate

1. Fabricate in accordance with the General and Specific Conditions of these Specifications, as shown on the drawings and as follows:
 - a. Dishtable shall be 5'-0" x 2'-6" x 3'-1" high.
 - b. Dishtable to accommodate Item 03, Dishwasher with Booster Heater (Ventless) (Phase 1).
 - c. Provide backsplash as shown on drawings.
 - d. Full length bottom shelf below.
 - e. See Standard Details C-1-1 (G), C-1-1A (2) and C-8-1.

ITEM 03: DISHWASHER WITH BOOSTER HEATER (VENTLESS) (PHASE 1)
Quantity: One (1)
Manufacturer: Hobart
Model: AM16VLT-ADV-2

1. Ventless Dishwashing Machine, tall chamber (27") door type, energy recovery, automatic soil removal (ASR), drain water energy recovery (DWER), high temp sanitizing, 208-240/60/3 (field convertible to single phase), internal condensing system, 38 racks/hour, straight-thru or corner installation, user-friendly smart touchscreen controls, Sense-A-Temp™ booster, electric tank heat, X-shaped wash arms, scrap screen and basket, door actuated start, door lock, stainless steel tank, tank shelf, chamber, trim panels, frame & feet, pumped drain air gap, drain water tempering, cULus, NSF, ENERGY STAR®. Factory Startup - Free for installations within 100 miles of a Hobart Service Office during normal business hours with appropriate notice; installation beyond 100 miles will be quoted by Service. Unit to be complete with all standard components and/or accessories including the following:
 - a. Dishwasher shall be corner operation, extended chamber height.
 - b. ASR Left Hand Conversion Kit Installation – to relocate the ASR from the right to left side of the unit. Must be installed by Hobart Service
 - c. Accessory Installation - for installation within 100 miles of a Hobart Service Office during normal business hours with appropriate notice; installation beyond 100 miles will be quoted by Service. Includes installation of this item only, final electrical or plumbing connections by others. Recommendation: coordinate accessory installation with machine assembly/ installation (NET)
 - d. Provide 70° F rise built in electric booster heater.
 - e. Water Hammer Arrestor – Assembly includes ¾" brass pressure regulator, pressure gauge, shock arrestor and garden hose adapter
 - f. Provide additional Combination Rack and Peg Rack.

ITEM 04: SOILED DISHTABLE ASSEMBLY (PHASE 1)
Quantity: One (1)
Manufacturer: Custom Fabricate

1. Fabricate in accordance with the General and Specific Conditions of these Specifications, as shown on the drawings and as follows:
 - a. Dishtable shall be 9'-8" x 2'-6" x 3'-1" high to include: one (1) 1'-6" x 1'-6" x 7" deep pre-rinse sink with removable rack guide with one (1) Type 11 Pre-Rinse Faucet and one (1) Type 1 Drain.
 - b. Dishtable to accommodate Item 03, Dishwasher with Booster Heater (Ventless) (Phase 1).
 - c. Provide back splash as shown on drawings.
 - d. Bottom shelf below.
 - e. See Standard Details C-1-1 (G), C-1-1A (2), C-8-1 and C-8-10.

ITEM 05: HAND SINK (PHASE 1)
Quantity: Three (3)
Manufacturer: Advance Tabco
Model: 7-PS-40

1. Hand Sink, wall mounted, 14" wide x 10" front-to-back x 5" deep bowl, 20 gauge 304 stainless steel, 7-3/4" high side splashes, with splash mounted faucet, lever drain with overflow, P-trap, wall bracket, NSF, cCSAus. Unit to be complete with all standard components and/or accessories.

ITEM 06: EYE WASH STATION (PHASE 1)
Quantity: One (1)
Manufacturer: Haws
Model: 7360BT-7460BT

1. Unit to be complete with all standard components and/or accessories including the following:
 - a. Line Strainer.

ITEM 07: SERVING COUNTER (PHASE 2)
Quantity: One (1)
Manufacturer: Custom Fabricate

1. Fabricate in accordance with the General and Specific Conditions of these Specifications, as shown on the drawings and as follows:
 - a. Counter shall be 22'-4" x 2'-6" x 3'-0" high.
 - b. Counter to accommodate Item 08, Food Shields (Phase 2).
 - c. Cutouts to accommodate Item 09, Hot/Cold Pan (Drop-In) (Phase 2).

- d. Open and intermediate shelves.
- e. Provide backsplash as shown on drawing.
- f. Provide stainless steel trim and splash at pass-thru opening as required, extending serving counter thru opening, 2" beyond finished wall, turn-down 2" and return to wall. Close-off ends. Coordinate with General Contractor pass thru opening and roll down door (if applicable).
- g. See Standard Details C-1-1(C), C-1-1A (1) and C-2-1.

ITEM 08: FOOD SHIELD (PHASE 2)
Quantity: Two (2)
Manufacturer: Premier Metal & Glass
Model: FM2N-A

- 1. CHOICE™ Adjustable Dual-Service Sneeze Guard, single sided guard with top shelf, tempered glass with polished edges, adjustable end panels, front mount, 1" OD round stainless support posts, NSF & cULus listed. Unit to be complete with all standard components and/or accessories including the following:
 - a. Shaped and sized as detailed on drawings, approximately 6'-0" long, to be mounted as part of Item 07, Serving Counters.
 - b. Unit to be installed as shown in 07, Serving Counter (Phase 2) as shown on drawings. Verify installation requirements with solid surface countertop.
 - c. Adjustable/Convertible self or operator service.
 - d. Provide custom powder coat finish at tubing, slide posts and fittings to remain stainless steel finish. Confirm powder coat color with Architect.

ITEM 09: HOT/COLD PAN (DROP-IN) (PHASE 2)
Quantity: Two (2)
Manufacturer: Low Temp Industries
Model: DI-QSCHP-4

- 1. QuickSwitch™ Hot/Cold/Freeze Food Well, drop-in, 64-3/4"W x 26-3/4"D x 21-16/25"H, 14ga stainless steel top, accommodates (4) 12" x 20" pan size, wired remote, individual wired remote digital controls for hot or cold operation, manifold drain, stainless steel top & wells, galvanized exterior, cUL, UL, UL EPH Classified (ANSI/NSF 4, ANSI/NSF 7). Unit to be complete with all standard components and/or accessories including the following:
 - a. Unit to be installed as shown in 07, Serving Counter (Phase 2) as shown on drawings. Verify installation requirements with solid surface countertop.
 - b. Controls to be mounted in apron on face of 07, Serving Counter (Phase 2) on operator side.
 - c. Five (5) year extended compressor warranty and two (2) year labor warranty.

ITEM 10: ICE MACHINE (PHASE 1) (BY OWNER)
Quantity: One (1)

1. This item is not included in this Part of the Work. Kitchen Equipment Contractor shall schedule and coordinate his work with that of the other trades to expedite the job progress.

ITEM 11: MOBILE REACH-IN REFRIGERATOR (PHASE 1)
Quantity: One (1)
Manufacturer: True
Model: STA2R-2S-HC

1. SPEC SERIES® Refrigerator, reach-in, two-section, (2) stainless steel doors with locks, cam-lift hinges, digital temperature control, (6) chrome shelves, LED interior lights, stainless steel front & sides, aluminum interior sides & walls, stainless floor & ceiling, 5" castors, R290 Hydrocarbon refrigerant, 1/2 HP, 115v/60/1-ph, 5.9 amps, NEMA 5-15P, cULus, UL EPH Classified, Made in USA, ENERGY STAR®. Unit to be complete with all standard components and/or accessories including the following:
 - a. Refrigerator shall have doors hinged as indicated on the drawings
 - b. Provide four (4) additional wire shelves.
 - c. Seven (7) year extended compressor warranty and five (5) year parts and labor warranty.

ITEM 12: SERVING / FOOD PREP TABLE (PHASE 1) (BY OWNER)
Quantity: Twelve (12)

1. This item is not included in this Part of the Work. Kitchen Equipment Contractor shall schedule and coordinate his work with that of the other trades to expedite the job progress.

ITEM 13: MOBILE POT SHELVING (PHASE 1)
Quantity: Two (2)
Manufacturer: Metro
Model: Metromax Q

1. Unit to be complete with all standard components and/or accessories including the following:
 - a. Shelving shall be sized as indicated on the plan.
 - b. Section shall consist of four (4) posts and four (4) shelves.
 - c. Posts shall be MQ74UPE.
 - d. Bottom shelf shall be set 10" above finish floor line and the three (3) remaining shelves equally spaced.
 - e. Provide two (2) Model 5MPXGSA, and two (2) Model 5MPBXGSA, casters per unit.

ITEM 14: POT WASHING SINKS (PHASE 1)
Quantity: One (1)
Manufacturer: Custom Fabricate

1. Fabricate in accordance with the General and Specific Conditions of these Specifications, as shown on the drawings and as follows:

- a. Sink assembly shall be 10'-9" x 2'-6" x 3'-1" high to include: three (3) 2'-3" x 2'-0" x 1'-2" deep wash, rinse and sanitize sinks with one (1) Type 13 Pre-Rinse Faucet, one (1) Type 2 Faucet and three (3) Type 4 Drains.
- b. Provide back and side splashes as shown on drawing.
- c. Bottom shelf below each drainboard.
- d. See Standard Details C-1-1 (G), C-1-1A (2), C-8-1 and C-8-5.

ITEM 15: UTENSIL RACK WITH SHELF (PHASE 1)
Quantity: One (1)
Manufacturer: Custom Fabricate

1. Fabricate in accordance with the General and Specific Conditions of these Specifications, as shown on the drawings and as follows:
 - a. Rack shelf shall be 5'-0" long mounted at +6'-6" AFF.
 - b. See Standard Detail C-7-4A (Type "1").

ITEM 16: MOP SINK CABINET (PHASE 1)
Quantity: One (1)
Manufacturer: John Boos
Model: PBJC-303084

1. Janitor Cabinet, 30"W x 30"D x 84"H overall size, enclosed cabinet with open back for plumbing, (2) lockable louvered swing doors, includes 24" x 24" x 12" deep mop sink with drain, overhead shelf, rear-mounted mop holder with (3) locking cams, service faucet with vacuum breaker and 120" hose, 18/300 stainless steel, NSF. Unit to be complete with all standard components and/or accessories.

ITEM 17: TABLE MOUNTED OVERSHELF WITH POT RACK (PHASE 2)
Quantity: Two (2)
Manufacturer: Custom Fabricate

1. Fabricate in accordance with the General and Specific Conditions of these Specifications, as shown on the drawings and as follows:
 - a. Shall be 4'-8" long.
 - b. Shall be fabricated as part of Item 18, Island Worktables (Phase 2).
 - c. See Standard Detail C-7-5 (similar).

ITEM 18: ISLAND WORKTABLE (PHASE 2)
Quantity: Two (2)
Manufacturer: Custom Fabricate

1. Fabricate in accordance with the General and Specific Conditions of these Specifications, as shown on the drawings and as follows:
 - a. Worktable shall be 5'-0" x 2'-6" x 3'-0" high.

- b. Worktable to accommodate Items 17, Table Mounted Overshelf with Pot Rack (Phase 2).
- c. Full length bottom shelf below.
- d. See Standard Details C-1-1(C) and C-7-1.

ITEM 19: MOBILE TRAY RACK (PHASE 2)
Quantity: One (1)
Manufacturer: Cres Cor
Model: 207UA13A

- 1. Rack, Mobile Utility, full height, open sides, (13) universal slides on 4-1/2" centers, multi-purpose, adjustable at 1-1/2" intervals, welded extruded aluminum frame, end loading, (4) 5" swivel polyurethane casters (2) braked, NSF. Unit to be complete with all standard components and/or accessories including the following:
 - a. Pan Stop, mounted to rear, prevents accidental push through of pans.
 - b. Provide perimeter bumpers.
 - c. Push Handle, with donut bumpers for racks.

ITEM 20: WORKTABLE (PHASE 2)
Quantity: Two (2)
Manufacturer: Custom Fabricate

- 1. Fabricate in accordance with the General and Specific Conditions of these Specifications, as shown on the drawings and as follows:
 - a. Table shall be 3'-0" x 2'-6" x 3'-0" high.
 - b. Full length bottom shelf below.
 - c. Provide back splash as shown on drawing.
 - d. See Standard Details C-1-1 (C) and C-7-1.

ITEM 21: WALL SHELF (PHASE 2)
Quantity: Four (4)
Manufacturer: Custom Fabricate

- 1. Fabricate in accordance with the General and Specific Conditions of these Specifications, as shown on the drawings and as follows:
 - a. Shelf shall be 3'-0" long x 1'-0" deep.
 - b. Provide two (2) at 4'-6" above finish floor and two (2) at 5'-6" above finish floor. Turn ends up matching upturned back, weld and polished joints.
 - c. See Standard Detail C-1-2

ITEM 22: EXHAUST HOOD WITH MAKE-UP AIR (TYPE 1) (PHASE 1)
Quantity: One (1)
Manufacturer: Gaylord

Model: ELX Series

1. Unit to be complete with all standard components and/or accessories including the following:
 - a. Overall length 11'-0".
 - b. Ventilation section shall be high velocity type grease extractor with an air inlet opening above and parallel to the cooking surface. Ventilator to utilize full-length horizontal baffles for centrifugal grease extraction.
 - c. Stainless steel construction, not less than 18-gauge, Type 304. All exposed surfaces shall be a Number 4 finish, including closure panels to finished ceiling as required.
 - d. Ventilator to be factory pre-plumbed and pre-wired.
 - e. Approvals to include U.L. listed under the category "Grease Extractors for Exhaust Ducts", and listed or recognized by BOCA, ICBO (refer to Research Report 2064), NSF (in Canada, ULS and CSA) and in accordance with all recommendations of NFPA's Standard No. 96.
 - f. Electrical: 120/60/1.
 - g. Provide four (4) LED light fixtures, installed and pre-wired.
 - h. Duct connection sizes, exhaust and supply CFM and static pressures shall be as indicated on Equipment Schedule and drawings and shall not exceed the same. (Maximum cooking surface temperature 700° F.)
 - i. No Capture Wall.
 - j. Ventilator to be pre-piped with all components required for "Ansul" Fire Suppression System, located in Item 27.
 - k. Automatic fan interlock as per local code.
 - l. Provide Light/Fan Switch, Room Temp. Sensor and Exhaust Hood Control Cabinet as required for the Auto Start Fan Systems, coordinate with the mechanical division.
 - m. After installation and hook-up, the Kitchen Equipment Contractor shall verify air volumes at each exhaust and air make-up air duct. A written report shall be submitted to the Owner of all readings. All incorrect air volumes shall be reported to the General Contractor for adjustments to be by the Mechanical Contractor. Incorrect air volumes shall be rechecked after adjustments.

ITEM 23: STAINLESS STEEL WALL FLASHING (PHASE 1)

Quantity: One (1)

Manufacturer: Custom Fabricate

1. Fabricate in accordance with the General and Specific Conditions of these Specifications, as shown on the drawings and as follows:
 - a. Flashing to run full length of Exhaust Hood Item 22, from top of cove base tile to underside of exhaust hood.

b. See Standard Detail C-2-11.

ITEM 24: MOBILE GRIDDLE WITH OVEN (PHASE 2)
Quantity: One (1)
Manufacturer: Garland
Model: C36-1-1R

1. Cuisine Series Heavy Duty Range, gas, 36", griddle, 1" thick steel plate, thermostatic controls, standard oven, includes (1) rack, 7"H backguard, stainless steel burner box, stainless steel front & sides, 130,000 BTU, CSA Flame, CSA Star, NSF. Unit to be complete with all standard components and/or accessories including the following:
 - a. Unit with oven base, provide one (1) additional oven rack.
 - b. 3/4" Rear gas connection, including end cap & cover.
 - c. Provide set of four (4) casters, two (2) with brakes.
 - d. 3/4" rear gas connection with pressure regulator and quick disconnect for gas line, restraining device and Safety-Sets as specified in Section 2.2, H of the Specific Conditions.

ITEM 25: MOBILE (6) O/B RANGE WITH OVEN (PHASE 2)
Quantity: One (1)
Manufacturer: Garland
Model: C36-6R

1. Cuisine Series Heavy Duty Range, gas, 36", (6) 35,000 BTU open burners, standard oven, includes (1) rack, 7"H backguard, stainless steel burner box, stainless steel front & sides, 250,000 BTU, CSA Flame, CSA Star, NSF. Unit to be complete with all standard components and/or accessories including the following:
 - a. Unit with oven base, provide one (1) additional oven rack.
 - b. 1" NPT, Rear gas connection, including end cap & cover.
 - c. Provide set of four (4) casters, two (2) with brakes.
 - d. 3/4" rear gas connection with pressure regulator and quick disconnect for gas line, restraining device and Safety-Sets as specified in Section 2.2, H of the Specific Conditions.

ITEM 26: MOBILE CONVECTION OVEN (PHASE 1)
Quantity: One (1)
Manufacturer: Garland
Model: MCO-GS-10M

1. Master Series Convection Oven, gas, single-deck, standard depth 39", (2) speed fan, 4.3" easyTouch digital control with simple Press&Go, Cook 'n' Hold, timers, & recipe functions, electric ignition, dependent 60/40 doors with windows, stainless steel front, sides & top, porcelain cavity, 24" cooking cavity height, with (6) chrome plated oven racks on 13-position rack guides, EnerLogic Technology, 60,000 BTU, UL, cUL, NSF. Unit to be complete with all standard components and/or accessories including the following:

- a. Provide one (1) extra oven rack.
- b. Stainless steel open cabinet base, shelf, and chrome plated rack support guides.
- c. Stainless steel removable drip pan, per deck.
- d. Casters, set of 4, for open cabinet base.
- e. ¾" rear gas connection with pressure regulator and quick disconnect for gas and water lines, restraining device and Safety-Sets as specified in Section 2.2, H of the Specific Conditions.

ITEM 27: FIRE SUPPRESSION SYSTEM (PHASE 1)
Quantity: One (1)
Manufacturer: Ansul
Model: R-102 WET

1. Unit to be complete with all standard components and/or accessories including the following:
 - a. Unit to meet UL Test Standards 300, NFPA Standards 17A and 96, and be a U.L. listed automatic wet chemical fire suppression system to provide protection for plenum and/or exhaust ducts and all grease-producing cooking surfaces located under canopy hood.
 - b. All piping, conduit, cable, etc. shall be concealed as applicable. All nozzles and exposed piping to be chrome-plated or stainless steel.
 - c. Size, number and location of nozzles, number of fusible links to be in accordance with U.L. limits for this particular system.
 - d. Manual control of the system shall be possible by actuation of remote release control (s).
 - e. Double-pole, double-throw, electric (snap action) switch assembly.
 - f. Cylinder (s) shall be rack mounted to wall in a stainless-steel enclosure.
 - g. Electrical/shunt-trip contactors required will be furnished and installed by the Electrical Contractor for actuation by the Ansul control devices.
 - h. Obtain permits and conduct test of system in the presence of the Contracting Officer and the agency having jurisdiction.

ITEM 28: 32-GALLON WASTE/RECYCLE BIN (PHASE 1) (BY OWNER)
Quantity: Three (3)

1. This item is not included in this Part of the Work. Kitchen Equipment Contractor shall schedule and coordinate his work with that of the other trades to expedite the job progress.

ITEM 29: SPARE NUMBER

ITEM 30: WORKTABLE WITH SINK (PHASE 2)
Quantity: One (1)

Manufacturer: Custom Fabricate

1. Fabricate in accordance with the General and Specific Conditions of these Specifications, as shown on the drawings and as follows:
 - a. Worktable with sink shall be 5'-0" x 2'-6" x 3'-0" high to include: one (1) 1'-8" x 1'-10" x 1'-0" deep sink with one (1) Type 1 Faucet and one (1) Type 1 Drain.
 - b. Provide back splash as shown on drawings.
 - c. Bottom shelf below left side.
 - d. See Standard Details C-1-1 (D), C-1-1A (2) and C-8-7.

ITEM 31: WORKTABLE (PHASE 2)

Quantity: One (1)

Manufacturer: Custom Fabricate

1. Fabricate in accordance with the General and Specific Conditions of these Specifications, as shown on the drawings and as follows:
 - a. Worktable shall be 6'-0" x 2'-6" x 3'-0" high.
 - b. Provide back splash as shown on drawings.
 - c. Full length bottom shelf below.
 - d. See Standard Details C-1-1 (C), C-1-1A (2) and C-7-1.

ITEM 32: WALL SHELVING (PHASE 2)

Quantity: Five (5)

Manufacturer: Metro

Model: Smartwall G3

1. Unit to be complete with all standard components and/or accessories including the following:
 - a. Provide three (3) model SW40K4 and two (2) model SW56K4 Smartwall G3 Wall Track. Field modified to be 36" and 48" long.
 - b. Provide ten (10) model SWU30K4 Smartwall G3 Upright.
 - c. Provide three (3) model WG1836K4 and two (2) WG1848K4 Smartwall G3 Wire Grid.
 - d. Provide twenty (20) model SWS14K4 Smartwall G3 Shelf Support.
 - e. Provide six (6) model 1436NK4 and four (4) model 1448NK4 Super Erecta Shelf.
 - f. Provide forty (40) model 9997C Shelf Collar Plug (Hole Plug).
 - g. Provide twenty-five (25) model HK23C Smartwall G3 Snap-On Hook.
 - h. Provide seven (7) model H210K4 Smartwall G3 Storage Basket.

- i. Secure grid to wall with factory approved fasteners. Provide wall backing.

ITEM 33: WORKTABLE WITH SINKS (PHASE 2)
Quantity: One (1)
Manufacturer: Custom Fabricate

1. Fabricate in accordance with the General and Specific Conditions of these Specifications, as shown on the drawings and as follows:
 - a. Worktable with sinks shall be 8'-0" x 2'-6" x 3'-0" high to include: two (2) 1'-8" x 2'-0" x 1'-0" deep sink with one (1) Type 1 Faucet and two (2) Type 1 Drains.
 - b. Provide back splash as shown on drawings.
 - c. Bottom shelf below each drainboard.
 - d. See Standard Details C-1-1 (D), C-1-1A (2) and C-8-7.

ITEM 34: SPARE NUMBER

ITEM 35: DRY STORAGE SHELVING (PHASE 1)
Quantity: Five (5)
Manufacturer: Metro
Model: Metromax Q

1. Unit to be complete with all standard components and/or accessories including the following:
 - a. Shelving shall be sized as indicated on the plan.
 - b. Section shall consist of four (4) posts and five (5) shelves.
 - c. Posts shall be MQ86PE.
 - d. Bottom shelf shall be set 10" above finish floor line and the four (4) remaining shelves equally spaced.

ITEM 36: MOBILE REACH-IN REFRIGERATOR (PHASE 1)
Quantity: Two (2)
Manufacturer: True
Model: STA2R-2S-HC

1. SPEC SERIES® Refrigerator, reach-in, two-section, (2) stainless steel doors with locks, cam-lift hinges, digital temperature control, (6) chrome shelves, LED interior lights, stainless steel front & sides, aluminum interior sides & walls, stainless floor & ceiling, 5" castors, R290 Hydrocarbon refrigerant, 1/2 HP, 115v/60/1-ph, 5.9 amps, NEMA 5-15P, cULus, UL EPH Classified, Made in USA, ENERGY STAR®. Unit to be complete with all standard components and/or accessories including the following:
 - a. Refrigerator shall have doors hinged as indicated on the drawings
 - b. Provide four (4) additional wire shelves.

- c. Seven (7) year extended compressor warranty and five (5) year parts and labor warranty.

ITEM 37: MOBILE REACH-IN FREEZER (PHASE 1) (BY OWNER)
Quantity: Two (2)

1. This item is not included in this Part of the Work. Kitchen Equipment Contractor shall schedule and coordinate his work with that of the other trades to expedite the job progress.
2. To be relocated as shown on plans in phase 2.

ITEM 37: MOBILE REACH-IN FREEZER (PHASE 2)
Quantity: Two (2)
Manufacturer: True
Model: STA2F-2S-HC

1. SPEC SERIES® Freezer, reach-in, two-section, -10°F, (2) stainless steel doors with locks, cam-lift hinges, digital temperature control, (6) chrome shelves, LED interior lights, stainless steel front & sides, aluminum interior, 5" castors, R290 Hydrocarbon refrigerant, 1-1/4 HP, 115v/60/1-ph, 9.4 amps, NEMA 5-15P, cULus, UL EPH Classified, Made in USA, ENERGY STAR®. Unit to be complete with all standard components and/or accessories including the following:
 - a. Freezer shall have doors hinged as indicated on the drawings.
 - b. Provide four (4) additional wire shelves.
 - c. Seven (7) year extended compressor warranty and five (5) year parts and labor warranty.

ITEM 38: STAINLESS STEEL WALL GUARD (PHASE 1)
Quantity: Three (3)
Manufacturer: Custom Fabricate

1. Fabricate in accordance with the General and Specific Conditions of these Specifications, as shown on the drawings and as follows:
 - a. Serving window - shall be shaped and sized as detailed on the drawings approximately 9'-0" long, 18 ga. Stainless Steel "U" shaped pass thru trim at both sides and header of opening.
 - b. Soiled Dish Pass Window - shall be shaped and sized as detailed on the drawings approximately 4'-0" long, 18 ga. Stainless Steel "U" shaped pass thru trim at both sides and header of opening.
 - c. Coordinate with General Contractor pass thru openings and roll down doors.

ITEM 39: MILLWORK COUNTERTOP (PHASE 1) (BY ARCHITECT)
Quantity: One (1)

1. This item is not included in this Part of the Work. Kitchen Equipment Contractor shall schedule and coordinate his work with that of the other trades to expedite the job progress.

4.5 FOODSERVICE STANDARD DETAILS

C-1-1	EDGE DETAILS
C-1-1A	BACKSPLASH DETAILS
C-1-2	EXPOSED BRACKET WALL MOUNTED OVERSHELF
C-2-1	SEMI-ENCLOSED COUNTER
C-2-11	FLASHING DETAIL
C-7-1	OPEN BASE TABLE
C-7-4A	WALL MOUNTED POT AND PAN RACK
C-7-5	TABLE MOUNTED UTENSIL RACK
C-8-1	CLEAN DISHTABLE AND DRAINBOARD
C-8-5	SINK ASSEMBLY/DISHTABLE SINK
C-8-7	MARINE EDGE SINK
C-8-10	PRE-RINSE SINK WITH REMOVABLE GUIDE

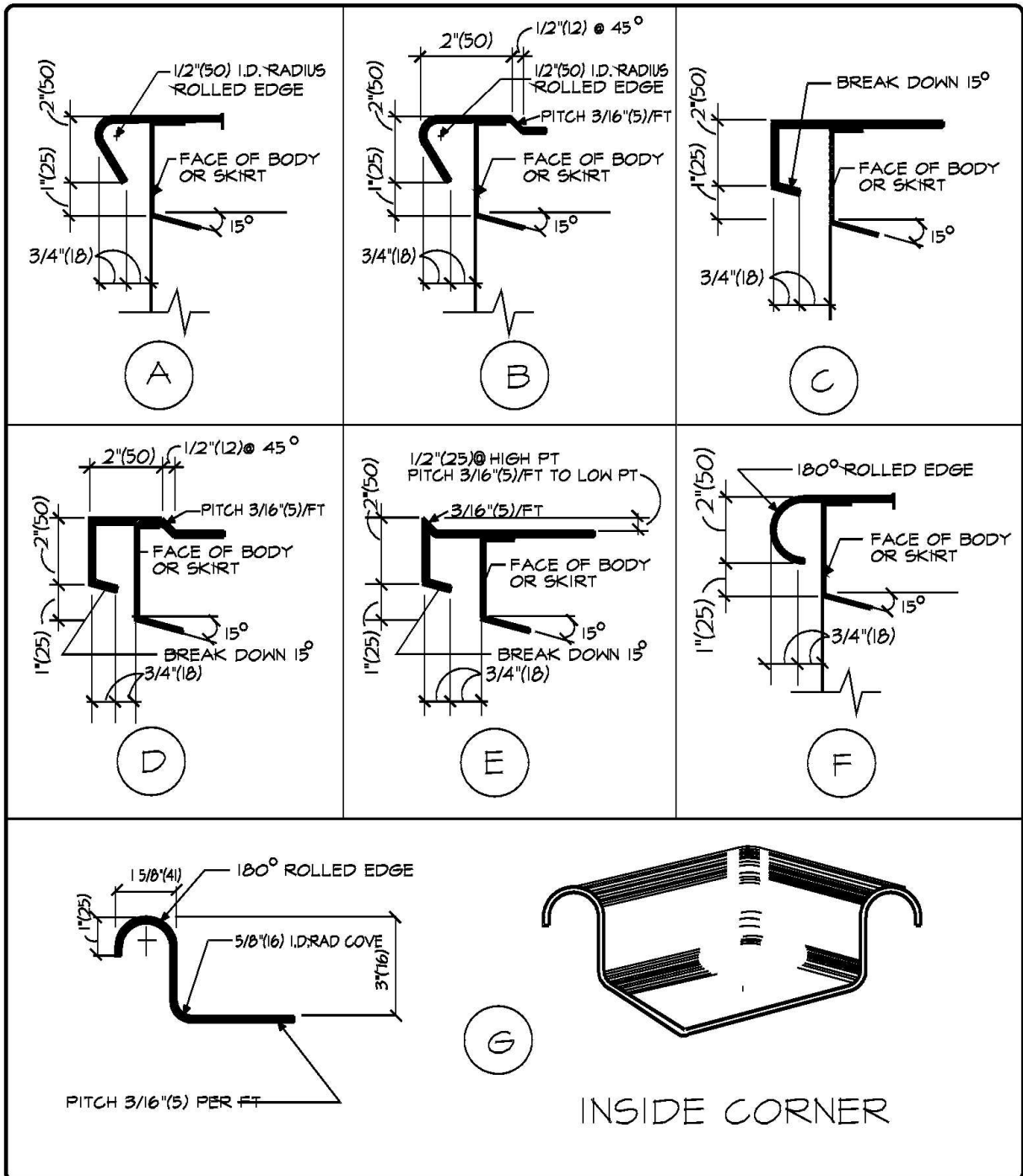

CLEVENGER ASSOCIATES

EDGE DETAILS
 C-1-1

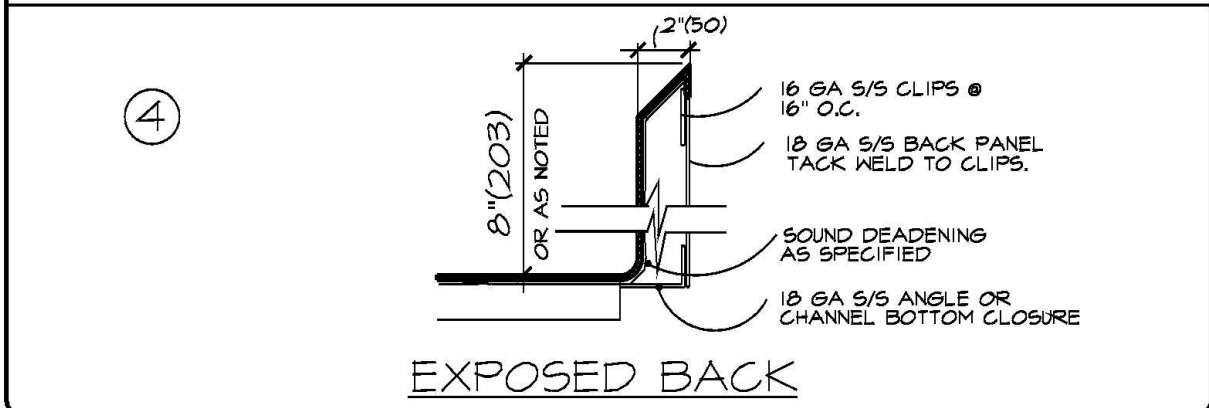
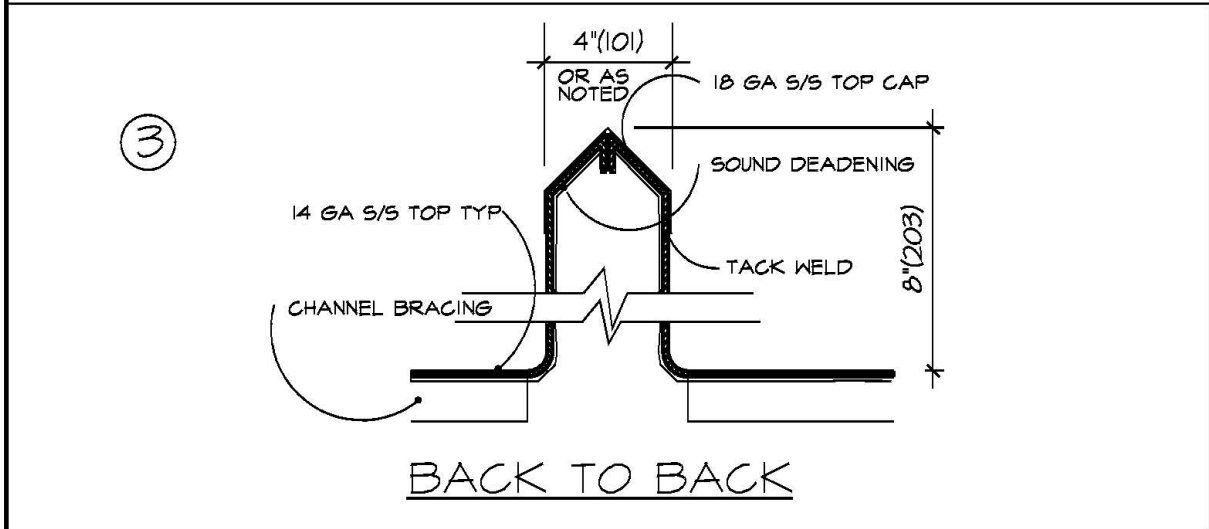
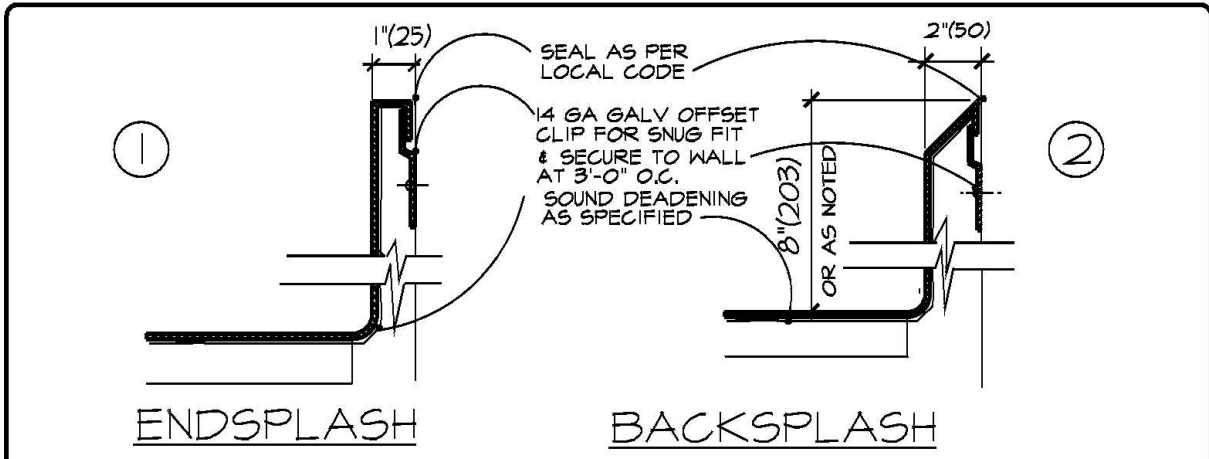

<p>CLEVENGER ASSOCIATES</p>	<p><u>BACKSPLASH DETAILS</u></p> <p>C-1-1A</p>
------------------------------------	---

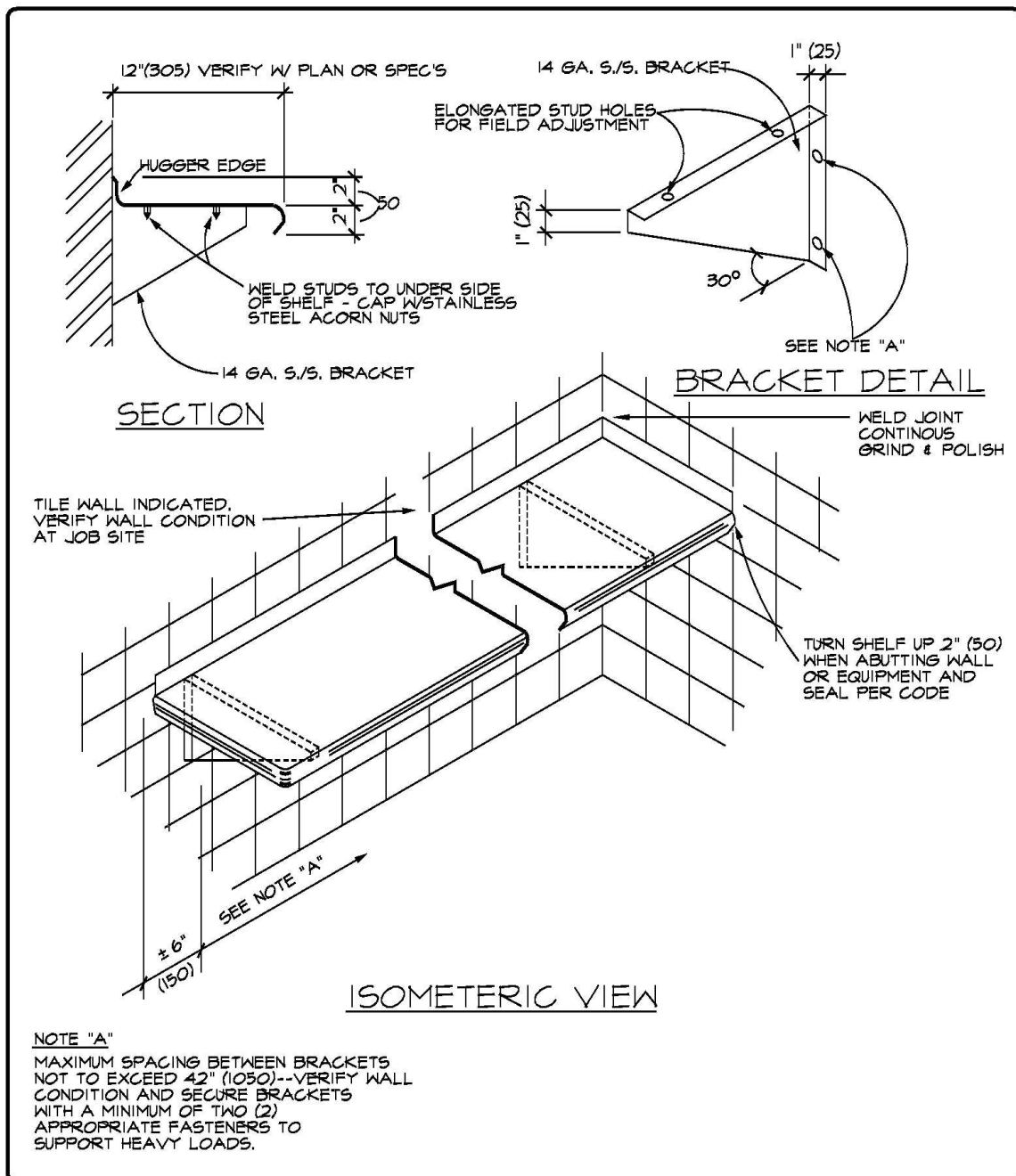

CLEVENGER ASSOCIATES

**EXPOSED BRACKET
 WALL MTD. OVERSHELF**

C-1-2

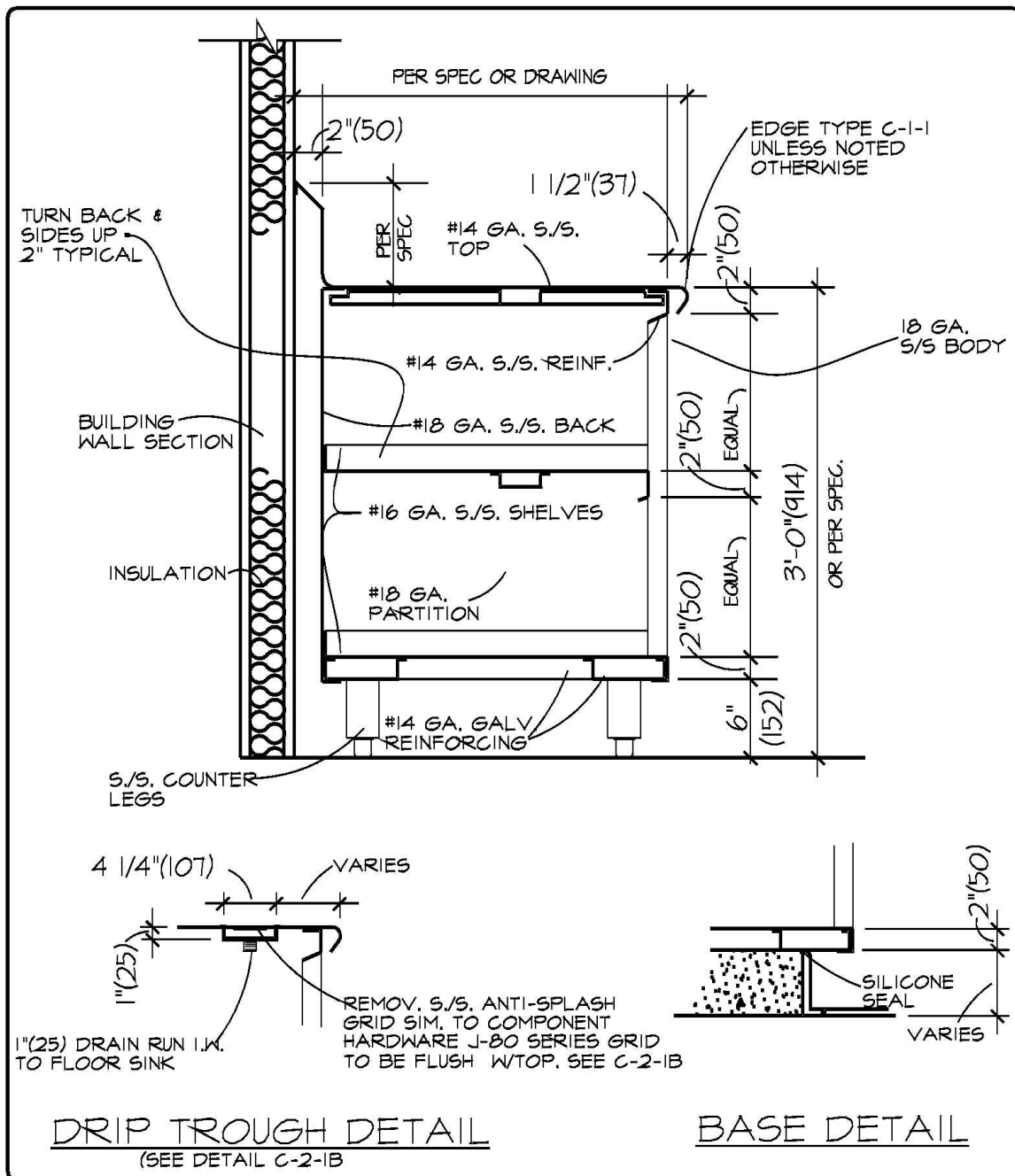

CLEVENGER ASSOCIATES

**SEMI-ENCLOSED
 COUNTER**

C-2-1

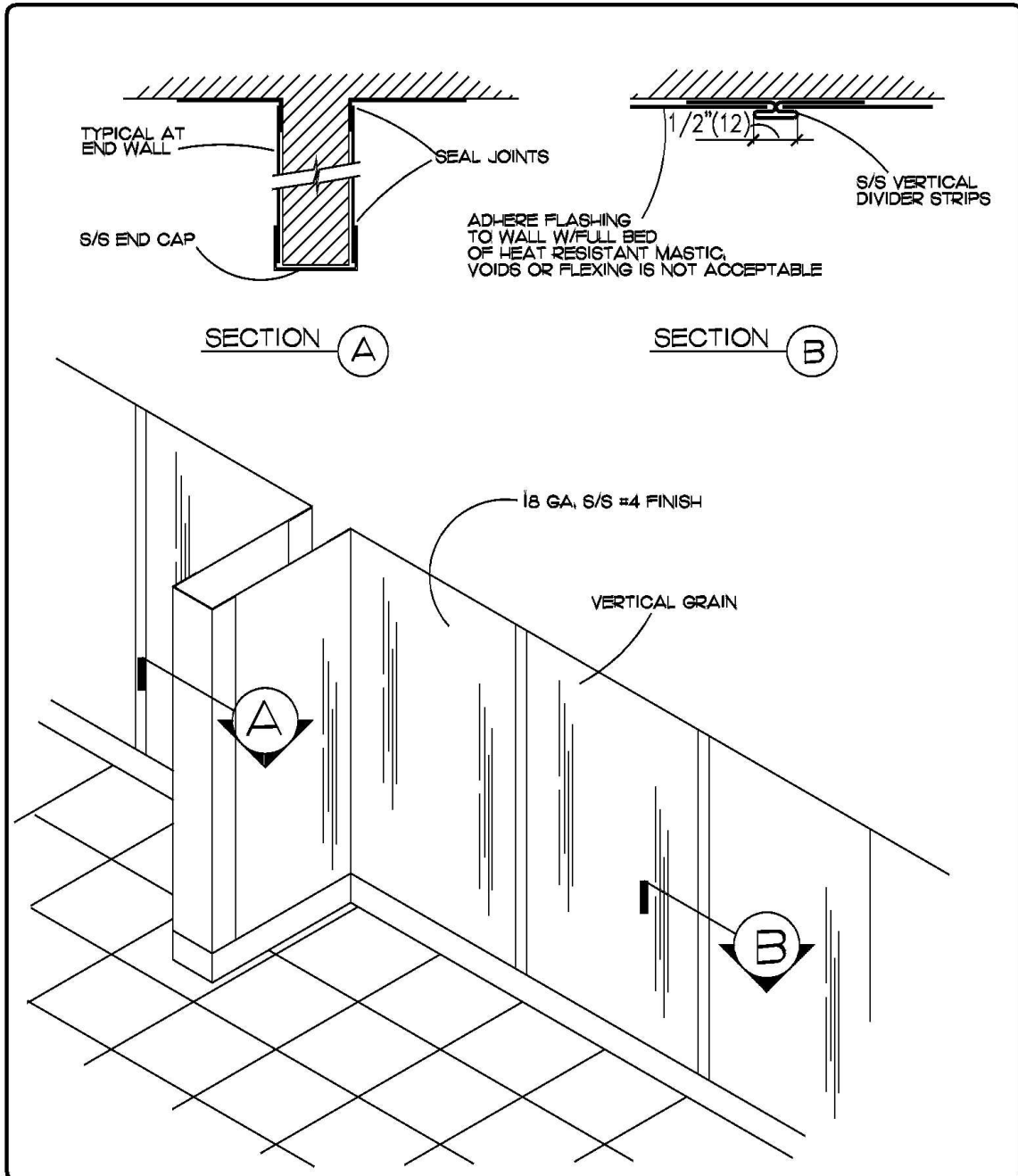

CLEVINGER ASSOCIATES	FLASHING DETAIL
	C-2-11

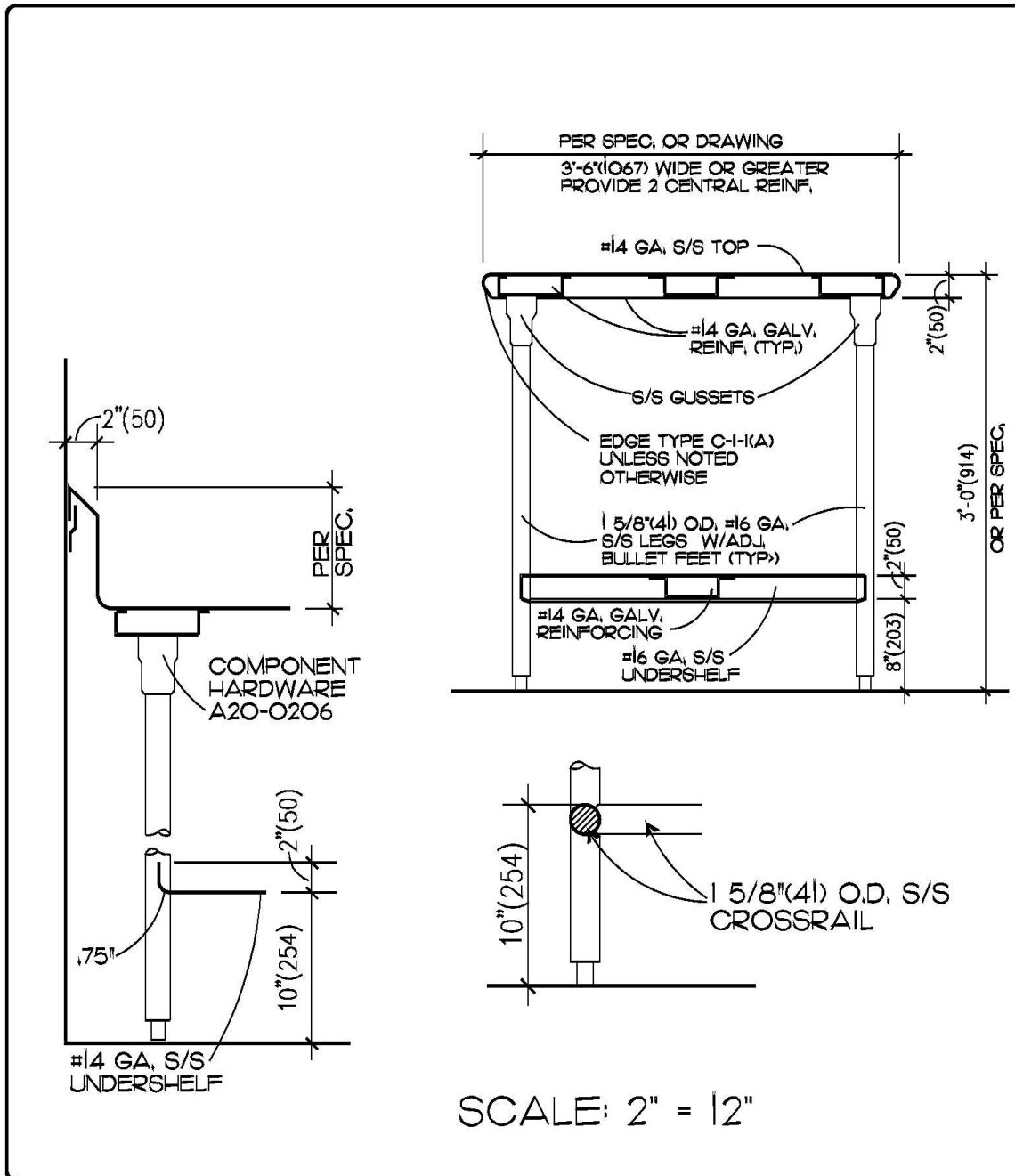

CLEVENGER ASSOCIATES

OPEN BASE TABLE

C-7-1

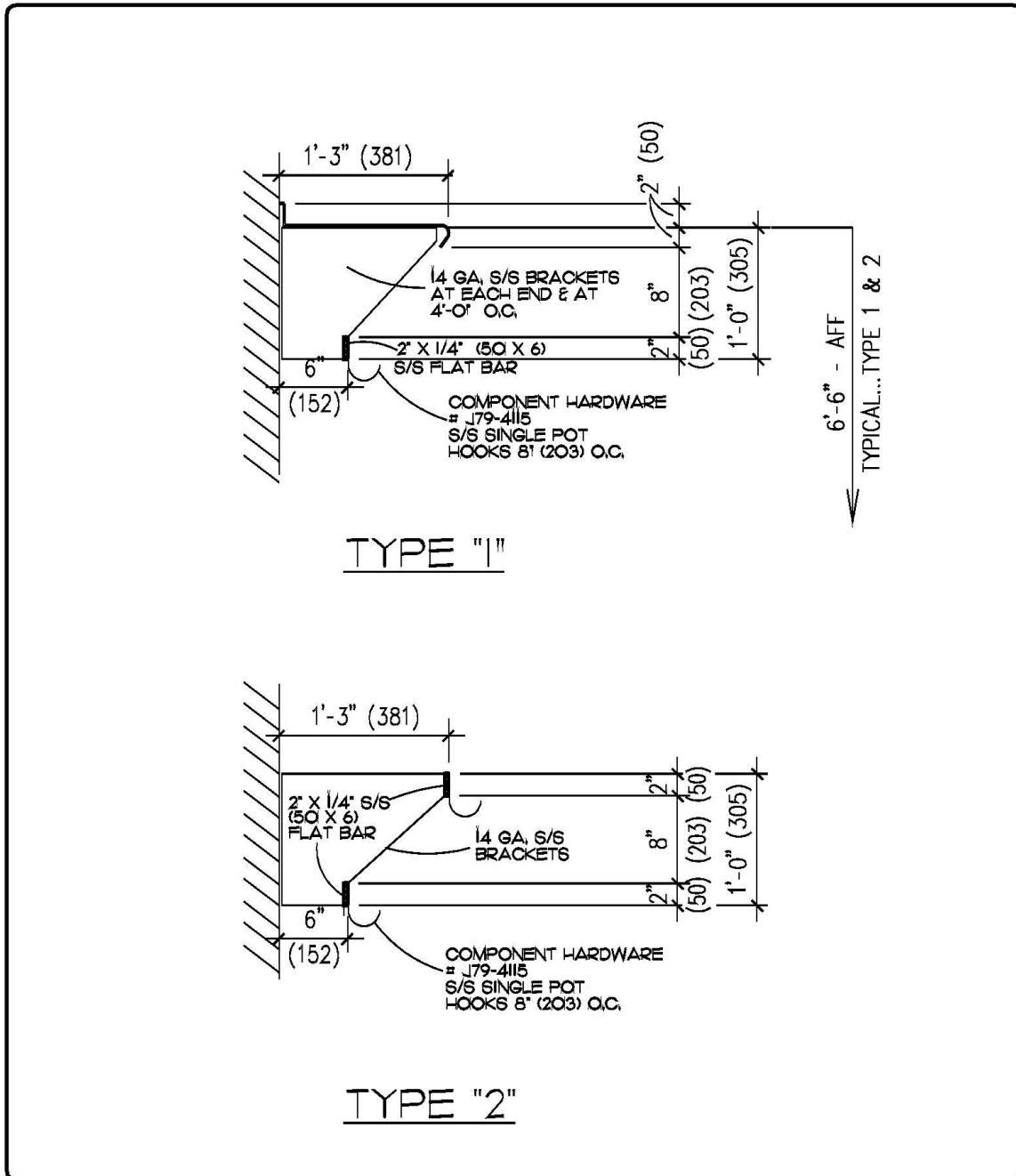

CLEVINGER ASSOCIATES	WALL MOUNTED POT AND PAN RACK
05/01	C-7-4A

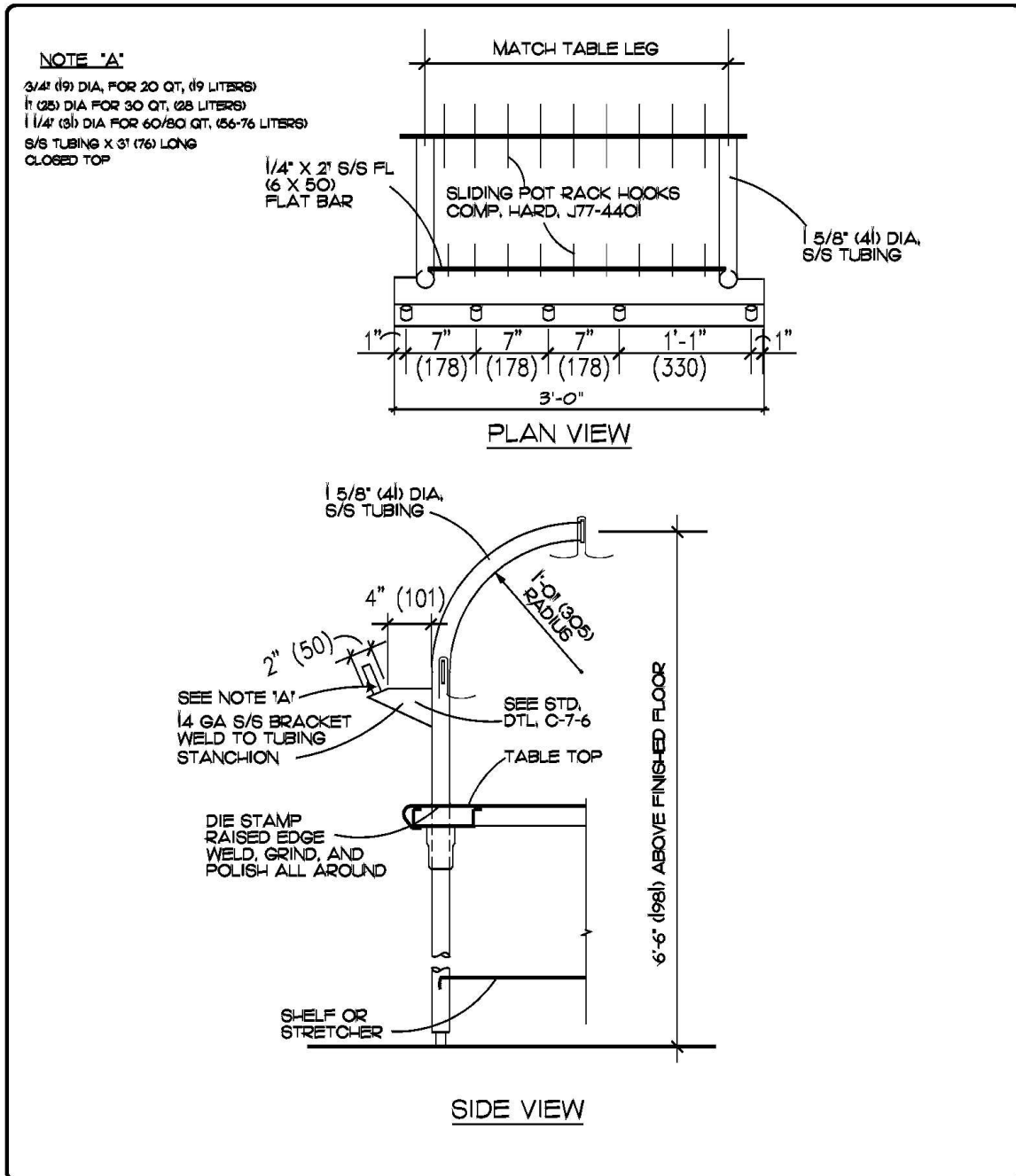

CLEVENGER ASSOCIATES	TABLE MOUNTED UTENSIL RACK
	C-7-5

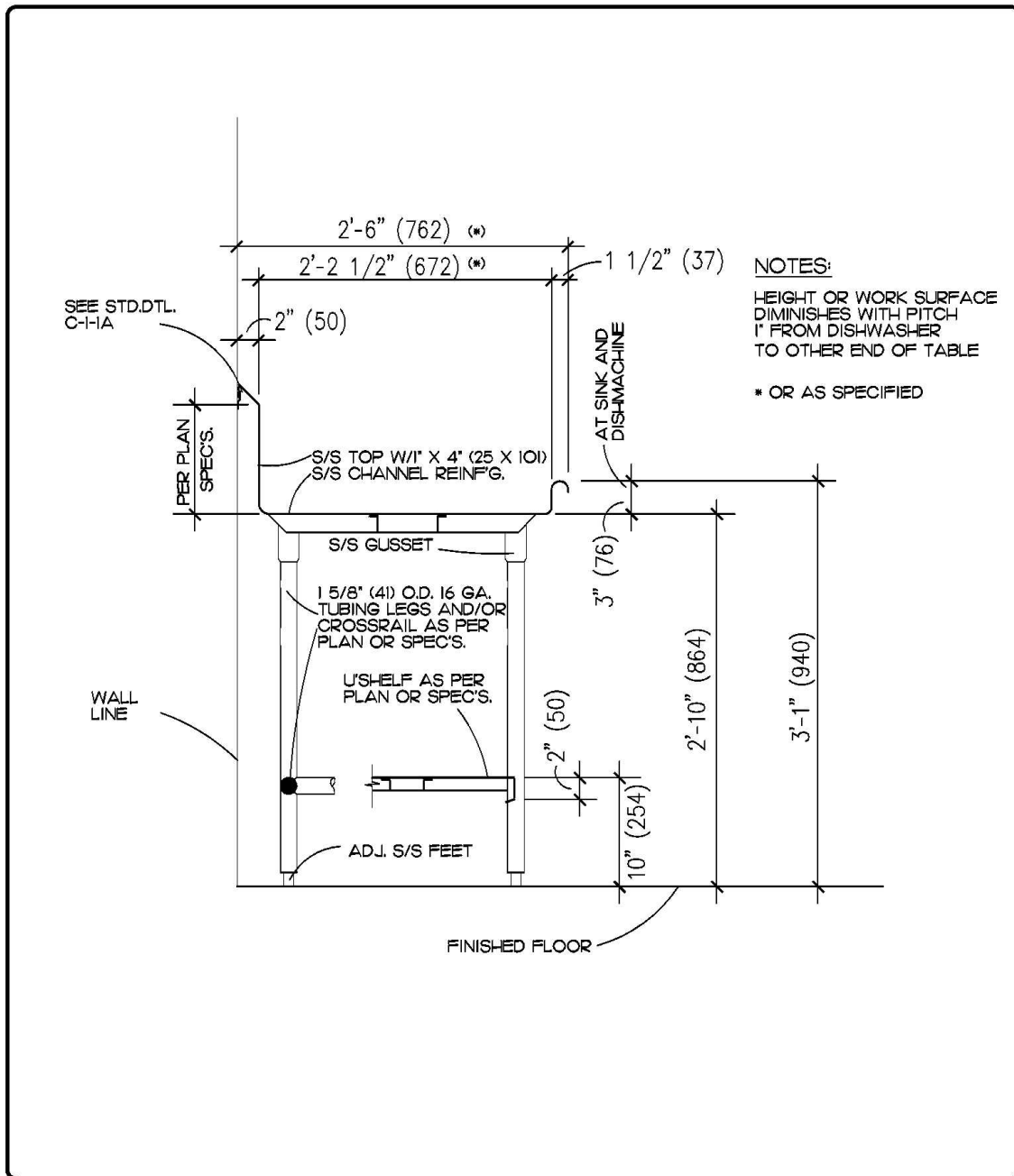

CLEVINGER ASSOCIATES	<u>CLEAN DISHTABLE AND DRAINBOARD</u>
	C-8-1

NOTES:

- OR AS SPECIFIED
- HEIGHT DIMINISHES W/PITCH-MINIMUM PITCH: 1/8"(3)/FT.

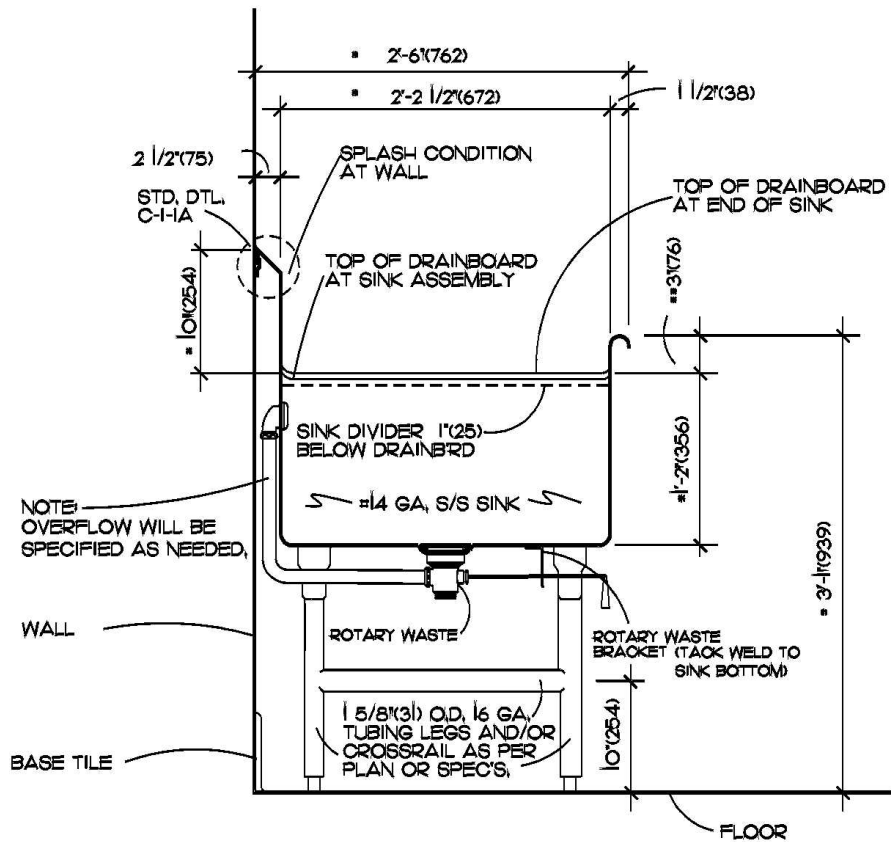
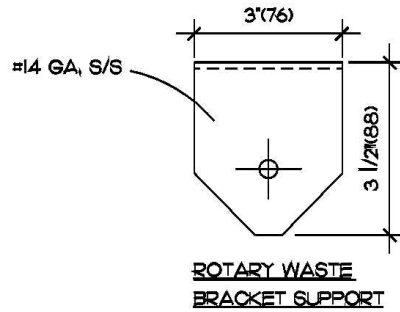

CLEVENGER ASSOCIATES

**SINK ASSEMBLY/
DISHTABLE SINK**

C-8-5

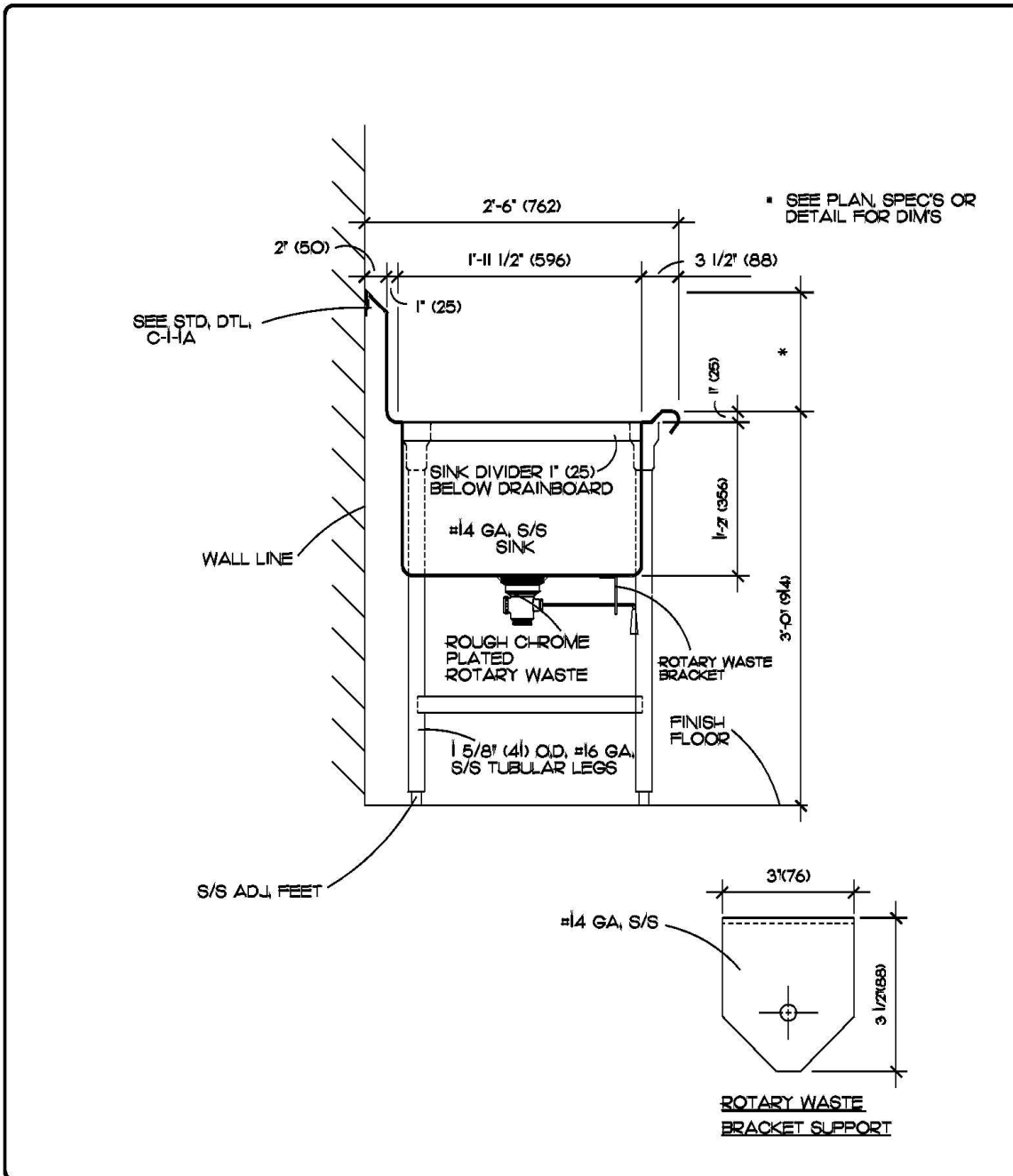

CLEVENGER ASSOCIATES

MARINE EDGE SINK

C-8-7

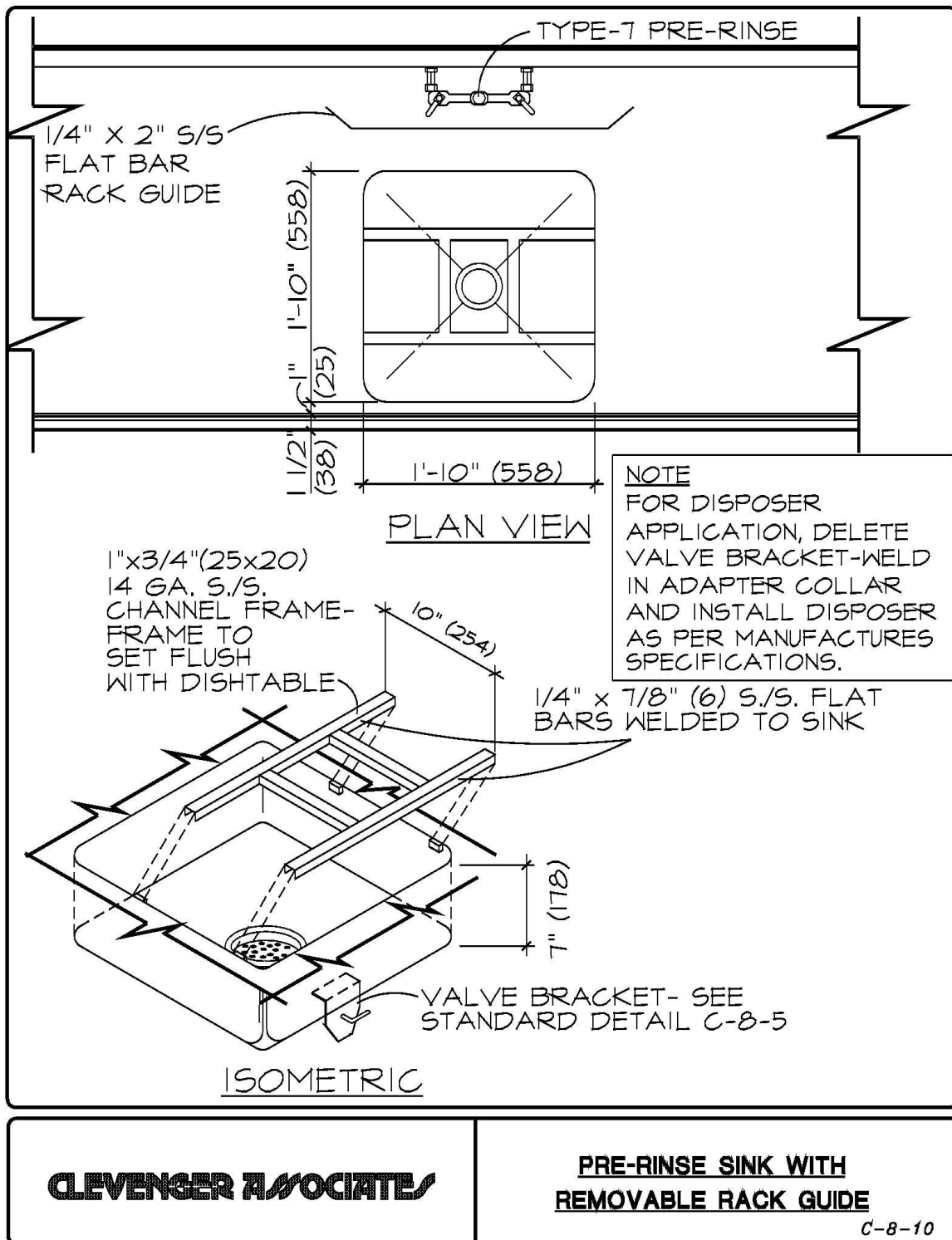

END OF SECTION 11 40 00

SECTION 23 34 00 - HVAC FANS

PART 1 GENERAL

1.1 SUMMARY

- A. Section Includes:
 - 1. Fans.

1.2 QUALITY ASSURANCE

- A. Performance Ratings: Conform to AMCA 210 and bear AMCA Certified Rating Seal.
- B. Sound Ratings: AMCA 301, tested to AMCA 300, and bear AMCA Certified Sound Rating Seal.
- C. UL Compliance: UL listed and labeled, designed, manufactured, and tested in accordance with UL 705.
- D. Balance Quality: Conform to AMCA 204.

1.3 DAMPERS

- A. A gravity backdraft or motorized control damper is required on every exhaust fan.
- B. Fans which are noted to operate continuously or have a capacity of 300 cfm or less shall have a gravity backdraft damper unless noted otherwise. All other fans shall have a motorized control damper.
- C. See 23 33 00 for motorized control dampers.
- D. Provide insulated control dampers where scheduled or where required by 23 33 00.

PART 2 PRODUCTS

2.1 UP-BLAST CENTRIFUGAL TYPE I EXHAUST FANS

- A. Manufacturers: Greenheck, CaptiveAire, or approved equal. UL 762 Listed.
- B. Construction: Spun aluminum with rigid internal support and welded construction. Backward inclined aluminum wheel and inlet, statically and dynamically balanced. Motor cooling tube and heat baffle insulation.
- C. Belt Drive:
 - 1. Motor: Premium efficiency, heavy duty ball bearing type with steel frame mounted on vibration isolators out of the air stream. Selected operating horsepower to be a maximum of 80% of rated motor horsepower without using safety factor.
 - 2. Bearings: Pillow block type, self-aligning, permanently sealed, lubricated ball bearings, with L-10 life at 100,000 hours.
 - 3. Shafts: Hot rolled steel, ground and polished, with key way.
 - 4. V-Belt Drive: Cast iron or steel sheaves, dynamically balanced, keyed. Variable and adjustable pitch sheaves selected so required rpm is obtained with sheaves set at mid-position. Matched belts, and drive rated minimum 1.5 times nameplate rating of motor.

- D. Direct Drive:
 - 1. Motor: Electronic Commutation DC brushless motor with internal solid state AC/DC converter circuitry and heavy duty ball bearings. Speed controllable down to 20% of full speed. Minimum 85% efficient at all speeds.
 - a. Motor mounted potentiometer speed control dial.
 - b. [or] 0-10 volt control signal speed input.
- E. Accessories:
 - 1. Insulated roof curb with liner; matched to roof slope.
 - 2. Vented curb extension.
 - 3. Heat baffle
 - 4. High temp curb seal.
 - 5. NEMA disconnect switch.
 - 6. Hinged curb kit with cables.
 - 7. Teflon non-stick wheel coating.
 - 8. Clean out port on windband.
 - 9. Grease trap with drain and absorbent material.

PART 3 EXECUTION

3.1 INSTALLATION

- A. Secure roof fans with cadmium plated steel lag screws to roof curb.
- B. Suspended Fans: Install flexible connections between inlet and outlet of fan and ductwork. Ensure metal bands of connectors are parallel with minimum one inch flex between ductwork and fan while running.
- C. Install safety screen where inlet or outlet is exposed.
- D. Install gravity backdraft or motorized control dampers on discharge of exhaust fans and as indicated on Drawings.
- E. Provide sheaves required for final air balance.

3.2 MANUFACTURER'S FIELD SERVICES

- A. Furnish services of factory trained representative for minimum of one day to start-up, calibrate controls, and instruct Owner on operation and maintenance.

3.3 CLEANING

- A. Vacuum clean inside of fan cabinet.

3.4 DEMONSTRATION

- A. Demonstrate fan operation and maintenance procedures.

3.5 PROTECTION OF FINISHED WORK

- A. Do not operate fans for until ductwork is clean, filters in place, bearings lubricated, and fan has been test run under observation.

END OF SECTION

SECTION 23 38 00 - HOODS

PART 1 **GENERAL**

1.1 SUMMARY

- A. Section Includes:
 - 1. Type I Grease Hood

1.2 REQUIREMENTS

- A. The equipment of this section shall be provided by a single vendor.

PART 2 **PRODUCTS**

2.1 TYPE I GREASE HOOD

- A. Manufacturers: Greenheck, CaptiveAire, or approved equal.
- B. Kitchen Ventilation hood shall be Type I, wall canopy type. The hood shall be UL 710 Listed without fire damper for 400°F rated cooking appliances.
- C. The hood exterior shall be constructed of a minimum of 18 gauge stainless steel with an embossed finish 430 SS. The hood(s) shall be constructed using the standing seam method for optimum strength. An integral 3 inch air space is provided to meet NFPA 96 clearance requirements against limited combustible walls. All seams, joints and penetrations of the hood enclosure shall be welded and/or liquid tight. All unexposed interior surfaces shall be constructed of a minimum 18 gauge corrosion resistant steel including, but not limited to ducts, plenum, and brackets.
- D. The hood shall include a filter housing constructed of the same material as the hood. The Grease-X-Tractor high efficiency stainless filters shall be UL 1046 Classified and NSF Certified. Filters shall direct the exhaust airflow through individual cyclone chambers, utilizing centrifugal impingement grease extraction technology. The filter housing shall terminate in a pitched, full length grease trough which shall drain into a removable grease container.
- E. The hood shall include a Performance Enhancing Lip (PEL) to improve capture efficiency by turning air back into the hood.
- F. Vapor proof, U. L. Listed incandescent or LED light fixtures shall be pre-wired to a junction box situated at the top of the hood for field connection. Provide quantity of lights necessary to obtain 40 foot-candles on working surface.
- G. Hood shall be built in accordance with National Fire Protection Association (NFPA) Bulletin #96, International Mechanical Code (IMC), and bear the National Sanitation Foundation (NSF) Seal of Approval.
- H. External Supply Plenums: Air Curtain Supply Plenum (ASP) with perforated panels for low velocity air distribution. Full length of hood, 12 to 24 inch width.
 - 1. Internally insulated supply plenum.

2.2 FIRE SUPPRESSION SYSTEM

- A. Manufacturers: Ansul, Amerex or approved equal.
- B. Factory engineered, pre-piped, wet chemical, UL 300 fire suppression system complete with gas valve, detectors, fusible links, release mechanism, tank, fire suppression agent, remote manual pull station, relays and remote mounted fire cabinet.
- C. Schedule 40 black iron pipe. Factory installed piping concealed above hood. Exposed appliance drops shall be chrome. Field piping from hood to remote chemical tank cabinet.
- D. Electric gas solenoid valve with manual reset relay.

2.3 CONTROL

- A. Provide by hood manufacturer.
- B. Temperature Interlock with heat sensor.

PART 3 EXECUTION

3.1 INSTALLATION

- A. Install in accordance with NFPA 96.
- B. Ensure that hood operation is interlocked with cooking appliances by use of heat sensor or gas valve interlock.
- C. Provide 100W equivalent LED bulbs for incandescent fixtures.
- D. Fire suppression system shall be installed by factory certified distributor and include mounting cabinet, connection of detection lines, connection of supply lines, mounting and connection of remote manual pull station and control connection of gas valve. System shall be charged and tagged.

3.2 TESTING

- A. Review exhaust and make-up air test and balance for compliance with scheduled equipment, UL tested minimum airflows and code minimum air flows.
- B. Perform smoke capture and containment test with appliances installed under hood per IMC 507.6.1. Test shall simulate cooking by producing smoke or steam. Provide written report of visual observations.

END OF SECTION

SECTION 23 74 23 - OUTDOOR MAKEUP AIR-HANDLING UNITS

PART 1 **GENERAL**

1.1 SUMMARY

- A. Section includes:
 - 1. Makeup air handling units

1.2 QUALITY ASSURANCE

- A. Outside Air Damper Leakage: Test in accordance with AMCA 500.

1.3 ELECTRICAL

- A. Short-Circuit Current Rating (SCCR): All HVAC and refrigeration equipment with multi-motor or combination electrical loads shall comply with NEC 440.4(B) and must include a SCCR greater than the Available Interrupting Current (AIC) of the electrical circuit serving the equipment. See electrical drawings for AIC kA rating. For equipment 60 Amps or less MOCP the SCCR may be presented in writing from the manufacturer or shown on the unit nameplate. Equipment over 60 Amps MOCP must list the SCCR on the unit nameplate. If AIC rating is unavailable or cannot be determined provide a minimum SCCR of 10kA.

PART 2 **PRODUCTS**

2.1 MAKEUP AIR HANDLING UNITS

- A. Manufacturers: Greenheck, CaptiveAire, or approved equal.
- B. General: Packaged makeup air unit consisting of insulated cabinet, fan, furnace, filters, motor, controls and accessories as indicated below. All components by the same manufacturer with AMCA rating and UL approved.
- C. Fans: Centrifugal fan double width, double inlet, statically and dynamically balanced. Mounted on a common base with motor; spring isolated. Steel fan shafts shall be mounted in permanently lubricated ball bearings with L10 life of 100,000 hours at maximum speed.
- D. Motors and Drives: Heavy duty, EPACT, permanently lubricated. Cast pulleys with machined surface. Drive shall be sized for a minimum of 150% of driven horsepower.
- E. Unit Casing: Double wall insulated with internal frame type construction of galvanized steel. Powder coated paint. All components shall be easily accessible through removable doors.
- F. Furnace: Indirect gas fired, 80% efficient with a 4:1 turn down ratio, stainless steel heat exchanger, power venting system, gas pressure regulator, gas valve, electronic modulating controls, direct spark ignition system, high limit and a 24 volt control transformer. Insulated double wall construction.
- G. Intake: Weatherhood, galvanized steel with birdscreen, aluminum mesh filters and low leak damper with motorized actuator.

- H. Filters: 2" pleated, MERV 8 mounted in a V-bank arrangement; accessible through a removable access panel.
- I. Controls: Remote industrial control panel with HOA switches for fan and heat, indicator lights for fan, heat and dirty filter, and room override thermostat.
 - 1. Duct supply temperature control for furnace staging.
- J. Electrical: All internal electrical components shall be prewired for single point power connection. All electrical components shall be UL listed. Control center shall include motor starter, control circuit fusing, control transformer for 120 VAC circuit, integral disconnect switch with separate motor fusing and terminal strip.
- K. Accessories:
 - 1. Filter gauge with dirty filter light
 - 2. Discharge temperature control
 - 3. Freezestat
 - 4. Neoprene / Spring blower isolation
 - 5. 5 year heat exchanger warranty
 - 6. Insulated roof curb with duct adapter

PART 3 EXECUTION

3.1 EXAMINATION

- A. Verify roof curbs are installed and dimensions are as shown on shop drawings.
- B. Verify gas piping rough-in is at correct location.
- C. Verify electrical rough-in is at correct location.

3.2 PREPARATION

- A. Furnish roof curbs and vibration isolation for installation.

3.3 INSTALLATION

- A. Install in accordance with ARI 430.
- B. Roof Curb:
 - 1. Assemble roof curb.
 - 2. Install roof curb level.
 - 3. Coordinate curb installation and flashing.
 - 4. Install units on roof curb providing watertight enclosure to protect ductwork and utility services.
 - 5. Install gasket material between unit base and roof curb.
- C. Install flexible connections between unit and inlet and discharge ductwork. Install metal bands of connectors parallel with minimum 1 inch flex between ductwork and fan while running.
- D. Install assembled units with vibration isolators. Install isolated fans with resilient mountings and flexible electrical leads.
- E. Provide fixed sheaves required for final air balance.
- F. Install components furnished loose for field mounting.

- G. Install electrical devices furnished loose for field mounting.
- H. Install control wiring between unit and field installed accessories.

3.4 MANUFACTURER'S FIELD SERVICES

- A. Furnish initial start-up and shutdown during first year of operation, including routine servicing and checkout.
- B. Furnish services of factory trained representative for minimum of one day to leak test, refrigerant pressure test, evacuate, dehydrate, charge, start-up, calibrate controls, and instruct Owner on operation and maintenance.

3.5 CLEANING

- A. Vacuum clean coils and inside of unit cabinet.
- B. Install temporary filters during construction period. Replace with permanent filters at Substantial Completion.
- C. After construction is completed, including painting, clean exposed surfaces of units.
- D. Touch up marred or scratched surfaces of factory finished cabinets, using finish materials furnished by manufacturer.

3.6 DEMONSTRATION

- A. Demonstrate unit operation and maintenance.

3.7 PROTECTION OF FINISHED WORK

- A. Do not operate units until ductwork is clean, filters are in place, bearings lubricated, and fan has been test run under observation.
- B. Protect finished surfaces of cabinets with protective covers during remainder of construction.

END OF SECTION

SECTION 270000 - TELEPHONE AND DATA SYSTEM

PART 1 - GENERAL

1.1 DESCRIPTION

- A. Provide all conduits, outlet boxes and power for low voltage work. All cables, jacks, racks, terminals, cabinets and connections for telephone / data wiring system to be by Owner's Sub-Contractor.
- B. Provide plywood backing for equipment mounting as indicated on drawings and as directed by Architect.
- C. Conform to the requirements of Division 00 and 01, including the General Conditions, and Supplementary Conditions of the Contract.

PART 2 - PRODUCTS

2.1 MATERIALS

- A. Provide minimum 3/4" conduit for cables to be installed in exposed locations.
- B. Provide minimum 2-gang outlet boxes for all telephone/data jacks. Coordinate jack arrangements with Owner.
- C. For all areas, provide 1- 3/4" conduit to TTB/ITB for each telephone outlet and each data outlet as required. Contractor may run up to three outlets per homerun, increasing conduit size by 1/4" for each additional outlet. Do not exceed maximum conduit fill of 40% conduit capacity per EIT/TIA-569.
- D. Interface with Fire Alarm Panel for Central Station Monitoring by Owner's Sub-Contractor. See Section 28 33 00.

PART 3 - EXECUTION

3.1 INSTALLATION

- A. Coordinate all telephone/data conduit sizing requirements and routing with Owner.
- B. Coordinate all telephone/data outlet box sizing requirements with Owner. Outlet boxes in finished areas to be flush mounted. Outlet boxes in utility rooms or unfinished areas may be surface mounted.
- C. Install receptacles and power to equipment racks in IT Rooms as required. See drawings for locations.
- D. Verify exact locations of devices with Architect prior to installation. ~~August 25, 2023~~
- E. All telephone handsets, switching equipment, IT racks, servers and connections to be provided by Owner's Telephone/ IT system installer. Fully coordinate all installation requirements with Owner prior to installation of conduits and outlets boxes.

SECTION 33 11 16 - SITE WATER DISTRIBUTION

PART 1 GENERAL

1.1 SUMMARY

- A. Section includes pipe and fittings for water transmission line and valves.
- B. Section includes water meter setters, meter boxes, and hydrants assemblies

1.2 RELATED SECTIONS

- A. Section 32 05 16 - Aggregate Materials.
- B. Section 31 23 17 - Trenching.

1.3 REFERENCES

- A. ASTM D1557 - Standard Test Methods for Laboratory Compaction Characteristics of Soil Using Modified Effort.
- B. ASTM 2922 - Test Methods for density of soil and soil aggregate in place by nuclear methods (Shallow depth).
- C. AWWA C600 (American Water Works Association) -Installation of Ductile-Iron Water Mains and Appurtenances.
- D. AWWA C104 (American Water Works Association) -Cement mortar lining for ductile iron pipe and fittings for water.
- E. AWWA C111 (American Water Works Association) - Rubber gasket joints and grey iron pressure pipe and fittings.

1.4 SUBMITTALS

- A. Per "Submittal Procedures" Section: Submittal procedures.
- B. Product Data: Submit data on pipe materials, pipefittings, valves, meters, vaults, hydrants, backflow devices, fire department connection, post indicator valves, and accessories.

1.5 CLOSEOUT SUBMITTALS

- A. Project Record Documents: Record actual locations of piping mains, valves, connections, thrust restraints, and invert elevations.

1.6 QUALITY ASSURANCE

- A. Perform Work in accordance with WSDOT Section 7-11, 7-12, and 7-14 and West Sound Utility District's standards and requirements.

1.7 DELIVERY, STORAGE, AND HANDLING

- A. Deliver and store valves in shipping containers with labeling in place.

PART 2 PRODUCTS

2.1 WATER PIPE

- A. Ductile Iron Pipe: Materials shall meet the requirements of WSDOT Section 9-30.1 in conformance with AWWA C151 and AWWA C104 for Class 50 or 52 pipe as required.
- B. Ductile fittings: Materials of standard thickness shall meet the requirements of WSDOT Section 9-30.2 in conformance with AWWA C110 and AWWA C153.
- C. Ductile Iron Joints: Non-restrained rubber gasketed joints shall meet the requirements of WSDOT Section 9-30.1(1) in conformance with AWWA C111.
- D. Steel Pipe: materials shall meet the requirements of WSDOT Section 9-30.1(4)A and B in conformance with ASTM A120.
- E. Steel Fittings: Materials shall meet the requirements of WSDOT 9-30.2(4)B in conformance with ASTM A 47, Grade 32510 and ANSI B16.3. Threads shall meet the requirements of ANSI B2.1.
- F. Copper Tubing: Materials shall meet the requirements of WSDOT Section 9-30.6(3)A in conformance with ASTM A 120.

2.2 GATE VALVES - 3 INCHES AND OVER

- A. Gate Valves: Valves shall meet the requirements of WSDOT 9-30.3 in conformance with AWWA C500 or AWWA C509 and shall be iron body, bronze trim, non-rising stem with square nut, single wedge, resilient seat, flange or mechanical joint as indicated on the plans.

2.3 BEDDING AND COVER MATERIALS

- A. Bedding: Fill Type as specified in Section 320516 Aggregates.
- B. Cover: Fill Type, as specified in Section 320516 Aggregates.

2.4 HYDRANT

- A. Hydrant Assembly: Hydrants shall meet the requirements of WSDOT 9-30.5 in conformance with AWWA C502 and UL 246.
- B. Hydrant Extensions: Fabricate in multiples of 6 inches with rod and coupling to increase barrel length.
- C. Hose and Streamer Connection: Match sizes with applicable local fire department standards, two hose nozzles and one “Storz” pumper nozzle.
- D. Finish: Primer and two coats of enamel in color required by the local fire department standards.

2.5 ACCESSORIES

- A. Concrete for Thrust Restraints: Class 3000 or commercial class concrete, WSDOT Section 6-02.3(2) B.
- B. Domestic Service Assembly: as indicated on the plans.
- C. Tapping Sleeve: cast iron split sleeves and split tee, Clow F-1268 or equal, size as indicated on the plans.

PART 3 EXECUTION

3.1 EXAMINATION

- A. Administrative Requirements: Coordination and project conditions.
- B. Verify and coordinate connection to the existing transmission water main.

3.2 PREPARATION

- A. Cut pipe ends square, ream pipe and tube ends to full pipe diameter, remove burrs.
- B. Remove scale and dirt on inside and outside before assembly.
- C. Prepare pipe connections to equipment with flanges or unions

3.3 BEDDING

- A. Excavate pipe trench in accordance with WSDOT Section 7-10.
- B. Form and place concrete for pipe thrust restraints at change of pipe direction. Place concrete to permit full access to pipe and pipe accessories.
- C. Place bedding material at trench bottom, level fill materials in one continuous layer not exceeding 6 inches compacted depth; compact to 95 percent dry density.
- D. Backfill around sides and to top of pipe with cover, fill, tamp in place and compact to 95 percent dry density.
- E. Maintain optimum moisture content of fill material to attain required compaction density.

3.4 INSTALLATION - PIPE

- A. Maintain separation of water main from sewer piping in accordance with Washington State Department of Health requirements.
- B. Install pipe to indicated elevation to within tolerance of 5/8 inch.
- C. Install ductile iron piping and fittings to AWWA C600 and in conformance with WSDOT Sections 7-08, 7-09, 7-10, and 7-11, and 7-12 and West Sound Utility District’s standards and requirements.
- D. Route pipe in straight line.
- E. Install pipe to allow for expansion and contraction without stressing pipe or joints.

- F. Install access fittings to permit disinfection of water system.
- G. Slope water pipe and position drains at low points.
- H. Form and place concrete for thrust restraints at each elbow or change of direction of pipe main.
- I. Establish elevations of buried piping with not less than 3 feet of cover. Provide fittings as necessary to perform vertical adjustments in pipe to conform to finish grades.
- J. Install trace wire continuous over top of pipe, buried 6 inches below finish grade.
- K. Plugs and Connections for branches, stubs, or other open ends, which are not to be immediately connected, shall be made in conformance with WSDOT Section 7-08.3(2) F. Contractor is to clearly mark the ends of the pipe stubbed onto the future lots with 2 x 4's, painted white, with the black stenciled letters labeling the pipe "water". A measure down distance to the pipe invert is to be provided on the 2 x 4.

3.5 INSTALLATION – VALVES, HYDRANTS, AND VAULTS

- A. Set valves on solid bearing.
- B. Center and plumb valve box over valve. Set box cover flush with finished grade.
- C. Set hydrants plumb, locate "Storz" pumper nozzle perpendicular to and facing roadway.
- D. Set hydrants to grade with nozzles at least 20 inches above grade.
- E. Provide drainage pit 36" square by 24" deep filled with 2 inch minus washed rock. Encase elbow of hydrant in gravel to 6" above the drain opening. Do not connect drain opening to sewer.
- F. Paint hydrants in accordance with applicable Local Fire District standards.
- G. Hydrants are to be installed in conformance with WSDOT Section 7-14 and valves are to be installed in conformance with WSDOT Section 7-12.
- H. Backflow preventers shall be inspected by a certified backflow prevention specialist prior to acceptance by the Owner.

3.6 DISINFECTION AND TESTING OF DOMESTIC WATER PIPING SYSTEM

- A. The water pipes and appurtenances shall be disinfected in accordance with WSDOT Section 7-11.3(12) and the APWA Standard Specifications.
- B. The Contractor shall obtain samples and submit them to West Sound Utility District.
- C. The water main will not be accepted by the Owner until the West Sound Utility District approves of the samples.
- D. Upon completion of installing the water main pipe, valves, and appurtenances, the Contractor shall test the system. It is the Contractor's responsibility to insure the adequacy of the system. Pipelines shall be filled at a rate of 1 cubic foot per second (450 gallons per minute) or less. The Contractor shall allow 15 minutes from having the pipe full in order to purge it of air.
- E. Contractor shall perform hydrostatic pressure testing per WSDOT Standard Specification Section 7-09.3(23).

3.7 FIELD QUALITY CONTROL

- A. Compaction Testing: In accordance with ASTM D1557.
- B. When tests indicate Work does not meet specified requirements, remove Work, replace and retest.

END OF SECTION

SECTION 33 31 00 - SANITARY SEWAGE SYSTEMS

PART 1 GENERAL

1.1 SELECTION INCLUDES

- A. Sanitary sewage piping, manholes, fittings, accessories, and bedding.
- B. HDPE sanitary sewer force main.
- C. Duplex Lift Station in H-20 rated Basin

1.2 RELATED SECTIONS

- A. Section 32 05 16 - Aggregate: Aggregate for backfill in trenches.
- B. Section 31 23 16 - Excavation: Product and execution requirements for excavation and backfill required by this section.
- C. Section 31 23 17 - Trenching: Execution requirements for trenching required by this section.
- D. Section 31 23 23 - Fill: Requirements for backfill to be placed by this section.

1.3 REFERENCES

- A. ASTM A746 - Standard Specification for Ductile Iron Gravity Sewer Pipe.
- B. ASTM D1557 - Standard Test Methods for Laboratory Compaction Characteristics of Soil Using Modified Effort.
- C. ASTM D2922 - Standard Test Method for Density of Soil and Soil-Aggregate in Place by Nuclear Methods (Shallow Depth).
- D. ASTM D3034 - Standard Specification for Type PSM Poly (Vinyl Chloride) (PVC) Sewer Pipe and Fittings.
- E. ASTM D3350 – HDPE Pipe

1.4 SUBMITTALS

- A. Product Data: Submit data indicating pipe material used, pipe accessories, and fittings.
- B. Manufacturer's Installation Instructions: Indicate special procedures required to install Products specified.

1.5 CLOSEOUT SUBMITTALS

- A. Project Record Documents: Record location of pipe runs, connections, manholes, cleanouts, and invert elevations.

1.6 QUALITY ASSURANCE

- A. Perform Work in accordance with WSDOT 7-08 and 7-17 and West Sound Utility District and Heath Department Standards.

1.7 COORDINATION

- A. Coordinate the Work with termination of sanitary sewer connection outside building.

PART 2 PRODUCTS

2.1 SANITARY SEWAGE PIPE

- A. Ductile Iron Pipe: ASTM A746, AWWA C151, Gravity Sewer Pipe Class 50, conforming to WSDOT 9-05.13. Inside nominal diameter and outside drop connection fabrication as indicated on the plans.
- B. Plastic Pipe: ANSI/ASTM D3034, SDR 35 Tpe PSM Poly Vinyl Chloride (PVC) material conforming to WSDOT 9-05.12. Inside nominal diameter as indicated on the plans, bell and spigot style solvent sealed joint end.
- C. HDPE Sanitary sewer force main pipe: WSDOT 9-05.2, SDR 17.
- D. Fittings:
 - 1. Ductile iron fittings – materials of standard thickness shall meet the requirements of WSDOT 9-30.2 in conformance with AWWA C110 or C153.

2. PVC Fittings: Same material as pipe, shall be injection molded, factory welded, or factory solvent cemented to suit pipe size and end design, in required tee, bends, elbows, cleanouts, reducers, traps and other configurations required.

E. Accessories:

1. Ductile Iron Joints. Material shall meet the requirements of WSDOT 9-05.13 in conformance with AWA C-111 using rubber gasketed joints.
2. PVC Joints. Material shall meet the requirements of WSDOT 9-05.12 in conformance with ASTM D3212 using restrained gasket conforming to ASTM F477.
3. Trace Wire: Magnetic detectable conductor with brightly colored plastic covering.

2.2 MANHOLES

- A. Manholes: in conformance with WSDOT Section 7-05.

2.3 BEDDING AND COVER MATERIALS

- A. Bedding as specified in Section 32 05 16.

2.4 CLEANOUTS

- A. Cleanouts: in conformance with WSDOT Section 7-19.

2.5 DUPLEX LIFT STATION

- A. Lift Station fittings, pump, system, switches, and control panel to be Weil provided by Columbia Hydronics Company (Gary Fox 206-431-7692) or equal. Pump to be a Weil Model 2516C-2 sized for 50 GPM at 88' TDH with 5HP/3450/208-230/60/3 explosion proof motors or equal.
- B. Installation provided by contractor per manufacturer's recommendations.
- C. Basin to be provided by contractor, and must be H-20 rated sized for Duplex pumps, with capacity per plumber requirements.

PART 3 EXECUTION

3.1 EXAMINATION

- A. Verification of existing conditions before starting work. Verify trench cut and excavation base is ready to receive work and excavations, dimensions, and elevations are as indicated on drawings.

3.2 PREPARATION

- A. Correct over excavation with coarse aggregate or lean concrete.
- B. Remove large stones or other hard matter which could damage pipe or impede consistent backfilling or compaction.

3.3 BEDDING

- A. Excavate pipe trench in accordance with Section 31 23 17 and WSDOT Section 2-09 and 7-08.3(1) C.
- B. Place bedding material at trench bottom, in accordance with WSDOT Section 7-08.3(1) C. Level materials in continuous layer not exceeding 8 inches, compact to 95 percent. Maintain optimum moisture content of bedding material to attain required compaction density.

3.4 INSTALLATION - PIPE

- A. Install pipe, fittings, and accessories in accordance with WSDOT Section 7-08 and 7-17. Seal joints watertight.
- B. Lay pipe to slope gradients noted on drawings; with maximum variation from indicated slope of 1/8 inch in 10 feet.
- C. Install bedding at sides and over top of pipe to minimum compacted thickness of 12 inches, compact to 95 percent.
- D. Refer to Section 31 23 23 for Backfilling and Section 31 23 17 for Trenching requirements. Do not displace or damage pipe when compacting.

- E. Connect to municipal sewer system at locations shown on the plans.
- F. Install trace wire continuous over top of pipe, buried 6 inches below finish grade, above pipeline.
- G. Install Work in accordance with WSDOT Section 7-08 and 7-17 and West Sound Utility District and Heath Department Standards.
- H. Plugs and connections for pipe branches, stubs, and other open ends which are not to be immediately connected shall be performed per WSDOT Section 7-08.3(2) F. Contractor is to clearly mark the ends of the pipe stubbed onto the future lots with 2 x 4's, painted white, with the black stenciled letters labeling the pipe "SEWER". A measure down distance to the pipe invert is to be provided on the 2 x 4.
- I. At locations where existing sanitary sewer pipes and mains are to cut and abandoned, plugging of the existing pipe shall be accomplished in conformance with WSDOT Section 7-08.3(4).

3.5 INSTALLATION – MANHOLES

- A. Excavate for manholes in accordance with Section 31 23 16 and WSDOT Section 2-09.3(4).
- B. Form bottom of excavation clean and smooth to correct elevation.
- C. Form and place cast-in-place concrete base pad, with provision for sanitary sewer pipe end sections.
- D. Establish elevations and pipe inverts for inlets and outlets as indicated on Drawings.
- E. Mount lid and frame level in grout, secured to top cone section to elevation indicated. All joints within the manholes are to be filled and sealed with grout.
- I. Install Work in accordance with WSDOT 7-05 and West Sound Utility District Sanitary Sewer standards.

3.6 FIELD QUALITY CONTROL

- A. Submittals per "Quality Requirements" Section: Field inspecting, testing, adjusting, and balancing.
- B. Request inspection prior to and immediately after placement of bedding material.
- C. Perform test on site sanitary sewage system in accordance with WSDOT Section 7-17.3(2).
- D. Compaction Testing: In accordance with ASTM D1557 and ASTM D 2922.
- E. When tests indicate Work does not meet specified requirements, remove work, replace and retest at no additional cost to the Owner.
- F. Cleaning of sanitary sewer main is to be accomplished per WSDOT Section 7-17.3(2)

3.7 PROTECTION OF FINISHED WORK

- A. Protecting finished Work from damage. Protect pipe and aggregate cover from damage or displacement until backfilling operation is in progress. Contractor is to repair and/or replace work that has been damaged prior to owner's acceptance.

END OF SECTION



11.29.2023

PACIFIC BUILDING CONVERSION
KITSAP COUNTY HUMAN SERVICES DEPARTMENT
SITE DEVELOPMENT ACTIVITY PERMIT
4459 SE MILE HILL DRIVE, PORT ORCHARD, WA 98366
Portion of the Southeast Quarter of Section 30,
Township 24 North, Range 2 East, W.M. in Kitsap County, Washington

PROJECT #	22-12139
BID SET	
ISSUE DATE	OCTOBER 23, 2023
REVISION SCHEDULE	
A	ACUP RESPONSE #1 2/17/2023
B	22-05147 RESPONSE #1 7/27/2023
C	23-05147 RESPONSE #2 9/15/2023
Δ	ADDENDUM #2 11/29/2023

SITE PLAN

SHEET #

C3.00

NOTE

THE APPROXIMATE LOCATION OF EXISTING UNDERGROUND UTILITIES ARE SHOWN ON THE PLANS. IT IS THE CONTRACTOR'S RESPONSIBILITY TO DETERMINE THE LOCATION OF EXISTING UTILITIES PRIOR TO COMMENCING WORK. THE CONTRACTOR SHALL BE RESPONSIBLE FOR DAMAGES THAT MIGHT BE OCCASIONED BY THE CONTRACTOR'S FAILURE TO LOCATE, PRESERVE AND PROTECT UNDERGROUND UTILITIES.

CALL 48 HOURS BEFORE YOU DIG
811

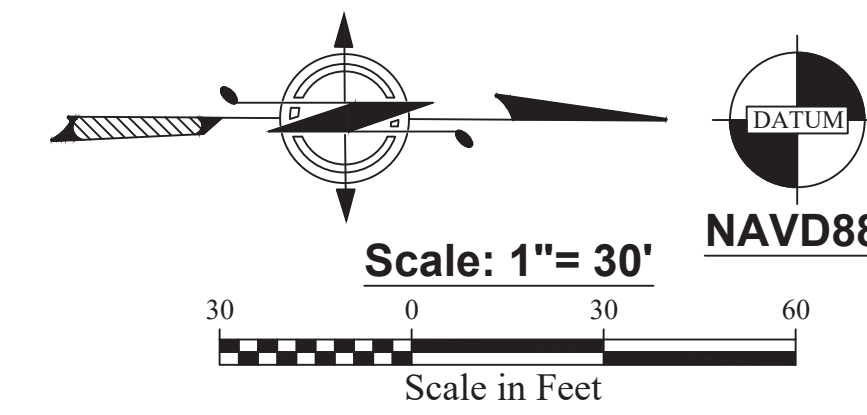

CURB RAMP NOTES:
1.50% OR FLATTER CROSS SLOPE RECOMMENDED FOR DESIGN/FORMWORK (2.00% MAX.)
7.50% OR FLATTER RECOMMENDED FRO DESIGN/FORMWORK (8.33% MAX.)
THE CURB RAMP LENGTH IS NOT REQUIRED TO EXCEED 15'. WHEN APPLYING THE 15' MAX. LENGTH THE RUNNING SLOPE OF THE CURB RAMP IS ALLOWED TO EXCEED 8.33%.
--- ADA ROUTE TO BUILDING OR SIDEWALK AT SE MILE HILL DR
SEE DETAILS ON SHEET C3.21
ANY REQUIRED SIDEWALK SHALL BE CONSTRUCTED PRIOR TO ROADWAY PAVING.

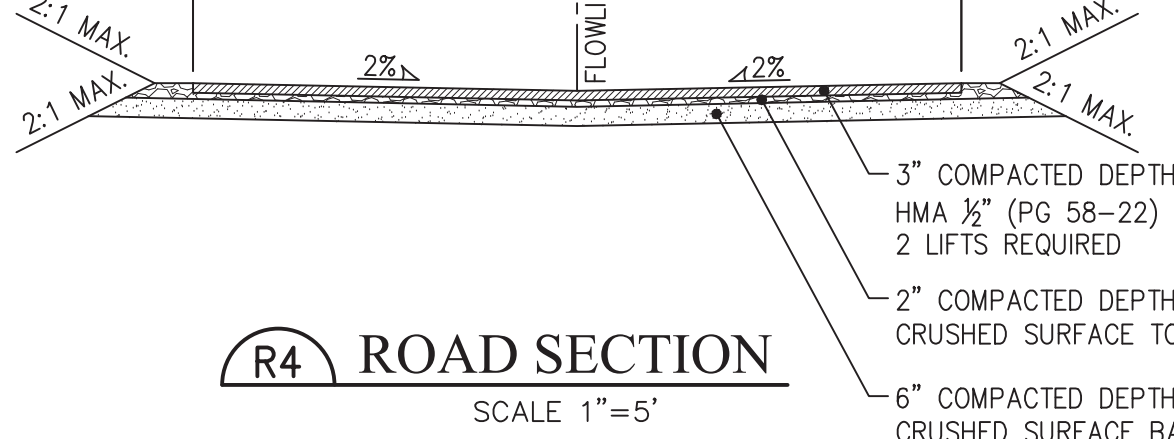
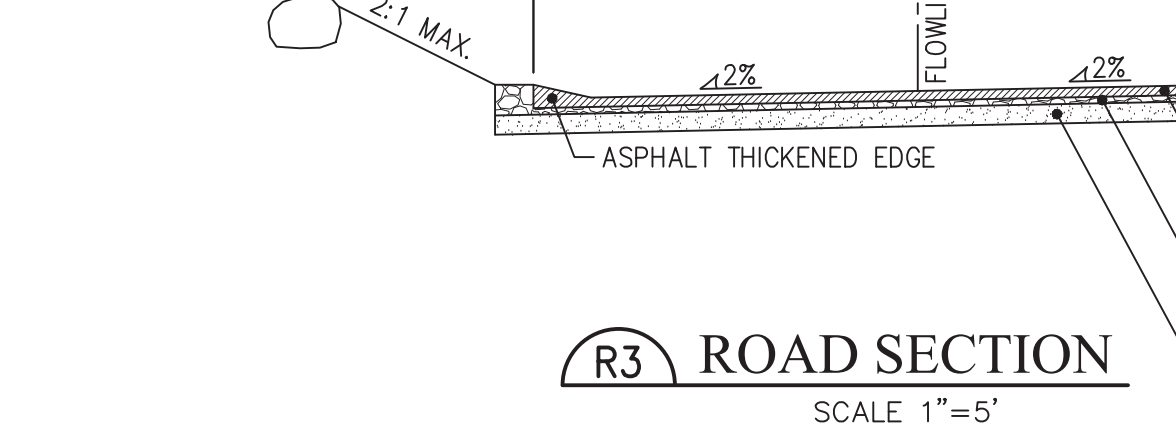
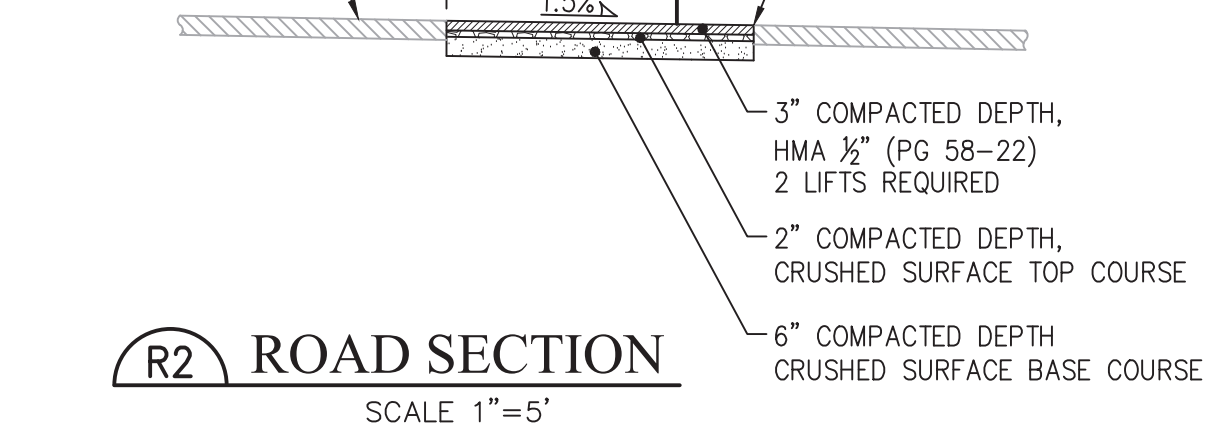
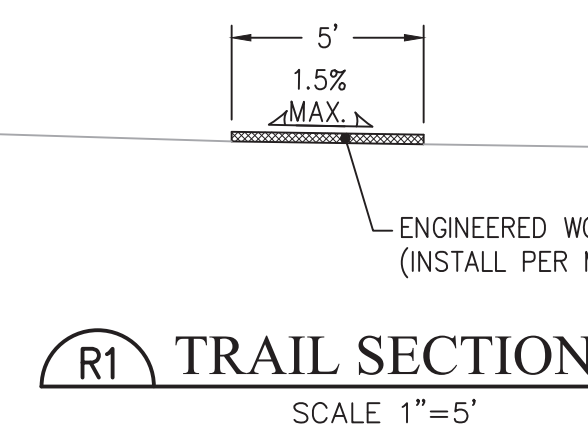
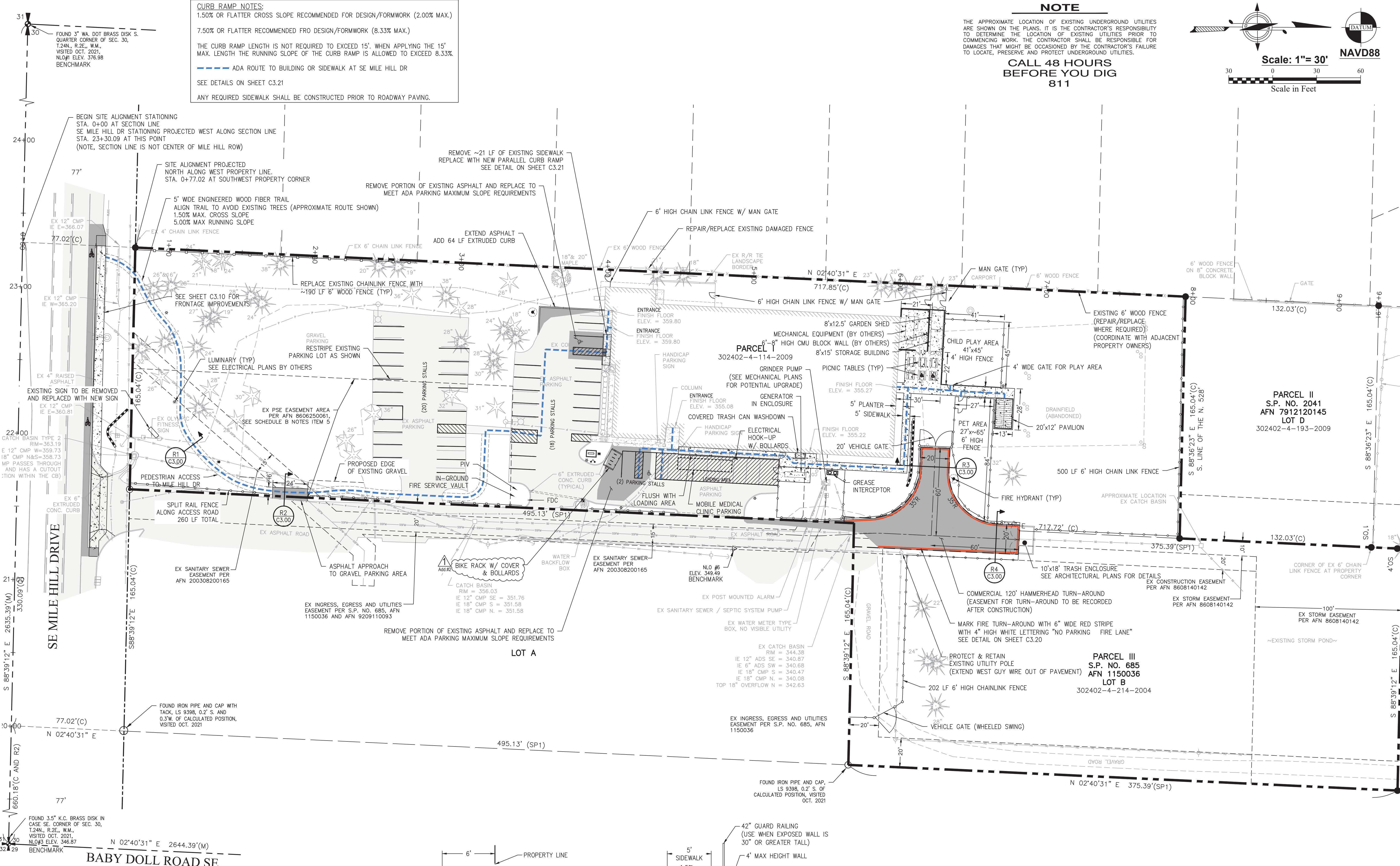

I:\SERVER\HOST\TabCAD\Projects\21239 RFM\11292023 8:50:59 AM DWG TO PDF PLOT

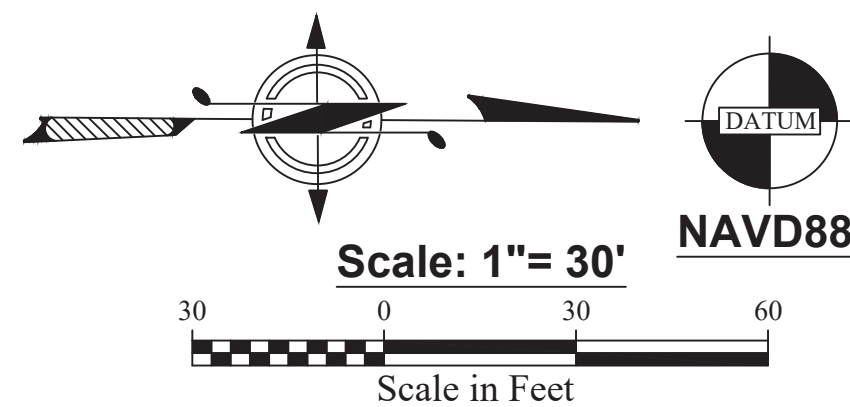

CURB RAMP & ADA PARKING STALL NOTES:
 1.50% OR FLATTER CROSS SLOPE RECOMMENDED FOR DESIGN/FORMWORK (2.00% MAX.)
 7.50% OR FLATTER RECOMMENDED FRO DESIGN/FORMWORK (8.33% MAX.)
 THE CURB RAMP LENGTH IS NOT REQUIRED TO EXCEED 15'. WHEN APPLYING THE 15' MAX. LENGTH THE RUNNING SLOPE OF THE CURB RAMP IS ALLOWED TO EXCEED 8.33%.
 FOR ADA STALLS 1.50% OR FLATTER CROSS SLOPE RECOMMENDED FOR FOR STALL AND ACCESS ROUTE. (2.00% MAX.)
 SEE DETAILS ON SHEET C3.21

WALL NOTES:
 TW = TOP OF WALL
 BEW = BOTTOM OF EXPOSED WALL (DOES NOT INCLUDE FOOTING OR REQUIRED EMBEDDED BLOCKS)
 NOTE: ALL WALLS OVER 4' IN HEIGHT OR SUSTAINING A SURCHARGE WILL REQUIRE A SEPARATE BUILDING PERMIT WITH AN ENGINEER DESIGN (NOT INCLUDED WITH THIS PLAN SET).

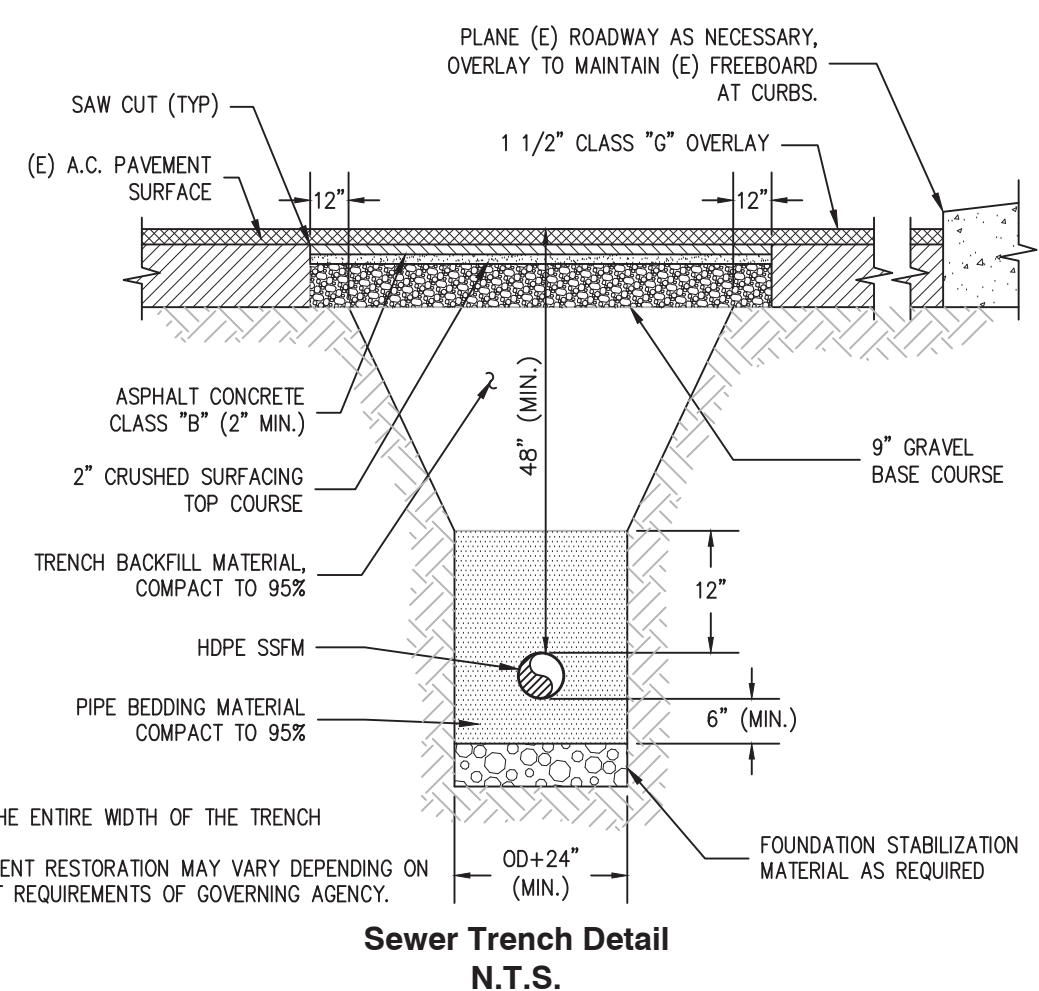
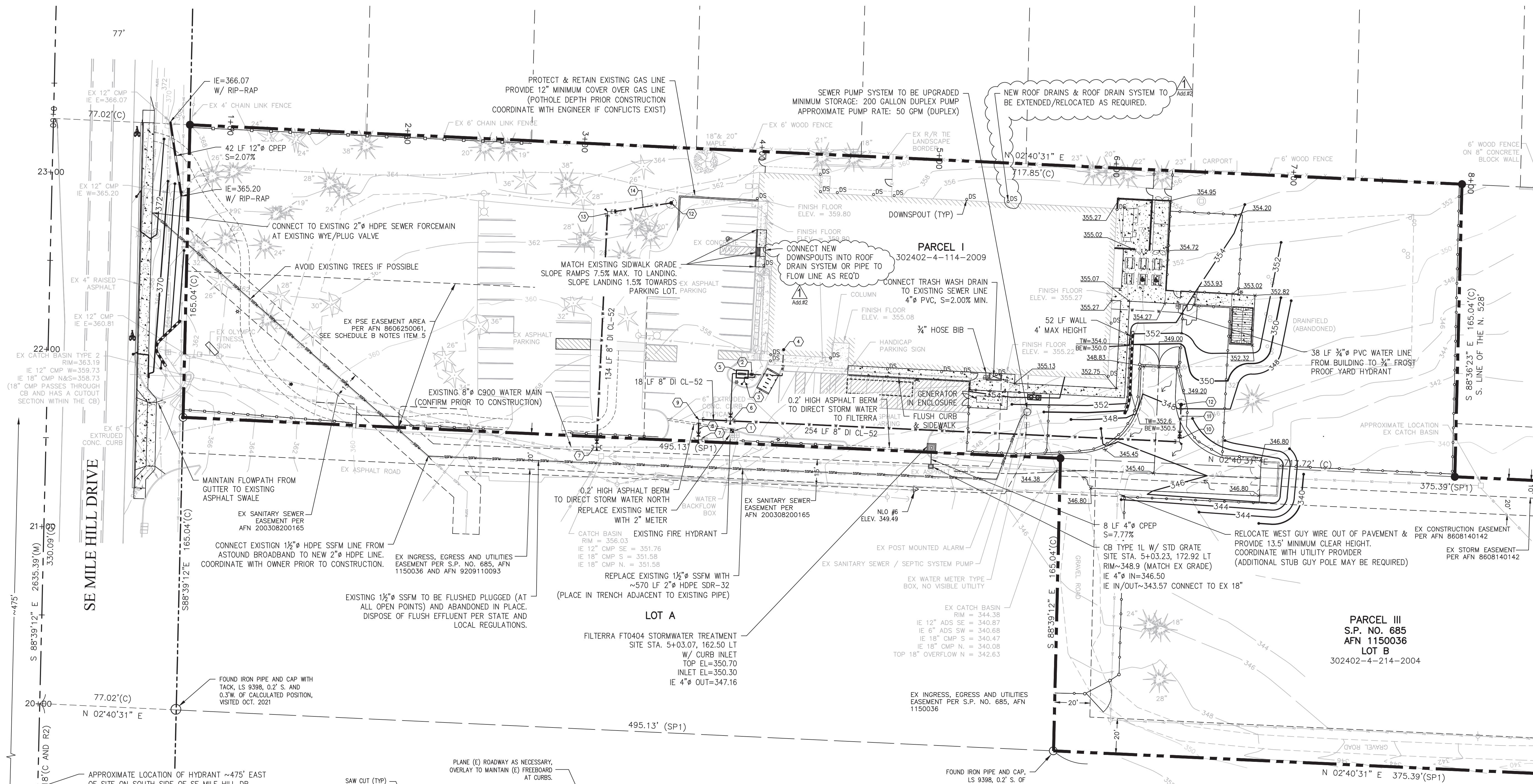

- 1) REMOVE EXISTING WATER METER AND INSTALL 2" WATER METER & SERVICE TO BUILDING. CONFIRM SERVICE SIZE & METER TO BE WITH MECHANICAL DESIGNER AND CONTRACTOR.
- 2) POST INDICATOR VALVE (PIV).
- 3) FIRE DEPARTMENT CONNECTION (FDC). SEE FIRE SPRINKLER PLANS FOR SIZING & DETAILS. CONTRACTOR TO VERIFY LOCATION PRIOR TO CONSTRUCTION.
- 4) FIRE RISER ROOM PER ARCHITECTURAL & FIRE SPRINKLER PLANS. LOCATION MAY VARY FROM THIS PLAN. CONTRACTOR TO VERIFY SIZING & LOCATIONS WITH FIRE DISTRICT PRIOR TO CONSTRUCTION.
- 5) 7'x4'-8" FIRE SERVICE VAULT WITH DETECTOR DOUBLE CHECK VALVE ASSEMBLY ON INLET WATER CONNECTION & SWING TYPE GRAVITY OPERATED CHECK VALVE FOR FDC CONNECTION. SEE DETAIL ON SHEET C5.20.
- 6) FIRE SERVICE CONNECTION 8"x8"x4" TEE (MxMxJFL) W/ THRUST BLOCK & MEGALUGS 4" GV (FLxMJ)
- 7) 8" TEE (MxMxJFL) W/ THRUST BLOCK & MEGALUGS 8" GV (FLxMJ)
- 8) 12 LF 8" DI CL-52
- 9) 8" 90° BEND (MJ) W/ THRUST BLOCK & MEGALUGS
- 10) 8" 90° BEND (MJ) W/ THRUST BLOCK & MEGALUGS 8" TO 6" REDUCER
- 11) 20 LF 6" DI CL-52
- 12) HYDRANT ASSEMBLY
- 13) 8" 90° BEND (MJ) 8" 11.25' BEND (MJ) W/ THRUST BLOCK & MEGALUGS 8" TO 6" REDUCER
- 13) 36 LF 6" DI CL-52

NOTE
 THE APPROXIMATE LOCATION OF EXISTING UNDERGROUND UTILITIES ARE SHOWN ON THE PLANS. IT IS THE CONTRACTOR'S RESPONSIBILITY TO DETERMINE THE LOCATION OF EXISTING UTILITIES PRIOR TO COMMENCING WORK. THE CONTRACTOR SHALL BE RESPONSIBLE FOR DAMAGES THAT MIGHT BE OCCURRED BY THE CONTRACTOR'S FAILURE TO LOCATE, PRESERVE AND PROTECT UNDERGROUND UTILITIES.
CALL 48 HOURS BEFORE YOU DIG 811



PACIFIC BUILDING CONVERSION
KITSAP COUNTY HUMAN SERVICES DEPARTMENT
SITE DEVELOPMENT ACTIVITY PERMIT
 4459 SE MILE HILL DRIVE, PORT ORCHARD, WA 98366
 Portion of the Southeast Quarter of Section 30,
 Township 24 North, Range 2 East, W.M. in Kitsap County, Washington

PROJECT # 22-12139

BID SET

ISSUE DATE OCTOBER 23, 2023

REVISION SCHEDULE	
A	ACUP RESPONSE #1 2/17/2023
B	22-05147 RESPONSE #1 7/27/2023
C	23-05147 RESPONSE #2 9/15/2023
Δ	ADDENDUM #2 11/29/2023

STORM, GRADING & UTILITY PLAN

SHEET #

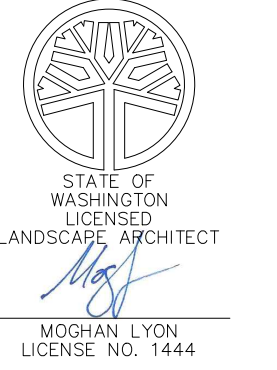
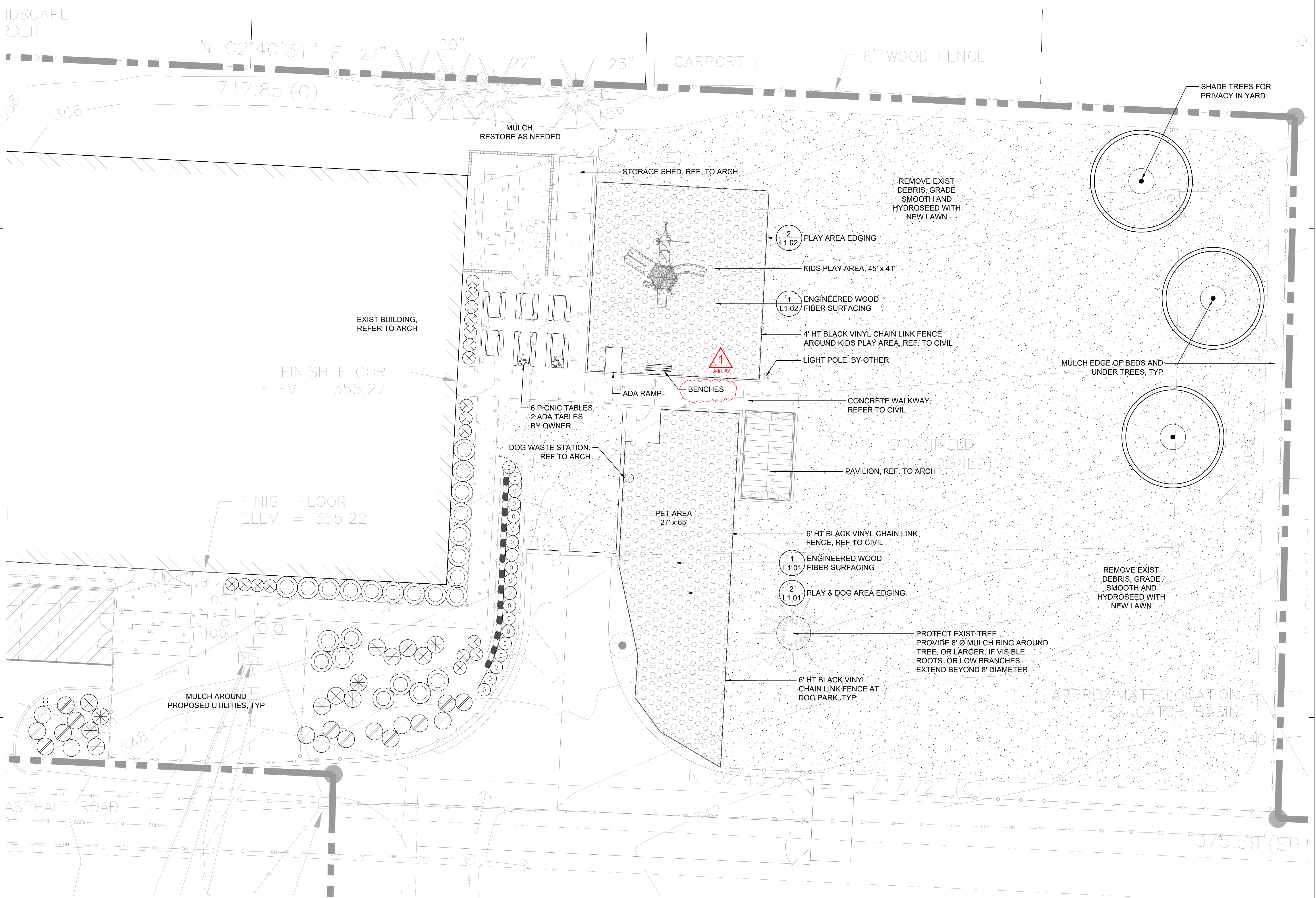

PACIFIC BUILDING CONVERSION
 KITSAP COUNTY HUMAN SERVICES DEPARTMENT
 4459 SE MILE HILL DRIVE
 PORT ORCHARD, WA 98366

PROJECT # 2021056.01

BID SET

ISSUE DATE OCTOBER 23, 2023

REVISION SCHEDULE		
1	ADDENDUM #2	11/29/2023

AHJ APPROVAL STAMP

ENLARGED SITE PLAN

SHEET #

L1.01

DATE/TIME PRINTED: 7/7/2022 10:34:30 AM
 BIM: 360/Mile Hill Temporary Housing Facility/2021056.01 Mile Hill Temporary Housing Facility - 2021.rvt

1 ENLARGED SITE PLAN
 1" = 10'-0"

PACIFIC BUILDING CONVERSION KITSAP COUNTY HUMAN SERVICES DEPARTMENT

BID SET



PROJECT INFORMATION

PROJECT DESCRIPTION

EXISTING (1) ONE STORY, 18,870 SF FITNESS CENTER TO BE RENOVATED TO A NEW CONGREGATE CARE FACILITY FOR UNHOUSED ADULTS AND FAMILIES. NEW WALLS, DOORS, SHOWER/TOILET FACILITIES, WARMING KITCHEN AND SUPPORT ADMIN SPACES INSIDE THE BUILDING. NO INCREASE IN FLOOR AREA. MINOR CHANGES TO EXTERIOR INCLUDING NEW DOORS AND CANOPIES AND REPAIRS TO EXISTING SIDING SYSTEMS. NEW HARDSCAPE AND PARKING LOT RECONFIGURATION.

SITE ADDRESS

4459 SE MILE HILL DRIVE
PORT ORCHARD, WA 98366

SITE ZONING

COMMERCIAL (10-30 DU / Ac)

LEGAL DESCRIPTION

THE WEST HALF OF THE WEST 330FT OF THE EAST 990FT OF THE SOUTHEAST QUARTER OF THE SOUTHEAST QUARTER, SECTION 30, TOWNSHIP 24 NORTH, RANGE 2 EAST, W.M., IN KITSAP COUNTY, WASHINGTON; EXCEPT THE SOUTH 77 FEET THEREOF; EXCEPT THE NORTH 528 FEET THEREOF; AND EXCEPT STATE HIGHWAY; TOGETHER WITH AN EASEMENT FOR INGRESS AND EGRESS AS DISCLOSED BY INSTRUMENT RECORDED UNDER AUDITOR'S FILE NO. 9209110093

PARCEL NUMBER(S)

302402-4-144-2009

SEC-TWN-RNG-QTR

SEC 30, TWP 24, RNG 2E (SE/4)

SITE AREA

2.75 ACRES (APPROX. 119790 SQ. FT.)

AUTHORITY HAVING JURISDICTION

KITSAP COUNTY DEPARTMENT OF COMMUNITY DEVELOPMENT
619 DIVISION STREET
PORT ORCHARD, WA 98366
(360) 337-5777

RELATED PERMITS

ACUP 22-03886
SDAP 22-05147

VICINITY MAP

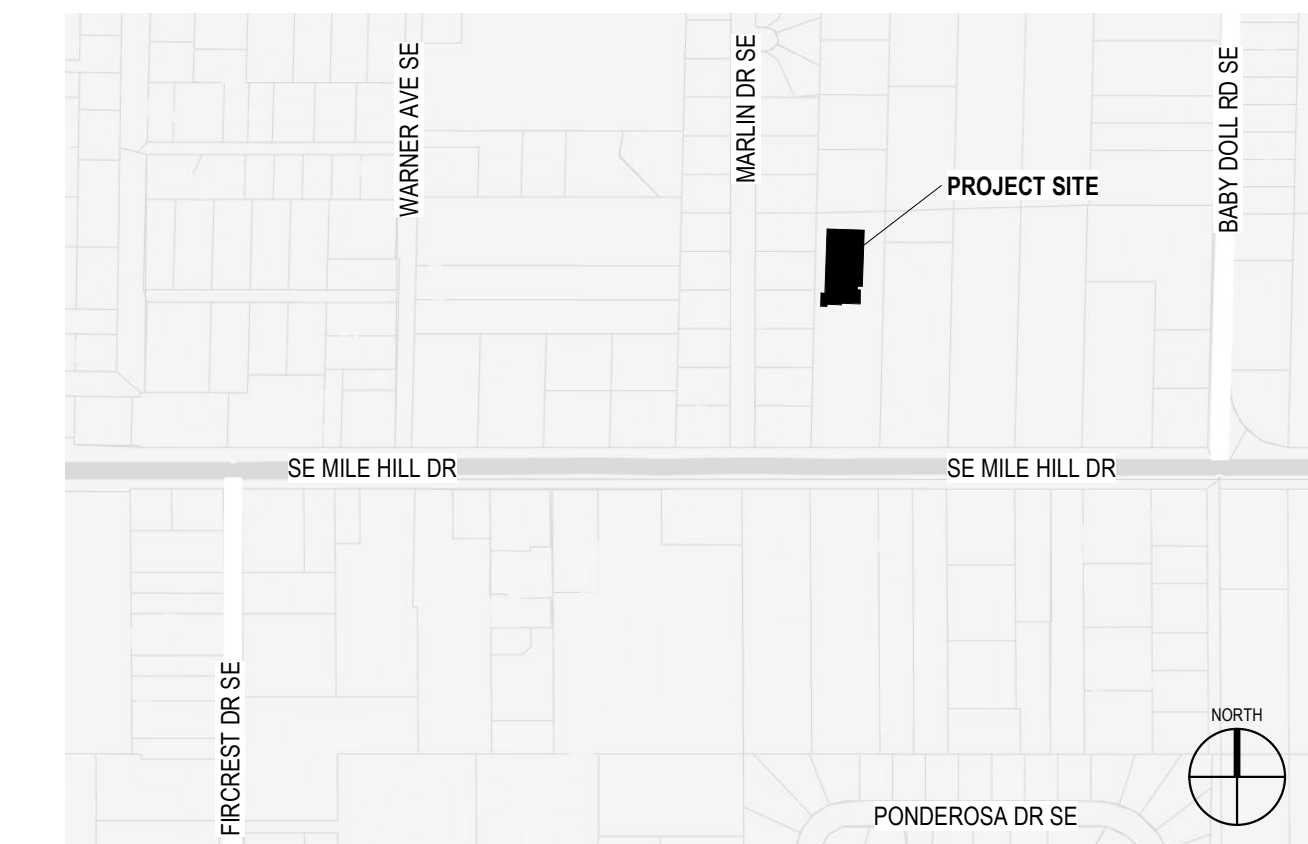

PROJECT DESIGN TEAM

OWNER

KITSAP COUNTY DEPARTMENT OF HUMAN SERVICES
345 6TH STREET, SUITE 400
BREMERTON, WA 98337

DOUG WASHBURN, DIRECTOR
(360) 337-4525
DWASHBURN@KITSAP.GOV

JUDY RAE KARLSEN, PROJECT COORDINATOR
(360) 728-6444
JRKARLSEN@KITSAP.GOV

ARCHITECT

RICE FERGUS MILLER
275 5TH ST, SUITE 100
BREMERTON, WA 98337

GREG BELDING, PRINCIPAL IN CHARGE

INKY HALEY, PROJECT MANAGER
(360) 362-1450
IHALEY@RFMARCH.COM

KIMBERLYN CAOAGAS, PROJECT DESIGNER
(360) 362-1442
KCAOAGAS@RFMARCH.COM

FOOD SERVICE

CLEVENGER ASSOCIATES
2520 COLBY AVE, SUITE 105
EVERETT, WA 98201

DOUG HINDS
(425) 331-1850
DOUG@CLEVENGERASSOC.COM

CIVIL ENGINEER

N. L. OLSON AND ASSOCIATES, INC
2453 BETHEL AVE
PORT ORCHARD, WA 98366

RON JOHNSON
(360) 876-2284
RJOHNSON@NLOLSON.COM

LANDSCAPE ARCHITECT

LYON LANDSCAPE ARCHITECTS
2111 SOUTH C STREET
TACOMA, WA 98402

MOGHAN LYON
(253) 209-4053
MOGHAN@LYONLA.COM

STRUCTURAL ENGINEER

WSW ENGINEERING

BILL WILLIAMS
(206) 402-2906
WILLIAMS@WSWENG.COM

MEPE ENGINEER

SIDER + BYERS
192 WICKERSON ST, SUITE 300
SEATTLE, WA 98109

JONATHAN HALL
(206) 530-1377
JONATHAN@SIDERBYERS.COM

RICE FERGUS MILLER

ARCHITECTURE INTERIORS PLANNING VIZLAB

275 FIFTH STREET, SUITE 100

BREMERTON, WA 98337

360-377-8773

RFMARCH.COM

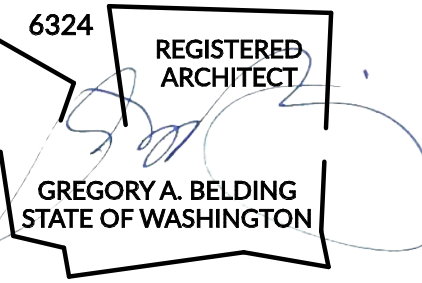

PACIFIC BUILDING CONVERSION
KITSAP COUNTY HUMAN SERVICES DEPARTMENT

4459 SE MILE HILL DRIVE
PORT ORCHARD, WA 98366

PROJECT # 2021056.01

BID SET

ISSUE DATE OCTOBER 23, 2023

REVISION SCHEDULE

1	ADDENDUM #2	11/29/2023

AHJ APPROVAL STAMP

COVER SHEET,
PROJECT
DESCRIPTION, SITE
ADDRESS & ZONING,
LEGAL DESCRIPTION,
DESIGN TEAM

SHEET #

A00.01

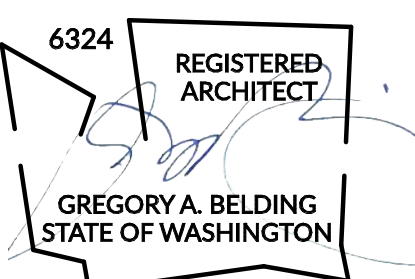

PACIFIC BUILDING CONVERSION
KITSAP COUNTY HUMAN SERVICES DEPARTMENT
4459 SE MILE HILL DRIVE
PORT ORCHARD, WA 98366

PROJECT # 2021056.01

BID SET

ISSUE DATE OCTOBER 23, 2023

REVISION SCHEDULE		
1	ADDENDUM #2	11/29/2023
A	ACUP RESPONSE #1	2/17/2023
B	22-06237 RESPONSE #1	7/27/2023

ARCHITECTURAL SITE PLAN

KEY PLAN

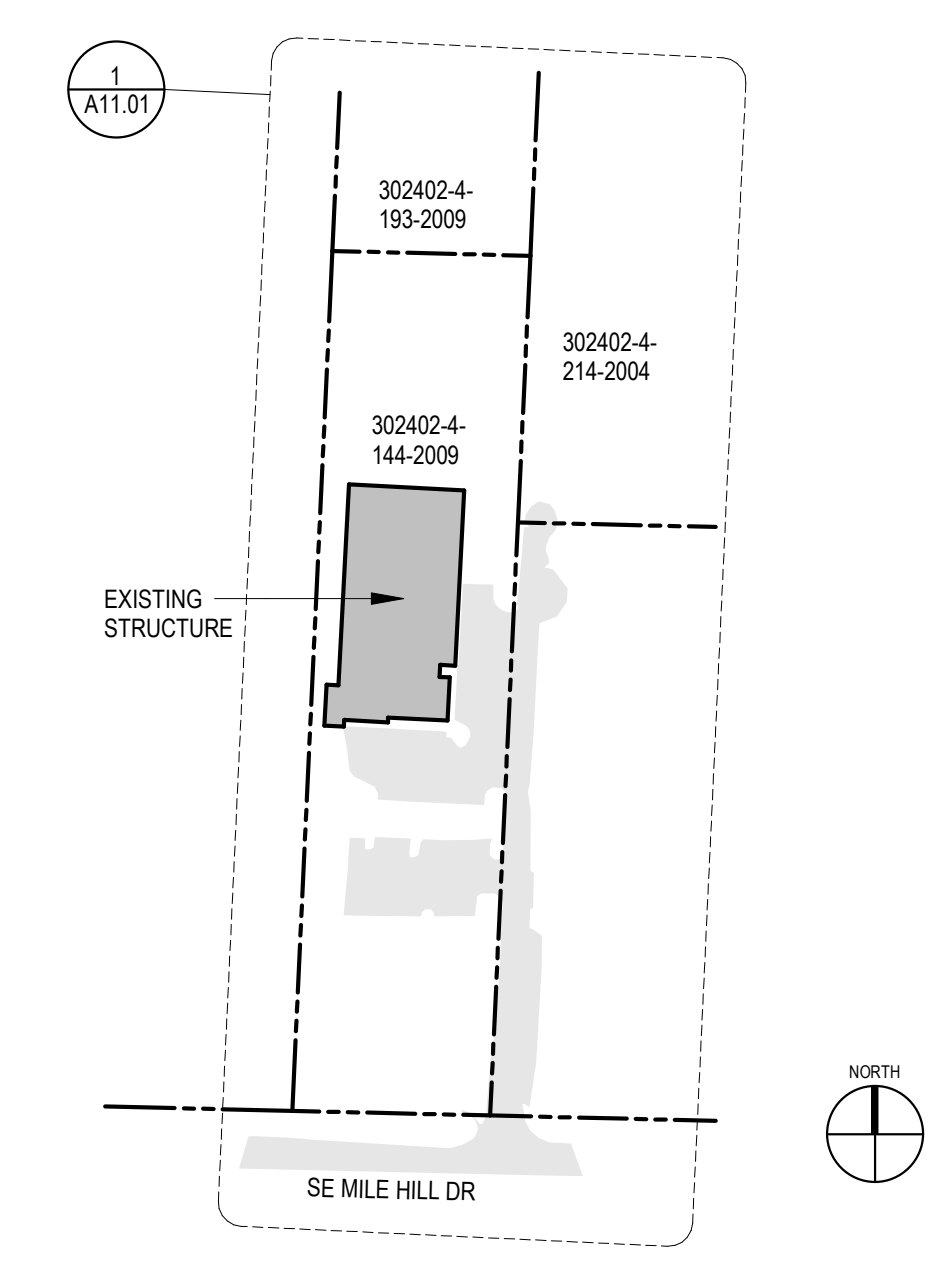

LEGEND

- LOT BOUNDARY
- - - EASEMENT
- - - GAS
- - - POWER
- - - SEWER
- - - STORM
- - - TELECOM
- - - WATER
- - - OTHER OVERHEAD UTILITIES
- X - X FENCE
- [Hatched Box] BUILDING FOOTPRINT/ ROOF OVERHANG
- [Grey Box] EXISTING IMPERVIOUS SURFACE TO REMAIN
- [Dark Grey Box] PROPOSED IMPERVIOUS SURFACE MAX 10,000 SF, SEE CIVIL
- [Dotted Box] GRAVEL
- [Camera Icon] CCTV SECURITY CAMERA

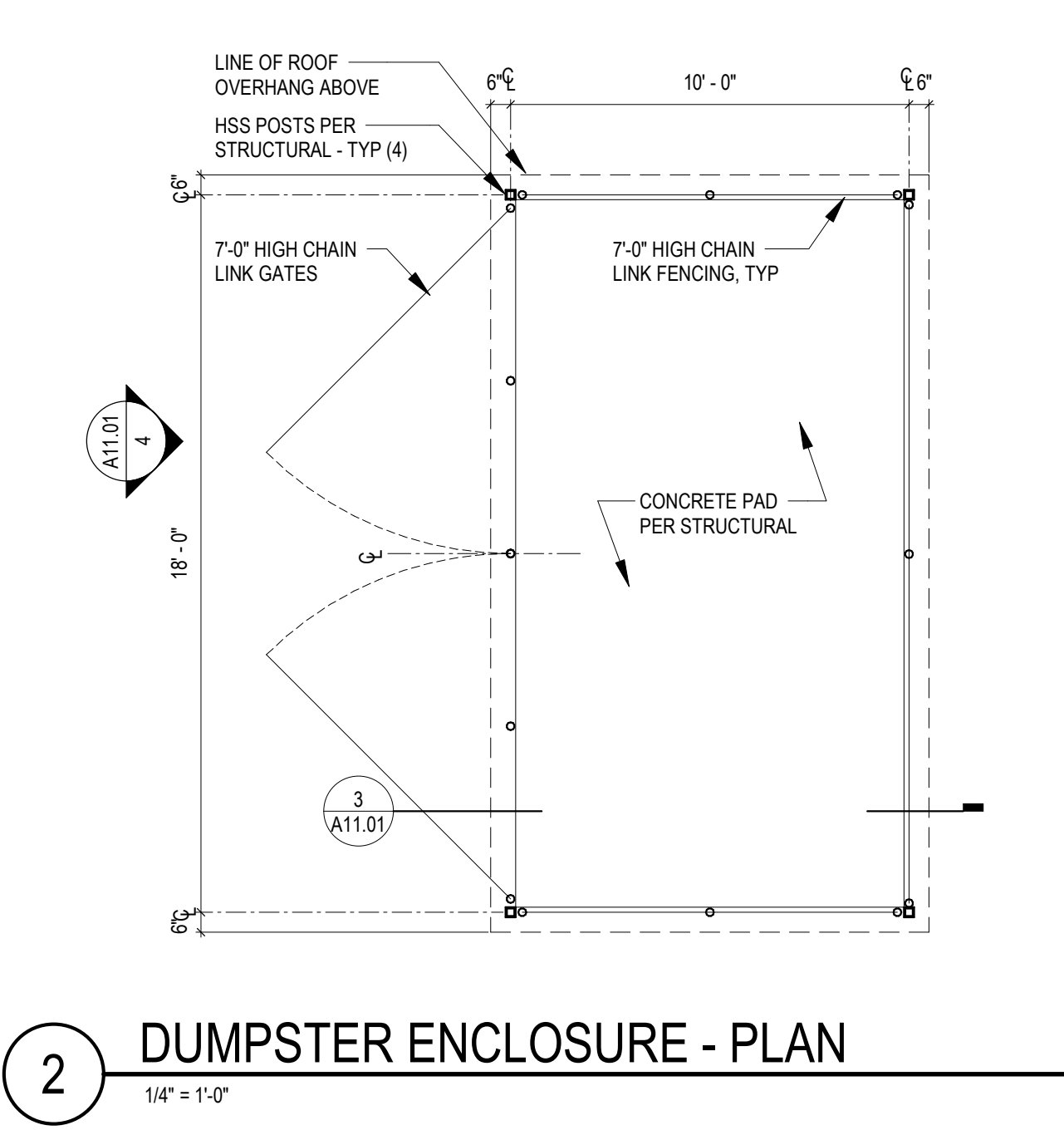

2 DUMPSTER ENCLOSURE - PLAN
1/4" = 1'-0"

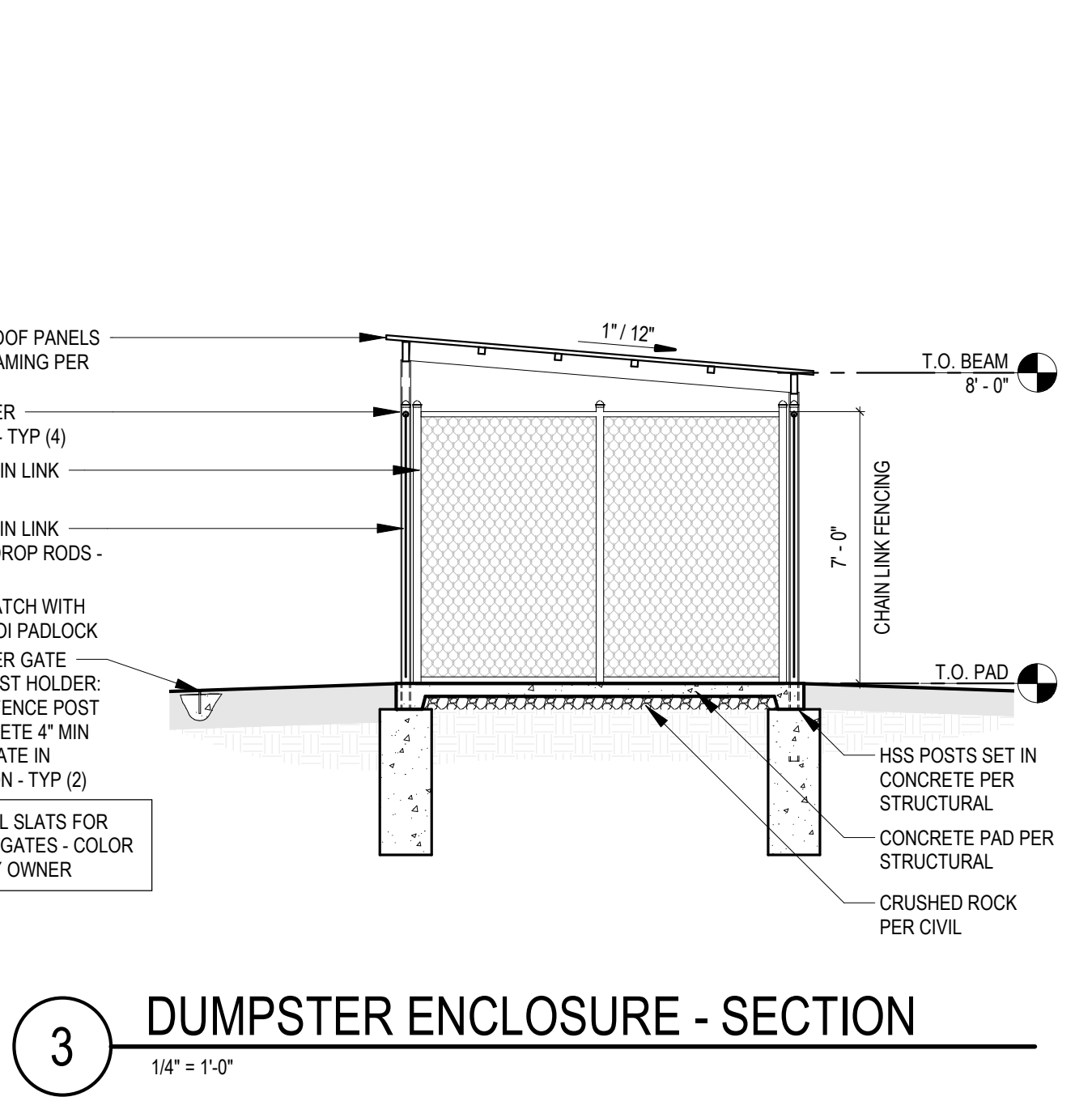

3 DUMPSTER ENCLOSURE - SECTION
1/4" = 1'-0"

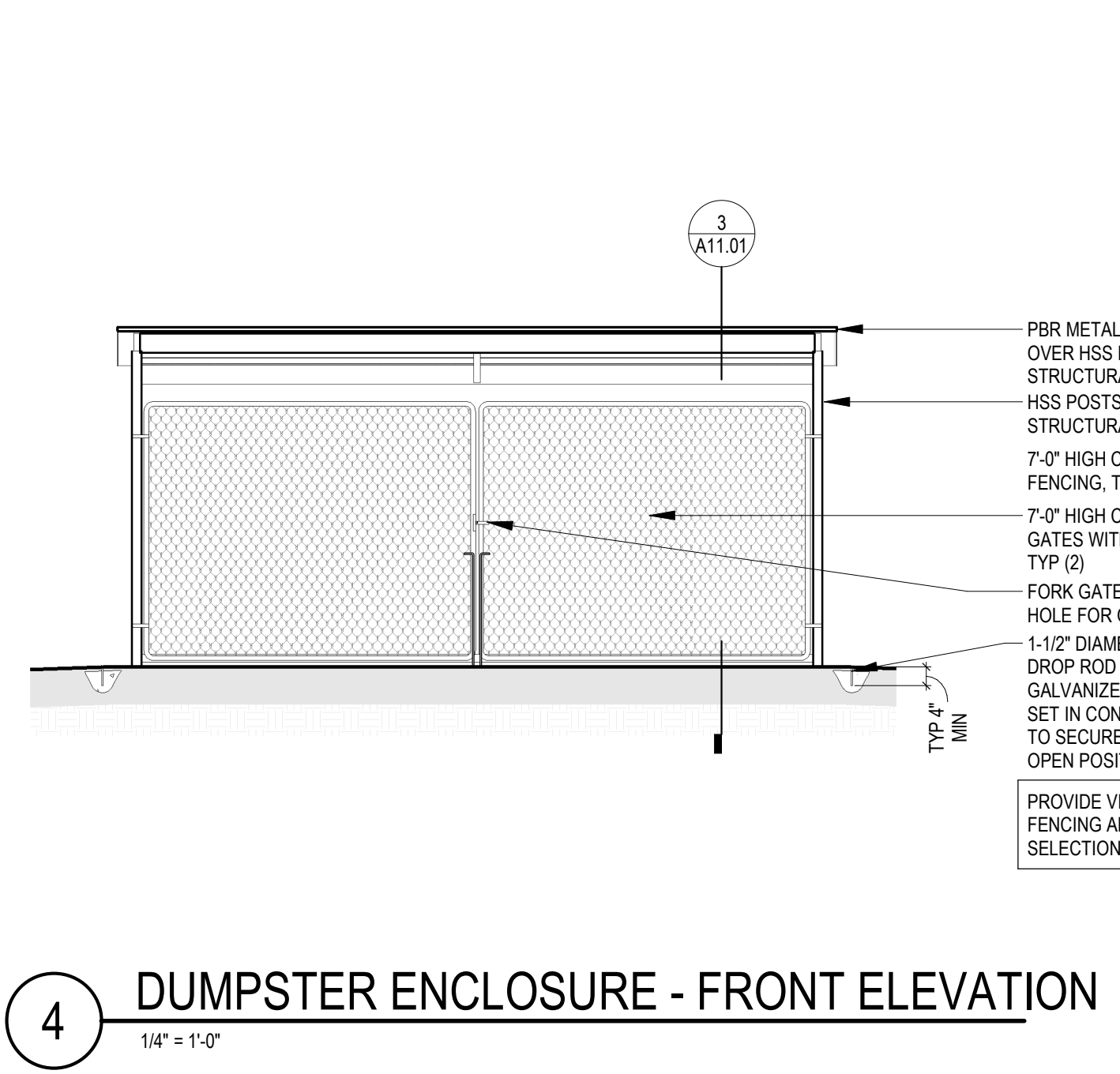

4 DUMPSTER ENCLOSURE - FRONT ELEVATION
1/4" = 1'-0"

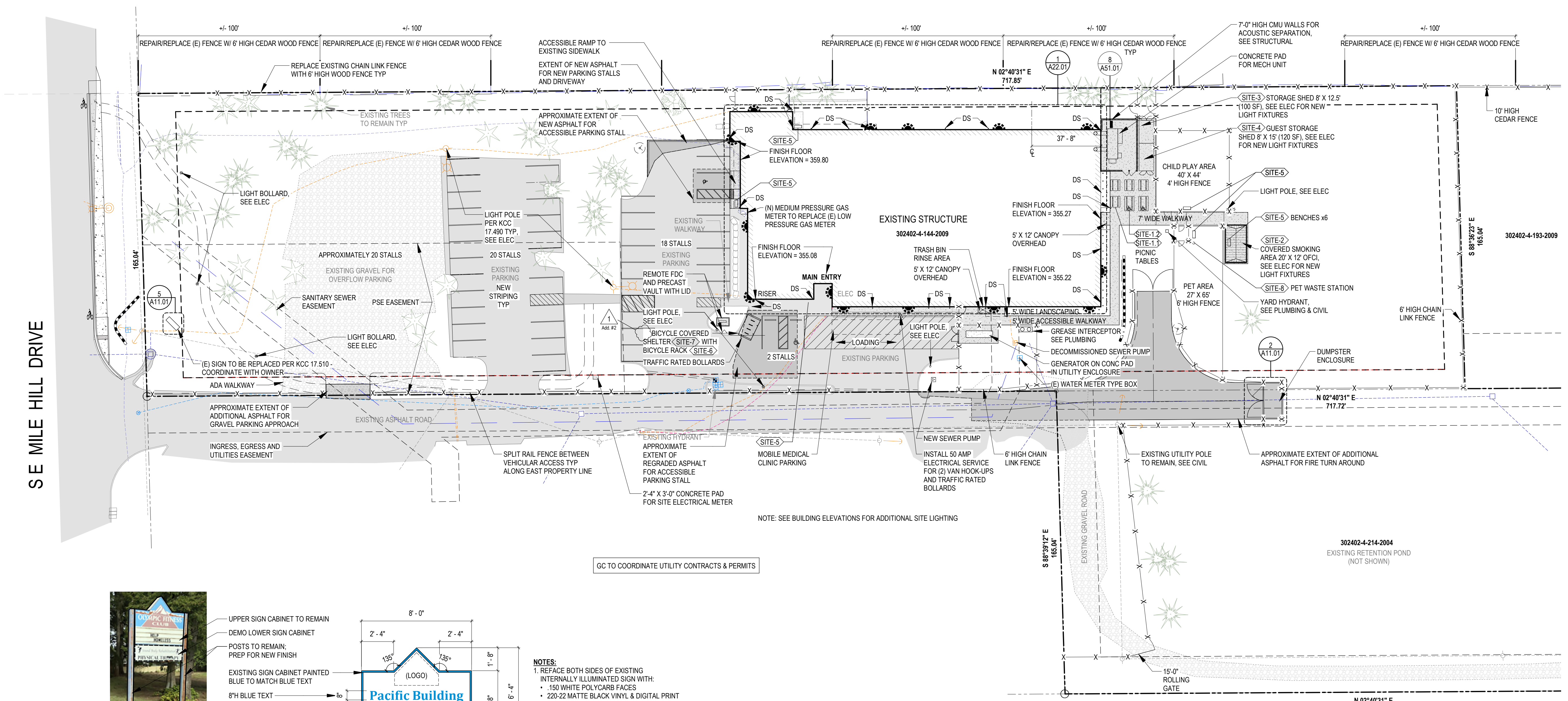

NOTE: SEE BUILDING ELEVATIONS FOR ADDITIONAL SITE LIGHTING

GC TO COORDINATE UTILITY CONTRACTS & PERMITS



- UPPER SIGN CABINET TO REMAIN
- DEMO LOWER SIGN CABINET
- POSTS TO REMAIN; PREP FOR NEW FINISH
- EXISTING SIGN CABINET PAINTED BLUE TO MATCH BLUE TEXT
- 8" BLUE TEXT
- 5" WHITE TEXT ON BLACK BACKGROUND
- 5" BLACK TEXT

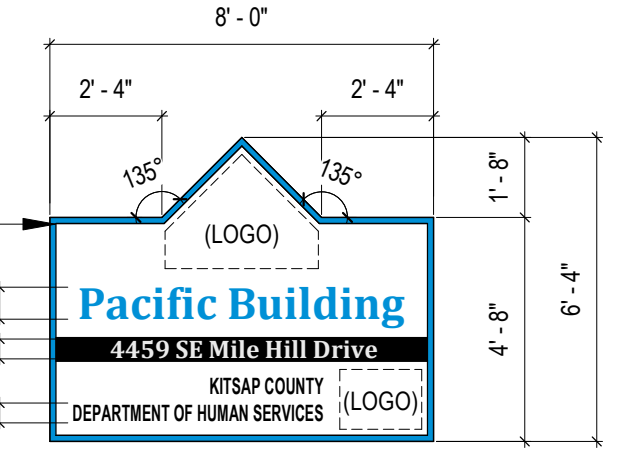

- NOTES:**
- REFACE BOTH SIDES OF EXISTING INTERNALLY ILLUMINATED SIGN WITH:
 - 150 WHITE POLYCARB FACES
 - 220-22 MATTE BLACK VINYL & DIGITAL PRINT
 2. PAINT EXISTING SIGN CABINET BLUE
 3. PAINT EXISTING SQUARE TUBE POST BLACK
 4. REPLACE EXISTING LIGHTING TO LED LIGHTS
 5. LOGOS SHALL BE PROVIDED BY OWNER

5 BUILDING SIGN REPLACEMENT
1/4" = 1'-0"

1 ARCHITECTURAL SITE PLAN
1" = 30'-0"

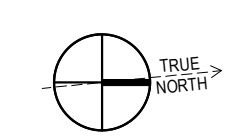

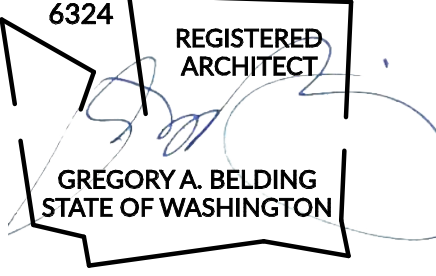

NOTES & LEGEND - SLAB PLAN

- 1. SEE STRUCTURAL FOR FOOTING REQUIREMENTS.
- 2. SLOPE TO FLOOR DRAINS.

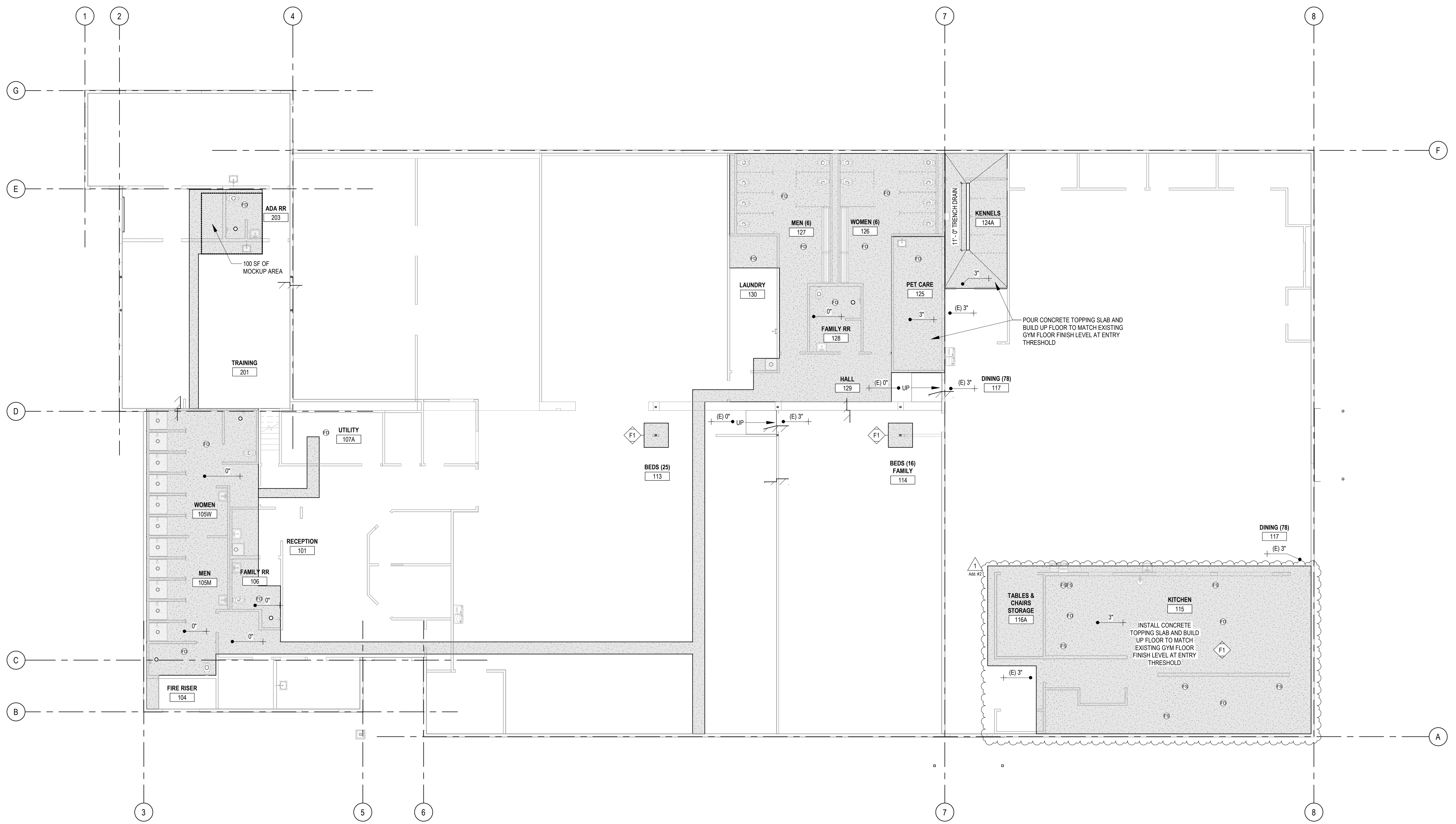
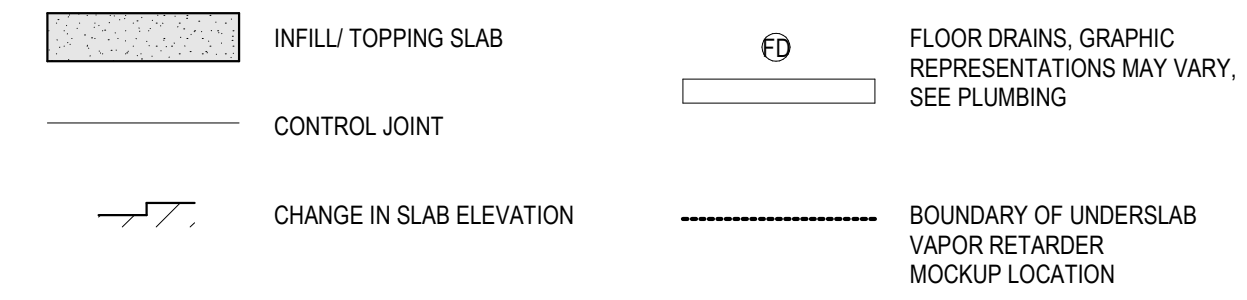

POUR CONCRETE TOPPING SLAB AND BUILD UP FLOOR TO MATCH EXISTING GYM FLOOR FINISH LEVEL AT ENTRY THRESHOLD

INSTALL CONCRETE TOPPING SLAB AND BUILD UP FLOOR TO MATCH EXISTING GYM FLOOR FINISH LEVEL AT ENTRY THRESHOLD.

1 SLAB PLAN
1/8" = 1'-0"
0 5 10

PACIFIC BUILDING CONVERSION
KITSAP COUNTY HUMAN SERVICES DEPARTMENT
4459 SE MILE HILL DRIVE
PORT ORCHARD, WA 98366

PROJECT # 2021056.01

BID SET

ISSUE DATE OCTOBER 23, 2023

REVISION SCHEDULE

NO.	REVISION	DATE
1	ADDENDUM #2	11/29/2023



SLAB PLAN

SHEET #

A21.01

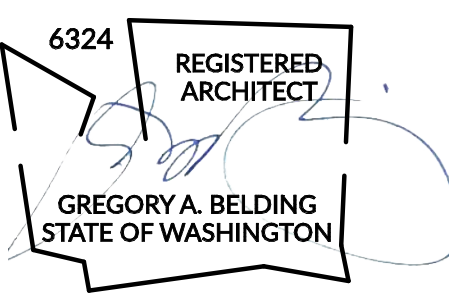

PACIFIC BUILDING CONVERSION
KITSAP COUNTY HUMAN SERVICES DEPARTMENT
4459 SE MILE HILL DRIVE
PORT ORCHARD, WA 98366

PROJECT #	2021056.01
BID SET	
ISSUE DATE	OCTOBER 23, 2023
REVISION SCHEDULE	
1	ADDENDUM #2 11/29/2023

AHJ APPROVAL STAMP

ROOF PLAN

SHEET #
A25.01

KEY NOTES - ROOF PLAN

#	NOTE DESCRIPTION
1	NEW ROOFING AND ASSOCIATED FLASHING AND ACCESSORIES THROUGHOUT, INCLUDING VENTS, GUTTERS, DOWNSPOUTS, AND COPING
2	NEW ROOF DRAIN AND ASSOCIATED GUTTERS AND DOWNSPOUTS. MODIFY ROOF SLOPE FOR POSITIVE ROOF DRAINAGE
3	EXISTING SKYLIGHT. DECOMMISSION OPERABILITY OF THE SKYLIGHT. INSPECT AND REPLACE SEALS.
4	ROOF EQUIPMENT CURB FOR MECHANICAL EQUIPMENT. SEE STRUCTURAL AND MECHANICAL
5	INSTALL NEW ASPHALT SHINGLE ROOFING. SEE DETAIL 6/A03.01
6	INSTALL NEW ROOF DRAIN. SEE PLUMBING
7	CANOPY BELOW. SEE EXTERIOR ELEVATIONS.
8	NEW MECHANICAL EQUIPMENT. SEE MECHANICAL
9	TYPE 1 HOOD EXHAUST. SEE FOOD SERVICE DRAWINGS
10	EXISTING ROOF CRICKET
11	NEW BUILT UP ROOF CRICKET SLOPED FOR POSITIVE ROOF DRAINAGE
12	KITCHEN HOOD EXHAUST. SEE ELECTRICAL

NOTES & LEGEND - ROOF PLAN

- 1. VERIFY EQUIPMENT CLEARANCES WITH MANUFACTURER REQUIREMENTS PRIOR TO INSTALL.
 - 2. FIELD CONFIRM DIMENSIONS AND REPORT DISCREPANCIES, IF ANY, TO ARCHITECT PRIOR TO CONSTRUCTION.
 - 3. DIMENSIONS ARE FROM ORIGIN, CENTERLINE OF ELEMENTS, OR FACE OF STRUCTURAL FRAMING, UNO.
 - 4. SEE EXTERIOR ELEVATION FOR LOCATIONS OF NEW WALL VENTS / LOUVERS NOT SHOWN.
 - 5. INSTALL NEW SHEATHING IN AREAS WHERE DAMAGED SHEATHING WAS IDENTIFIED AND REMOVED PRIOR TO INSTALLING NEW ROOFING.
-
- ROOF SLOPE PER PLAN
 - BUILDING OUTLINE BELOW
 - CHANGE IN ROOF ELEVATION
 - ROOF ASSEMBLY - SEE SHEET A03.01
 - ROOF WALKWAY PAD
 - EXISTING ELEMENT TO REMAIN
 - NEW CONSTRUCTION ELEMENT
 - NEW DOWNSPOUT AND GUTTERS - SEE EXTERIOR ELEVATIONS

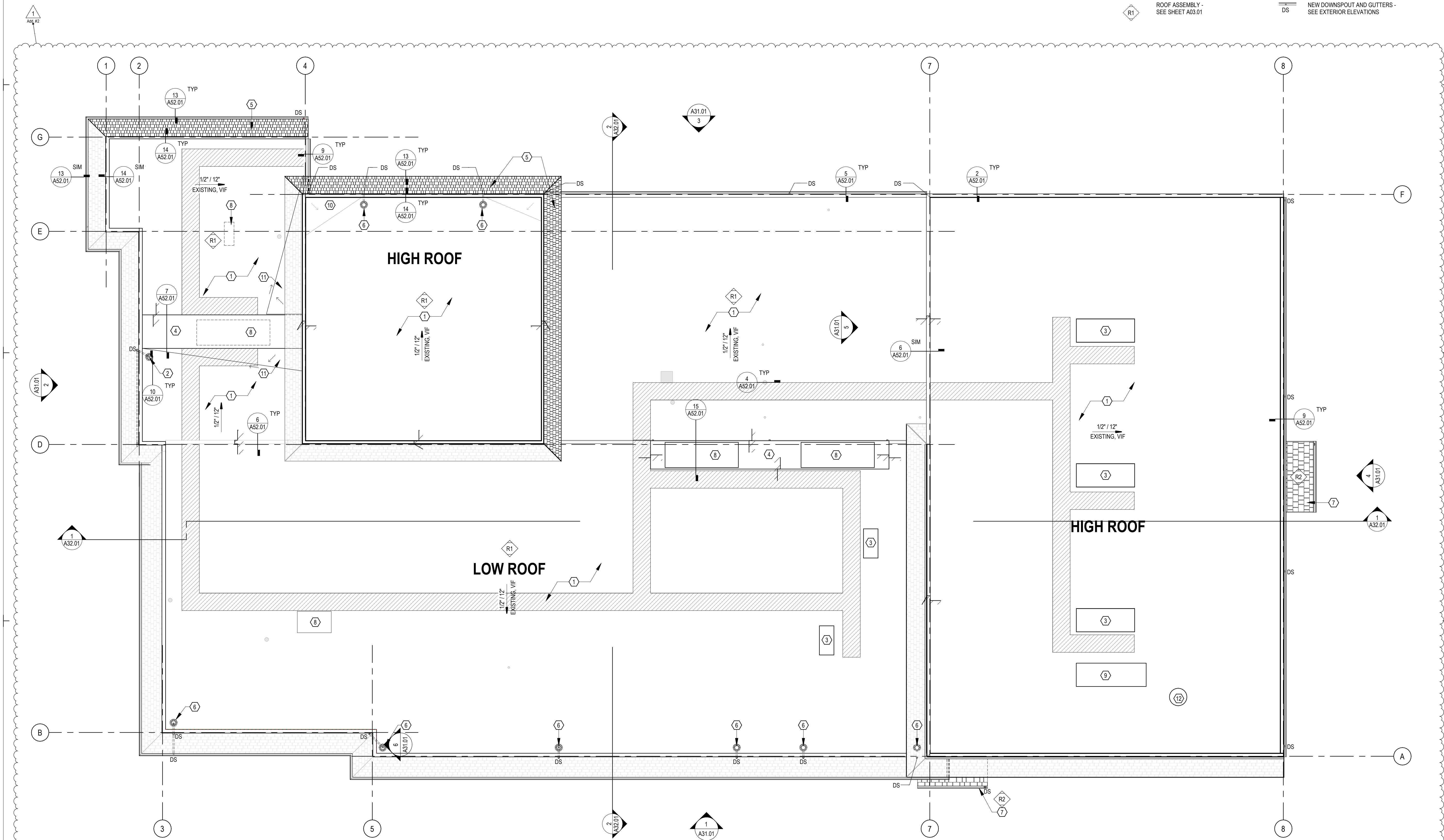

1 ROOF PLAN
1/8" = 1'-0"
0 5 10

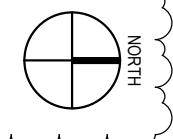

PROJECT #	2021056.01
BID SET	
ISSUE DATE	OCTOBER 23, 2023
REVISION SCHEDULE	
1	ADDENDUM #2 11/29/2023

AHJ APPROVAL STAMP

ENLARGED FLOOR PLANS - KITCHEN

KITCHEN EQUIPMENT SCHEDULE

NOTE: KITCHEN EQUIPMENT SHALL BE COMMERCIAL-GRADE AND CONTRACTOR FURNISHED AND INSTALLED, TYPICAL UNO

TAG	ITEM DESCRIPTION	REQUIREMENTS				NOTES
		BACKING	POWER (V)	EMERGENCY POWER	PLUMBING	
01	WALL SHELF	X	-	-	-	
02	CLEAN DISHTABLE	-	-	-	-	
03	DISHWASHER WITH BOOSTER HEATER (VENTLESS)	-	X	-	X	
04	SOILED DISHTABLE ASSEMBLY	-	-	-	-	
05	HAND SINK	X	-	-	X	
06	EYE WASH STATION	X	-	-	X	
10	ICE MACHINE	-	X	-	X	OFCI
11	2-DOOR REACH-IN REFRIGERATOR	-	X	-	-	OFCI
12	SERVING / FOOD PREP TABLE	-	-	-	-	OFOI (FOR WARMING KITCHEN FUNCTION)
13	MOBILE POT SHELVING	-	-	-	-	
14	POT WASHING SINKS	-	-	-	X	
15	UTENSIL RACK WITH SHELF	X	-	-	-	
16	MOP SINK CABINET	X	-	-	X	
22	EXHAUST HOOD WITH MAKE-UP AIR (TYPE 1)	X	X	-	-	
23	STAINLESS STEEL WALL FLASHING	X	-	-	-	
26	MOBILE CONVECTION OVEN	-	X	-	-	
28	32-GALLON WASTE/RECYCLING BIN	-	-	-	-	
35	DRY STORAGE SHELVING	-	-	-	-	
37	MOBILE REACH-IN FREEZER	-	X	-	-	
38	STAINLESS STEEL WALL GUARD	-	-	-	-	
39	STAINLESS STEEL COUNTERTOP	-	-	-	-	

FUTURE KITCHEN EQUIPMENT SCHEDULE (NOT IN CONTRACT)

TAG	ITEM DESCRIPTION	REQUIREMENTS				NOTES
		BACKING	POWER (V)	EMERGENCY POWER	PLUMBING	
07	SERVING COUNTER	-	-	-	-	
08	FOOD SHIELD	-	-	-	-	
09	HOT/COLD PAN (DROP-IN)	-	X	-	-	
17	TABLE-MOUNTED OVERSHELF WITH POT RACK	-	-	-	-	
18	ISLAND WORKTABLE	-	-	-	-	
19	MOBILE TRAY RACK	-	-	-	-	
20	WORKTABLE	-	-	-	-	
21	WALL SHELF	X	-	-	-	
24	MOBILE GRIDDLE WITH OVEN	-	X	-	-	
25	MOBILE (6) OIB RANGE WITH OVEN	-	X	-	-	
30	WORKTABLE WITH SINK	-	-	-	X	
31	WORKTABLE	-	-	-	-	
32	WALL SHELVING	X	-	-	-	
33	WORKTABLE WITH SINKS	-	-	-	X	
36	MOBILE REACH-IN REFRIGERATOR	-	X	-	-	
37	MOBILE REACH-IN FREEZER	-	X	-	-	

KEY NOTES - KITCHEN PLAN

#	NOTE DESCRIPTION
1	REFERENCE FUTURE KITCHEN PLAN FOR MEP CONNECTIONS TO BE PROVIDED IN THIS CONTRACT, CAP FOR FUTURE EQUIPMENT CONNECTIONS
2	FOLDING ATTIC LADDER WITH CEILING HATCH ABOVE FOR MECHANICAL MAINTENANCE ACCESS ON MEZZANINE
3	FUTURE KITCHEN LAYOUT PROVIDED TO CROSS-REFERENCE MEP SCOPE ONLY
4	FIRE RATED WALL - USE 5/8" TYPE 'X' GWB. PROVIDE JOINT FIRESTOPPING SEALANT AROUND PENETRATIONS AND AT TOP AND BOTTOM ON ALL SIDES OF WALL

- ### NOTES & LEGEND - FLOOR PLAN
- FIELD VERIFY DIMENSIONS AND REPORT DISCREPANCIES, IF ANY, TO ARCHITECT PRIOR TO CONSTRUCTION.
 - DIMENSIONS ARE FROM FACE OF EXISTING FINISH TO FACE OF STUD, CENTERLINE OF STRUCTURAL COLUMNS, OR CENTERLINE OF OPENINGS UNLESS NOTED OTHERWISE.
 - DIMENSIONS FROM FINISH FACE/OPENING TO FINISH FACE OF WALLS ARE REPRESENTED AS FOLLOWS:
 FINISH TO FINISH
 - DIMENSIONS NOTED WITH SUFFIX "CLR", "CLEAR", OR "MIN" ARE FROM FACE OF FINISH INCLUDING TRIM WORK UNLESS NOTED OTHERWISE.
 - DOORS NOT DIMENSIONED ARE LOCATED 4-1/2" TO INTERSECTING WALL OR CENTERED ON WALL.
 - FACE OF STUD ALIGNS WITH GRIDLINE UNLESS NOTED OTHERWISE.
 - PROVIDE BACKING/BLOCKING AT WALLS FOR INSTALLATION OF WALL-MOUNTED/ WALL-BRACED FIXTURES AND EQUIPMENT.
 - SEE INTERIOR ELEVATIONS AND FINISH PLAN FOR TYPES AND LOCATIONS OF FINISHES, FIXTURES, AND EQUIPMENT NOT INDICATED IN FLOOR PLAN.
 - PATCH AND REPAIR AREAS WHERE WATER DAMAGE HAS OCCURRED. FINISH TO MATCH ADJACENT SURFACE(S).
 - SITE ELEMENTS SHOWN FOR REFERENCE ONLY. SEE SITE PLAN FOR DETAILED SCOPE OF EXTERIOR WORK.
 - SEE ACCESSIBILITY GUIDELINES SHEET FOR ADDITIONAL INFORMATION NOT INDICATED IN FLOOR PLAN.
 - INSTALL NEW SHEATHING IN AREAS WHERE DAMAGED SHEATHING WAS IDENTIFIED AND REMOVED.
-
- | | |
|---|-----------------------------------|
| --- ROOF OVERHANG | ○ 5' DIAMETER TURNING SPACE |
| □ OFOI (OWNER FURNISHED OWNER INSTALLED) ITEMS SHOWN FOR COORDINATION; SEE FFE SCHEDULE FOR OFCI (OWNER FURNISHED CONTRACTOR INSTALLED) ITEMS | □ CLEAR FLOOR SPACE 30' X 48' UNO |
| --- IN-WALL 3/4" PLYWOOD BACKING FOR OFCI & OFOI ITEMS | ⌋ EXISTING ELEMENT TO REMAIN |
| | ⌋ NEW CONSTRUCTION ELEMENT |

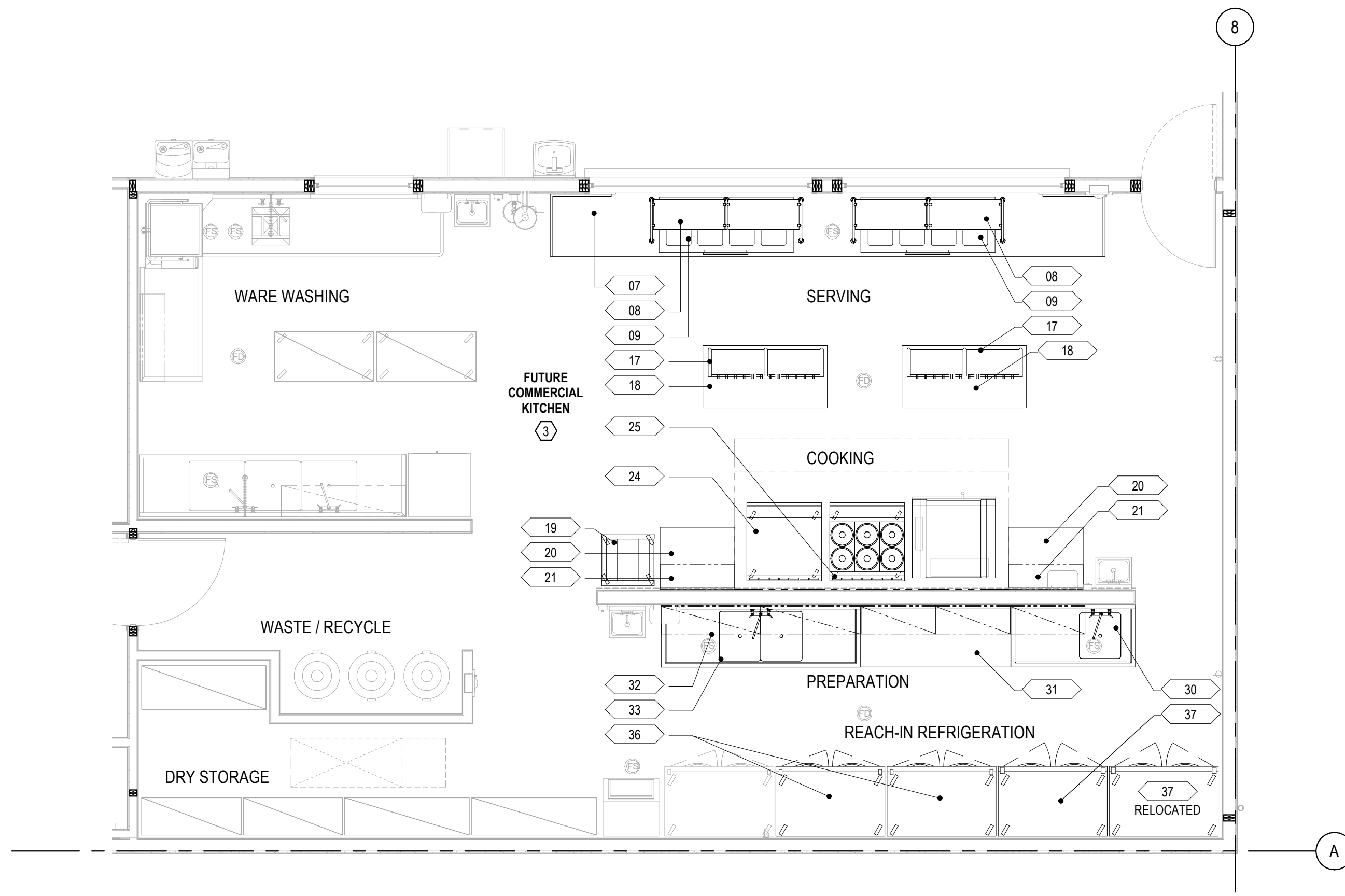

2 ENLARGED FLOOR PLAN - FUTURE KITCHEN (NOT IN CONTRACT)
 1/4" = 1'-0"

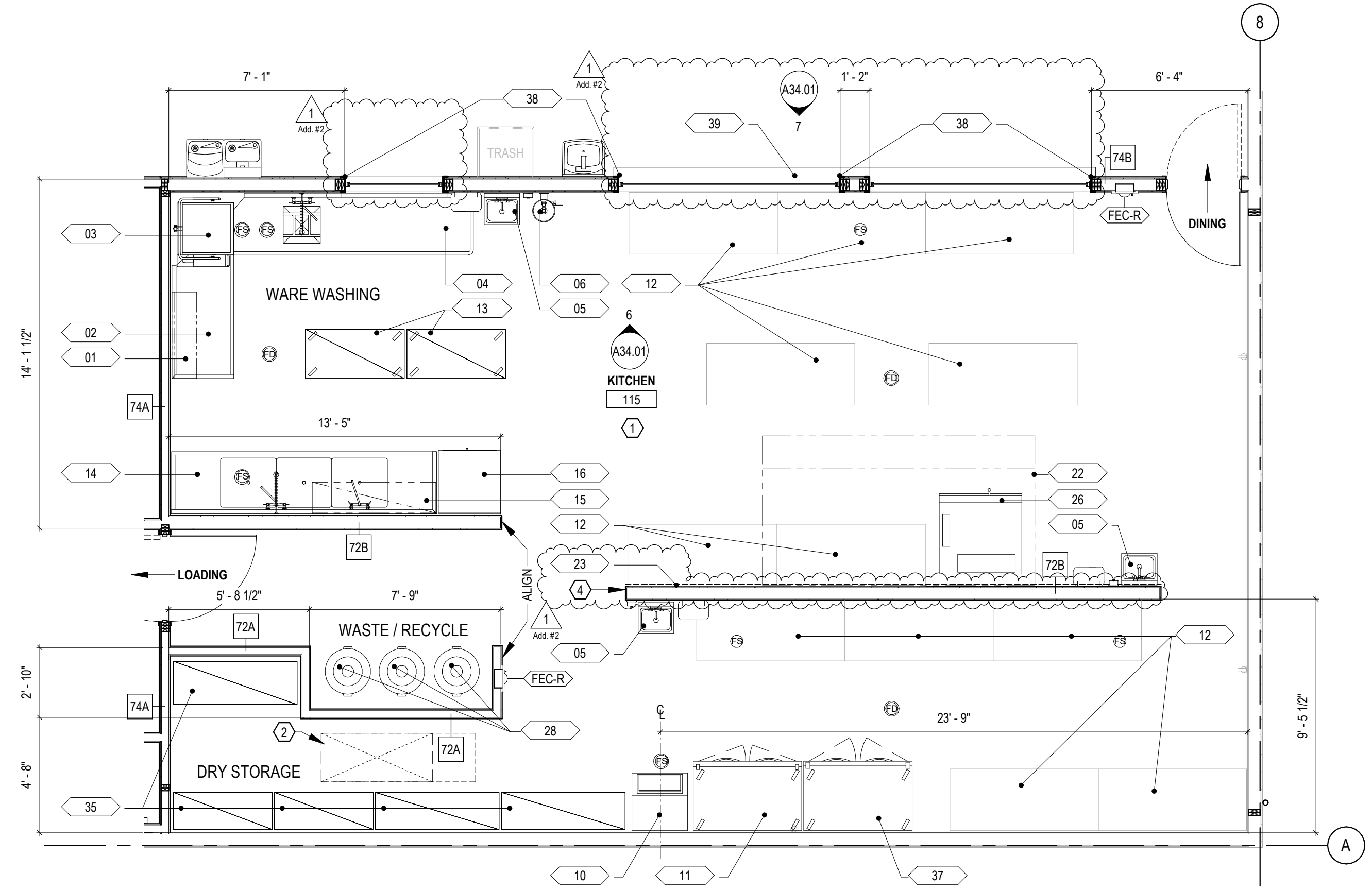

1 ENLARGED FLOOR PLAN - KITCHEN
 1/4" = 1'-0"

TYPICAL MOUNTING HEIGHTS

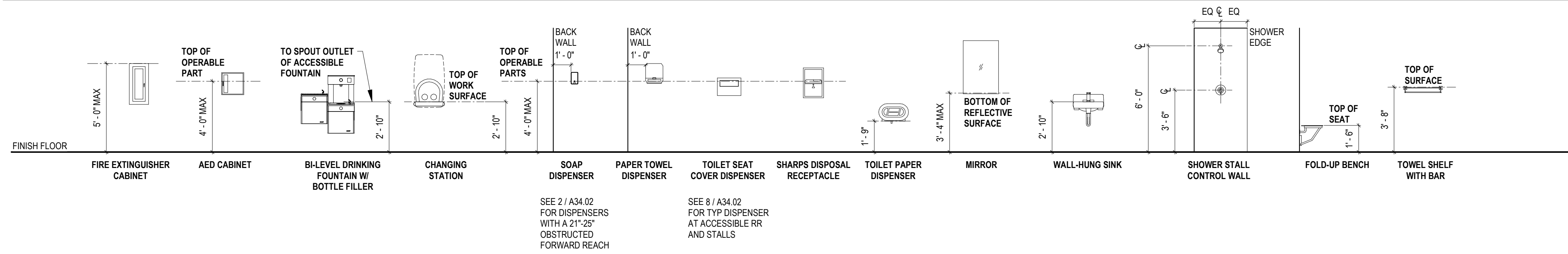

NOTES & LEGEND - INTERIOR ELEVATIONS

1. REFERENCE FINISH PLAN FOR TYPICAL ROOM FINISHES NOT SHOWN.
2. REFERENCE TYPICAL MOUNTING HEIGHTS UNLESS MOUNTING HEIGHT IS NOTED OTHERWISE.
3. GRAPHIC REPRESENTATION OF MATERIALS AND/OR FIXTURES MAY NOT BE TO SCALE.
4. INSULATE EXPOSED PLUMBING BELOW WALL MOUNT SINKS TYP.
5. PROVIDE BACKING/BLOCKING AT WALLS FOR INSTALLATION OF ALL WALL-MOUNTED FIXTURES AND EQUIPMENT.
6. OUTLETS SHOWN FOR COORDINATION PURPOSES ONLY. REFER TO ELECTRICAL DRAWINGS FOR FULL SCOPE.

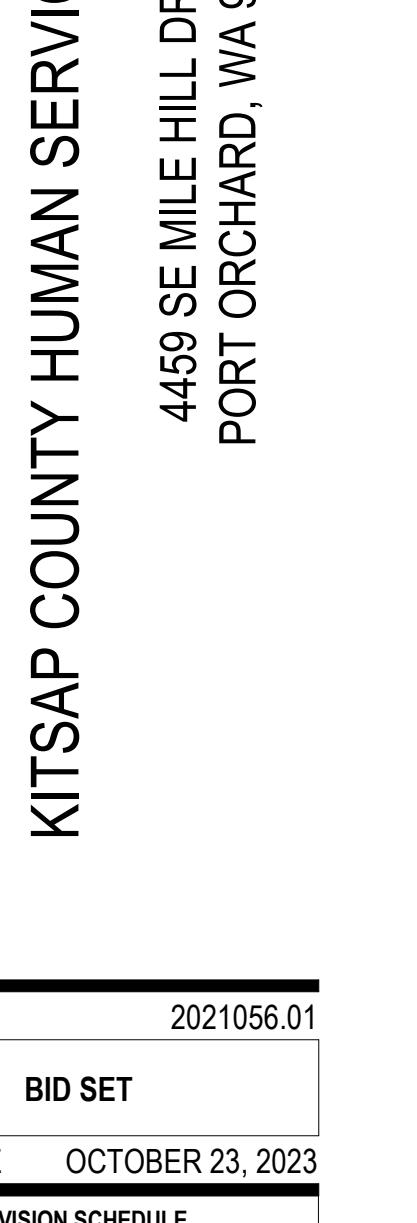
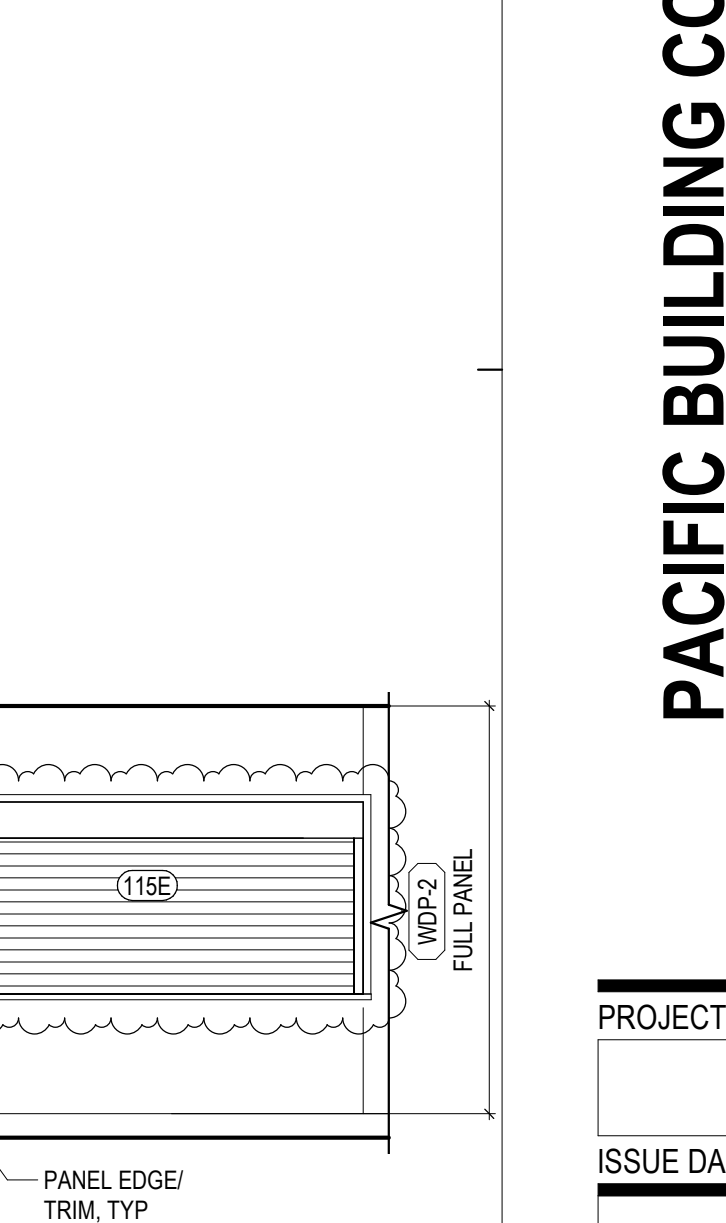
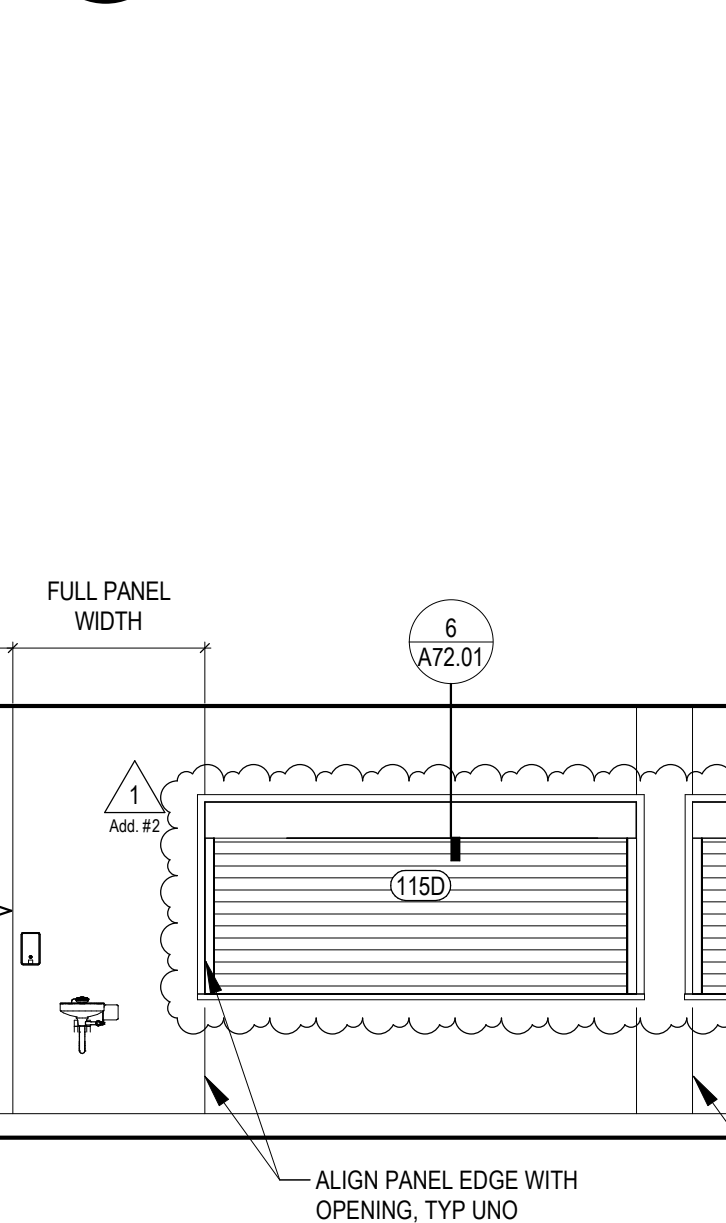
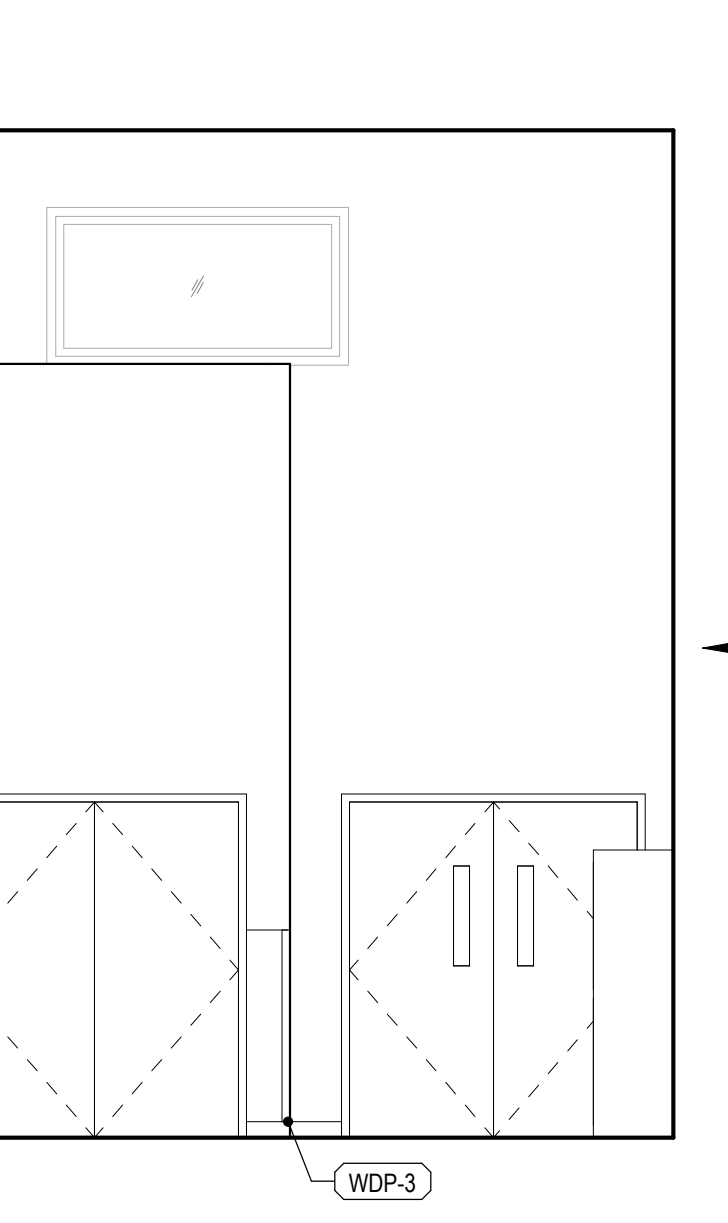
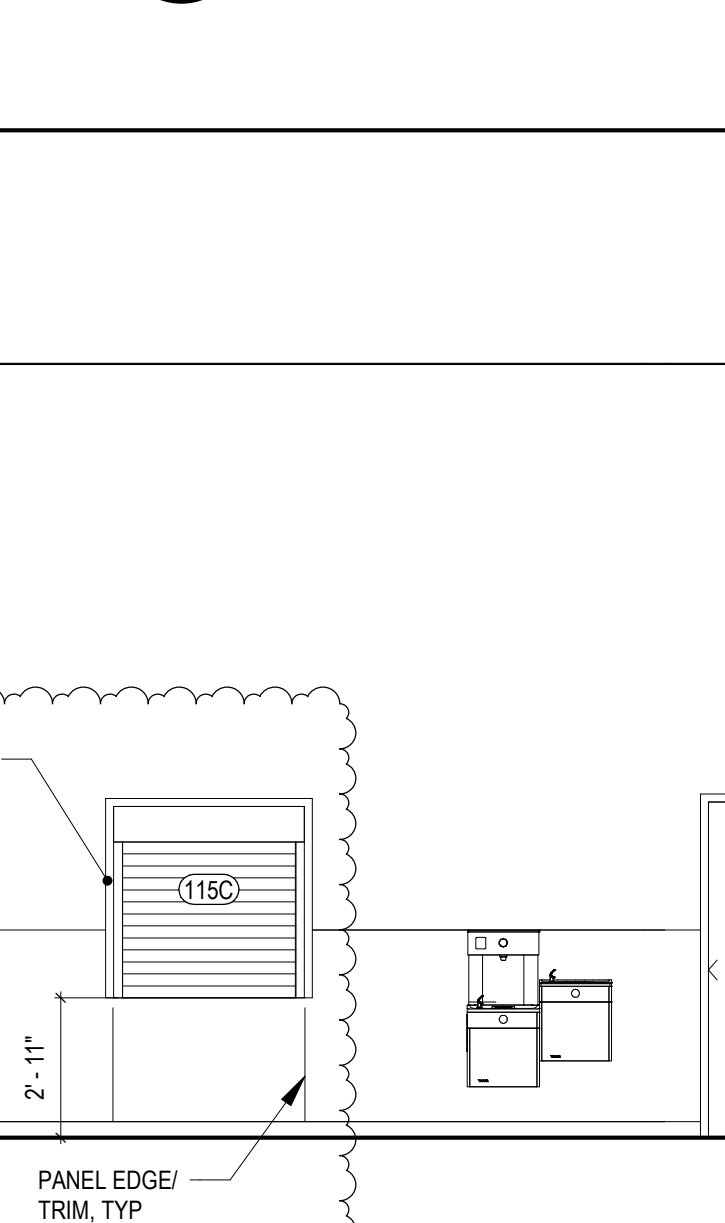
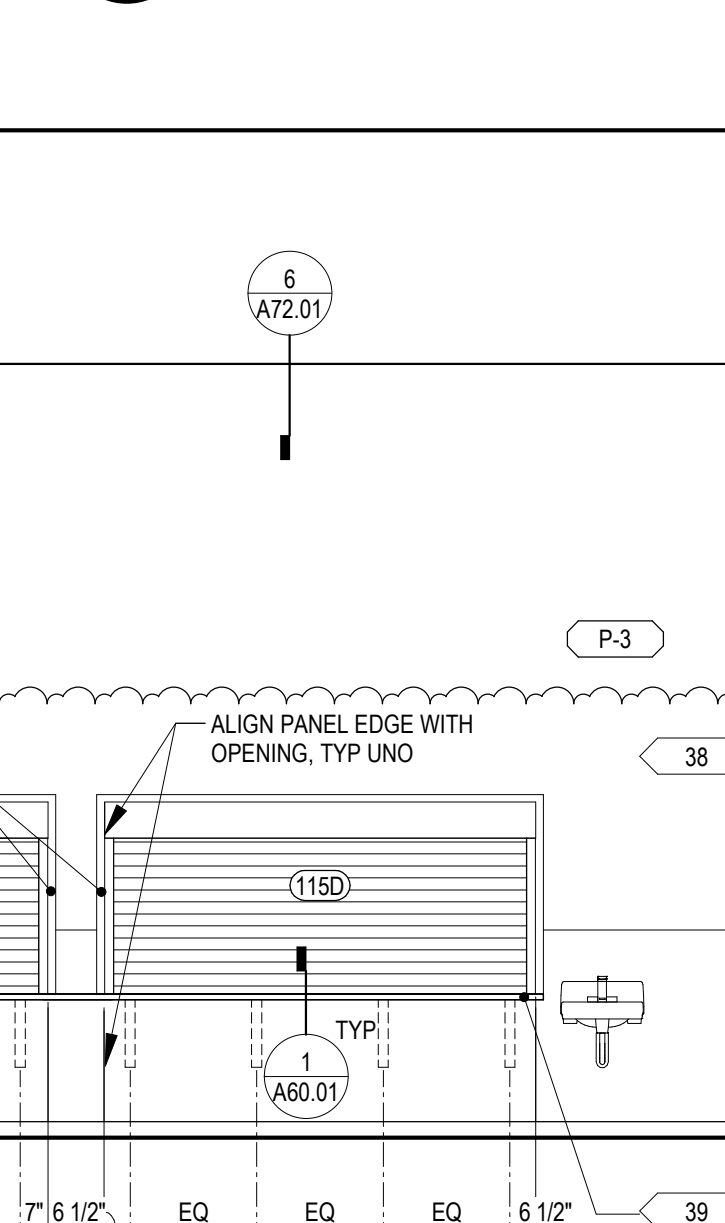
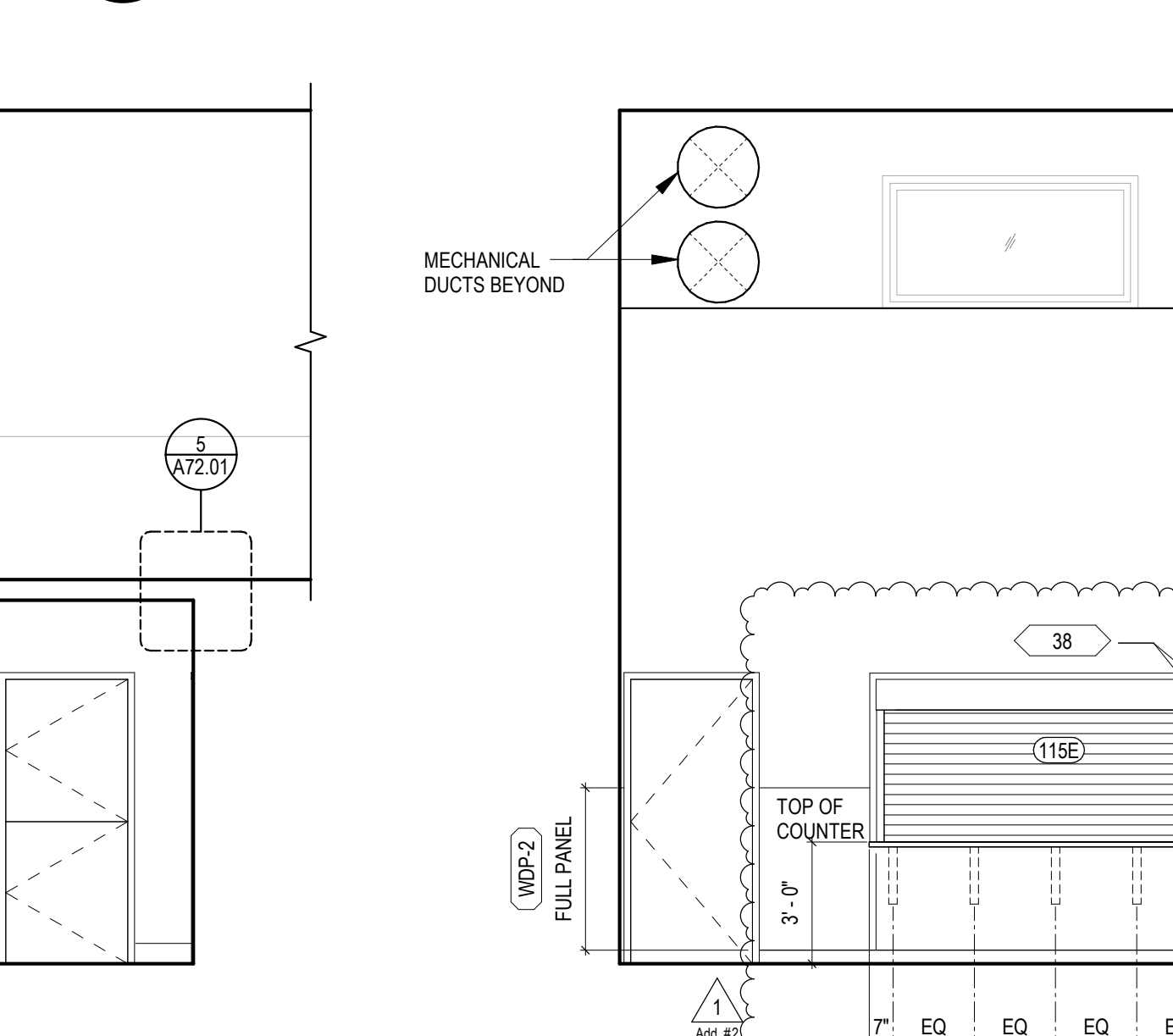
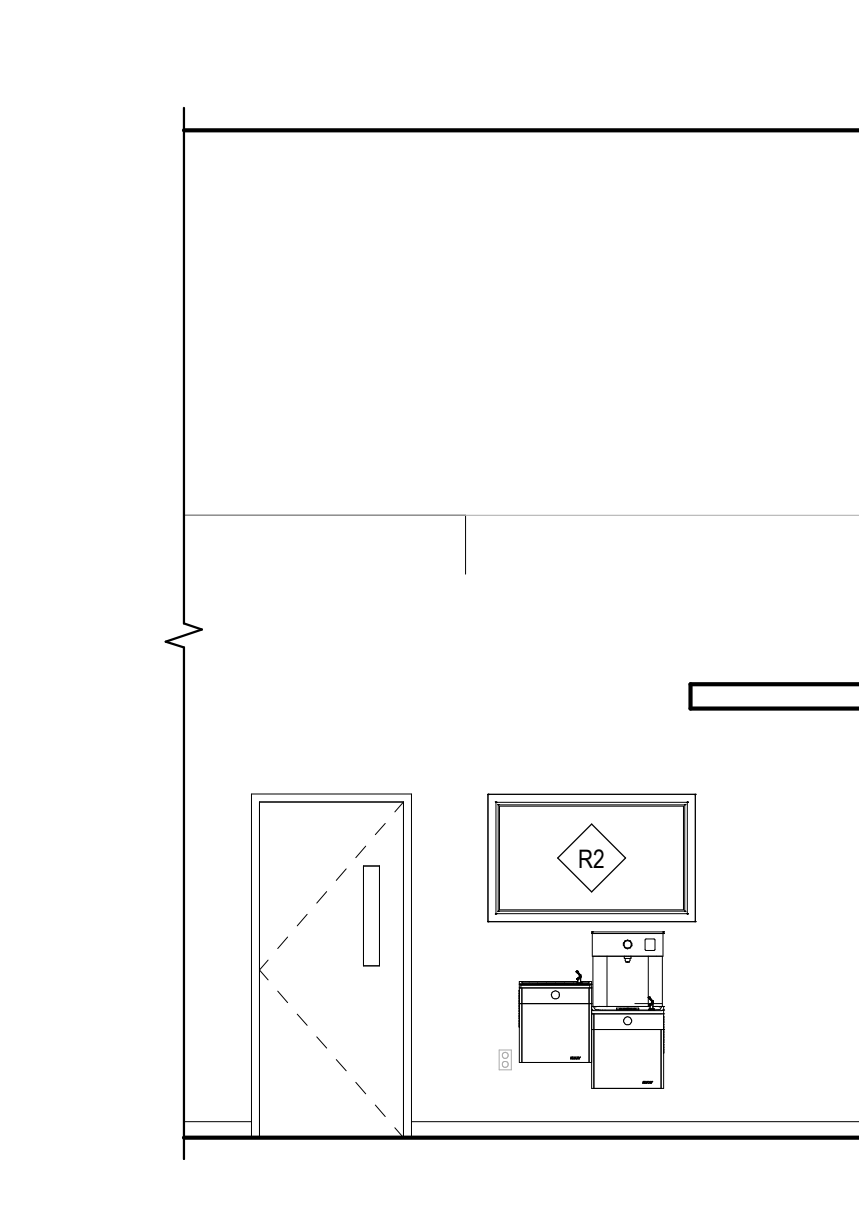
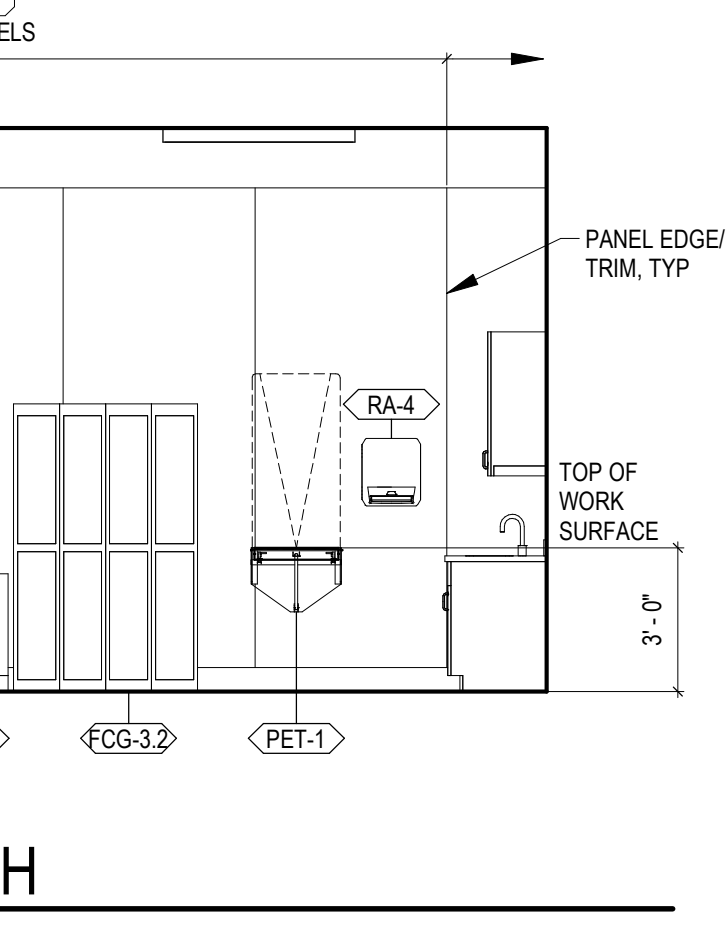
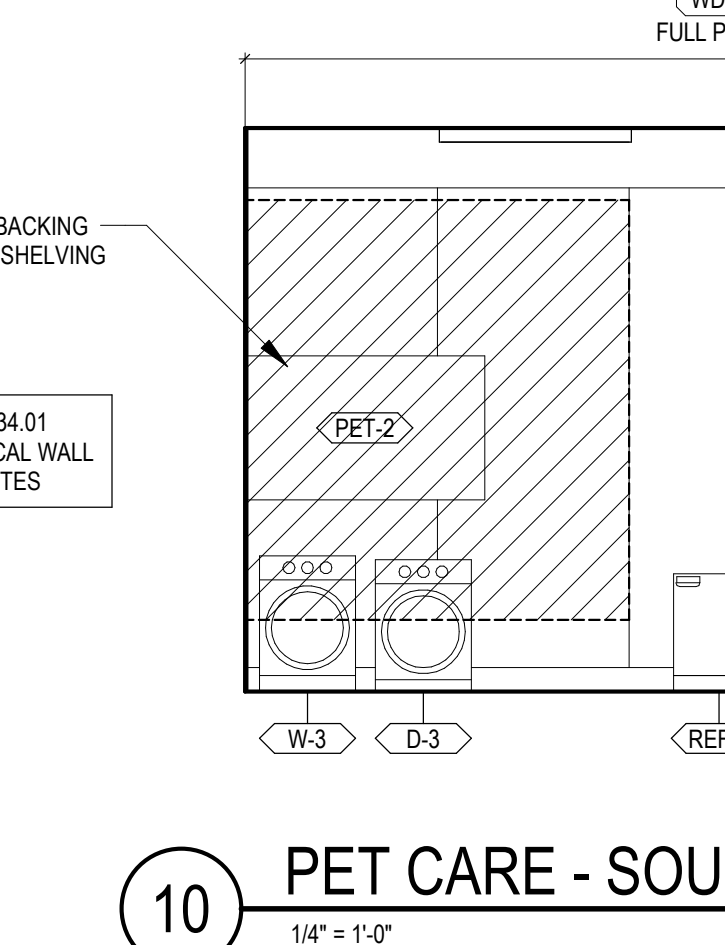
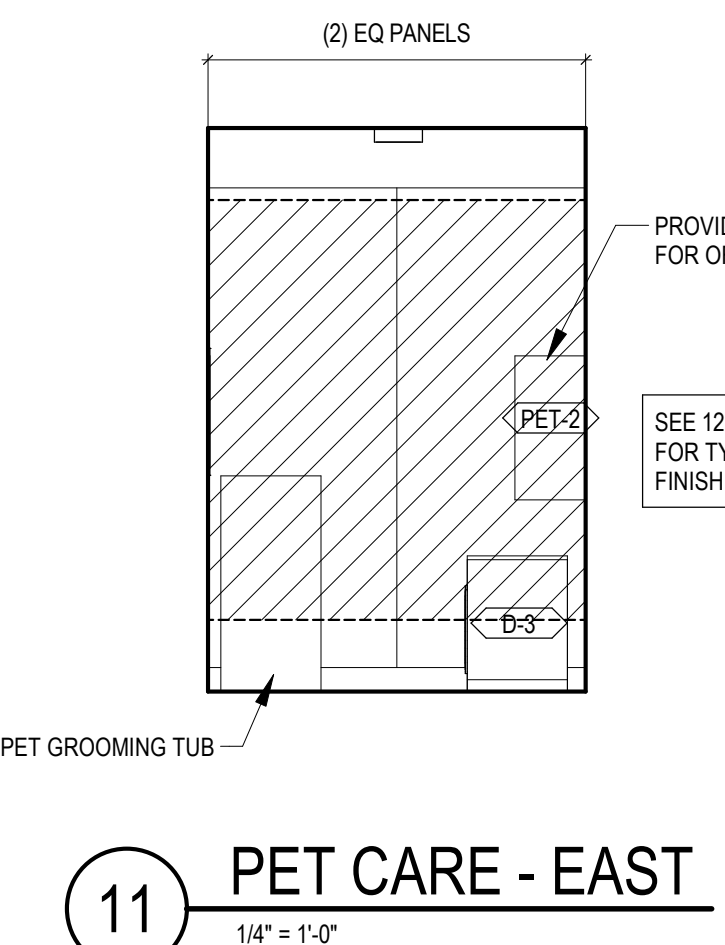
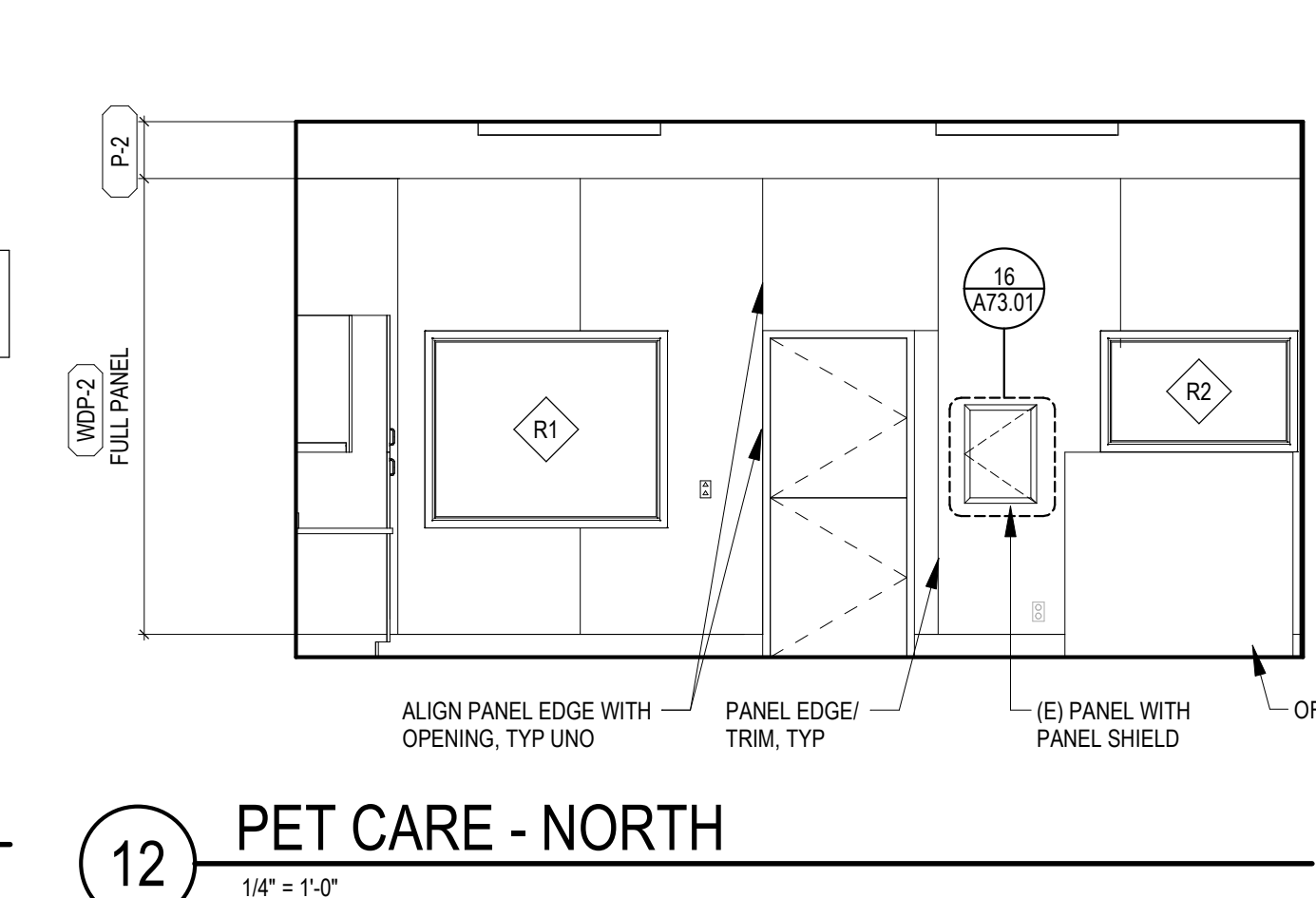
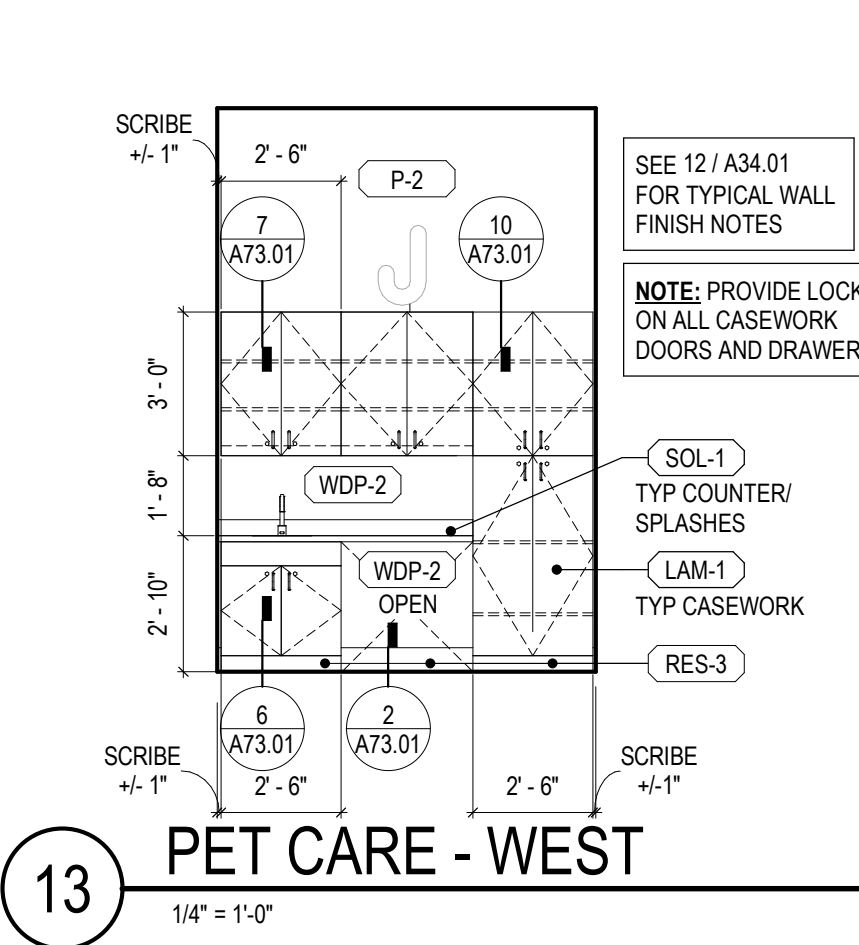
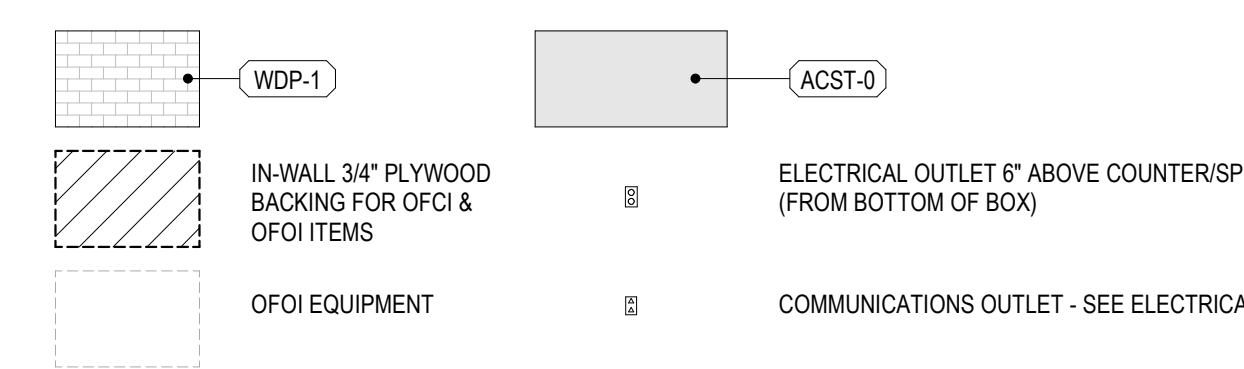

PROJECT # 2021056.01

BID SET

ISSUE DATE OCTOBER 23, 2023

REVISION SCHEDULE	
1	ADDENDUM #2 11/29/2023

AHJ APPROVAL STAMP

INTERIOR ELEVATIONS

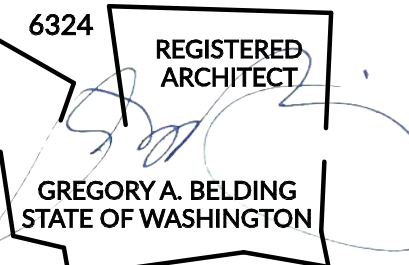

PROJECT # 2021056.01

BID SET

ISSUE DATE OCTOBER 23, 2023

REVISION SCHEDULE

NO.	REVISION	DATE
1	ADDENDUM #2	11/29/2023

AHJ APPROVAL STAMP

CEILING DETAILS

SHEET #

A72.01

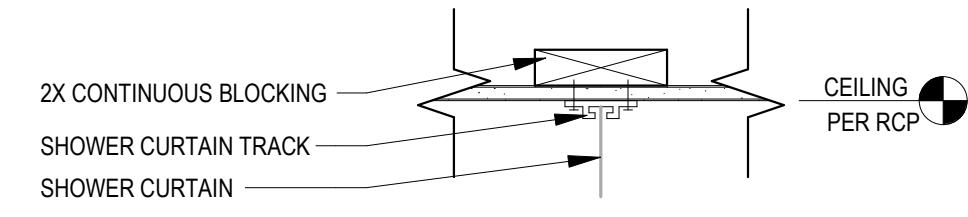

NOTE: SIMILAR CONDITION AT TOILET & SHOWER PARTITIONS - SEE STRUCTURAL

12 SHOWER CEILING TRACK DETAIL
1 1/2" = 1'-0"

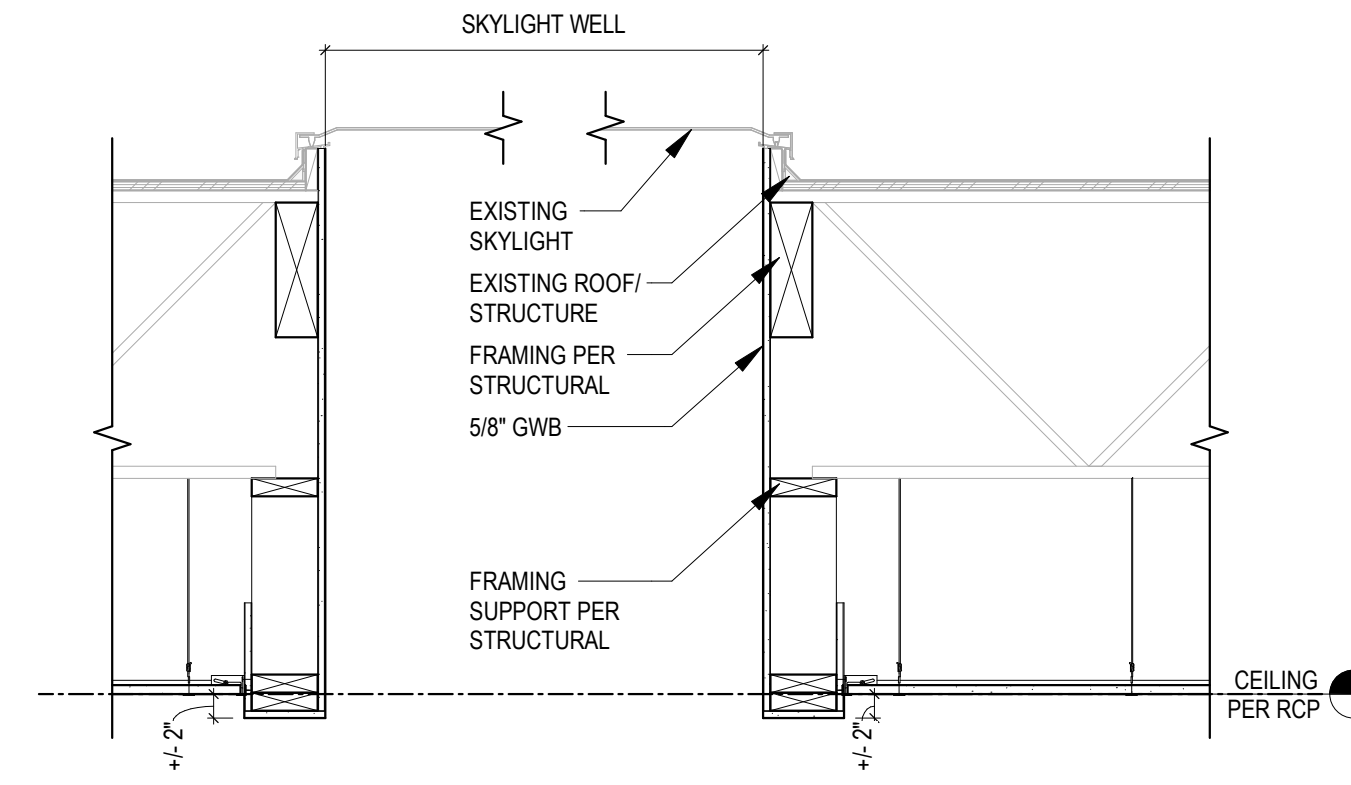

8 ACT AT SKYLIGHT
3/4" = 1'-0"

PERIMETER SUPPORT ANGLE:

- THE PERIMETER SUPPORT ANGLE SHALL SUPPLY A SUPPORT LEDGE OF NOT LESS THAN 2" OR MANUFACTURER ASSEMBLY APPROVED FOR USE IN SEISMIC ZONES D, E OR F.
- MAIN RUNNER OR CROSS RUNNER ENDS, OR BOTH, SHALL BE ATTACHED TO THE PERIMETER ON TWO ADJACENT WALLS. A CLEARANCE OF 3/4" SHALL BE MAINTAINED BETWEEN THE MAIN RUNNER AND CROSS RUNNER ENDS AND THE PERIMETER MEMBERS ON THE TWO OPPOSITE WALLS. ON THE WALLS WHERE THE TERMINAL END RUNNERS ARE NOT FIXED TO THE PERIMETER SUPPORTING CLOSURE, ALLOW FOR 3/4" AXIAL MOVEMENT.

SUSPENSION WIRE:

- MIN 12 GA STEEL WIRE
- 8" MAX FROM WALL ON ALL TERMINAL ENDS OF RUNNERS
- 4'-0" OC ALONG EACH MAIN RUNNER

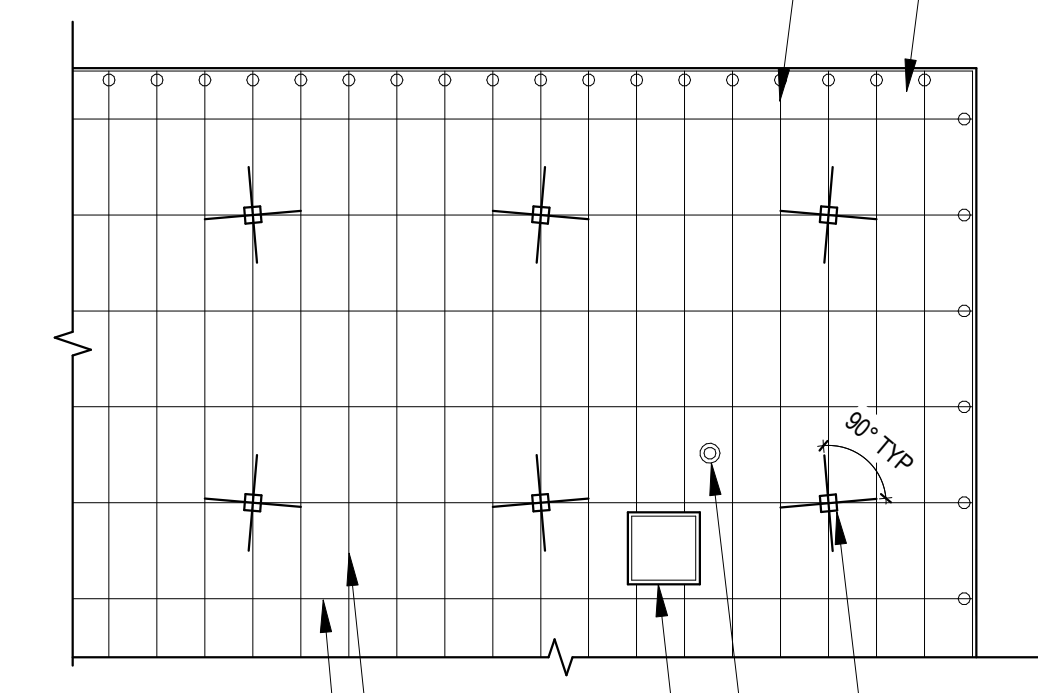

PLAN DIAGRAM

MAIN RUNNER, SPACING VARIES, TYP
CROSS RUNNER, SPACING VARIES, TYP

ALL CEILING PENETRATIONS (COLUMNS ETC.) AND INDEPENDENTLY SUPPORTED FIXTURES OR SERVICES SHALL BE CONSIDERED AS PERIMETER CLOSURES THAT ALSO MUST ALLOW THE REQUIRED CLEARANCES BY USING SUITABLE CLOSURE DETAIL.

SPRINKLER HEADS AND OTHER PENETRATIONS SHALL HAVE A 2" OVERSIZE RING, SLEEVE OR ADAPTER THROUGH THE CEILING TILE TO ALLOW FOR FREE MOVEMENT OF AT LEAST 1" IN ALL HORIZONTAL DIRECTIONS.

HORIZONTAL RESTRAINT POINT (SEE DIAGRAM BELOW):

- COMPRESSION POST AND BRACING WIRES
- 12'-0" OC IN BOTH DIRECTIONS WITH THE FIRST POINT WITHIN 6'-0" FROM EACH WALL.

BRACING WIRES:

- (4) 12 GA WIRES ATTACHED TO THE MAIN BEAM. WIRES ARE ARRANGED 90° FROM EACH OTHER & AT AN ANGLE NOT EXCEEDING 45° FROM THE PLANE OF CEILING.
- WIRES ARE TO BE WITHIN 2" OF THE CONNECTION OF THE VERTICAL STRUT TO SUSPENDED CEILING.

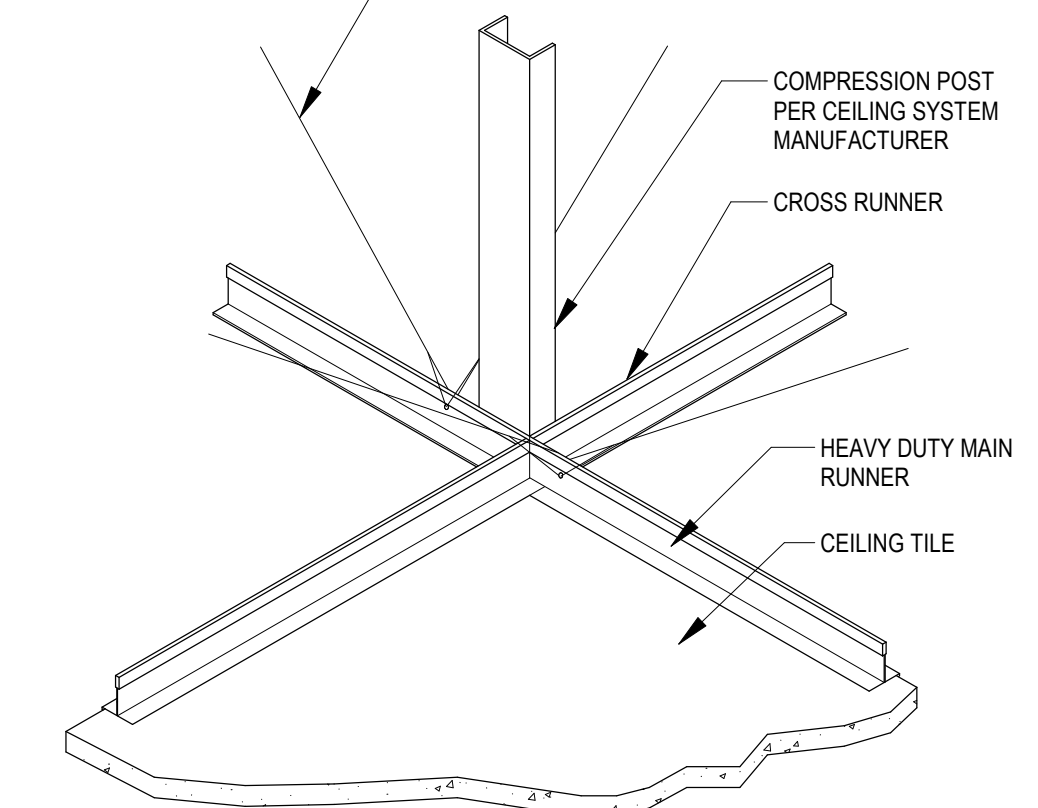

LATERAL FORCE BRACING DIAGRAM

NOTES:

- SUSPENDED CEILING SYSTEM INSTALLATION SHALL BE INSTALLED PER IBC 2018 (IBC 808 AND IBC 1604.9), ASCE 7-10, AND ASTM E980.
- THIS DETAIL APPLIES TO SEISMIC DESIGN CATEGORIES D, E, AND F.
- SPREADER (SPACER) BARS OR OTHER MEANS APPROVED BY THE LOCAL BUILDING DEPT. SHALL BE USED TO PREVENT ENDS OF MAIN BEAMS AT PERIMETER WALLS FROM SPREADING OPEN DURING A SEISMIC EVENT. PERIMETER WIRES SHALL NOT BE USED IN LIEU OF SPREADER BARS.
- FOR CEILING AREAS EXCEEDING 2,500 SF, A SEISMIC SEPARATION JOINT OR FULL HEIGHT PARTITION THAT BREAKS THE CEILING UP INTO AREAS NOT EXCEEDING 2,500 SF, EACH WITH A RATIO OF THE LONG TO SHORT DIMENSION LESS THAN OR EQUAL TO 4, SHALL BE PROVIDED UNLESS STRUCTURAL ANALYSES ARE PERFORMED OF THE CEILING BRACING SYSTEM FOR THE PRESCRIBED SEISMIC FORCES THAT DEMONSTRATE CEILING PENETRATIONS AND CLOSURE ANGLES OR CHANNELS PROVIDE SUFFICIENT CLEARANCE TO ACCOMMODATE THE ANTICIPATED LATERAL DISPLACEMENT. EACH AREA SHALL BE PROVIDED WITH CLOSURE ANGLES OR CHANNELS IN ACCORDANCE WITH THE PERIMETER SUPPORT ANGLE DESCRIBED ABOVE AND HORIZONTAL RESTRAINTS OR BRACING.
- CHANGES IN CEILING PLANE ELEVATION SHALL HAVE INDEPENDENT POSITIVE BRACING.
- PARTITIONS THAT ARE TIED TO THE CEILING AND ALL PARTITIONS GREATER THAN 6 FEET IN HEIGHT SHALL BE LATERALLY BRACED TO THE STRUCTURE. SUCH BRACING SHALL BE INDEPENDENT OF ANY CEILING LATERAL FORCE BRACING.
- POWER ACTUATED FASTENERS IN CONCRETE OR STEEL SHALL NOT BE USED FOR SUSTAINED TENSION LOADS OR FOR BRACE APPLICATIONS IN SEISMIC DESIGN CATEGORIES D, E, OR F UNLESS APPROVED FOR SEISMIC LOADING. POWER ACTUATED FASTENERS IN MASONRY ARE NOT PERMITTED UNLESS APPROVED FOR SEISMIC LOADING.

A. EXCEPTIONS:

- POWER ACTUATED FASTENERS IN CONCRETE USED FOR SUPPORT OF ACOUSTICAL TILE OR LAY-IN PANEL SUSPENDED CEILING APPLICATIONS AND DISTRIBUTION SYSTEMS WHERE THE SERVICE LOAD ON ANY INDIVIDUAL FASTENER DOES NOT EXCEED 90 LB (40N).
- POWER ACTUATED FASTENERS IN STEEL WHERE THE SERVICE LOAD ON ANY INDIVIDUAL FASTENER DOES NOT EXCEED 250 LB (1,12N).

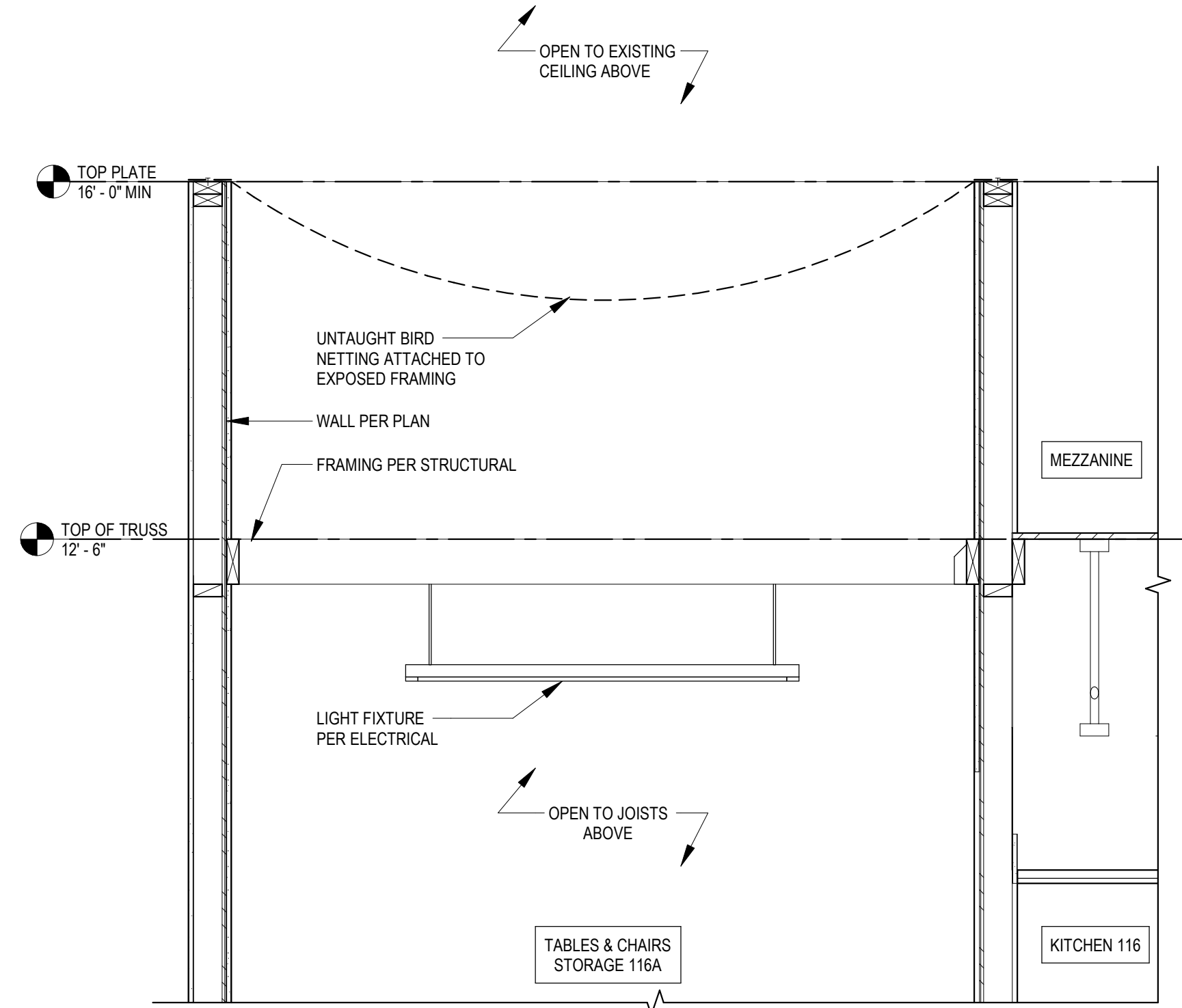

10 BIRD NETTING @ MEZZANINE
3/4" = 1'-0"

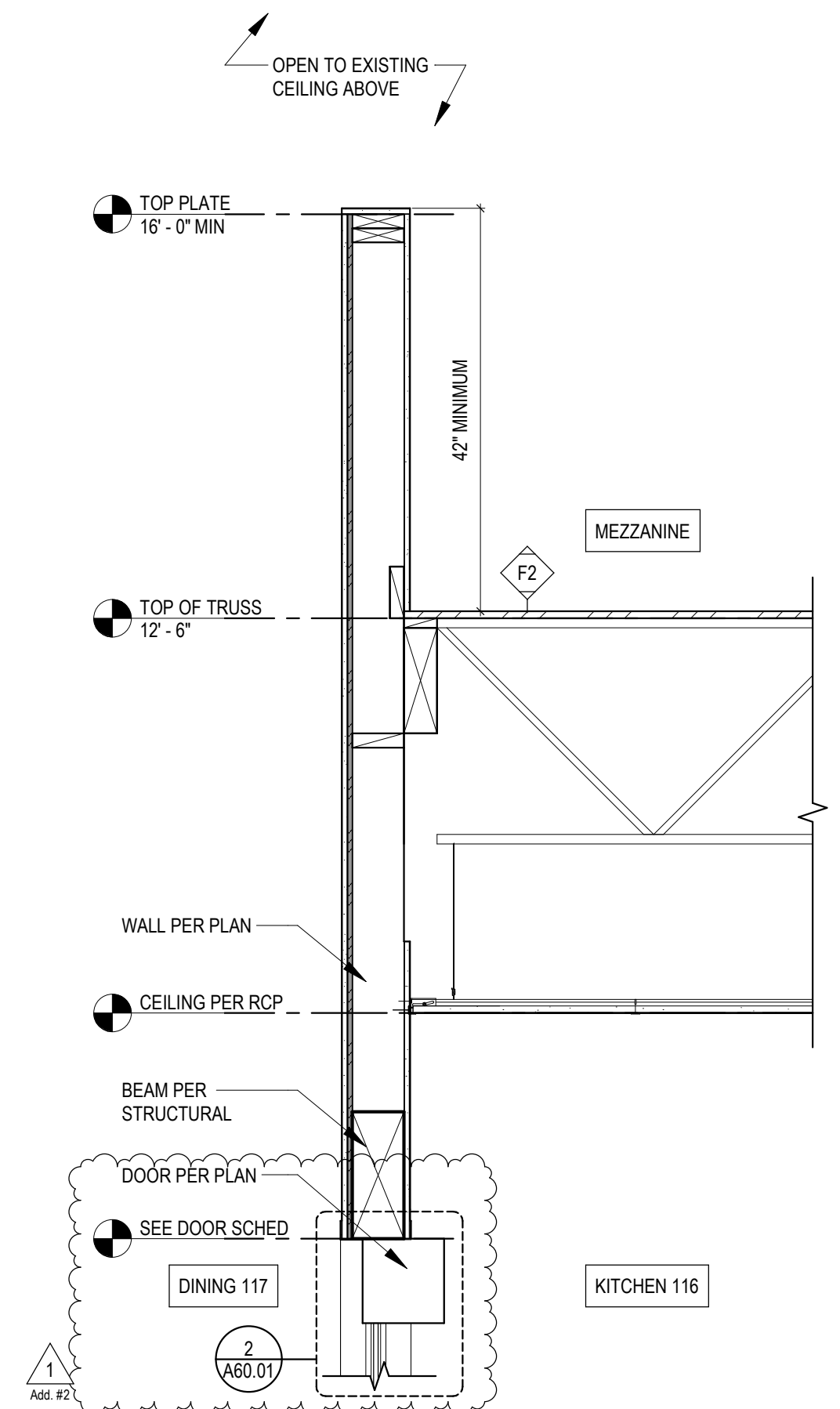

6 KITCHEN MEZZANINE
3/4" = 1'-0"

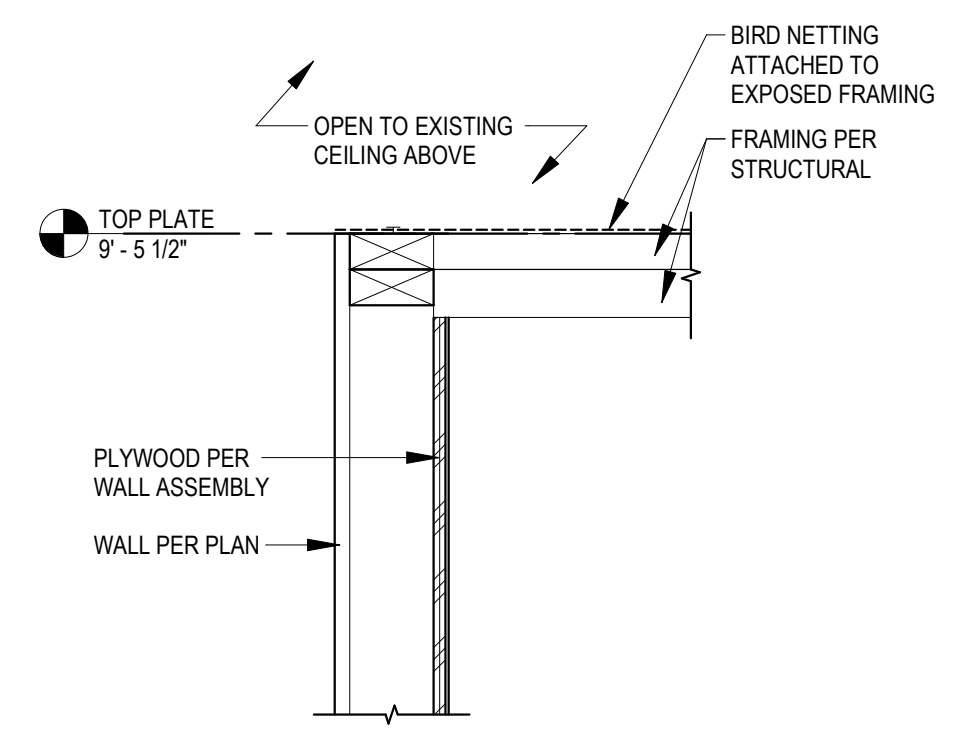

9 STORAGE BIRD NETTING
1 1/2" = 1'-0"

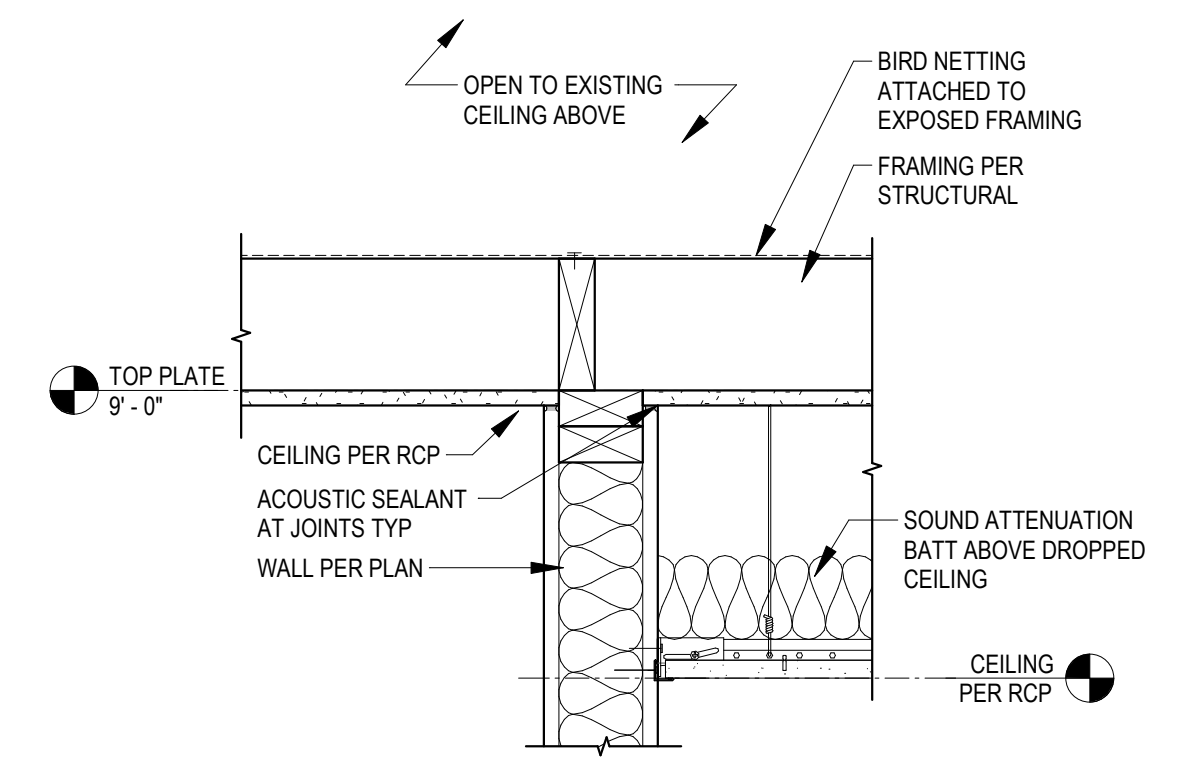

5 KENNELS CEILING
1 1/2" = 1'-0"

1 ACT - SEISMIC BRACING DETAIL
NOT TO SCALE

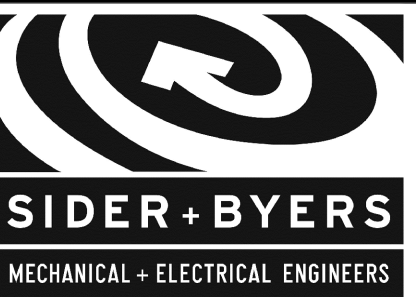

192 Nickerson, Suite #300
Seattle, Washington 98109
Phone: 206.285.2966

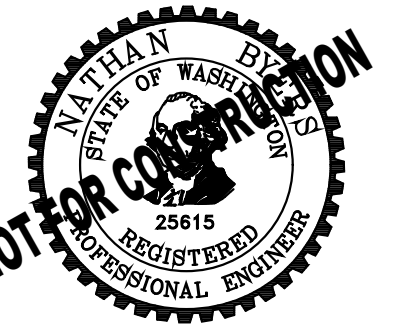

PACIFIC BUILDING CONVERSION
KITSAP COUNTY HUMAN SERVICES DEPARTMENT
4459 SE MILE HILL DRIVE
PORT ORCHARD, WA 98366

PROJECT # 21082

ADDENDUM #2

ISSUE DATE OCTOBER 23, 2023

REVISION SCHEDULE		
1	ADDENDUM #2	11/28/2023

AHJ APPROVAL STAMP

SCHEDULES

SHEET #

M00.04

ENERGY RECOVERY VENTILATOR SCHEDULE

MARK	SERVES	TYPE	MAKE	MODEL	SUPPLY		EXHAUST		HEAT RECOVERY EFFICIENCY	COOLING CAPACITY	EER	HEATING CAPACITY	HSPF	COIL KW	ELECTRICAL			WT. LBS	NOISE LEVEL	NOTES
					CFM	ESP	CFM	ESP							MCA	MOCP	VOLT/PH			
HVAC-1	WEST BEDS	HEATING AND COOLING ERV	GREENHECK	RVE-40-36D	2,400	1	2,400	0.8	70% SENSIBLE MIN 65% LATENT	92.6 TC / 71.8 SC	11.9	49 MBH AT 24F	9	10	74	80	208 / 3	3500	75 DBA	ALL
HVAC-2	EAST BEDS	HEATING AND COOLING ERV	GREENHECK	RVE-40-36D	3,000	1	3,000	0.8	64% SENSIBLE MIN 60% LATENT	95.3 TC/81.4 SC	11.9	50 MBH AT 24F	9	16	101.3	120	208 / 3	3500	75 DBA	ALL
HVAC-3	NORTHEAST BEDS	HEATING AND COOLING ERV	GREENHECK	RVE-40-36D	2,000	1	2,000	0.8	71% SENSIBLE MIN 66% LATENT	71.9 TC/52.3 SC	11.9	38 MBH AT 24F	9	10	62	70	208 / 3	3500	75 DBA	ALL
HVAC-4	DINING AREA	HEATING AND COOLING ERV	GREENHECK	RVE-85-52C	5,000	1	5,000	0.8	74% SENSIBLE MIN 70% LATENT	192.7 TC/147.6 SC	11.9	107 MBH AT 24F	9	25	172	200	208 / 3	5000	75 DBA	ALL

NOTES:

- 1. PROVIDE WITH MASON RSC SPRING CURB
- 2. PROVIDE WITH REMOTE MOUNTED UNIT DISPLAY
- 3. VERTICAL DISCHARGE CONFIGURATION
- 4. OUTSIDE AND EXHAUST AIR HOODS
- 6. MOTORIZED LOW-LEAKAGE DAMPERS FOR SUPPLY AND EXHAUST
- 7. DOUBLE WALL CONSTRUCTION W/ INSULATION
- 9. HINGED ACCESS DOORS
- 10. ECONOMIZER CYCLE WITH START/STOP WHEEL

A. LOW-VOLTAGE THERMOSTAT (SET TO 70F ADJ.) PER SPEC SECTION 230900. PROVIDE WITH REMOTE TEMPERATURE SENSOR

SPLIT SYSTEM HEAT PUMP SCHEDULE

INDOOR UNIT														OUTDOOR UNIT										NOTES			
MARK	MAKE	MODEL	SUPPLY		COOLING			HEATING		ELECTRICAL		SOUND PRESS dBA	OP. WT. LBS.	MARK	MAKE	MODEL	COOLING		HEATING			ELECTRICAL			SOUND PRESS dbA	OP. WT. LBS.	
			TOTAL CFM	ESP W.C.	TOTAL MBH	SENS MBH	EAT DB / WB	OAT DB	HEATING MBH OUTPUT @ 24F OAT	VOLT/PH	MCA						TOTAL MBH	SEER	HEATING HSPF AT 47 F	VOLT / PH	MCA	MOCP					
HP-1A	TRANE/MITSUBISHI	TPLFYP036EM140B	1095	N/A	36.0	30.7	75/63	85	40.0	208 / 230V, 1 PH	0.9	41	60	CU-1	TRANE/MITSUBISHI	TUMYP0601AK43NA	60	17.8	10.7	208/230V / 1	36	45	59	310	1, C		
HP-1B	TRANE/MITSUBISHI	TPLFYP036EM140B	1095	N/A	36.0	30.7	75/63	85	40.0	208 / 230V, 1 PH	0.9	41	60												4, A		
																									4, A		

NOTES:

- 1. MANUFACTURER'S DIGITAL CONTROL SYSTEM WITH TE-200A CENTRAL CONTROLLER.
- 2. CONTROL POWER SUPPLY UNIT.
- 3. FACTORY FILTER BOX WITH MERV 8 FILTER.
- 4. RESILIANIT RUBBER MOUNTING AT ALL FAN COIL UNITS INCLUDING WALL MOUNT UNITS.

- A. MANUFACTURER'S WIRING INTERFACE AND THERMOSTAT
- B. PROVIDE WITH BLUE DIAMOND CONDENSATE PUMP
- C. D/DO BOARD FOR HVAC & RTU UNITS ON/OFF CONTROL AND ALARM

ROOFTOP HEAT PUMP UNIT SCHEDULE

MARK	MAKE	MODEL	LOCATION	FAN			COOLING						HEATING				ELECTRICAL				SOUND DBA	WT. LBS.	NOTES		
				SUPPLY AIR		RETURN AIR	OSA	TOTAL	SENS.	EAT	OAT	EER	SEER	OUTPUT MBH @ 17 OAT	ELEC STAGES	HEATER KW	HSPF	COP AT 17F	VOLTAGE / PHASE	MCA				SCCR (kA)	
				CFM	ESP	CFM	ESP	CFM	MBH	MBH	DB/WB	DB													
RTU-1	TRANE	WHC036H3RB	ROOF	1200	0.5	1000	0.5	200	39.1	29.4	80/67	85	12.5	16.0	17.4	1	4.5	8.8	3.6	208 / 3	39.0	NOTE A	81	800	ALL

NOTES:

- 1. MATCH ROOF SLOPE
- 2. ECONOMIZER
- 3. MERV 13 SUPPLY AIR & MERV 8 RETURN AIR FILTERS
- 4. SINGLE POINT POWER CONNECTION
- 5. R410A
- 6. MANUFACTURER'S 7-DAY PROGRAMMABLE 2C/2H THERMOSTAT
- 7. DOWNFLOW SUPPLY & RETURN
- A. PROVIDE RATING PER SPECIFICATIONS AND ELECTRICAL

FLAG NOTES

- ① DUCTWORK THRU EX 28" JOISTS, 24" O.C.
- ② 1" DOOR UNDERCUT
- ③ 24X12 LINED SHEET METAL TRANSFER DUCT HIGH OVER DOOR WITH 2. RG-13 GRILLES
- ④ 24X24 DOOR LOUVER AT +12 AFF
- ⑤ 1" UNDERCUT AT DOOR
- ⑥ EG-1 125
- ⑦ 14"Ø THRU TRUSSES (TYP 2)
- ⑧ PROVIDE FLEX CONNECTION AT SUPPLY AND RETURN

HVAC SCOPE OF WORK

- 1. REPLACE EXISTING GAS UNITS WITH HEAT PUMPS. NEW DUCTWORK AND CONTROLS IN ADMIN, TRAINING, AND RECEPTION.
- 2. REMOVE EXISTING ROOFTOP UNITS, DUCTWORK AND CONTROLS. REMOVE EXHAUST FANS SERVING TOILET ROOMS.
- 3. PROVIDE 100% OSA / 100% EXHAUST ROOFTOP UNITS WITH HEAT RECOVERY WHERE SHOWN.
- 4. EXPOSED DUCTWORK AND GRILLES IN ROOMS 113, 114, 117, 126, 127, AND 131.
- 5. SEVEN DAY PROGRAMMABLE THERMOSTATS WITH REMOTE SENSORS FOR CONTROL. THERMOSTATS MUST BE IN LOCATIONS THAT ARE NOT AVAILABLE TO THE RESIDENTS.
- 6. DRYER VENT AND MAKEUP AIR.
- 7. EXHAUST FOR ALL RESIDENT TOILET ROOMS WILL BE DONE THROUGH THE NEW ROOFTOP ERV'S.

ricefergusmiller
 ARCHITECTURE INTERIORS PLANNING VIZLAB
 275 FIFTH STREET, SUITE 100
 BREMERTON, WA 98337
 360-377-8773
 RFMARCH.COM

SIDER+BYERS
 MECHANICAL • ELECTRICAL ENGINEERS
 192 Nickerson, Suite #300
 Seattle, Washington 98109
 Phone: 206.285.2966

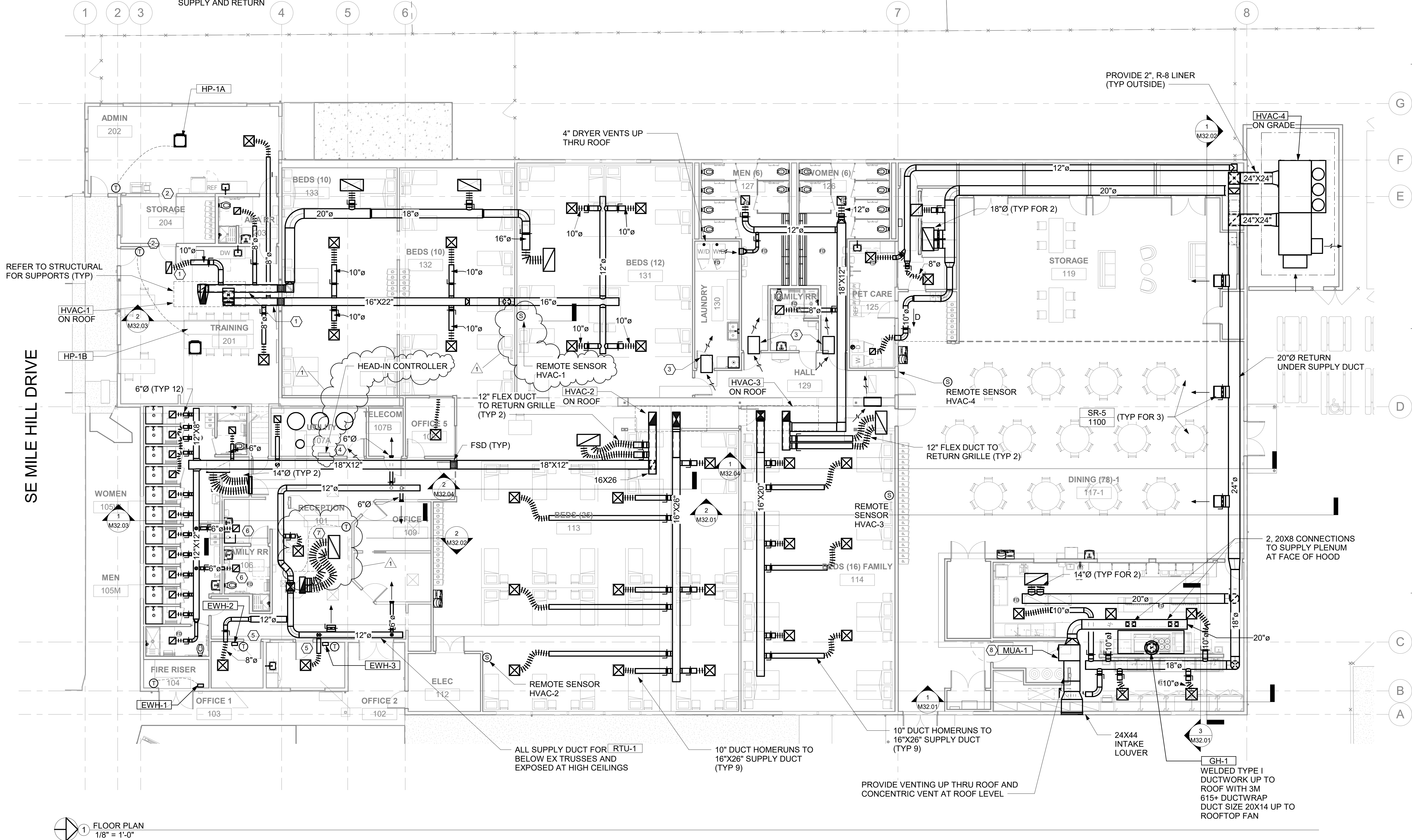

SE MILE HILL DRIVE

FLOOR PLAN
 1/8" = 1'-0"

PACIFIC BUILDING CONVERSION
 KITSAP COUNTY HUMAN SERVICES DEPARTMENT
 4459 SE MILE HILL DRIVE
 PORT ORCHARD, WA 98366

PROJECT #	21082
ADDENDUM #2	
ISSUE DATE	NOVEMBER 29, 2023
REVISION SCHEDULE	
1	ADDENDUM #2 11/29/2023

AHJ APPROVAL STAMP	
--------------------	--

FLOOR PLAN

SHEET #

M22.01

DATE/TIME PRINTED: 11/29/2023 2:07:40 PM
 C:\Users\kafina\Documents\21082_MECH_CENTRAL_V21_katnashibov.rvt

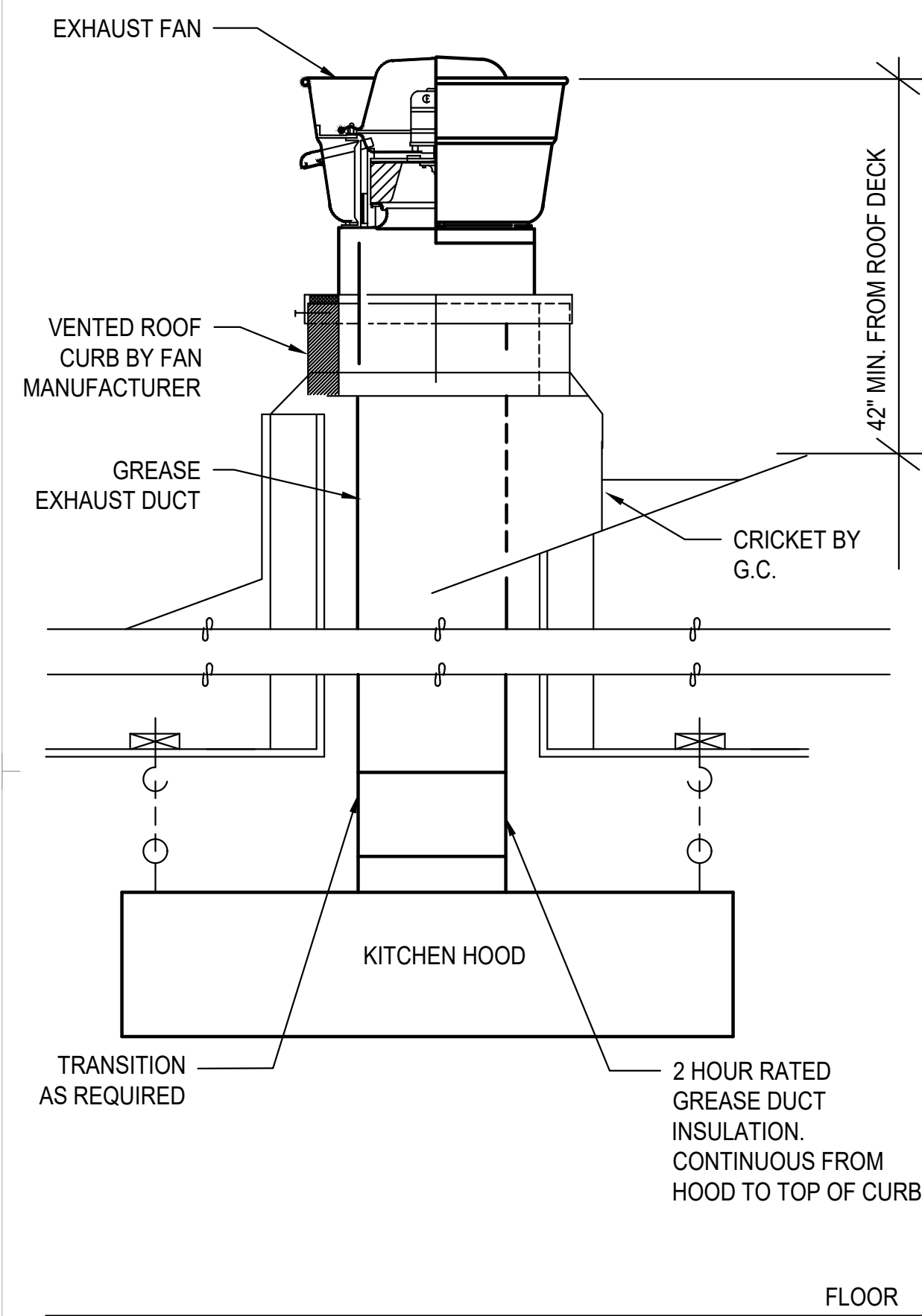

GENERAL NOTES FOR GREASE EXHAUST SYSTEM FOR KITCHEN

1. EXHAUST DUCT SHALL BE CONSTRUCTED OF NOT LESS THAN 0.055 INCH (NO. 16 MANUFACTURER'S STANDARD GAUGE) STEEL OR STAINLESS STEEL NOT LIGHTER THAN (0.044 INCH) NO. 18 MANUFACTURER'S STANDARD GAUGE.
2. ALL EXHAUST DUCT JOINTS AND SEAMS SHALL BE MADE WITH CONTINUOUS LIQUID TIGHT WELD OR BRAZE MADE ON EXTERNAL SURFACE OF THE DUCT SYSTEM. DUCT CONNECTION TO HOOD SHALL BE CONTINUOUS LIQUID-TIGHT WELD OR BRAZE, SMOOTH WITHOUT LEDGE GREASE TRAP.
3. DUCT SYSTEM SHALL BE SO CONSTRUCTED AND INSTALLED THAT GREASE CANNOT BECOME POCKETED IN ANY PORTION THEREOF, AND THE SYSTEM SHALL SLOPE NOT LESS THAN 1/4 INCH PER LINEAR FOOT TOWARDS THE HOOD. WHERE HORIZONTAL DUCTS EXCEED 75 FEET IN LENGTH, THE SLOPE SHALL NOT BE LESS THAN 1 INCH PER LINEAR FOOT.
4. ANY PORTION HAVING SECTIONS INACCESSIBLE FROM THE DUCT ENTRY OR DISCHARGE SHALL BE PROVIDED ADEQUATE CLEANOUT OPENINGS. CLEANOUT OPENINGS SHALL BE EQUIPPED WITH TIGHT FITTING DOORS CONSTRUCTED OF STEEL HAVING A THICKNESS NOT LESS THAN THAT REQUIRED FOR THE DUCT. DOORS SHALL BE EQUIPPED WITH A SUBSTANTIAL METHOD OF LATCHING, SUFFICIENT TO HOLD THE DUCT TIGHTLY CLOSED. CLEANOUTS SHALL BE INSTALLED EVERY 20 FEET AND EVERY CHANGE IN DIRECTION AS A MINIMUM.
5. DUCT SYSTEM SHALL BE CLOSED IN SHAFT CONSTRUCTION AS INDICATED ON ARCHITECTS DRAWINGS. THE DUCT ENCLOSURE SHALL BE SEALED AROUND THE DUCT AT THE POINT OF PENETRATION AND VENTED TO THE EXTERIOR THROUGH CURB. THE ENCLOSURE SHALL BE SEPARATED FROM THE DUCT BY AT LEAST SIX INCHES AND SHALL SERVE SINGLE GREASE EXHAUST DUCT SYSTEM.
6. EXHAUST DUCT SHALL TERMINATE A MINIMUM OF 18 INCHES ABOVE ROOF SURFACE AND TERMINATE WITH A FLANGE AND GASKET AT BASE OF EXHAUST FAN.
7. DUCT SYSTEM SHALL BE SIZED FOR A MINIMUM VELOCITY OF 500 FEET PER MINUTE AND MAXIMUM VELOCITY OF 2500 FEET PER MINUTE.
8. DUCT SYSTEM SHALL NOT CONTAIN FIRE DAMPERS, BALANCING DAMPERS OR TURNING VANES.
9. PRIOR TO DUCT CONCEALMENT PERFORM LIGHT LEAKAGE TEST ON ENTIRE DUCT AND DUCT TO HOOD CONNECTION.
10. UPON SYSTEM COMPLETION PERFORM SMOKE CAPTURE AND CONTAINMENT TEST.

KITCHEN HOOD & EXHAUST FAN DETAIL

1
M33.04 N.T.S.

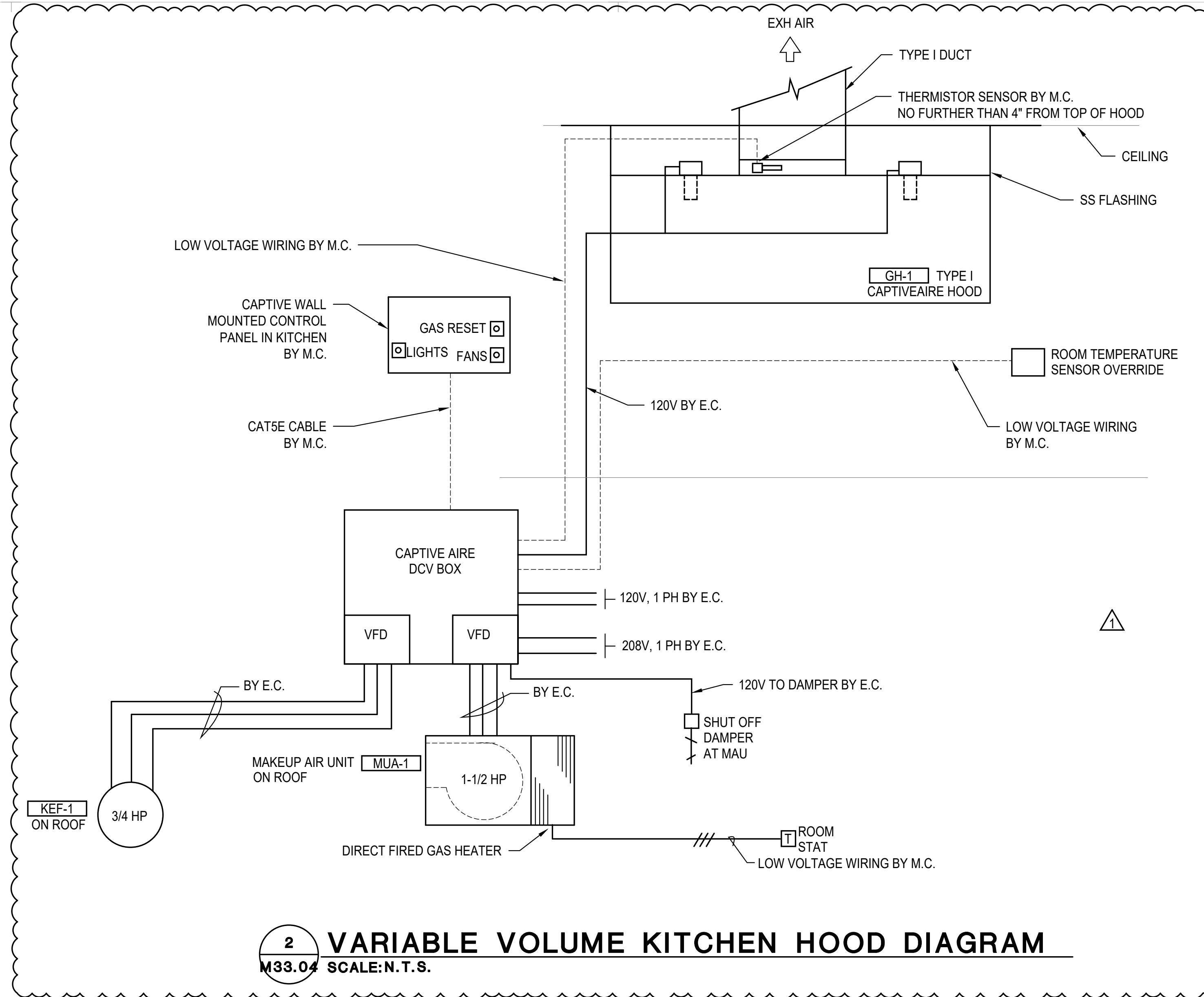

VARIABLE VOLUME KITCHEN HOOD DIAGRAM

2
M33.04 SCALE: N.T.S.

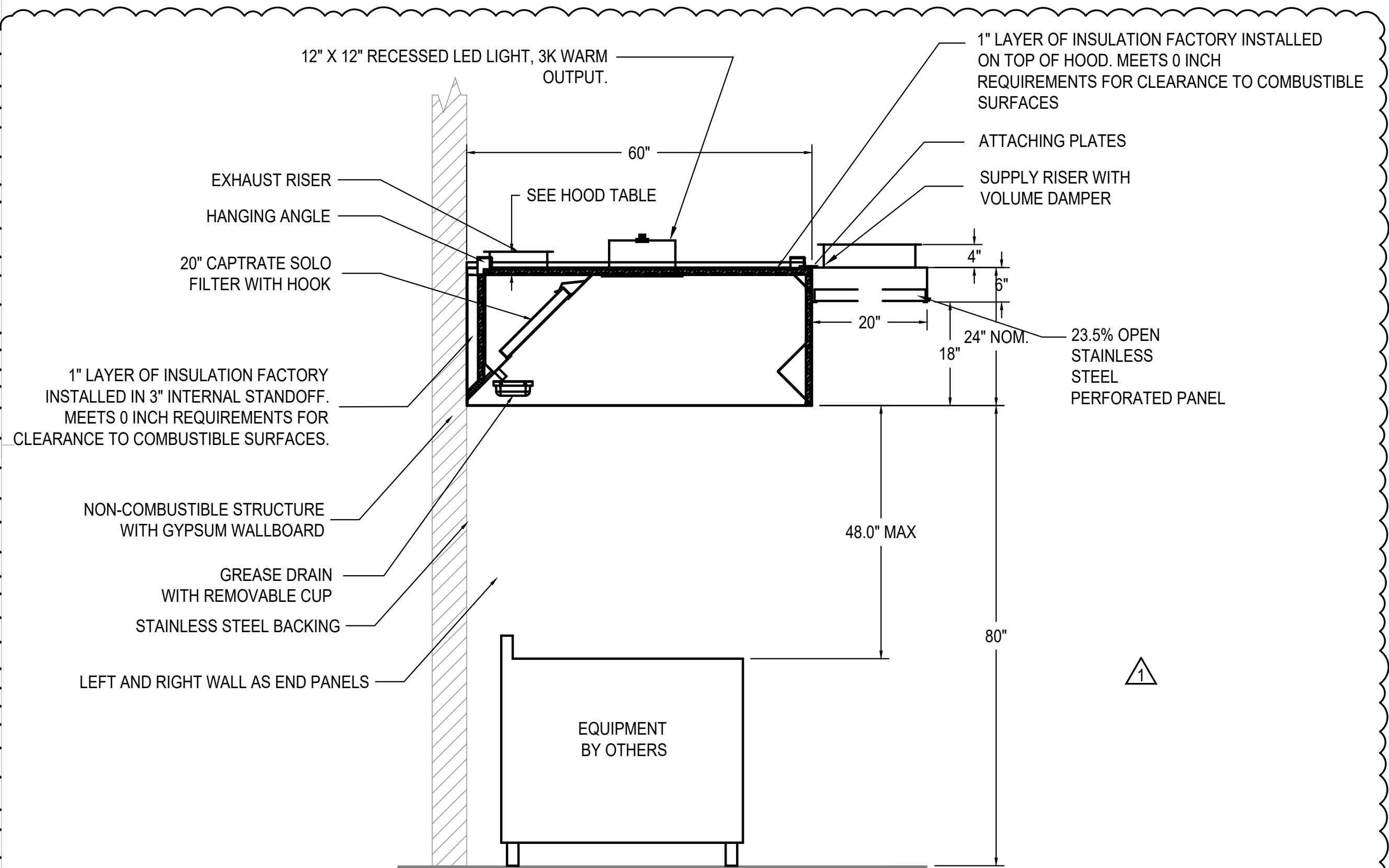

VARIABLE VOLUME KITCHEN HOOD SECTION

3
M33.04 SCALE: N.T.S.

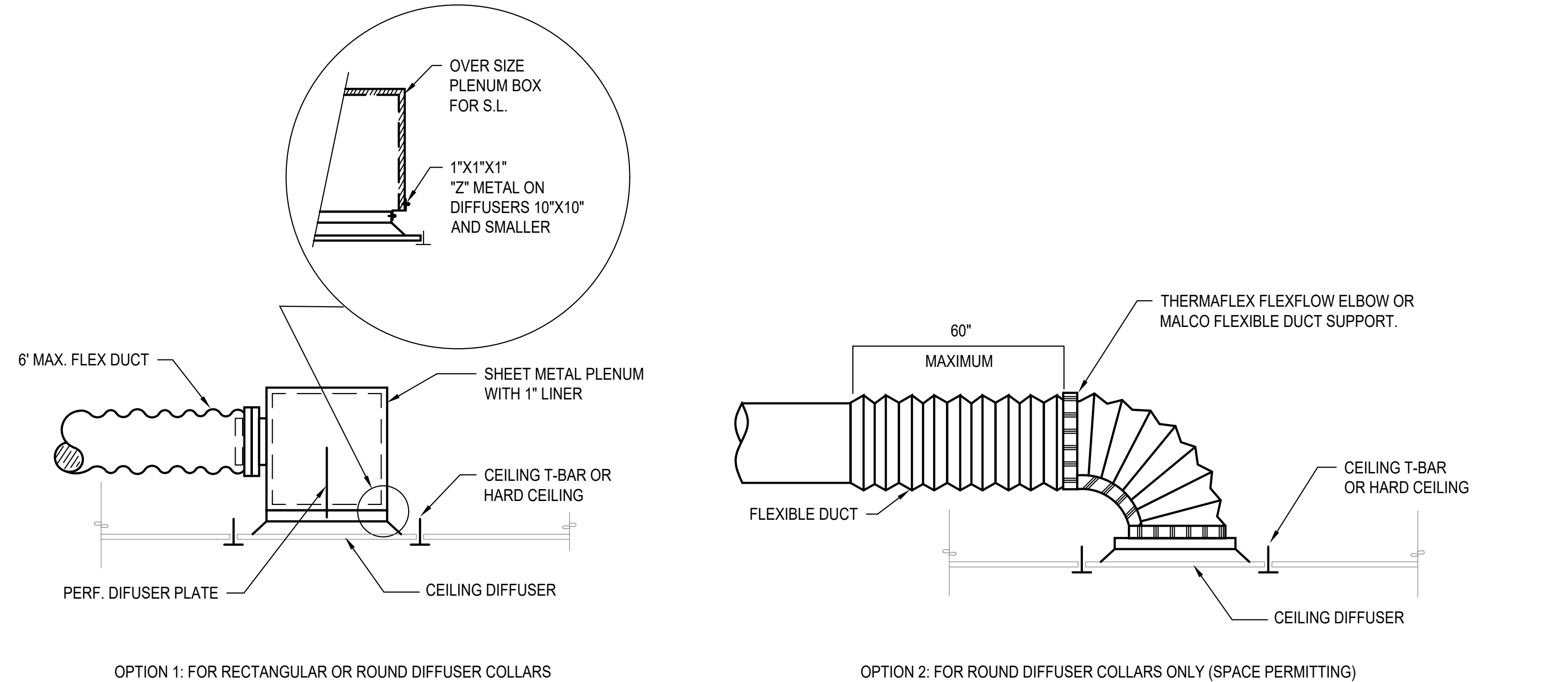

TYPICAL DIFFUSER DETAIL CEILING INSTALLATION

4
M33.04 Scale: NONE

- NOTES:
1. SEE ARCHITECTURAL PLANS FOR CEILING TYPES.
 2. SUPPLY SHOWN, DETAIL WITHOUT PERF PLATE IS TYPICAL FOR CEILING RETURN OR EXHAUST GRILLE INSTALLATION.



PROJECT # 21082

ADDENDUM #2

ISSUE DATE NOVEMBER 29, 2023

REVISION SCHEDULE		
NO.	DESCRIPTION	DATE
1	ADDENDUM #2	11/29/2023

AHJ APPROVAL STAMP



SIDER + BYERS
MECHANICAL - ELECTRICAL ENGINEERS

192 Nickerson, Suite #300
Seattle, Washington 98109
Phone: 206.285.2966



**CITY MULTI
SYSTEM SCHEMATIC DWG.**

This drawing is schematic in nature. Final routing of piping & wiring shall be determined by the installing contractor and/or designer of record. Additional refrigerant charge is needed depending on the size and length of extended piping. Please refer the amount of pre-charge and the formula of calculation which is mentioned on the data book.

1.25mm²(16 AWG) : 1.25mm²(16 AWG) or more. 0.75mm²(20 AWG) : between 0.5mm²(24 AWG) and 0.75mm²(20 AWG).

DIAGRAM SYMBOL LEGEND		CONT.No	PAGE
---	POWER WIRE		
---	CONTROL WIRE		
---	REF. PIPE		

PIPING AND CONTROLS	
SYMBOL	BRANCH PIPE MODEL NAME
J1	CMY-Y62-G-E
SYMBOL	LIQUID PIPE/GAS PIPE SIZE
P1	3/8 / 3/4
P2	3/8 / 5/8
SYMBOL	MODEL NUMBER
WA/WR	TAR-FL32MA-E

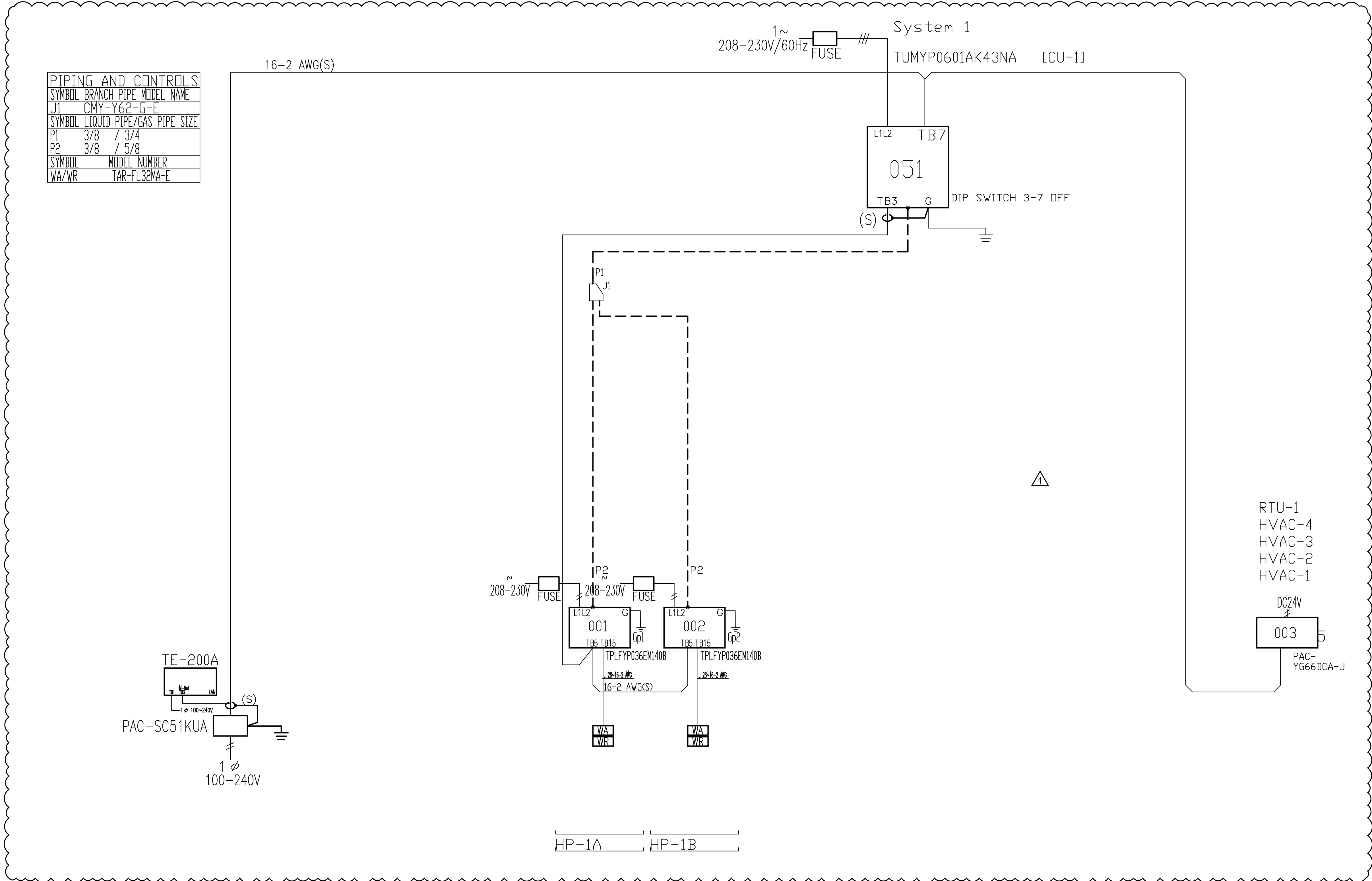

PACIFIC BUILDING CONVERSION
KITSAP COUNTY HUMAN SERVICES DEPARTMENT
4459 SE MILE HILL DRIVE
PORT ORCHARD, WA 98366

PROJECT # 21082

ADDENDUM #2

ISSUE DATE OCTOBER 23, 2023

REVISION SCHEDULE		
1	ADDENDUM #2	11/28/2023



CITY MULTI DIAGRAM

SHEET #

M42.00



SIDER+BYERS
MECHANICAL + ELECTRICAL ENGINEERS

192 Nickerson, Suite #300
Seattle, Washington 98109
Phone: 206.285.2966

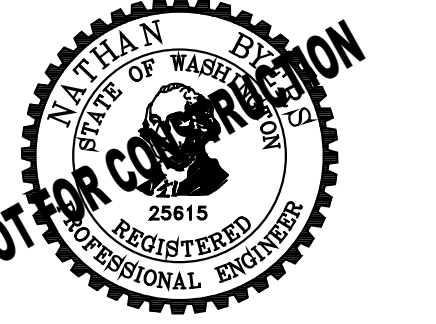

PACIFIC BUILDING CONVERSION
KITSAP COUNTY HUMAN SERVICES DEPARTMENT
4459 SE MILE HILL DRIVE
PORT ORCHARD, WA 98366

PROJECT # 21082

ADDENDUM #2

ISSUE DATE OCTOBER 23, 2023

REVISION SCHEDULE		
1	ADDENDUM #2	11/28/2023



FLOOR PLAN -
FOUNDATION

SHEET #

P22.00

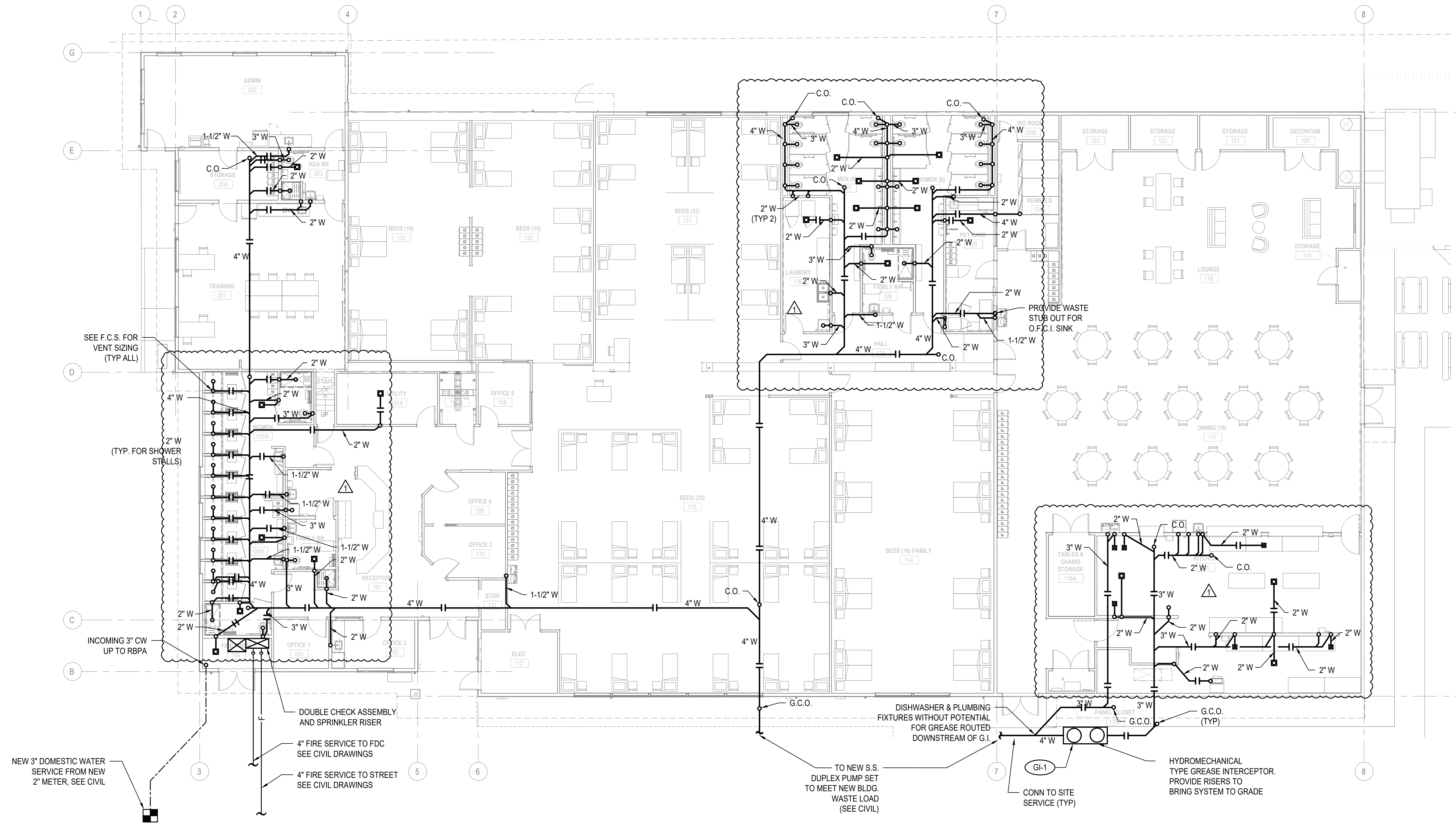

FLOOR PLAN - FOUNDATION
SCALE: 1/8"=1'-0"

DATE/TIME PRINTED: 10/20/2023 2:27:38 PM
20230901 Pacific Building Conversion - 2023.dwg

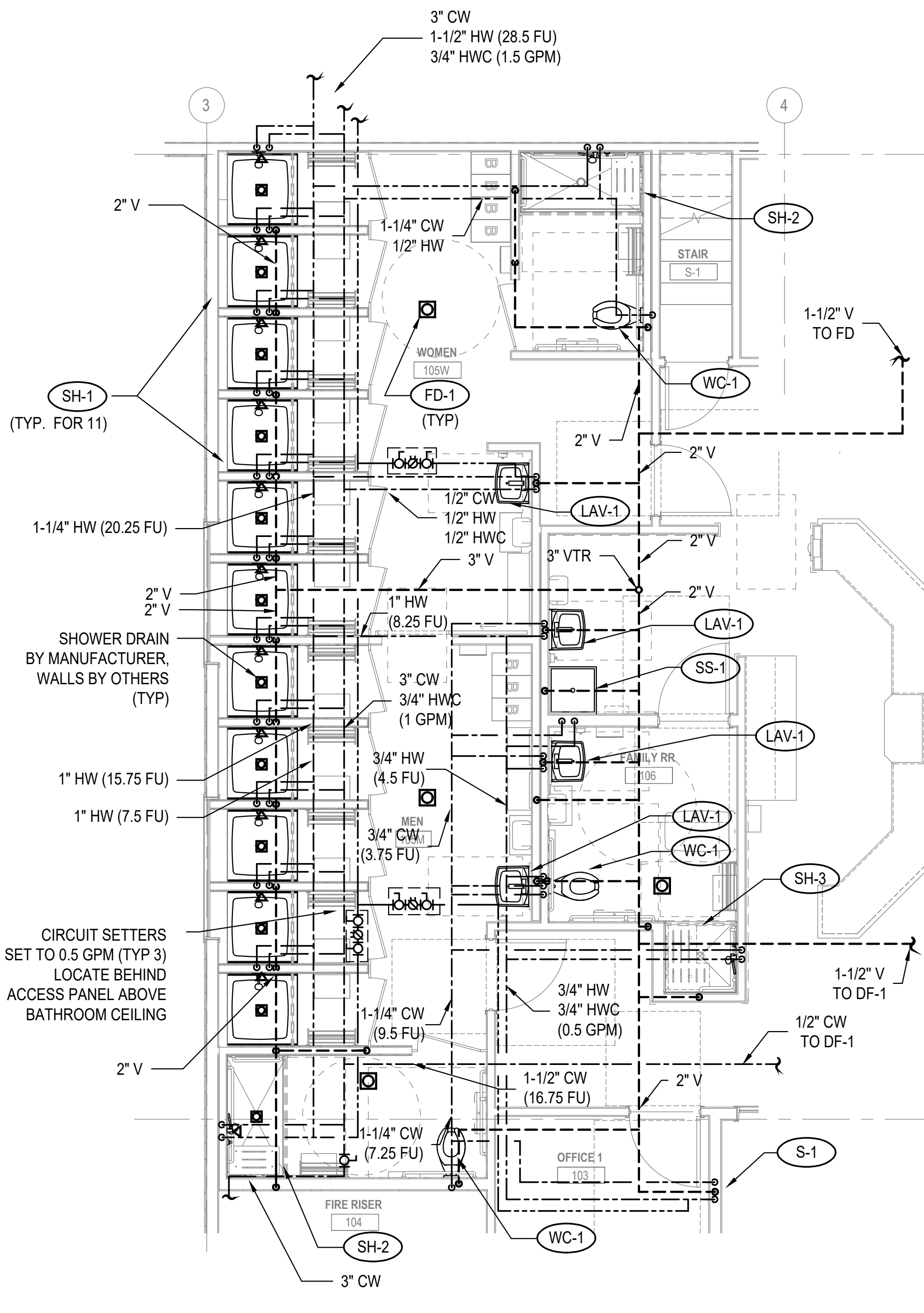

ENLARGED FLOOR PLAN SHOWER ROOMS

1
P23.01 1/4"=1'-0"

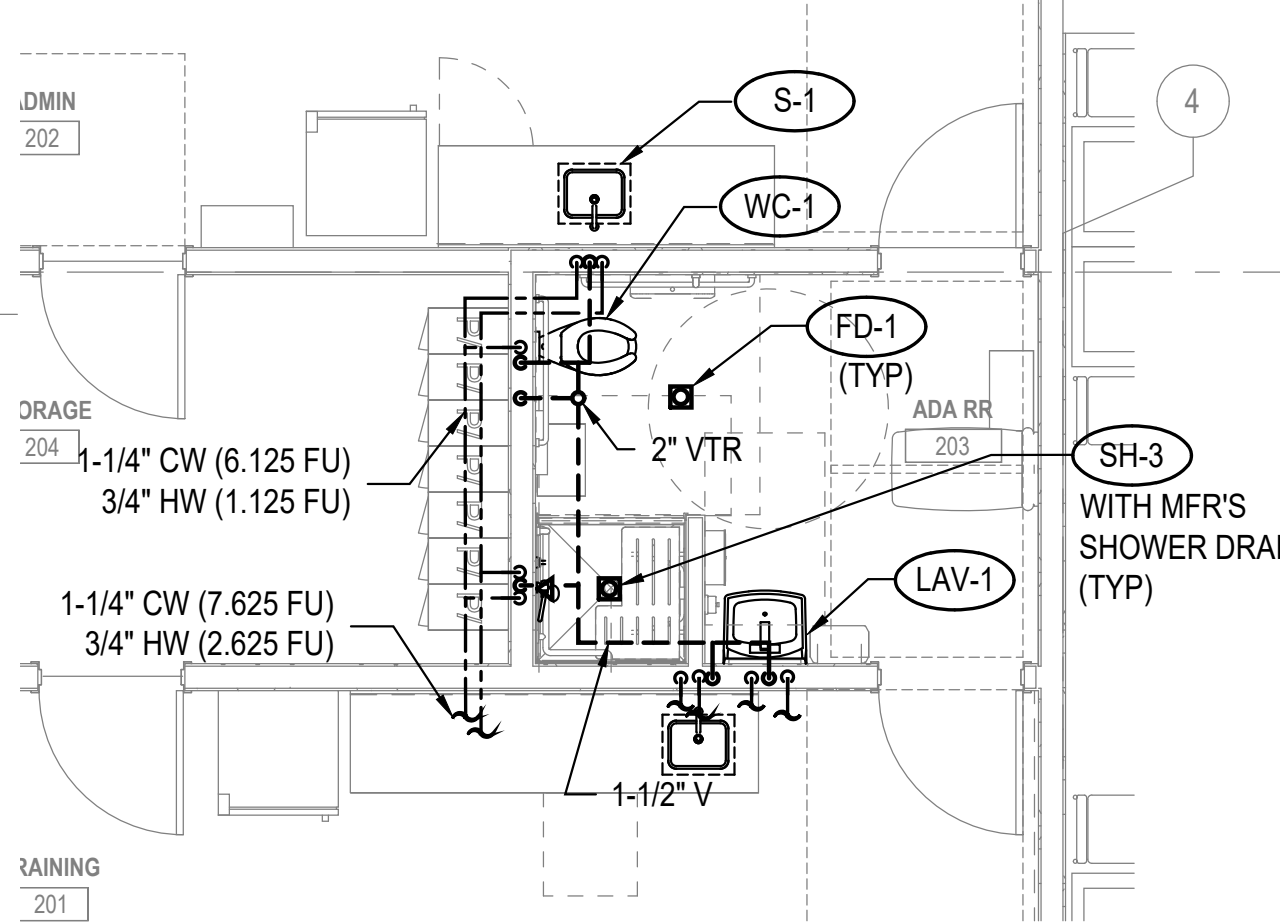

ENLARGED FLOOR PLAN SINGLE RESTROOM

2
P23.01 1/4"=1'-0"

VENTING UPDATED TO MATCH P22.00 WASTE ROUTING.
FLOOR SINKS ADDED TO KITCHEN

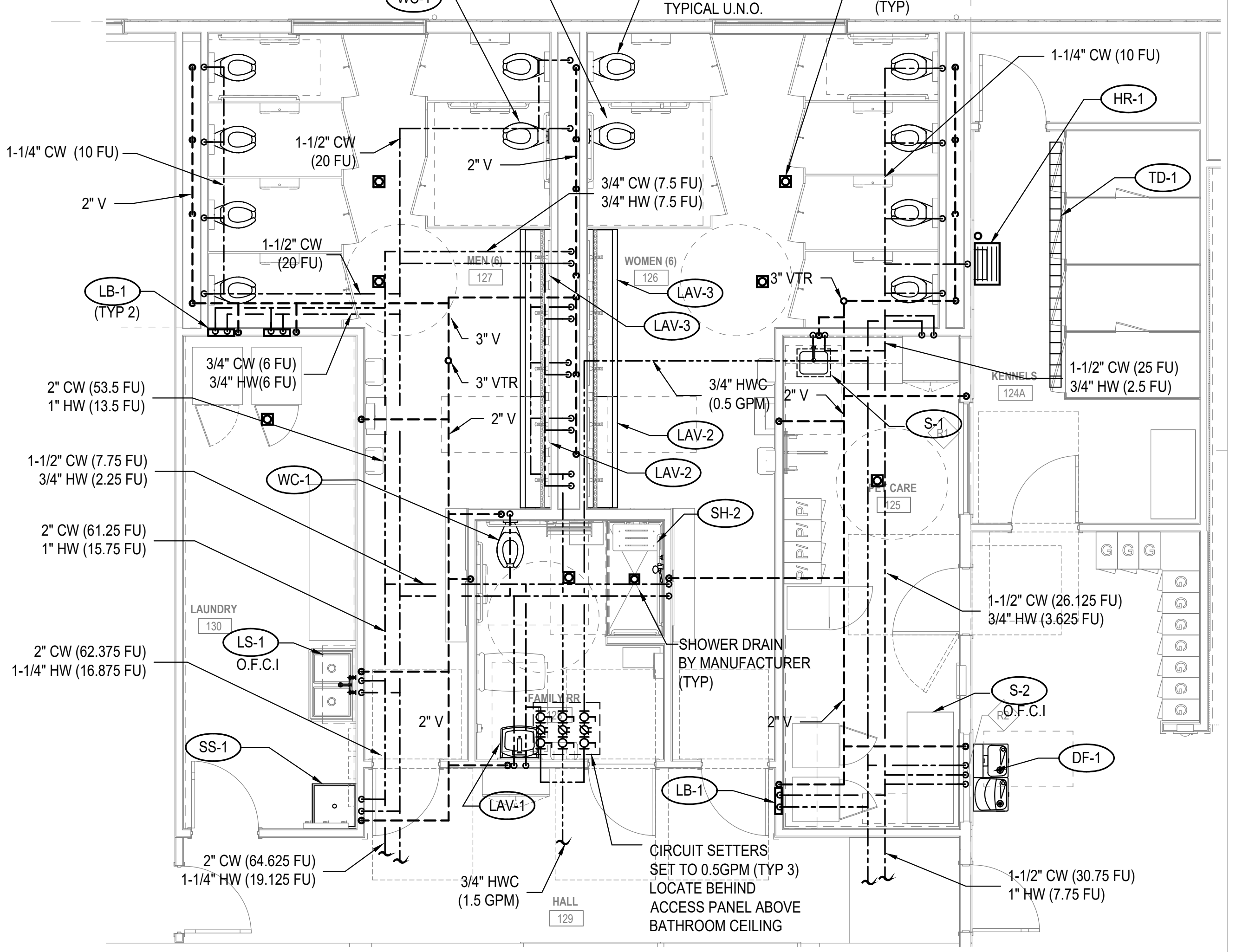

ENLARGED FLOOR PLAN TOILET ROOMS

3
P23.01 1/4"=1'-0"

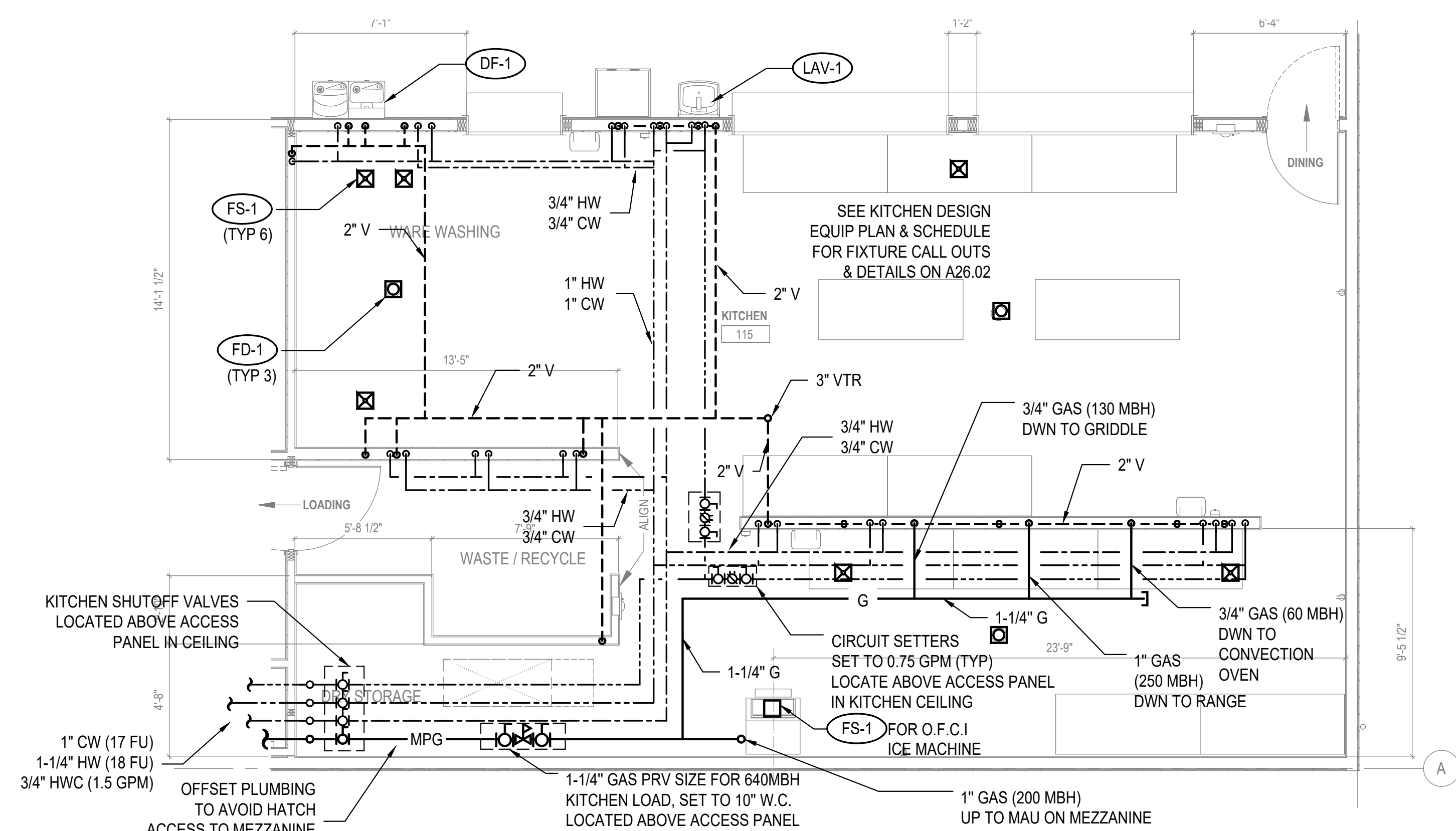

ENLARGED FLOOR PLAN - KITCHEN

4
P23.01 1/4"=1'-0"

DATE/TIME PRINTED: 10/20/2022 2:27:38 PM
20210501 Pacific Building Conversion - 2021.dwg.rvt

RICEfergusMILLER
ARCHITECTURE INTERIORS PLANNING VIZLAB
275 FIFTH STREET, SUITE 100
BREMERTON, WA 98337
360-377-8773
RFMARCH.COM

SIDER+BYERS
MECHANICAL - ELECTRICAL ENGINEERS
192 Nickerson, Suite #300
Seattle, Washington 98109
Phone: 206.285.2966

NOT FOR CONSTRUCTION
REGISTERED PROFESSIONAL ENGINEER
56515
STATE OF WASHINGTON

PACIFIC BUILDING CONVERSION
KITSAP COUNTY HUMAN SERVICES DEPARTMENT

4459 SE MILE HILL DRIVE
PORT ORCHARD, WA 98366

PROJECT # 21082
ADDENDUM #2
ISSUE DATE OCTOBER 23, 2023

REVISION SCHEDULE		
NO.	DESCRIPTION	DATE
1	ADDENDUM #2	11/28/2023

AHJ APPROVAL STAMP

SHEET #

GENERAL NOTES:

1. PROVIDE CONTROLLED RECEPTACLES IN ALL AREAS AS REQUIRED BY WECC.
2. TELEPHONE AND TELEVISION SERVICES TO BE EXTENDED TO NEW IT ROOM 107B. PROVIDE PLYWOOD BACKING AS REQUIRED BY COUNTY OR LOW VOLTAGE VENDOR.
3. ALL LOW VOLTAGE CABLING, DEVICES, EQUIPMENT FOR TELEPHONE/DATA/SECURITY/VIDEO AND TELEVISION SYSTEMS TO BE BY COUNTY SUBCONTRACTOR.
4. PROVIDE FIRE ALARM DEVICES AS REQUIRED BY CODE. CONTROL PANEL TO NEW STANDBY PANEL 'SB'.
5. CONNECT NEW HVAC EQUIPMENT TO NEW STANDBY PANEL 'SB'.
6. CONNECT NEW WATER HEATERS TO NEW STANDBY PANEL 'SB'.
7. CONNECT ALL FREEZERS AND REFRIGERATORS TO NEW STANDBY PANEL 'SB'. PROVIDE ROUGH-IN FOR FUTURE REFRIGERATION EQUIPMENT.
8. PROVIDE 1 1/2" CONDUIT ONLY TO ROOF AND CAP FOR FUTURE PV SYSTEM PER WECC.
9. ALL RECEPTACLES IN COMMON AREAS SHALL BE TAMPER-RESISTANT UNLESS NOTED OTHERWISE.
10. EXISTING FIRE ALARM SYSTEM TO BE REPLACED. REUSE EXISTING FIRE ALARM CONDUITS AND O-BOXES WHERE APPROVED. FIRE ALARM SYSTEM TO CONFORM TO CURRENT NFPA AND LOCAL CODES. SUBMIT FULLY ENGINEERED DRAWINGS TO PORT ORCHARD FIRE DEPARTMENT FOR REVIEW AND APPROVAL.
11. RE-USE EXISTING BRANCH CIRCUITRY AND HOMERUNS TO PANELS WHERE POSSIBLE.
12. MOUNT PLUG STRIP BELOW COUNTER. CUT AND PATCH FLOORING TO RUN CIRCUITRY TO NEAREST OUTLET.
13. EXISTING DEVICES AND CIRCUITRY SHOWN IS DIAGRAMMATIC. CONTRACTOR TO FIELD VERIFY ALL EXISTING DEVICE LOCATIONS AND BRANCH CIRCUITRY AND MAKE ADJUSTMENTS AT NO ADDITIONAL COST.
14. EXISTING BRANCH CIRCUITRY TO REMAIN SHALL MEET CURRENT CODES. MODIFY AS REQUIRED.
15. COORDINATE ALL INFORMATION MANAGEMENT OUTLETS (IMO) CONFIGURATIONS AND LOCATIONS WITH OWNER.

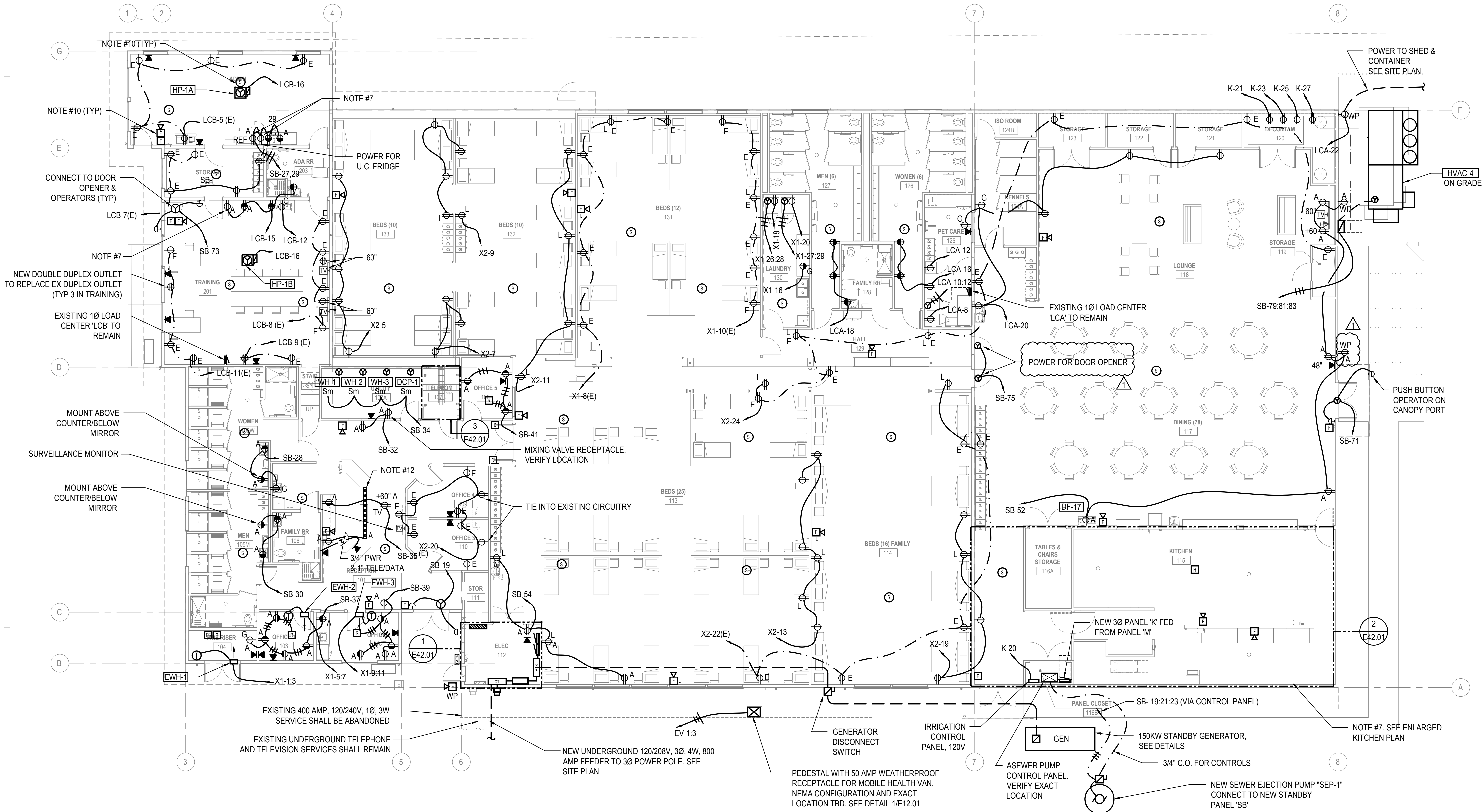

FLOOR PLAN - POWER
SCALE: 1/8" = 1'-0"



PACIFIC BUILDING CONVERSION
KITSAP COUNTY HUMAN SERVICES DEPARTMENT
4459 SE MILE HILL DRIVE
PORT ORCHARD, WA 98366

PROJECT # 21082
BID SET
ISSUE DATE OCTOBER 23, 2023

REVISION SCHEDULE		
NO.	ADDENDUM #2	DATE
1		11/29/2023
2		

AHJ APPROVAL STAMP

FLOOR PLAN - POWER

GENERAL NOTES:

- EXISTING FIXTURES TO BE REMOVED, UNLESS NOTED OTHERWISE.
- REPLACE ALL EXIT AND EMERGENCY LIGHTING FIXTURES WITH NEW FIXTURES AS SCHEDULED. PROVIDE ADDITIONAL EXIT AND EMERGENCY LIGHTING FIXTURES TO MEET CODE.
- REPLACE ALL EXISTING LIGHTING FIXTURES IN AREAS OF NEW WORK WITH LED FIXTURES. RETROFIT AUTOMATIC LIGHTING CONTROLS TO MEET 2018 WASHINGTON ENERGY CODE (WEC).
- PROVIDE NEW LED LIGHTING AND DEVICES IN ALL NEW ROOMS AND RECONFIGURED SPACES AS REQUIRED BY OWNER.
- EXTEND UNSWITCHED CONDUCTOR TO EXIT AND EMERGENCY LIGHTING FIXTURES. CONNECT TO LOCAL LIGHTING CIRCUIT.
- SEE POWER PLAN E22.01 FOR LED NIGHT LIGHT RECEPTACLE COVER PLATES.

LIGHTING PLAN KEY NOTES:

- EXISTING LIGHTING FIXTURE, CONTROLS, CIRCUITRY TO REMAIN AS NOTED. RELACE LAMPS IN DOWNLIGHTS WITH LED EQUIVALENT LAMPS.
- REMOVE LIGHT SWITCHES. INSTALL LINE VOLTAGE DIMMERS FOR AREAS WITH DIMMING. INSTALL LOW VOLTAGE LIGHT SWITCHES WHERE DAYLIGHTING CONTROLS ARE REQUIRED PER WEC.
- REMOVE EXISTING LIGHTING CIRCUITS AND ROUTE CIRCUITRY TO PANEL "SB" AS INDICATED.
- EXISTING FIXTURES AND CONTROLS TO REMAIN.
- EXIT LIGHT FIXTURES TO BE ON CIRCUIT SB-26. EMERGENCY LIGHTING FIXTURES TO BE FED FROM ROOM LIGHTING CIRCUIT.
- TO SWITCH BANK.
- REMOVE SWITCHES
- TIE STEP LIGHTS INTO EXISTING CANOPY LIGHTING CIRCUIT.

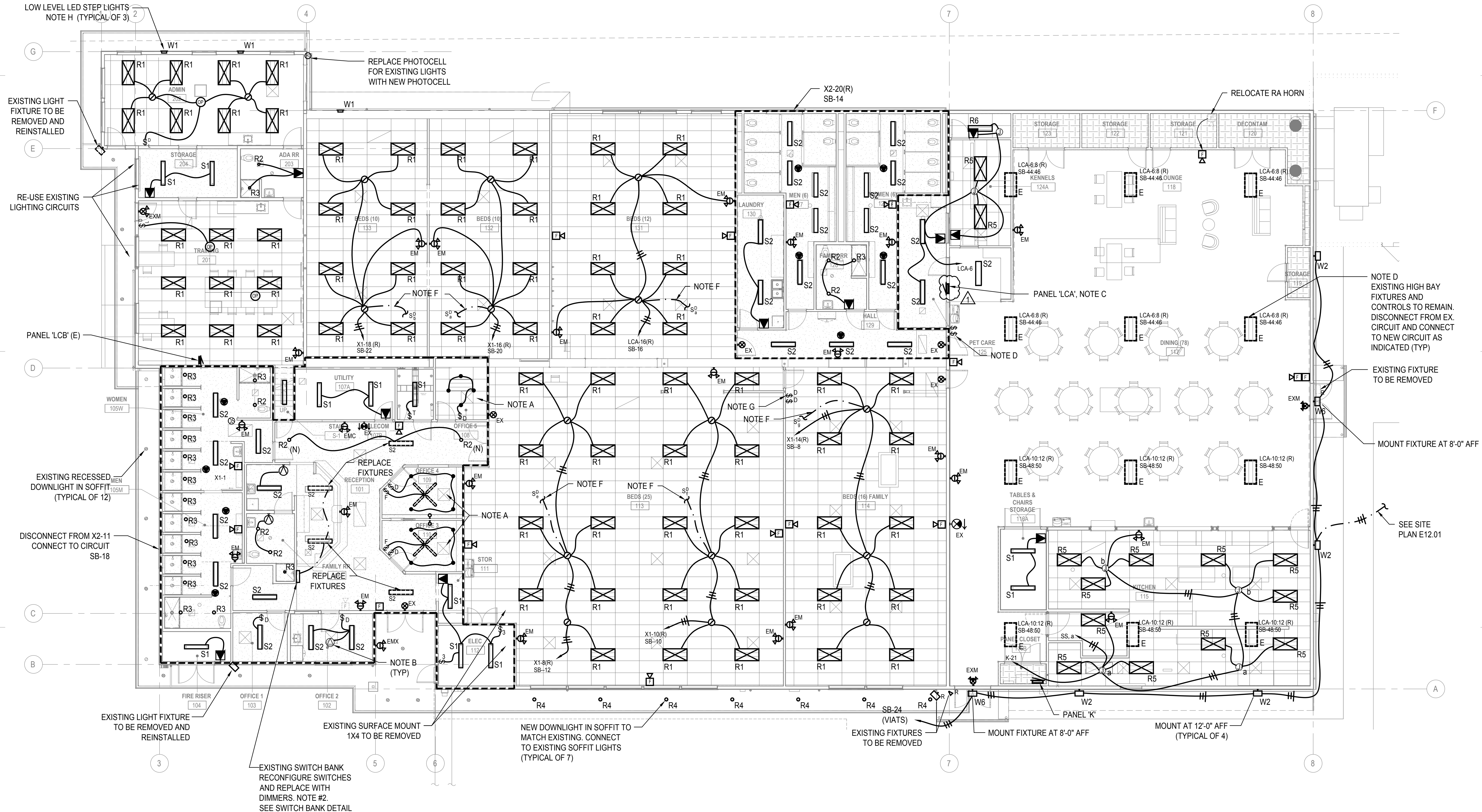

PACIFIC BUILDING CONVERSION
 KITSAP COUNTY HUMAN SERVICES DEPARTMENT
 4459 SE MILE HILL DRIVE
 PORT ORCHARD, WA 98366

PROJECT # 21082

BID SET

ISSUE DATE OCTOBER 23, 2023

REVISION SCHEDULE		
1	ADDENDUM #2	11/29/2023

AHJ APPROVAL STAMP

FLOOR PLAN - LIGHTING
 SCALE: 1/8" = 1'-0"

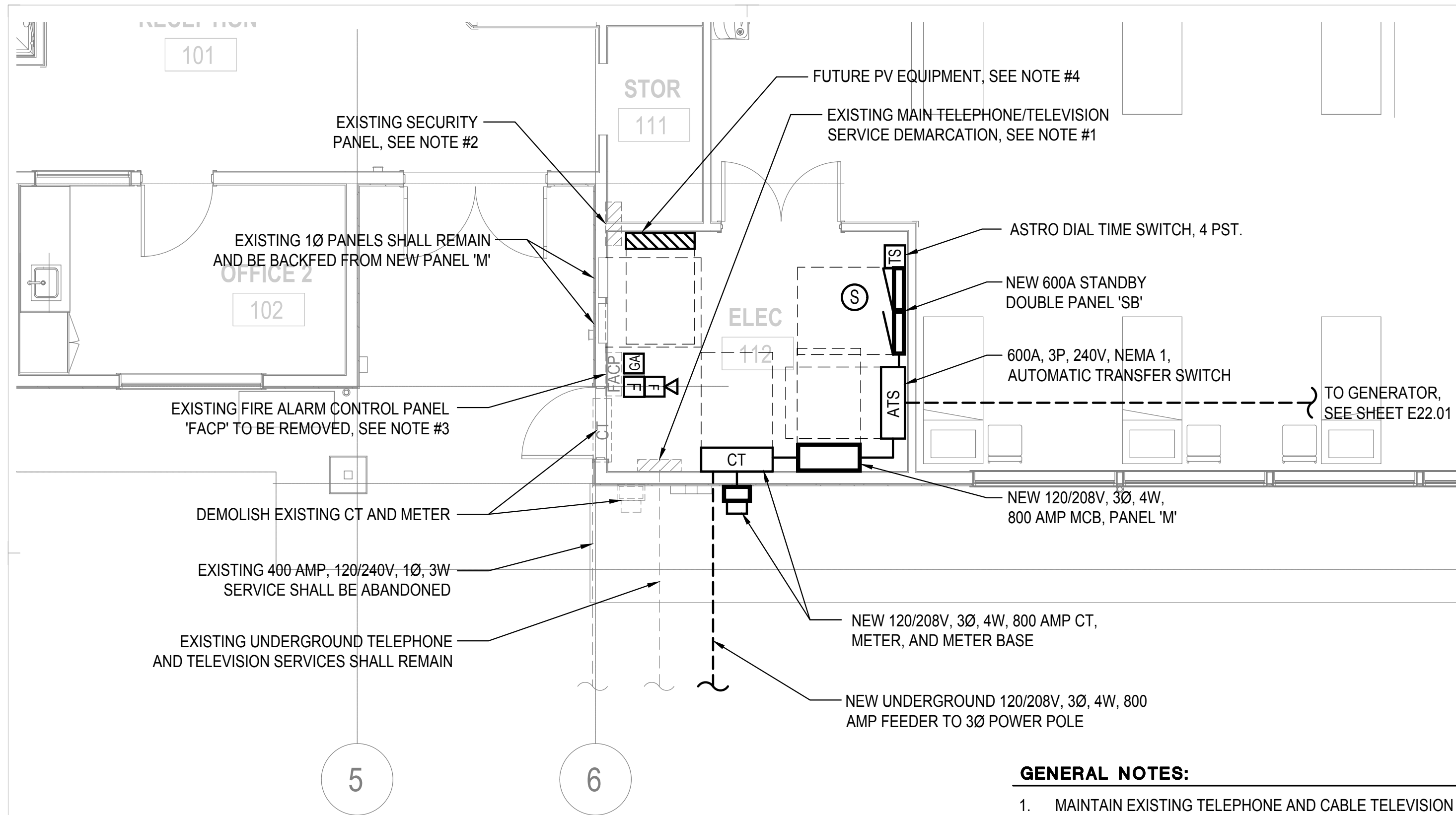

1 ELECTRICAL ROOM
E42.01 1/4"=1'-0"

GENERAL NOTES:

1. MAINTAIN EXISTING TELEPHONE AND CABLE TELEVISION SERVICES. EXTEND 2-2" C.O. TO IT ROOM.
2. DISCONNECT EXISTING SECURITY AND CCTV PANELS. EXTEND WIRING TO IT ROOM AS REQUIRED.
3. FIRE ALARM SYSTEM TO BE REPLACED. PROVIDE FIRE ALARM DEVICES AND CONNECT TO SPRINKLER SYSTEM AS REQUIRED BY CODE. CONNECT TO NEW STANDBY PANEL 'SB'.
4. PROVIDE 1 1/2" CONDUIT ONLY TO ROOF AND CAP FOR FUTURE PV SYSTEM PER WEC.
5. REFER TO DRAWING KS-1 FOR KITCHEN EQUIPMENT PLAN, SCHEDULES AND CONNECTION REQUIREMENT.

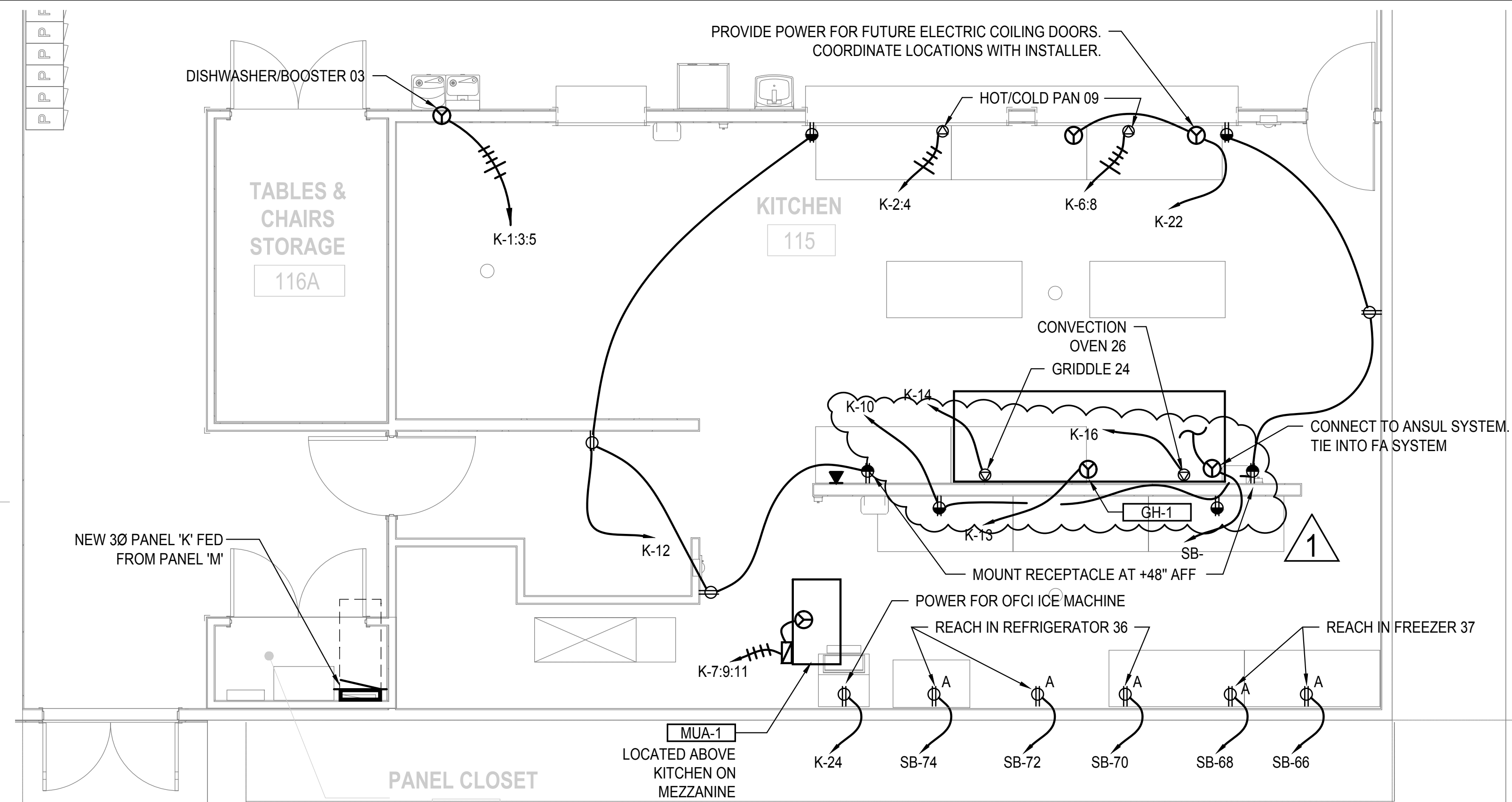

2 COMMERCIAL KITCHEN
E42.01 1/4"=1'-0"

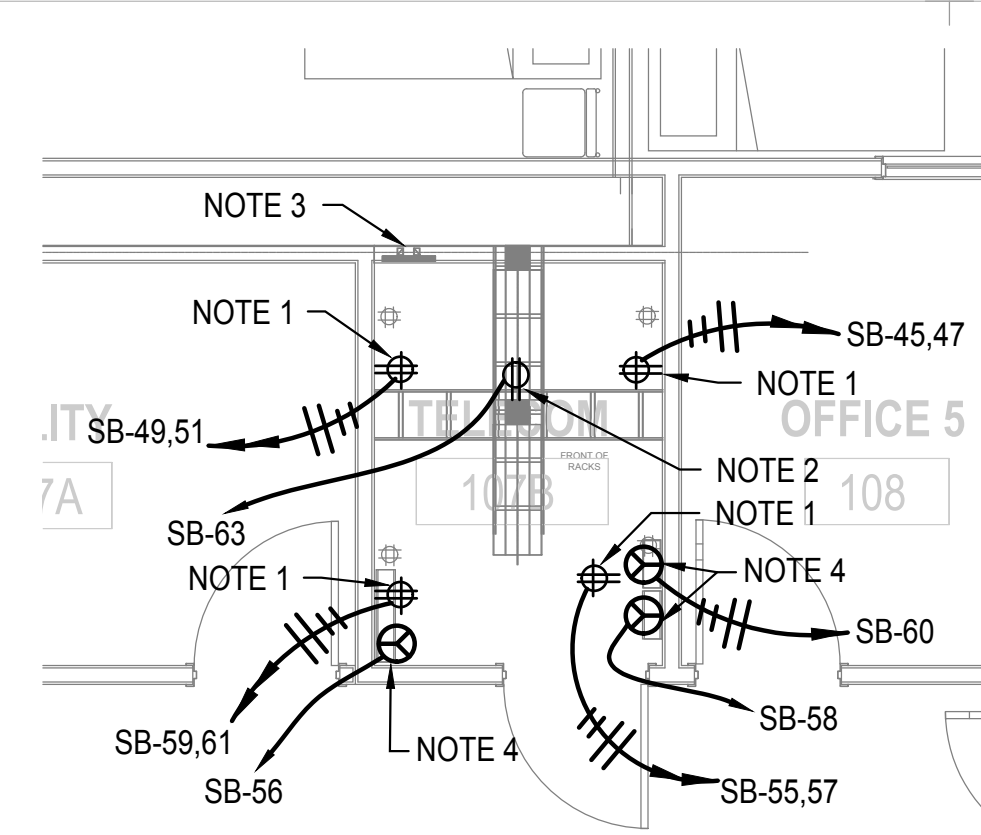

3 TELECOM ROOM - POWER PARTIAL PLAN
E42.01 1/4"=1'-0"

TELECOM ROOM NOTES:

1. INSTALL 2-20 AMP CIRCUITS IN A 4-PLEX OUTLET BOX WITH NEMA 5-20R RECEPTACLES, MOUNT AT 15" A.F.F. COORDINATE EXACT LOCATIONS WITH OWNER.
2. INSTALL 1-20 AMP CIRCUIT WITH NEMA 5-20R RECEPTACLES AT THE TOP OF BACKSIDE OF RACK.
3. GROUND BUSBAR (TGB) TO BE MOUNTED 8" A.F.F. GROUND TO BUILDING GROUND.
4. CONNECT TO FIRE ALARM AND SECURITY PANELS.
5. ALL WALL MOUNTED RECEPTACLES TO BE MOUNTED FLUSH WITH PLYWOOD, 5/8" WITH FIRE RETARDANT PAINT (TYP)
6. COORDINATE LIGHT FIXTURE LOCATIONS WITH IT EQUIPMENT LAYOUT.

SWITCH LEGEND

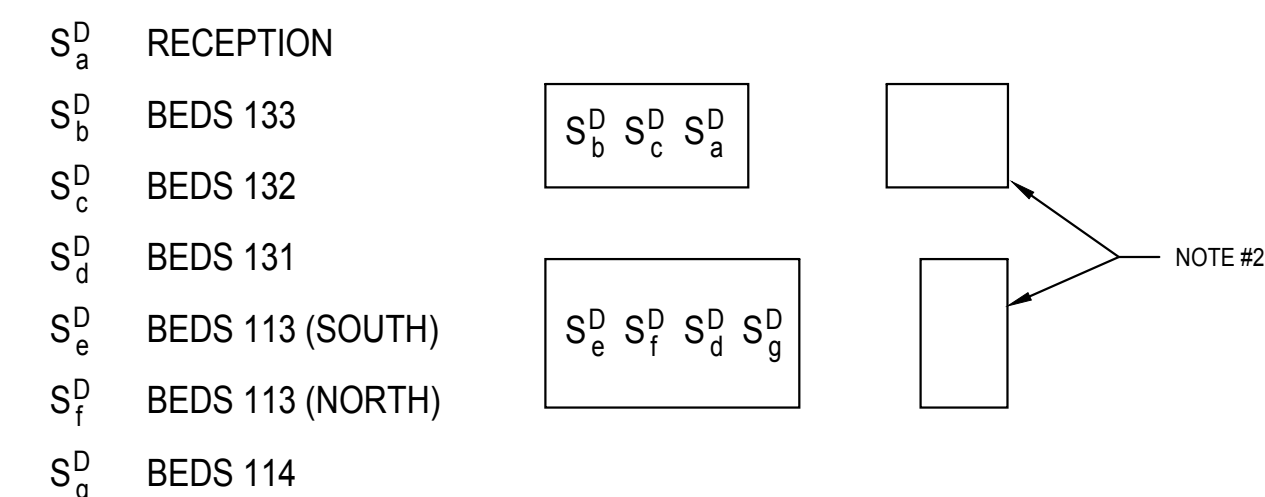

NOTES:

1. SWITCH OUTLET BOXES ARE EXISTING. REMOVE EXISTING SWITCHES AND REPLACE SWITCHES AND WIRING AS INDICATED.
2. BLANK-OFF OR REMOVE UN-USED OUTLET BOXES.

4 SWITCH BANK DETAIL
E42.01 N.T.S.

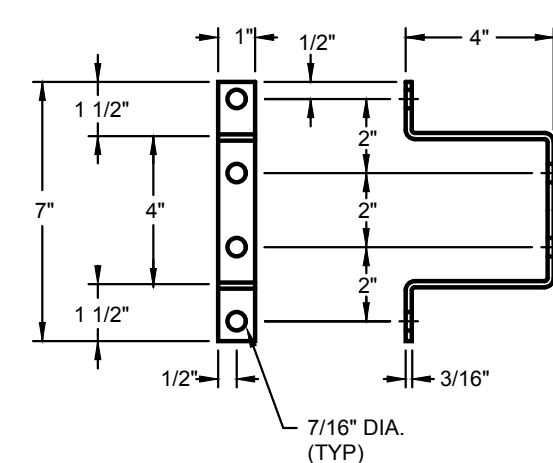

BRACKET DETAIL
NTS

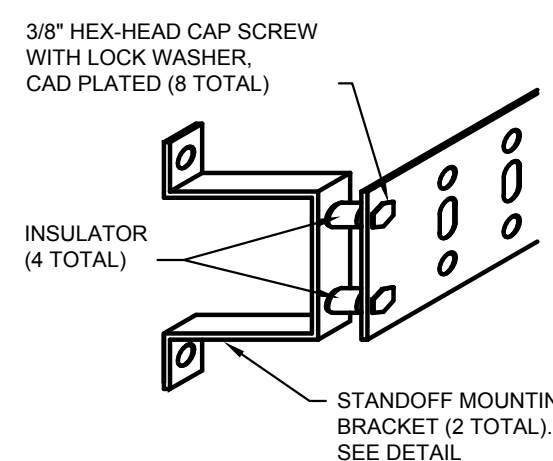

ISOMETRIC VIEW
NTS

NOTES:

1. SURFACE OF GROUND BARS SHALL BE FREE OF BURS & DEFECTS.
2. PROVIDE ALL LUGS WITH APPROPRIATE MOUNTING HARDWARE (BOLTS, NUTS, LOCK WASHERS), CAD PLATED.
3. GROUND BAR IS AVAILABLE FROM: EVERETT SOUND MACHINE WORKS, INC. 2802 NORTON EVERETT, WA 98206 (425) 259-2216

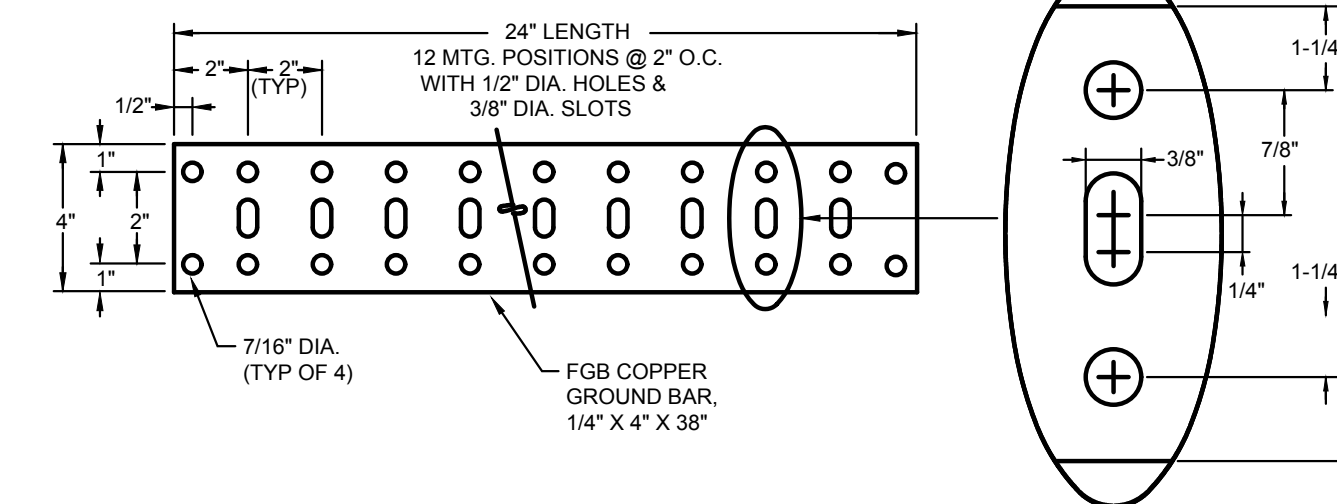

5 GROUND BAR MOUNTING DETAILS
E42.01 N.T.S.

PROJECT # 21082

BID SET

ISSUE DATE OCTOBER 23, 2023

REVISION SCHEDULE		
NO.	ADDENDUM #2	DATE
1		11/29/2023

AHJ APPROVAL STAMP

ENLARGED DETAILS

EMERICK

Residential Builders

Chad Hanson
VP of Operations

chanson@emerickbuilders.com
m 503.201.3937



RYAN POPPE
PROJECT MANAGER

ryan@chinookcontractors.com
10661 Old Frontier Road NW, Suite 231
Silverdale, WA 98383-8897
main 360.613.4098 | cell 360.551.7422

WWW.CHINOOKCONTRACTORS.COM

CLINTON OLSEN
ESTIMATOR | PROJECT MANAGER

clinton@chinookcontractors.com
10661 Old Frontier Road NW, Suite 231
Silverdale, WA 98383-8897
main 360.613.4098 | cell 360.865.8014
WWW.CHINOOKCONTRACTORS.COM

Sound Excavation, Inc.
Residential * Commercial
Bonded



Rhonda Hoskins
CONTROLLER

5902 W. Sherman Heights Rd., Bremerton, WA 98312
360-373-1613 • Fax 360-792-5964
rhonda@soundexcavation.com

Aaron Gallington
Chief Estimator
Rush Commercial Construction

✉ agallington@therushcompanies.com
☎ D. (253) 432.7157
☎ C. (360) 628.3801

The Rush Companies
6622 Wollochet Dr, Gig Harbor, WA 98335
www.therushcompanies.com

R
RUSH

ZIVA ENTERPRISES INC

Austin Taylor

Superintendent



Expect Moore!
MOORE
CONSTRUCTION

Matt Moore
Owner & Operator

360.265.6904
expectmooreconst.com



Expect Moore!
MOORE
CONSTRUCTION

Kevin Cummins
Director of Operations

Cell: 360-535-0609
Office: 360-265-6904
kcumminsmooreconst@gmail.com
expectmooreconst.com
LLC #604762985



Expect Moore!
MOORE
ELECTRICAL SERVICES

360-265-6904
expectmooreconst@gmail.com
expectmooreconst.com
LIC# MOORECL771CM



Eagle Harbor Associates, LLC
Mechanical Contractor

Cell: (360) 867-8009
Office: (360) 779-8201

8965 Select Ct. SE
Tumwater, WA 98501

Jeff Olson
Sr. Project Manager

jeffo@eagleharbor.build

RAY NAKAMURA

RAY@NCSTRUCTURES.COM

(253) 732.3530

WWW.NCSTRUCTURES.COM

Daryl Read

O: 360-895-7747
C: 360-633-0878

Daryl@disneyhomespnw.com
www.disneyhomespnw.com
DISNEY AT 905MI



Eric Solem
Project Director

Cell: 619.770.7216
Office: 206.453.1005
Email: EricS@exxelpacific.com

323 Telegraph Road, Bellingham, WA 98226
4220 Aurora Avenue N, Seattle, WA 98103



CHAD FURSTENWERTH
SENIOR PROJECT SUPERINTENDENT

CELL 206-227-9334

cfurstenwerth@asistructures.com
5601 - 6th Avenue South
Suite 510
Seattle, WA 98108

WWW.ASISTRUCTURES.COM



RESIDENTIAL ♦ COMMERCIAL ♦ INDUSTRIAL

Jeremy Linn
Project Manager
360.710.9647 cell

Licensed, Bonded & Insured
WA Contra # MATHEEC886C8
360.598.1850 office

jeremy@mathewselectric.net
www.mathewselectriccorporation.com



Brady Mueller
Principal/Managing Partner
brady@paintwa.com

360-689-5772 ext. 1
9654 SE Southworth Dr.
Port Orchard, WA 98366

D P Wain Construction, Inc.

360 698-5917

Licensed/Bonded/Insured - General Contractor
DPWAIC1060N6

Fax - 360-698-6797 | PO Box 3771
dpwain@msn.com | Silverdale, WA 98383

Ashley Oaksmith

MARKETING & BUSINESS DEVELOPMENT
MANAGER

O: 206.842.5450 x787
C: 715.216.2691
ashley.oaksmith@clarkconstruct.com

www.clarkconstruct.com



JAMES ATTEBERY
Estimator

Cellular: 253-380-4106
Email: James@peaseinc.com

Main Office: 253-584-6606
Main Office Fax: 253-581-7855

3815-100th Street SW, #3A
Lakewood, WA 98499
www.peaseinc.com

BAYLEY

WADE MEYER
Director of Preconstruction
& Estimating

wadem@bayley.net

P (206) 621-8884
C (206) 510-0047
F (206) 343-7728

8005 S.E. 28th St.
Mercer Island, WA 98040

MADSEN ROOFING

COMMERCIAL ROOFING EST. 1982

Marshall Whisler
VP of Sales

Cell: 253-778-3794
marshall@madsenroofing.com

8625 Martin Way East • Lacey, WA 98516
Office: 360.456.2821 • www.madsenroofing.com
MADSERI147JD

OLYMPIC ROOFING

Cowboy Chris Stritzke cowboy@olympicroofingllc.com
Cell (206) 214-6969 1505 S 356th St., Ste 112
Office (253) 878-5311 Federal Way, WA 98003

OLYMPRL834PQ



DAN DURKIN
SALES@ROCKSTARFLOORS.US
253 376-5043

RON SISEMORE
360.340.0799 CELL



OFFICE 360.377.1400

RON@TALBOTEXCAVATING.COM

P.O. BOX 4791, BREMERTON, WA 98312

Residential, Commercial,
and Federal Installation

Hailey Robison | Owner
P: 360.440.6733

E: hailey@koivuelectric.com

koivuelectric.com

JOSHUA HUNTER DBIA
Project Manager



PCL Construction Services, Inc.

13920 SE Eastgate Way, Suite 400
Bellevue, Washington 98005
PCL.com

Phone (425) 454 8020
Cell (425) 457 3436
jjhunter@pcl.com



Michael McCarley



Dustin Parris

Electrician
michaelm@nexuselectric.co

P. 360-443-6995
1415 Lumsden Rd
Port Orchard, WA 98367

General Manager
office@nexuselectric.co

P. 360-443-6995
C. 360-979-0049
1415 Lumsden Rd
Port Orchard, WA 98367



Jeff Hazlewood, Field Superintendant

219 12th St. SE
Puyallup, WA 98372
jhazlewood@ascdemo.com
www.ascendentdemo.com

Office: (253) 939-4375
Cell: (253) 455-4000
Fax: (253) 939-5720

Christensen Inc.

GENERAL CONTRACTOR

Dave Clark
PROJECT MANAGER

2840 Crites St. SW, Ste. 100
Tumwater, WA 98512
FAX 360-709-0220
CHRISIG066LB

OFFICE 360-709-0330
CELL 360-999-9034
EMAIL dave@cincgc.com
WEB cincgc.com

WESTERN VENTURES
CONSTRUCTION



Thomas (Taus) Casswell
Superintendent

E tcasswell@westernventures.com
C 253/686 1308
O 425/640 5050
F 425/640 8020

P.O. Box 298
Mountlake Terrace
Washington 98043
WESTEVC 179KB

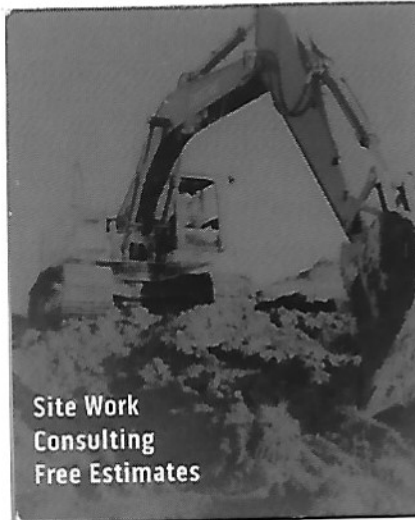

Site Work
Consulting
Free Estimates

PECC

Excellence in Excavation for over 30 years

Randy Ponce

Owner

ponceexcavation@gmail.com

Office--360-297-0773

Cell--541-914-3171

27420 Garden Gate Ave NE
Kingston, WA 98346



BEACON

EXTERIOR
PRODUCTS

Tyler Savage

Outside Sales

M 253-349-0794
Tyler.Savage@becn.com
2015 112th Street South
Tacoma, WA 98444



BJC GROUP
Your Construction Source

Rod McCarten

Senior Project Manager
& Estimator

(360) 895-0896 (360) 280-5486

3780 SE Mile Hill Dr., P.O. Box 2030
Port Orchard, WA 98366

rmccarten@bjcgroup.com

www.bjcgroup.com



Kitsap County
Department of Human Services

1/4

Site Visit - Sign-in Sheet
Monday, November 6, 2023 @ 10 am
2023-049 IFB
Pacific Building Renovation

PLEASE WRITE LEGIBILITY – PLEASE LEAVE BUSINESS CARD

Name	Company	Phone	Email	Card Y/N
1. ^{John} ACKER	Emerick	971-270-5900	Jacker@	✓
2. CLAD HANSON	"	"	CLAD HANSON@	✓
3. Ryan Pepp	Chinook	360 613 4645	Ryan@chinookcontractors.com	✓
4. CLINTON OLSEN	CHIROOK CONTRACTORS	360 865 8014	CLINTON@CHIROOKCONTRACTORS.COM	✓
5. JELEUKHART	Sound ec	360 373 1613	RHONDA@SOUNDESCOUTERS.COM	✓
6. Aaron Gallington	Rush	360-628-3801	agallington@therushcompanies.com	✓
7. Austin Taylor	Ziva Ent.	253-582-2943	Ziva.ataylor@gmail.com	•
8. Matt Moore	Moore Construction LLC	216 213 7524	Expectmooreconst@gmail.com	✓
9. Mike Meigs	Moore Construction LLC	(360) 990-1187	MMeigsMooreconst@gmail	N
10. ^{Charlie} Blankenship	FormaConst	360-754-5788	ESTIMATING@FORMAEC.COM	N
11. Jeff Olson	Eagle Harbor mechan	360 867 8009	jeffo@eagleharbor.build	Y
RAY NAKAMURA	NC STRUCTURES	253 732-3530	Ray@NCSTRUCTURES.COM	
Debbie Howells	Lincoln Construction	253-847-6414	BIDS@LINCOLNHW.COM	N



Kitsap County
Department of Human Services

2/4

Site Visit - Sign-in Sheet
Monday, November 6, 2023 @ 10 am
2023-049 IFB
Pacific Building Renovation

PLEASE WRITE LEGIBILITY – PLEASE LEAVE BUSINESS CARD

Name	Company	Phone	Email	Card Y/N
12 Danyl Renn	DISNEY & ASSOC.	360-633-0878	Danyl@DisneyHomesPnw.com Pnw.com	Yes
13 Eric Solem	Exxel Pacific Inc	619-770-7216	eric@exxelpacific.com	Yes
14 CHAD FURSTENWIRTH	ANDERSON CONSTRUCTION	206-227-9334	cfurstenwirth@ssi-structures.com	Yes
15 Jeremy Linn	Matthews Elec.	360-594-1850	Jeremy@Matthewselectric.net	Yes
16 Brady Mueller	Quality Coating Enterprises	360-689-5172	Brady@paintwa.com	Yes
17 Summer Reeves	JH Kelly	360-523-3906	sreeves@jhkelly.com	No
18 Justin Stoddard	Jimmy's Roofing	(425) 998-3260	J.stoddard@jimmysroofing.com	No
19 Daryl Wain	DP Wain Co	360-698-5917	DPWAIN@MSV.com	
20 Jeff Over	DP Wain		DPWain500@gmail.com	
21				
22				
23				
24				



Kitsap County
Department of Human Services

3/4

Site Visit - Sign-in Sheet
Monday, November 6, 2023 @ 10 am
2023-049 IFB
Pacific Building Renovation

PLEASE WRITE LEGIBILITY – PLEASE LEAVE BUSINESS CARD

Name	Company	Phone	Email	Card Y/N
1. Ashly ORSMILL	Clark Construction	360-710-8424	bids@clarkconstruct.com (Marty)	Y
2. ATTEBERY, JAMES	PEASE CONST.	253-584-6606	estimating@peaseinc.com	Y
BRIAN HOGMAN	NEELEY CONST	253-845-8838	bids@neeleycorp.com	N
4. DAN MULVILL	CDK CONSTRUCTION SERVICES	425-788-2441	BIDS@CDKCONSTRUCTION.COM	N
5. Wade Meyer	Bayley Construction	206-621-8884	Wadem@bayley.net	Y
6. Marshall Whistler	Madsen Roofing	253-778-3794	Marshall@MadsenRoofing.com	Y
7. Jonathan Berdo	Miller Sheetmetal	360-479-1727	jonathan@millersheetmetal.com	N
8. Chris Strutzke	Olympic Roofing	206-214-6969	Cowboy@OlympicRoofingLLC.com	Yes
9. Dan Durkin	Rockstar Floors	253-376-5043	sales@rockstarfloors.us	Yes
10. Kyle Desith	Talbot EXC	360-340-5952	Aerith@Talbotexcavating.com	Yes
11. Michelle Willeg	Northwest Fencing	253-313-5299	michelle@scencnw.com	



Kitsap County
Department of Human Services

4/4

Site Visit - Sign-in Sheet
Monday, November 6, 2023 @ 10 am
2023-049 IFB
Pacific Building Renovation

PLEASE WRITE LEGIBILITY – PLEASE LEAVE BUSINESS CARD

Name	Company	Phone	Email	Card Y/N
12 Hailey Robison	Koivu Electric	360.440.6733	hailey@koivuelectric.com	yes
13 Kevin Cummins	MOORE CONSTRUCTION	360-535-0609	Kcumminsmooreconst@gmail.com	YES
14 JOSH HUNTER	PCL CONSTRUCTION SEA	425-457-3436	jhunter@pcl.com	yes
15 Bryan Guo-Antik	Bratonia Mech	360-949-3237	Bryan@bratoniamech.com	N
16 Kurt Moyer	Pacific Tech Const.	360-414-8284	estimating@pactechgroup.com	N
17 Michael McClure	Nexus Electric	360-443-6995	michaelm@NexisElectric.co	Y
18 JEFF HAZLEWOOD	ASCENDANT Demos	253-455-4000	jhaazlewood@ascdemo.com	N
19 Dave CLARK	Christensen Inc. General Cont.	360-999-9034	Bids@cinjce.com	N
20 Travis Casswell	Western Ventures	425-646-5050	Info@westernventures.com	N
21 Randal Ponce	PECC	541-914-3171	poncellexcavation@gmail.com	Y
22 TYLER SAVAGE	BEACON	253-349-0794	Tyler.savage@BEACON.com	Y
23 Roy McCARTON	BTC GROUP	360-280-5486	RMCCARTON@BTCGROUP.COM	Y
24 Ron Sisemore	TALBOT EXCAVATING	360-377-1400	ron@talbotexcavating.com	Y